

DORMER  **PRAMET**

**PERÇAGE
ET ALÉSAGE**

2021 – 2022

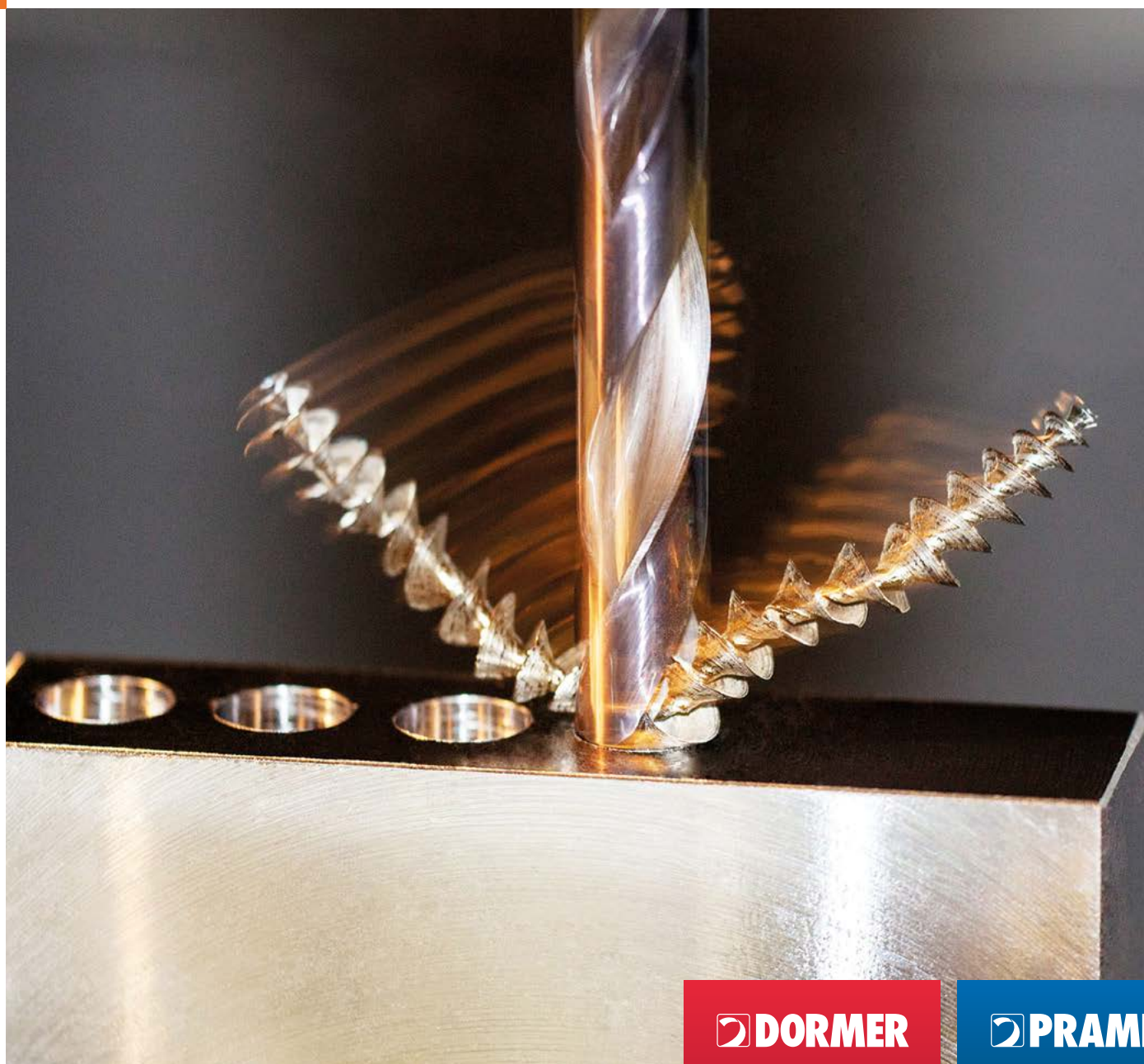

 **DORMER**

 **PRAMET**



PERÇAGE ET ALÉSAGE – CONTENU GÉNÉRAL

6		WMG ET ISO 13399
12	FORETS MONOBLOCS	INSTRUCTIONS
15		FORETS CARBURE
66		FORETS HSS
176		INFORMATIONS TECHNIQUES
186		FLUIDES DE COUPE
190		ALÉSOIRS ET FRAISES À CHANFREINER
264	FORETS INDEXABLES	INSTRUCTIONS
271		FORETS HYDRA À TÊTE INTERCHANGEABLE
297		INFORMATIONS TECHNIQUES
307		FORETS À PLAQUETTES INDEXABLES
327		INFORMATIONS TECHNIQUES
350	SYSTÈMES D'ALÉSAGE	INSTRUCTIONS
359		TÊTES À ALÉSER
376		ACCESSOIRES D'ALÉSAGE
381		PLAQUETTES
404		ATTACHEMENTS
418		KITS D'ALÉSAGE
429		INFORMATIONS TECHNIQUES



FAMILLE		FAMILLE		FAMILLE		FAMILLE	
A		A243	120	B180	216	H	
A002	96	A244	121	B301	211	H851	287
A002S	98	A266	158	B334	208	H8512	294
A022	82	A295	172	B335	209	H853	289
A080	169	A296	173	B400	200	H855	291
A087	166	A345	146	B411	204	H858	293
A088	165	A350	144	B441	203	H860	295
A089	167	A400	150	B442	205	H861	296
A094	166	A402	151	B481	201	M	
A095	165	A405	152	B901	210	M150	173
A099	168	A412	153	B903	212	M151	174
A100	99	A413	154	B952	213	M152	174
A101	103	A510	111	B953	215	M200-1	187
A108	104	A520	88	B954	225	M200-2	187
A110	122	A530	140	B955	226	M200-3	188
A117	86	A553	113	B956	227	R	
A119	77	A620	84	B957	228	R100	34
A120	80	A720	91	G		R120	32
A122	78	A723	76	G106	238	R122	27
A123	79	A730	141	G107	242	R123	28
A124	90	A777	108	G125	249	R125	29
A125	128	A900	114	G129	234	R200	26
A130	134	A901	116	G132	244	R453	52
A147	106	A920	92	G135	230	R454	48
A160	110	A921	94	G136	236	R457	44
A166	143	A940	124	G137	232	R458	40
A170	118	A941	126	G138	245	R459	56
A188	172	A951	148	G142	240	R463	62
A190	170	A952	149	G149	235	R467	59
A191	171	A976	130	G154	233	R510	38
A199	169	A977	132	G171	247	R520	36
A200	155	A978	133	G236	250	R6011	30
A201	160	B		G314	248	R7131	31
A205	156	B100	206	G335	231	R950	281
A206	157	B101	222	G338	246	R960	283
A210	159	B121	224	G400	229	R970	285
A225	161	B122	214	G506	239		
A237	162	B157	220	G560	237		
A238	163	B161	221	G570	241		
A242	164	B170	218	G600	243		



FAMILLE		FAMILLE		FAMILLE		FAMILLE	
Z		BS 54 KIT TC 8-210	427	EXT-BS	415	M	
2080-BS	411	BT-BS	408	F		MB-H	373
69871-BS	406	C		F75	367	MOR-BS	413
802D	313	CART-BS-SPC	378	F75-BB	369	R	
803D	315	CART-BS-STD	379	F75-C	368	RED-BS	416
804D	318	CHAM-BS	380	F90	370	W	
805D	320	D		F90-BB	372	WEL-BS	414
B		D75	361	F90-C	371		
BS 54 KIT RC 8-043	420	D75-BB	363	H			
BS 54 KIT RC 8-100	421	D75-C	362	HSK-BS	410		
BS 54 KIT RC 8-170	422	D90	364	I			
BS 54 KIT RC 8-210	423	D90-BB	366	ISO BARS	374		
BS 54 KIT TC 8-043	424	D90-C	365	ISO BARS A042	375		
BS 54 KIT TC 8-100	425	E		L			
BS 54 KIT TC 8-170	426	EP	322	LA-BS	417		

FAMILLE		FAMILLE	
C		S	
CCGT	388	SCET	323
CCGW CBN	390	T	
CCMT	390	TCGT	401
CCMW	393	TCMT	402
CNGA CBN	394	TCMW	403
CNGG	395	W	
CNMA	395	WCMT-ID	325
CNMG	396	WCMX	326
D		X	
DCMT	398	XPET	324
DCMW	399		
DCMW PCD	399		
E			
EPGX	400		
EPMT	400		



DORMER PRAMET



ÉCONOMISEUR DE POCHE

Notre calculateur d'usinage vous permet de mesurer les économies réalisées en fonction des différents produits et applications. Un outil de poche utile qui vous aidera à garder l'argent dans vos poches! **Simply Reliable.**

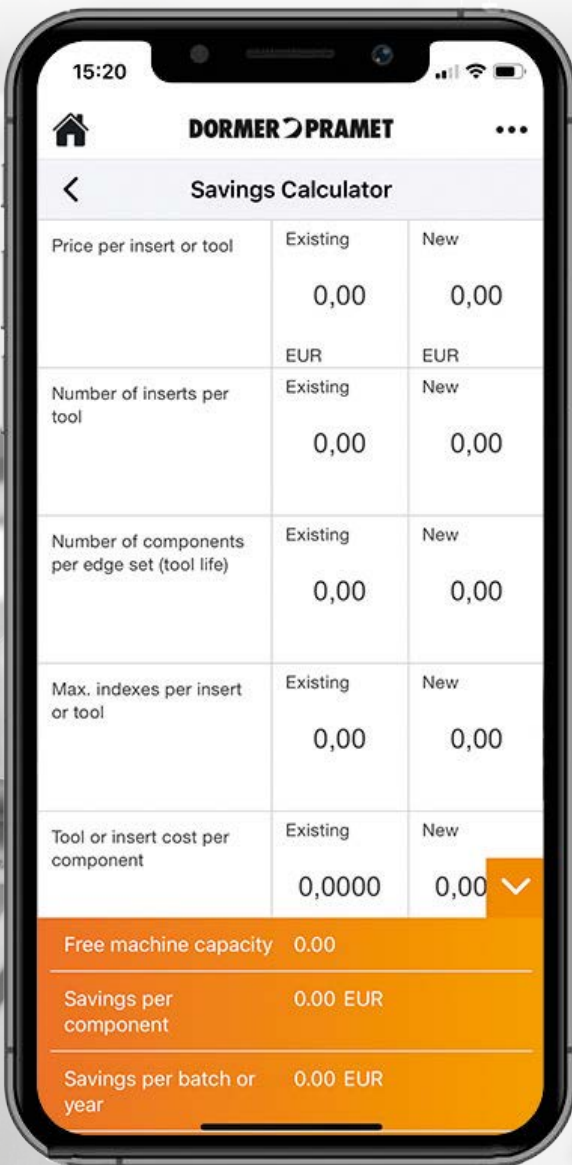



PERÇAGE ET ALÉSAGE – CONTENU GÉNÉRAL

6		WMG ET ISO 13399
12	FORETS MONOBLOCS	INSTRUCTIONS
15		FORETS CARBURE
66		FORETS HSS
176		INFORMATIONS TECHNIQUES
186		FLUIDES DE COUPE
190		ALÉSOIRS ET FRAISES À CHANFREINER
264	FORETS INDEXABLES	INSTRUCTIONS
271		FORETS HYDRA À TÊTE INTERCHANGEABLE
297		INFORMATIONS TECHNIQUES
307		FORETS À PLAQUETTES INDEXABLES
327		INFORMATIONS TECHNIQUES
350	SYSTÈMES D'ALÉSAGE	INSTRUCTIONS
359		TÊTES À ALÉSER
376		ACCESSOIRES D'ALÉSAGE
381		PLAQUETTES
404		ATTACHEMENTS
418		KITS D'ALÉSAGE
429		INFORMATIONS TECHNIQUES



GROUPES DE MATÉRIAUX À USINER (WMG)

ISO Pour sélectionner une nuance et une géométrie convenant à une large gamme de matériaux à usiner

Définition générale
acier, acier inoxydable, etc.

P **M** **K** **N** **S** **H**

Sous-groupe Pour parcourir et choisir un outil adapté à une gamme plus spécifique de matériaux à usiner

Définition en fonction de la structure/composition
acier simple au carbone, acier spécial, etc.

P **M** **K** **N** **S** **H**

P1

P2

P3

P4

WMG Pour choisir et respecter des conditions de coupe données avec une marge de $\pm 10\%$

Définition en fonction de la dureté/résistance à la traction max.
160 < 220 HB, 620 < 900 n/mm²; etc.

P

P1 **P1.1** **P1.2** **P1.3**

P2 **P2.1** **P2.2** **P2.3**

P3 **P3.1** **P3.2** **P3.3**

P4 **P4.1** **P4.2** **P4.3**

À PROPOS DE LA CLASSIFICATION DES MATÉRIAUX À USINER DE DORMER PRAMET

Les groupes de matériaux à usiner (WMG pour Workpiece Material Groups) permettent de choisir plus facilement et en toute assurance le bon outil de coupe avec les valeurs de départ adaptées aux conditions d'un usinage particulier.

Dormer Pramet classe les matériaux à usiner en six groupes de couleurs différentes :

- **Bleu**: aciers et aciers moulés (groupe P)
- **Jaune**: aciers inoxydables (groupe M)
- **Rouge**: fontes (groupe K)
- **Vert**: métaux non ferreux (groupe N)
- **Brun** : alliages haute température (groupe S)
- **Gris**: matériaux durs (groupe H)

Chacun de ces groupes se divise en sous-groupes en fonction de la structure et/ou de la composition des matériaux. Par exemple, les aciers et aciers moulés du groupe P sont classés en quatre sous-groupes, comme suit :

- **P1: acier de décolletage**
- **P2: acier simple au carbone**
- **P3: acier allié**
- **P4: acier à outil**

Un dernier classement se fait en fonction des propriétés du matériau, comme sa dureté et sa résistance à la traction maximale. Nos clients peuvent ainsi choisir l'outil le mieux adapté à leur application et ils disposent des valeurs de vitesse de coupe et d'avance initiales.

Le tableau de la page suivante comprend une description de chaque groupe de matériaux à usiner ainsi que des exemples, avec des désignations courantes.



GROUPES DE MATÉRIAUX À USINER (WMG)

Groupe ISO	Groupes de matériaux à usiner (WMG)		Dureté (HB ou HRC)	Résistance à la traction max. (MPa)		
P	P1	P1.1	Manganèse	< 240 HB	≤ 830	
		P1.2	Acier de décolletage	Manganèse et phosphore	< 180 HB	≤ 620
		P1.3	(aciers au carbone, usinabilité accrue)	Manganèse/phosphore et plomb	< 180 HB	≤ 620
	P2	P2.1	Acier simple au carbone (aciers principalement composés de fer et de carbone)	Teneur en carbone <0,25 %c	< 180 HB	≤ 620
		P2.2		Teneur en carbone <0,55 %c	< 240 HB	≤ 830
		P2.3		Teneur en carbone <0,55 %c	< 300 HB	≤ 1030
	P3	P3.1	Acier allié (aciers au carbone avec une teneur en alliage ≤ 10 %)	Recuit	< 180 HB	≤ 620
		P3.2		Durci et trempé	180 – 260 HB	> 620 ≤ 900
		P3.3			260 – 360 HB	> 900 ≤ 1240
	P4	P4.1	Acier à outil (acier allié spécial pour outils, moules et matrices)	Recuit	< 26 HRC	≤ 900
P4.2		Durci et trempé		26 – 39 HRC	> 900 ≤ 1240	
P4.3				39 – 45 HRC	> 1240 ≤ 1450	
M	M1	M1.1	Acier inoxydable ferritique (alliages non durcissables au chrome droit)	< 160 HB	≤ 520	
		M1.2		160 – 220 HB	> 520 ≤ 700	
	M2	M2.1	Acier inoxydable martensitique (alliages durcissables au chrome droit)	Recuit	< 200 HB	≤ 670
		M2.2		Revenu et trempé	200 – 280 HB	> 670 ≤ 950
		M2.3		Durci par précipitation	280 – 380 HB	> 950 ≤ 1300
	M3	M3.1	Acier inoxydable austénitique (alliages chrome-nickel et chrome-nickel-manganèse)	< 200 HB	≤ 750	
		M3.2		200 – 260 HB	> 750 ≤ 870	
		M3.3		260 – 300 HB	> 870 ≤ 1040	
	M4	M4.1	Acier inoxydable super-austénitique et austéno-ferritique (duplex)	< 300 HB	≤ 990	
		M4.2		Acier inoxydable austénitique à durcissement par précipitation	300 – 380 HB	≤ 1320
K	K1	K1.1	Fonte grise (ASTM A48) ou fonte grise pour l'automobile (ASTM A159) (pièces moulées en fer-carbone avec micro-structure graphite lamellaire)	Ferritique ou ferritique-perlitique	< 180 HB	≤ 190
		K1.2		Ferritique-perlitique ou perlitique	180 – 240 HB	> 190 ≤ 310
		K1.3		Perlitique	240 – 280 HB	> 310 ≤ 390
	K2	K2.1	Fonte malléable (ASTM A602) (pièces moulées en fer-carbone avec micro-structure sans graphite)	Ferritique	< 160 HB	≤ 400
		K2.2		Ferritique ou perlitique	160 – 200 HB	> 400 ≤ 550
		K2.3		Perlitique	200 – 240 HB	> 550 ≤ 660
	K3	K3.1	Fonte malléable (ASTM A536) (pièces moulées en fer-carbone avec micro-structure en graphite nodulaire)	Ferritique	< 180 HB	≤ 560
		K3.2		Ferritique ou perlitique	180 – 220 HB	> 560 ≤ 680
		K3.3		Perlitique	220 – 260 HB	> 680 ≤ 800
	K4	K4.1	Fonte grise austénitique (ASTM A436) (pièces moulées en alliage fer-carbone avec micro-structure graphite lamellaire austénitique)	< 180 HB	≤ 190	
		K4.2		Fonte malléable austénitique (ASTM A439 ou ASTM A571) (alliage fer-carbone avec micro-structure graphite nodulaire austénitique)	< 240 HB	≤ 740
		K4.3			< 280 HB	> 840 ≤ 980
		K4.4			280 – 320 HB	> 980 ≤ 1130
		K4.5		320 – 360 HB	> 1130 ≤ 1280	
	K5	K5.1	Fonte à graphite vermiculaire compactée (ASTM A842) (pièces moulées en fer-carbone avec structure graphite vermiculaire)	Ferritique	< 180 HB	≤ 400
K5.2		Ferritique-perlitique		180 – 220 HB	> 400 ≤ 450	
K5.3		Perlitique		220 – 260 HB	> 450 ≤ 500	
N	N1	N1.1	Aluminium pur corroyé	< 60 HB	≤ 240	
		N1.2		Semi-trempé	60 – 100 HB	> 240 ≤ 400
		N1.3		Trempé	100 – 150 HB	> 400 ≤ 590
	N2	N2.1	Alliages d'aluminium moulé	< 75 HB	≤ 240	
		N2.2		75 – 90 HB	> 240 ≤ 270	
		N2.3		90 – 140 HB	> 270 ≤ 440	
	N3	N3.1	Alliages de cuivre de décolletage avec d'excellentes propriétés d'usinage	–	–	
		N3.2		Alliages de cuivre à copeaux courts avec des propriétés d'usinage bonnes à moyennes	–	–
		N3.3			Alliages de cuivre à longs copeaux et cuivre électrolytique avec des propriétés d'usinage médiocres à moyennes	–
	N4	N4.1	Polymères et thermoplastiques	–	–	
		N4.2		Polymères thermodurcissables	–	–
		N4.3			Polymères renforcés ou composites	–
	N5	N5.1	Graphite	–	–	
	S	S1	S1.1	Titane ou alliages de titane	< 200 HB	≤ 660
			S1.2		200 – 280 HB	> 660 ≤ 950
S1.3			280 – 360 HB		> 950 ≤ 1200	
S2		S2.1	Alliages à base de fer haute température	< 200 HB	≤ 690	
		S2.2		200 – 280 HB	> 690 ≤ 970	
S3		S3.1	Alliages à base de nickel haute température	< 280 HB	≤ 940	
		S3.2		280 – 360 HB	> 940 ≤ 1200	
S4		S4.1	Alliages à base de cuivre haute température	< 240 HB	≤ 800	
		S4.2		240 – 320 HB	> 800 ≤ 1070	
H		H1	H1.1	Fonte en coquille	< 440 HB	–
	H1.2		< 55 HRC		–	
	H2	H2.1	Fonte trempée	> 55 HRC	–	
		H2.2		< 51 HRC	–	
	H3	H3.1	Acier trempé < 55 HRC	51 – 55 HRC	–	
		H3.2		< 55 HRC	–	
H4	H4.1	Acier trempé > 55 HRC	55 – 59 HRC	–		
	H4.2		> 59 HRC	–		



PARAMÈTRES DES OUTILS DE COUPE SELON ISO 13399

Tous les outils de coupe sont définis par un certain nombre de paramètres selon la norme ISO 13399. Cette liste contient tous les paramètres utilisés dans ce catalogue et leurs définitions.

ISO 13399 est une norme internationale d'information sur les outils de coupe. Elle fournit des dimensions et des paramètres dans un format neutre, indépendant de tout système ou nomenclature d'entreprise. Lorsque les outils de coupe sont clairement définis selon une norme globale, tous les types de logiciels peuvent traiter les données électroniques plus rapidement, améliorant la qualité de la communication et contribuant au bon déroulement des échanges d'informations. En

prenant en charge un langage commun dans nos descriptions d'outils de coupe, ce système aidera à la communication du système. Cela vous fera gagner un temps considérable, en facilitant la collecte de données de haute qualité à travers nos 40 000 outils monoblocs et indexables. En utilisant un système conforme ISO 13399, il ne sera pas nécessaire d'interpréter manuellement les données et de les saisir au clavier dans votre système.

Exemples

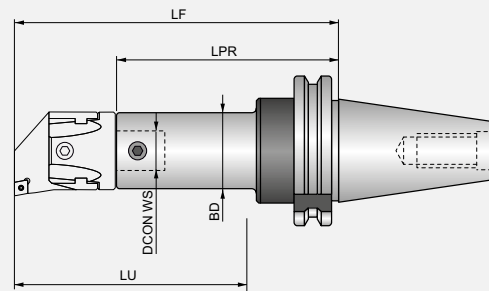
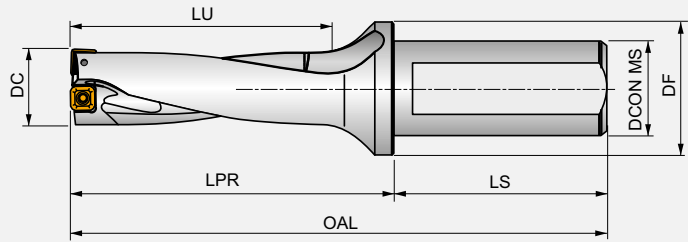
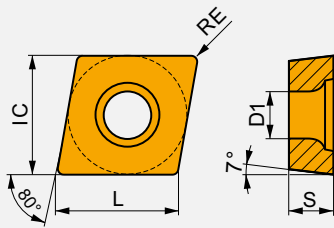
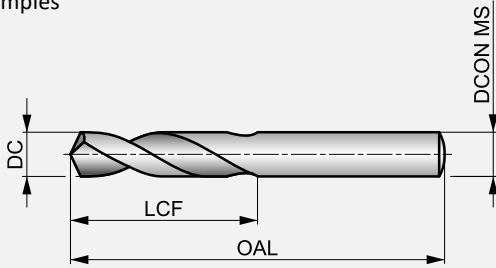

ISO 13399	description
BD	Diamètre du corps
BDX	Diamètre maximum du corps
CZC MS	Code de taille du raccord côté machine
D1	Diamètre du trou de fixation
DC	Diamètre de coupe
DCN	Diamètre de coupe minimum
DCON MS	Diamètre de raccordement côté machine
DCON WS	Diamètre de raccordement côté pièce usinée
DCX	Diamètre de coupe maximum
DHUB	Diamètre de moyeu
FLGT	Épaisseur de bride
IC	Diamètre du cercle inscrit
L	Longueur de l'arête de coupe
LB	Longueur de corps
LF	Longueur fonctionnelle
LPR	Longueur en saillie
LU	Longueur utile
OAL	Longueur totale
RE	Rayon d'angle
S	Épaisseur de plaquette
WF	Largeur fonctionnelle
APMX	Profondeur de coupe maximum
D1	Diamètre du trou de fixation
DC_1	Diamètre de coupe, premier étage
DC_2	Diamètre de coupe, deuxième étage

ISO 13399	description
DF	Diamètre de collerette
DH	Diamètre de la tête
GPD	Diamètre du pilote
GPL	Longueur du pilote
H	Hauteur de queue/de manche
HSD	Taille de l'empreinte
IC	Diamètre du cercle inscrit
LCF	Longueur des goujures
LCOL	Longueur de la pince
LDC	Distance au point de référence PK
LH	Longueur de la tête
LS	Longueur de queue
LSC	Longueur de serrage
NOF	Nombre de goujures
PLGL	Longueur de pointe
RCSK	Rayon de la pointe à centrer
RE	Rayon d'angle
SDI	Incréments, diamètre étagé
SDL	Longueur diamètre étagé
SDL_1	Longueur diamètre étagé 1
SDL_2	Longueur diamètre étagé 2
TDZ	Taille de diamètre du filet
THLGTH	Longueur du filet
WSC	Largeur de serrage



DORMER PRAMET



VOTRE BIBLIOTHÈQUE PERSONNELLE

Vous revenez toujours aux mêmes pages de nos publications ? Notre bibliothèque numérique vous permet d'enregistrer des pages afin que vous puissiez y revenir encore et encore, chaque fois que vous en avez besoin. **Simply Reliable.**

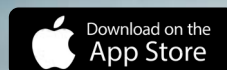



FORETS CARBURE
FORETS HSS





PERÇAGE ET ALÉSAGE – CONTENU GÉNÉRAL

6		WMG ET ISO 13399
12	FORETS MONOBLOCS	INSTRUCTIONS
15		FORETS CARBURE
66		FORETS HSS
176		INFORMATIONS TECHNIQUES
186		FLUIDES DE COUPE
190		
264	FORETS INDEXABLES	INSTRUCTIONS
271		FORETS HYDRA À TÊTE INTERCHANGEABLE
295		INFORMATIONS TECHNIQUES
307		FORETS À PLAQUETTES INDEXABLES
327		INFORMATIONS TECHNIQUES
350	SYSTÈMES D'ALÉSAGE	INSTRUCTIONS
359		TÊTES À ALÉSER
376		ACCESSOIRES D'ALÉSAGE
381		PLAQUETTES
404		ATTACHEMENTS
418		KITS D'ALÉSAGE
429		INFORMATIONS TECHNIQUES



FORETS MONOBLOCS – PAGE DE PRÉSENTATION

1

R100

DORMER



3

Foret carbure monobloc type N longueur 4xD, finition brillante

Foret avec résistance à l'usure améliorée pour une productivité accrue et une durée de vie d'outil prolongée. Une pointe à 120° à 4 facettes aide à l'auto-centrage et réduit les forces de coupe. Peut être utilisé sur tous types de machines CNC.

2

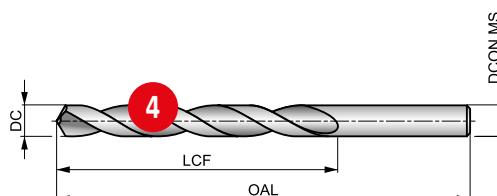

HM	DIN 338	4xD
120°	Bright	
20-35°	R	DC h7

5

Adéquation du groupe de matériaux de la pièce, valeurs de départ pour la vitesse de coupe (m/min) et code Alpha d'avance. Les tableaux d'avances par tour se trouvent à partir de la page 65.

P1.1	P1.2	P1.3	P2.1	P2.2	P2.3	P3.1	P3.2	P3.3	P4.1	P4.2	P4.3	K1.1	K1.2
99 S	111 S	115 S	85 S	75 S	66 S	66 S	53 S	45 S	40 S	34 S	27 S	75 T	56 T
K1.3	K2.1	K2.2	K2.3	K3.1	K3.2	K3.3	K4.1	K4.2	K4.3	K4.4	K4.5	K5.1	K5.2
42 T	68 T	55 T	44 T	60 T	46 T	37	55 T	42 T	31 T	26 T	22 T	63 T	47 T
K5.3	N1.1	N1.2	N1.3	N2.1	N2.2	N2.3	N3.1	N3.2	N4.1	N4.2	H1.1	H2.1	H2.2
37 T	200 V	150 V	100 V	172 V	155 V	112 V	423 V	250 V	60 X	100 V	56 S	33 S	36 S
H3.1	H3.2												
37 S	30 S												

6

Product	DC [mm]	DC [inch]	LCF [mm]	OAL [mm]	DCON MS [mm]
R1001.0	1.00	0.0394	12.0	34.0	1.00
R1001.1	1.10	0.0433	14.0	36.0	1.10
R1001.2	1.20	0.0472	16.0	38.0	1.20
R1001.3	1.30	0.0512	16.0	38.0	1.30
R1001.4	1.40	0.0551	18.0	40.0	1.40
R1001.5	1.50	0.0591	18.0	40.0	1.50
R1001.6	1.60	0.0630	20.0	43.0	1.60
R1001.7	1.70	0.0669	20.0	43.0	1.70
R1001.8	1.80	0.0709	22.0	46.0	1.80
R1001.9	1.90	0.0748	22.0	46.0	1.90
R1002.0	2.00	0.0787	24.0	49.0	2.00

7

8

Product	DC [mm]	DC [inch]	LCF [mm]	OAL [mm]	DCON MS [mm]
R1003.6	3.60	0.1417	39.0	70.0	3.60
R1003.7	3.70	0.1457	39.0	70.0	3.70
R1003.8	3.80	0.1496	43.0	75.0	3.80
R1003.9	3.90	0.1535	43.0	75.0	3.90
R1004.0	4.00	0.1575	43.0	75.0	4.00
R1004.1	4.10	0.1614	43.0	75.0	4.10
R1004.2	4.20	0.1654	43.0	75.0	4.20
R1004.3	4.30	0.1693	47.0	80.0	4.30
R1004.4	4.40	0.1732	47.0	80.0	4.40
R1004.5	4.50	0.1772	47.0	80.0	4.50
R1004.6	4.60	0.1811	47.0	80.0	4.60

Élém.	Description
1	Désignation du foret
2	Descriptif du produit
3	Illustration
4	Schéma de l'outil

Élém.	Description
5	Caractéristiques du produit
6	Recommandations en fonction du groupe de matériaux, notamment indication de la vitesse et de l'avance
7	Code produit
8	Dimensions du produit



FORETS MONOBLOCS – PRÉSENTATION DES ICÔNES

ICÔNES GÉNÉRALES

	Utilisation principale		Utilisation possible
--	------------------------	--	----------------------

ANGLE DE TRAVAIL

	Foret à centrer, à chanfrein de 60°		Foret à centrer, profil de type R		Avant-trou avec chanfrein à 90° (pour taraudage)
	Pointe à 118°		Foret à pointer 90°/120°		Foret à pointer 150°
	Pointe à 120°		Foret à dépointer 180°		Foret à pointer 90°
	Pointe à 122°		Foret étagé (pour fixations), alésage à 180°		Foret à pointer 120°
	Pointe à 130°		Foret étagé (pour fixations), alésage à 90°		
	Pointe à 135°		Pointe à 140°		

NORME (BSG)

	BS 328 – Normes pour forets et alésoirs		DIN 1899 – Micro-forets extra-courts		DIN 8037 – Forets extra-courts à pointe carbure
	DIN 1869 / 1 – Forets extra-longs à queue droite		DIN 333A – Forets à centrer		DIN 8374 – Forets étagés 90°
	DIN 1869 / 2 – Forets extra-longs à queue droite		DIN 333R – Forets à centrer, queue droite		DIN 8376 – Forets étagés 180°
	DIN 1869 / 3 – Forets extra-longs à queue droite		DIN 338 – Forets à queue droite		DIN 8377 – Forets étagés à queue cône Morse
	DIN 1870 / 1 – Forets extra-longs à queue cône Morse		DIN 340 – Forets longs pointe à 118°		Normes DIN/ANSI
	DIN 1870 / 2 – Forets extra-longs à queue cône Morse		DIN 341 – Forets longs à queue cône Morse		Normes Dormer
	DIN 1897 – Forets extra-courts		DIN 345 – Forets courts à queue cône Morse		NAS907 – Forets pour l'aéronautique

REVÊTEMENT

	Nitride de chrome aluminium (avec processus de traitement d'arêtes)		Traitement de surface au bronze trempé (oxyde de bronze)		Revêtement nitride de titane aluminium (avec processus de traitement d'arêtes)
	Brillant (non revêtu)		Combinaison brillant et traitement vapeur		Nitride de titane aluminium
	Brillant et TiN (revêtement de pointe)		Traitement vapeur (oxyde)		Nitride de titane



FORETS MONOBLOCS – PRÉSENTATION DES ICÔNES

PROPRIÉTÉ D'ARROSAGE (CSP)



Arrosage centralisé

SENS DE COUPE



Rotation / coupe à gauche



Rotation / coupe à droite

CLASSE DE TOLÉRANCE DU DIAMÈTRE DE COUPE (TCDC)

DC
h8

h8 – Tolérance de perçage norme usine (selon diamètre)

DC
h7

h7 – Tolérance de perçage norme usine (selon diamètre)

DC
m7

m7 – Tolérance de perçage norme usine (selon diamètre)

DC
h6

h6 – Tolérance de perçage norme usine (selon diamètre)

CODE MATÉRIAU (BMC)

HM

Substrat dur (carbure monobloc)

HSS
HM

Acier rapide (corps) avec carbure monobloc (matériau de coupe)

HSS

Substrat acier rapide

HSS-E

Substrat acier rapide à teneur en cobalt

QUEUE



Queue cylindrique



Queue cylindrique avec tenon



Queue cône Morse



Queue cylindrique avec méplat



Queue cylindrique DIN 6535 HA



Queue cylindrique réduite en diamètre

FORME DE L'HÉLICE



Goujure hélice rapide



Goujure hélice standard



Technologie à âme mince continue (CTW, Continuously Thinned Web)



Goujure hélice lente



Goujure hélice rapide

VA

Amincissement spécial de la pointe

RAPPORT LONGUEUR UTILE DIAMÈTRE (ULDR)

1.25×D

1.25×D Rapport entre la profondeur utile de l'outil et son diamètre

2.5×D

2.5×D Rapport entre la profondeur utile de l'outil et son diamètre

5×D

5×D Rapport entre la profondeur utile de l'outil et son diamètre

1.5×D

1.5×D Rapport entre la profondeur utile de l'outil et son diamètre

20×D

20×D Rapport entre la profondeur utile de l'outil et son diamètre

6×D

6×D Rapport entre la profondeur utile de l'outil et son diamètre

10×D

10×D Rapport entre la profondeur utile de l'outil et son diamètre

25×D

25×D Rapport entre la profondeur utile de l'outil et son diamètre

8×D

8×D Rapport entre la profondeur utile de l'outil et son diamètre

15×D

15×D Rapport entre la profondeur utile de l'outil et son diamètre

3×D

3×D Rapport entre la profondeur utile de l'outil et son diamètre

1×D

1×D Rapport entre la profondeur utile de l'outil et son diamètre

4×D

4×D Rapport entre la profondeur utile de l'outil et son diamètre



FORETS CARBURE



FORCE X

FORETS CARBURE MONOBLOC HAUTE PERFORMANCE

DES FORETS DE PRODUCTION POLYVALENTS POUR UNE LARGE GAMME DE MATÉRIAUX

Les forets en carbure FORCE X ont été développés pour des applications d'usinage de haute performance dans une grande variété de matériaux, tels que les aciers au carbone ou alliés jusqu'à 1500 MPa et la fonte. Les forets FORCE X sont également performants dans l'acier inoxydable et l'aluminium, ce qui en fait un premier choix idéal pour les entreprises d'usinage en sous-traitance.

CARACTÉRISTIQUES ET AVANTAGES

- CTW  – Construction unique de la goujure avec un amincissement d'âme constant sur toute sa longueur.
- Pointe à 4 facettes avec affûtage en croix modifié avec angle plus important de l'arête de coupe secondaire.
- Substrat en carbure micrograin de première qualité avec revêtement TiAlN.
- Longueurs 3xD et 5xD disponibles avec ou sans arrosage centralisé.
- Longueur 8xD avec arrosage centralisé.

PAR RAPPORT AUX FORETS CONVENTIONNELS LES FORCE X SONT:

- **Remarquablement économique** - Peut être réaffûté plusieurs fois, ce qui augmente considérablement la durée de vie totale de l'outil.
- **Qualité et performances élevées et constantes** - avec une excellente précision de positionnement et un contrôle des copeaux garantissant une tolérance de trou et un état de surface de qualité supérieure.
- **Plus productif** - avec des vitesses de perçage élevées et une durée de vie prolongée de l'outil.



DÉTAILS DE LA GAMME

3xD



R457

Arrosage centralisé

R458

Sans trou d'arrosage

- 3.00 – 20.00 mm
- 1/8 – 3/4 inch, N30 – N1, A – Z

5xD



R453

Arrosage centralisé

R454

Sans trou d'arrosage

- 3.00 – 20.00 mm
- 1/8 – 3/4 inch, N30 – N1, A – Z

8xD



R459

Arrosage centralisé

- 3.00 – 16.00 mm
- 1/8 – 5/8 inch



FORCE X

FORETS CARBURE MONOBLOC HAUTE PERFORMANCE



EXEMPLES D'USINAGE

			Acier bas carbone P1.3	Acier allié P3.3	Fonte grise K1.2
Matériau			1.0718 (11SMnPb30)	1.6582 (34CrNiMo6)	0.6025 (GG-25)
Dureté		HB	180	325	215
Résistance		MPa	620	1120	260
Diamètre		mm	8 (R4578.0)	8 (R4598.0)	8 (R4538.0)
Profondeur		mm	3xD (24)	8xD (64)	5xD (40)
Vitesse de coupe	v_c	m/min	207	73	77
Avance	f	mm/tr	0.26	0.14	0.26
Arrosage			Emulsion 8% par le centre	Emulsion 8% par le centre	Emulsion 8% par le centre



FORCE M

FORETS POUR PRODUCTION DE GRANDES SÉRIES DANS L'ACIER INOXYDABLE

Les forets en carbure FORCE M ont été conçus pour offrir les meilleures performances et la plus grande fiabilité de processus lors du perçage des aciers inoxydables et des superalliages résistants à la chaleur. Les forets FORCE M sont idéaux pour les applications où il est nécessaire de percer un grand nombre de trous avec une précision élevée et constante.

CARACTÉRISTIQUES ET AVANTAGES

- CTW  – Construction unique de la goujure avec un amincissement d'âme constant sur toute sa longueur.
- Pointe à 4 facettes en forme de S avec affûtage en croix. Préparation de l'arête de coupe fine et précise. Conception renforcée de l'angle extérieur de l'arête.
- Substrat en carbure micrograin de première qualité avec revêtement TiAlN.
- Longueurs 3xD et 5xD avec arrosage centralisé.
- Longueur 8xD avec arrosage centralisé sur demande.

PAR RAPPORT AUX FORETS CONVENTIONNELS LES FORCE M SONT:

- **Des performances fiables** - avec une action de coupe douce qui empêche l'écroûissage et l'accumulation d'arêtes rapportées.
- **Productivité optimisée** - avec une excellente gestion des copeaux et une meilleure répartition des efforts pour permettre des taux de pénétration élevés.
- **Durée de vie exceptionnelle de l'outil** - avec l'angle renforcé et les arêtes de coupe qui résistent à l'usure par déformation.



DÉTAILS DE LA GAMME

3xD



R467

Arrosage centralisé

- 3.00 – 16.00 mm
- 1/8 – 5/8 inch

5xD



R463

Arrosage centralisé

- 3.00 – 16.00 mm
- 1/8 – 5/8 inch

8xD



R469

Arrosage centralisé

Available upon request

- 3.00 – 16.00 mm
- 1/8 – 5/8 inch



FORCE M



EXEMPLES D'USINAGE

			INOX ferritique M1.2	INOX austénitique M3.2	INOX très résistant M4.1
Matériau			1.4104 (AISI 430F)	1.4401 (AISI 316)	1.4501 (Super DUPLEX)
Dureté		HB	220	200	240
Résistance		MPa	700	750	770
Diamètre		mm	8 (R4678.0)	8 (S-R4698.0)	8 (R4638.0)
Profondeur		mm	3xD (24)	8xD (64)	5xD (40)
Vitesse de coupe	v_c	m/min	99	74	57
Avance	f	mm/tr	0.16	0.14	0.12
Arrosage			Emulsion 8% par le centre	Emulsion 8% par le centre	Emulsion 8% par le centre



FORCE N

FORETS À HAUT TAUX DE PÉNÉTRATION POUR L'ALUMINIUM

Les forets en carbure FORCE N sont recommandés pour les opérations de perçage à grande vitesse dans les alliages d'aluminium corroyés et coulés. La goujure et la géométrie de coupe sont spécialement conçues pour couper les copeaux en petits morceaux faciles à gérer afin d'en améliorer leur évacuation.

Les forets FORCE N offrent des performances et une durée de vie supérieures pour les entreprises ayant des volumes de fabrication moyen ou élevé.

CARACTÉRISTIQUES ET AVANTAGES

- Amincissement d'âme spéciale avec un angle d'hélice supérieur à la norme standard.
- Géométrie unique avec des arêtes de coupe convexes et une pointe autocentrante à 4 facettes.
- Substrat en carbure micrograin de première qualité avec finition brillante.
- Longueurs 5xD et 8xD avec arrosage centralisé sur demande.

PAR RAPPORT AUX FORETS CONVENTIONNELS LES FORCE N OFFRENT:

- **Des performances supérieures** - avec des vitesses de perçage élevées et une longue durée de vie.
- **Solution économique** - qui peut être utilisée pour tous les types d'aluminium, de l'aluminium tendre à l'aluminium abrasif.
- **Processus optimisé** - conçu pour réduire la force de poussée, améliorant la qualité du trou et réduisant la bavure de sortie qui se produit lors du perçage de matériaux mous.

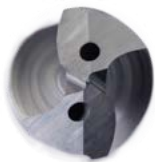

DÉTAILS DE LA GAMME

5xD



R445

Arrosage centralisé

Disponible sur demande

- 3.00 – 16.00 mm
- 1/8 – 5/8 inch

8xD



R448

Arrosage centralisé

Disponible sur demande

- 3.00 – 16.00 mm
- 1/8 – 5/8 inch

Up to
12xD

Plus grandes longueurs disponible sur demande



FORCE N

FORETS CARBURE MONOBLOC HAUTE PERFORMANCE



EXEMPLES D'USINAGE

			Aluminium corroyé N1.2	Aluminium coulé N2.2
Matériau			AW 2024-O (3.1355)	A242.0
Dureté		HB	50	75
Résistance		MPa	200	220
Diamètre		mm	8 mm (R4458.0)	8 mm (S-R4488.0)
Profondeur		mm	5xD (40)	8xD (64)
Vitesse de coupe	v_c	m/min	357	374
Avance	f	mm/tr	0.80	0.33
Arrosage			Emulsion 8% par le centre	Emulsion 8% par le centre

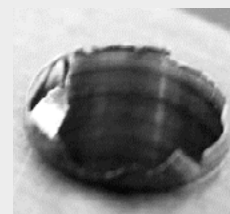

Bavure de sortie avec foret conventionnel

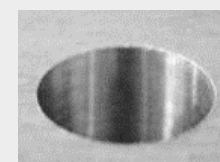

Bavure de sortie avec foret FORCE N



DORMER PRAMET

SUIVEZ-NOUS

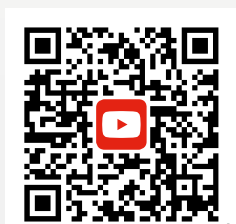

SHARE



LIKE



COMMENT



TAG



RE-TWEET







FORETS CARBURE – RECHERCHE PAR MATÉRIAU D'OUTIL

Carbures

Carbures (ou matériaux durs)		<p>Substrat fritté de la métallurgie des poudres, constitué d'un composite de carbure métallique avec un métal liant. La matière première essentielle est le carbure de tungstène (WC). C'est lui qui confère sa dureté au matériau. Le carbure de tantale (TaC), le carbure de titane (TiC) et le carbure de niobium (NbC) viennent compléter le WC pour obtenir les propriétés spécifiques recherchées. Ces trois matériaux sont appelés des « carbures cubiques ». Le cobalt (Co) sert de liant et assure donc l'homogénéité du matériau final.</p> <p>Les matériaux au carbure se caractérisent généralement par une haute résistance à la compression, une dureté élevée et donc une grande résistance à l'usure, mais aussi une résistance à la flexion et une ténacité limitées. Le carbure est utilisé dans la fabrication de tarauds, d'alésoirs, de fraises, de forets et de fraises à fileter.</p>
---	---	---

Revêtements de surface

Brillant (non revêtu)		La finition brillante (surface non revêtue) facilite le glissement des copeaux dans les matériaux non-ferreux ou doux, les plastiques et les matériaux composites, tout en préservant le tranchant des arêtes de coupe.
Revêtement nitrure de titane (TiN)		Le nitrure de titane est un revêtement céramique de couleur or appliqué par dépôt physique en phase vapeur (PVD). Une dureté élevée, associée à un faible frottement, permet d'augmenter la durée de vie des outils ou d'améliorer les performances de coupe des outils non revêtus.
Nitrure de titane aluminium (TiAlN)		Le nitrure de titane aluminium est un revêtement céramique multi-couche appliqué par procédé PVD. Il confère une ténacité et une stabilité à l'oxydation élevées. Ces propriétés en font un matériau idéal pour des vitesses et avances plus élevées, tout en améliorant la durée de vie des outils. Le TiAlN est utilisé dans le perçage, le taraudage et le fraisage. Il peut également convenir aux usinages sans refroidissement. Le revêtement TiAlN-Top est identique au TiAlN, mais il subit un traitement après revêtement pour lisser les imperfections, améliorer le flux de copeaux et réduire la formation d'arêtes rapportées.



Code de matériau du corps (BMC)		HM	HM	HM	HM	HM	HM	HM	HM	HM	HM	HM	HM	
Groupe standard de base (BSG)		DIN 333A	DORMER	DORMER	DORMER	DORMER	DORMER	DIN 6539	DIN 338	DIN 6539	DIN 338	DIN 6537K	DIN 6537K	DIN 6537L
Rapport longueur utile diamètre (ULDR)		1xD	1xD	1xD	1xD	1xD	3xD	2.5xD	4xD	2.5xD	4xD	3xD	3xD	5xD
Angle d'application		60°	120°	90°	150°	90°	90°	120°	120°	130°	130°	140°	140°	140°
Revêtement		Bright	Bright	Bright	TIAIN	TIAIN	TIAIN	Bright	Bright	TIN	TIN	TIAIN	TIAIN	TIAIN
Queue						DIN 6335HA	DIN 6335HA					DIN 6335HA	DIN 6335HA	DIN 6335HA
Forme d'hélice			λ 20-35°	λ 20-35°	λ 20-35°	λ 20-35°	λ 20-35°	λ 20-35°	λ 20-35°	λ 20-35°	λ 20-35°	CTW	CTW	CTW
Sens (direction de coupe)		R	R	R	R	R	R	R	R	R	R	R	R	R
Propriété d'alimentation en liquide de coupe (CSP)														
Code de famille de produits		R200	R122	R123	R125	R6011	R7131	R120	R100	R520	R510	R458	R457	R454
		1.00 - 5.00	5.00 - 20.00	5.00 - 20.00	6.00 - 16.00	6.00 - 16.00	3.30 - 10.40	1.00 - 12.00	1.00 - 14.00	3.00 - 16.50	3.00 - 14.25	3.00 - 20.00	3.00 - 20.00	3.00 - 20.00
		26	27	28	29	30	31	32	34	36	38	40	44	48
P	P1	■	■	■	■	■	■	■	■	■	■	■	■	■
	P2	■	■	■	■	■	■	■	■	■	■	■	■	■
	P3	■	■	■	■	■	■	■	■	■	■	■	■	■
	P4	■	■	■	■	■	■	■	■	■	■	■	■	■
M	M1		■	■	■	■	■			■	■	■	■	■
	M2		■	■	■	■	■			■	■	■	■	■
	M3		■	■	■	■	■				■	■	■	■
	M4											■	■	■
K	K1	■	■	■	■	■	■	■	■	■	■	■	■	■
	K2	■	■	■	■	■	■	■	■	■	■	■	■	■
	K3	■	■	■	■	■	■	■	■	■	■	■	■	■
	K4	■	■	■	■	■	■	■	■	■	■	■	■	■
	K5	■	■	■	■	■	■	■	■	■	■	■	■	■
N	N1	■	■	■	■	■	■	■	■	■	■	■	■	■
	N2	■	■	■	■	■	■	■	■	■	■	■	■	■
	N3	■	■	■	■	■	■	■	■	■	■	■	■	■
	N4		■	■	■	■	■			■	■	■	■	■
	N5													
S	S1		■	■	■	■		■		■	■	■	■	■
	S2		■	■	■	■		■						
	S3		■	■	■	■		■						
	S4		■	■	■	■		■						
H	H1		■	■	■	■		■	■	■	■	■	■	■
	H2		■	■	■	■		■	■	■	■	■	■	■
	H3		■	■	■	■		■	■	■	■	■	■	■
	H4													

■ Utilisation principale ■ Utilisation possible



HM	HM	HM	HM
DIN 6537L	>DORMER	DIN 6537K	DIN 6537L
5xD	8xD	3xD	5xD
DIN 6535HA	DIN 6535HA	DIN 6535HA	DIN 6535HA



FORCE X FORCE X FORCE M FORCE M

R453	R459	R467	R463
3.00 - 20.00	3.00 - 16.00	3.00 - 16.00	3.00 - 16.00
52	56	59	62

P1	■	■		
P2	■	■		
P3	■	■		
P4	■	■		
M1	☑	☑	■	■
M2	☑	☑	■	■
M3	☑	☑	■	■
M4	☑	☑	■	■
K1	■	■		
K2	■	■		
K3	■	■		
K4	■	■		
K5	■	■		
N1	■	☑		
N2	■	■		
N3	■	☑		
N4				
N5				
S1	■		■	■
S2			☑	☑
S3			☑	☑
S4			☑	☑
H1	■			
H2	☑			
H3	☑			
H4				

■ Utilisation principale ☑ Utilisation possible



R200



Foret à centrer en carbure monobloc, angle de pointe 118° et chanfrein à 60°, finition brillante

Foret possédant deux extrémités de perçage pour augmenter la productivité par outil, avec un angle de pointe à 118° et un lamage à 60°. Convient à un grand nombre de matériaux et sur toutes les machines CNC.

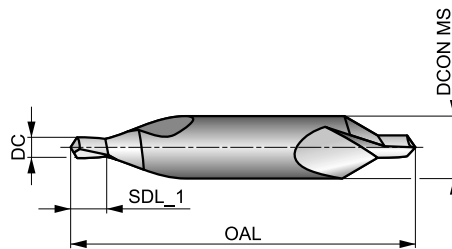

HM	DIN 333A	1xD
60°	Bright	
R		

Adéquation du groupe de matériaux de la pièce, valeurs de départ pour la vitesse de coupe (m/min) et code Alpha d'avance. Les tableaux d'avances par tour se trouvent à partir de la page 65.

P1.1 ■ 60 H	P1.2 ■ 67 H	P1.3 ■ 69 H	P2.1 ■ 51 H	P2.2 ■ 45 F	P2.3 ■ 40 D	P3.1 ■ 44 E	P3.2 ■ 36 E	P3.3 ■ 30 D	P4.1 ■ 26 E	P4.2 ■ 22 D	P4.3 ■ 18 C	K1.1 ■ 40 H	K1.2 ■ 30 E
K1.3 ■ 22 E	K2.1 ■ 37 D	K2.2 ■ 30 D	K2.3 ■ 24 D	K3.1 ■ 33 D	K3.2 ■ 25 D	K3.3 ■ 20 D	K4.1 ■ 30 D	K4.2 ■ 23 D	K4.3 ■ 17 D	K4.4 ■ 14 D	K4.5 ■ 12 D	K5.1 ■ 34 D	K5.2 ■ 26 D
K5.3 ■ 20 D	N1.1 ■ 120 I	N1.2 ■ 90 I	N1.3 ■ 60 H	N2.1 ■ 154 G	N2.2 ■ 138 G	N2.3 ■ 100 G	N3.1 ■ 169 G	N3.2 ■ 100 H	N3.3 ■ 50 F				

Produit	DC	DC	SDL_1	OAL	DCON MS
	(mm)	(inch)	(mm)	(mm)	(mm)
R2001.0X3.15	1.00	0.0394	1.7 - 1.3	31.0	3.15
R2001.25X3.15	1.25	0.0492	2.0 - 1.6	31.0	3.15
R2001.6X4.0	1.60	0.0630	2.6 - 2.0	35.0	4.00
R2002.0X5.0	2.00	0.0787	3.1 - 2.5	40.0	5.00
R2002.5X6.3	2.50	0.0984	3.8 - 3.1	45.0	6.30
R2003.15X8.0	3.15	0.1240	4.6 - 3.9	50.0	8.00
R2004.0X10.0	4.00	0.1575	5.9 - 5.0	55.0	10.00
R2005.0X12.5	5.00	0.1969	7.2 - 6.3	63.0	12.50



R122



Foret à pointer en carbure monobloc, angle de pointe 120°

Foret avec un angle de pointe conçu avec précision pour réaliser un guidage efficace facilitant le centrage du foret dans l'opération suivante. L'angle de pointe à 120° facilite l'auto-centrage et réduit les forces de coupe lors du perçage de nombreux matériaux.

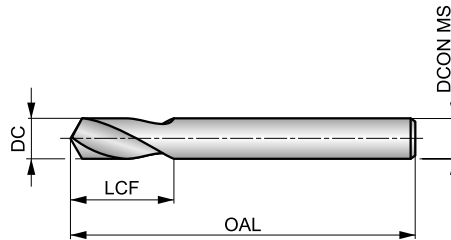

HM	DORMER	1xD
120°	Bright	
λ 20-35°	R	DC h6

Adéquation du groupe de matériaux de la pièce, valeurs de départ pour la vitesse de coupe (m/min) et code Alpha d'avance. Les tableaux d'avances par tour se trouvent à partir de la page 65.

P1.1 ■ 99 S	P1.2 ■ 111 S	P1.3 ■ 115 S	P2.1 ■ 85 S	P2.2 ■ 75 S	P2.3 ■ 66 S	P3.1 ■ 66 S	P3.2 ■ 53 S	P3.3 ■ 45 S	P4.1 ■ 40 S	P4.2 ■ 34 S	P4.3 ■ 27 S	M1.1 ■ 73 S	M1.2 ■ 61 S
M2.1 ■ 65 S	M2.2 ■ 53 S	M3.1 ■ 52 S	M3.2 ■ 45 S	K1.1 ■ 75 T	K1.2 ■ 56 T	K1.3 ■ 42 T	K2.1 ■ 68 T	K2.2 ■ 55 T	K2.3 ■ 44 T	K3.1 ■ 60 T	K3.2 ■ 46 T	K3.3 ■ 37 T	K4.1 ■ 55 T
K4.2 ■ 42 T	K4.3 ■ 31 T	K4.4 ■ 26 T	K4.5 ■ 22 T	K5.1 ■ 63 T	K5.2 ■ 47 T	K5.3 ■ 37 T	N1.1 ■ 200 V	N1.2 ■ 150 V	N1.3 ■ 100 V	N2.1 ■ 172 V	N2.2 ■ 155 V	N2.3 ■ 112 V	N3.1 ■ 423 V
N3.2 ■ 250 V	N3.3 ■ 125 V	N4.1 ■ 60 X	N4.2 ■ 100 V	S1.1 ■ 45 T	S1.2 ■ 35 T	S1.3 ■ 25 S	S2.1 ■ 40 S	S2.2 ■ 28 S	S3.1 ■ 30 S	S3.2 ■ 20 S	S4.1 ■ 23 S	S4.2 ■ 16 S	H1.1 ■ 56 S
H2.1 ■ 33 S	H2.2 ■ 36 S	H3.1 ■ 37 S	H3.2 ■ 30 S										

Produit	DC	DC	LCF	OAL	DCON MS
	(mm)	(inch)	(mm)	(mm)	(mm)
R1225.0	5.00	0.1969	16.0	62.0	5.00
R1226.0	6.00	0.2362	17.0	66.0	6.00
R1228.0	8.00	0.3150	22.0	79.0	8.00
R12210.0	10.00	0.3937	26.0	89.0	10.00
R12212.0	12.00	0.4724	30.0	102.0	12.00
R12216.0	16.00	0.6299	34.0	115.0	16.00
R12220.0	20.00	0.7874	40.0	131.0	20.00



R123



Foret à pointer en carbure monobloc, angle de pointe 90°

Foret avec un angle de pointe conçu avec précision pour réaliser un guidage efficace facilitant le centrage du foret dans l'opération suivante. L'angle de pointe à 90° facilite l'auto-centrage et réduit les forces de coupe lors du perçage de nombreux matériaux.

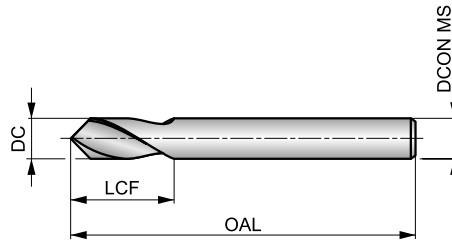

HM	DORMER	1xD
90°	Bright	
λ 20-35°	R	DC h6

Adéquation du groupe de matériaux de la pièce, valeurs de départ pour la vitesse de coupe (m/min) et code Alpha d'avance. Les tableaux d'avances par tour se trouvent à partir de la page 65.

P1.1 ■ 99 S	P1.2 ■ 111 S	P1.3 ■ 115 S	P2.1 ■ 85 S	P2.2 ■ 75 S	P2.3 ■ 66 S	P3.1 ■ 66 S	P3.2 ■ 53 S	P3.3 ■ 45 S	P4.1 ■ 40 S	P4.2 ■ 34 S	P4.3 ■ 27 S	M1.1 ■ 73 S	M1.2 ■ 61 S
M2.1 ■ 65 S	M2.2 ■ 53 S	M3.1 ■ 52 S	M3.2 ■ 45 S	K1.1 ■ 75 T	K1.2 ■ 56 T	K1.3 ■ 42 T	K2.1 ■ 68 T	K2.2 ■ 55 T	K2.3 ■ 44 T	K3.1 ■ 60 T	K3.2 ■ 46 T	K3.3 ■ 37 T	K4.1 ■ 55 T
K4.2 ■ 42 T	K4.3 ■ 31 T	K4.4 ■ 26 T	K4.5 ■ 22 T	K5.1 ■ 63 T	K5.2 ■ 47 T	K5.3 ■ 37 T	N1.1 ■ 200 V	N1.2 ■ 150 V	N1.3 ■ 100 V	N2.1 ■ 172 V	N2.2 ■ 155 V	N2.3 ■ 112 V	N3.1 ■ 423 V
N3.2 ■ 250 V	N3.3 ■ 125 V	N4.1 ■ 60 X	N4.2 ■ 100 V	S1.1 ■ 45 T	S1.2 ■ 35 T	S1.3 ■ 25 S	S2.1 ■ 40 S	S2.2 ■ 28 S	S3.1 ■ 30 S	S3.2 ■ 20 S	S4.1 ■ 23 S	S4.2 ■ 16 S	H1.1 ■ 56 S
H2.1 ■ 33 S	H2.2 ■ 36 S	H3.1 ■ 37 S	H3.2 ■ 30 S										

Produit	DC	DC	LCF	OAL	DCON MS
	(mm)	(inch)	(mm)	(mm)	(mm)
R1235.0	5.00	0.1969	16.0	62.0	5.00
R1236.0	6.00	0.2362	17.0	66.0	6.00
R1238.0	8.00	0.3150	22.0	79.0	8.00
R12310.0	10.00	0.3937	26.0	89.0	10.00
R12312.0	12.00	0.4724	30.0	102.0	12.00
R12316.0	16.00	0.6299	34.0	115.0	16.00
R12320.0	20.00	0.7874	40.0	131.0	20.00

NEW**R125****DORMER**

Foret à pointer en carbure monobloc, angle de pointe 150°, revêtement TiAlN

Foret avec un angle de pointe conçu avec précision pour réaliser un guidage efficace facilitant le centrage du foret dans l'opération suivante. L'angle de pointe à 150° facilite l'auto-centrage et réduit les forces de coupe lors du perçage de nombreux matériaux. Son revêtement TiAlN améliore les performances et prolonge la durée de vie de l'outil.

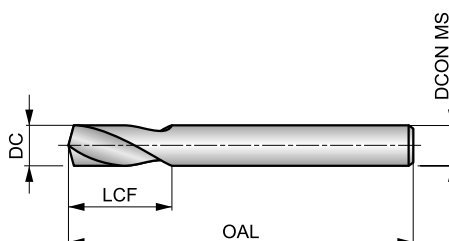

HM	DORMER	1×D
150°	TiAlN	
λ 20-35°	R	DC h6

Adéquation du groupe de matériaux de la pièce, valeurs de départ pour la vitesse de coupe (m/min) et code Alpha d'avance. Les tableaux d'avances par tour se trouvent à partir de la page 65.

P1.1 ■ 119 S	P1.2 ■ 134 S	P1.3 ■ 138 S	P2.1 ■ 102 S	P2.2 ■ 90 S	P2.3 ■ 80 S	P3.1 ■ 81 S	P3.2 ■ 65 S	P3.3 ■ 55 S	P4.1 ■ 48 S	P4.2 ■ 41 S	P4.3 ■ 34 S	M1.1 ■ 82 S	M1.2 ■ 70 S
M2.1 ■ 73 S	M2.2 ■ 60 S	M3.1 ■ 58 S	M3.2 ■ 50 S	K1.1 ■ 80 T	K1.2 ■ 59 T	K1.3 ■ 44 T	K2.1 ■ 86 T	K2.2 ■ 70 T	K2.3 ■ 56 T	K3.1 ■ 76 T	K3.2 ■ 58 T	K3.3 ■ 47 T	K4.1 ■ 71 T
K4.2 ■ 53 T	K4.3 ■ 39 T	K4.4 ■ 33 T	K4.5 ■ 28 T	K5.1 ■ 80 T	K5.2 ■ 60 T	K5.3 ■ 46 T	N1.1 ■ 200 V	N1.2 ■ 150 V	N1.3 ■ 100 V	N2.1 ■ 172 V	N2.2 ■ 155 V	N2.3 ■ 112 V	N3.1 ■ 423 V
N3.2 ■ 250 V	N3.3 ■ 125 V	N4.1 ■ 60 X	N4.2 ■ 100 V	S1.1 ■ 55 T	S1.2 ■ 45 T	S1.3 ■ 35 S	S2.1 ■ 53 S	S2.2 ■ 42 S	S3.1 ■ 40 S	S3.2 ■ 30 S	S4.1 ■ 31 S	S4.2 ■ 24 S	H1.1 ■ 56 S
H2.1 ■ 33 S	H2.2 ■ 36 S	H3.1 ■ 37 S	H3.2 ■ 30 S										

DCON MS tolérance h6.

Produit	DC (mm)	LCF (mm)	OAL (mm)	DCON MS (mm)
R1255.0	5.00	16.0	62.0	5.00
R1256.0	6.00	17.0	66.0	6.00
R1258.0	8.00	22.0	79.0	8.00
R12510.0	10.00	26.0	89.0	10.00
R12512.0	12.00	30.0	102.0	12.00
R12516.0	16.00	34.0	115.0	16.00



R6011



Foret à pointer en carbure monobloc, angle de pointe 90°, revêtement TiAlN

Foret avec un angle de pointe conçu avec précision pour réaliser un guidage efficace facilitant le centrage du foret dans l'opération suivante. L'angle de pointe à 90° facilite l'auto-centrage et réduit les forces de coupe lors du perçage de nombreux matériaux. Son revêtement TiAlN améliore les performances et prolonge la durée de vie de l'outil.

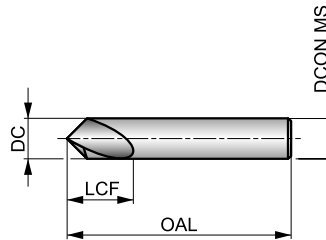

HM	DORMER	1xD
90°	TiAlN	DIN 6535HA
λ 20-35°	R	DC h6

Adéquation du groupe de matériaux de la pièce, valeurs de départ pour la vitesse de coupe (m/min) et code Alpha d'avance. Les tableaux d'avances par tour se trouvent à partir de la page 65.

P1.1 ■ 119 S	P1.2 ■ 134 S	P1.3 ■ 138 S	P2.1 ■ 102 S	P2.2 ■ 90 S	P2.3 ■ 80 S	P3.1 ■ 81 S	P3.2 ■ 65 S	P3.3 ■ 55 S	P4.1 ■ 48 S	P4.2 ■ 41 S	P4.3 ■ 34 S	M1.1 ■ 82 S	M1.2 ■ 70 S
M2.1 ■ 73 S	M2.2 ■ 60 S	M3.1 ■ 58 S	M3.2 ■ 50 S	K1.1 ■ 80 T	K1.2 ■ 59 T	K1.3 ■ 44 T	K2.1 ■ 86 T	K2.2 ■ 70 T	K2.3 ■ 56 T	K3.1 ■ 76 T	K3.2 ■ 58 T	K3.3 ■ 47 T	K4.1 ■ 71 T
K4.2 ■ 53 T	K4.3 ■ 39 T	K4.4 ■ 33 T	K4.5 ■ 28 T	K5.1 ■ 80 T	K5.2 ■ 60 T	K5.3 ■ 46 T	N1.1 ■ 200 V	N1.2 ■ 150 V	N1.3 ■ 100 V	N2.1 ■ 172 V	N2.2 ■ 155 V	N2.3 ■ 112 V	N3.1 ■ 423 V
N3.2 ■ 250 V	N3.3 ■ 125 V	N4.1 ■ 60 X	N4.2 ■ 100 V	S1.1 ■ 55 T	S1.2 ■ 45 T	S1.3 ■ 35 S	S2.1 ■ 53 S	S2.2 ■ 42 S	S3.1 ■ 40 S	S3.2 ■ 30 S	S4.1 ■ 31 S	S4.2 ■ 24 S	H1.1 ■ 56 S
H2.1 ■ 33 S	H2.2 ■ 36 S	H3.1 ■ 37 S	H3.2 ■ 30 S										

DCON MS tolérance h6.

Produit	DC	DC	LCF	OAL	DCON MS
	(mm)	(inch)	(mm)	(mm)	(mm)
R60116.0	6.00	0.2362	16.0	50.0	6.00
R601110.0	10.00	0.3937	25.0	70.0	10.00
R601116.0	16.00	0.6299	26.0	90.0	16.00



R7131



Foret étagé en carbure monobloc avec arrosage centralisé, revêtement TiAlN

Foret polyvalent avec des diamètres pilotes et des longueurs spécifiques adaptés à la réalisation de filetages métriques. Le perçage et le chanfreinage en une seule opération réduisent le temps de cycle et les stocks d'outils. Angle de pointe à 140° et chanfrein à 90°. Le revêtement TiAlN améliore les performances et prolonge la durée de vie de l'outil. Convient pour le perçage de nombreux matériaux.

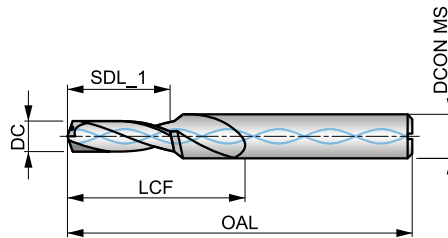

HM	DORMER	3xD
90°	TiAlN	DIN 6535HA
λ 20-35°	R	
DC m7		

Adéquation du groupe de matériaux de la pièce, valeurs de départ pour la vitesse de coupe (m/min) et code Alpha d'avance. Les tableaux d'avances par tour se trouvent à partir de la page 65.

P1.1 ■ 139 W	P1.2 ■ 156 W	P1.3 ■ 161 W	P2.1 ■ 119 W	P2.2 ■ 105 W	P2.3 ■ 93 V	P3.1 ■ 96 V	P3.2 ■ 77 V	P3.3 ■ 65 V	P4.1 ■ 57 V	P4.2 ■ 48 V	M1.1 ■ 62 V	M1.2 ■ 52 V	M2.1 ■ 55 V
M2.2 ■ 45 V	M3.1 ■ 47 V	M3.2 ■ 40 V	M3.3 ■ 36 U	M4.1 ■ 35 U	K1.1 ■ 90 W	K1.2 ■ 67 W	K1.3 ■ 50 W	K2.1 ■ 92 V	K2.2 ■ 75 V	K2.3 ■ 60 V	K3.1 ■ 82 V	K3.2 ■ 62 V	K3.3 ■ 50 V
K4.1 ■ 76 V	K4.2 ■ 57 V	K4.3 ■ 42 V	K4.4 ■ 36 V	K4.5 ■ 30 V	K5.1 ■ 86 V	K5.2 ■ 64 V	K5.3 ■ 50 V	N1.1 ■ 250 W	N1.2 ■ 188 W	N1.3 ■ 125 W	N2.1 ■ 308 V	N2.2 ■ 277 V	N2.3 ■ 200 V
N3.1 ■ 373 W	N3.2 ■ 220 W	N3.3 ■ 110 W											

DCON MS tolérance h6.

Produit	DC	DC	SDL_1	LCF	OAL	DCON MS	TDZ
	(mm)	(inch)	(mm)	(mm)	(mm)	(mm)	
R71313.3	3.30	0.1299	11.40	20.0	66.0	6.00	M4
R71314.2	4.20	0.1654	13.60	24.0	66.0	6.00	M5
R71315.0	5.00	0.1969	16.50	28.0	79.0	8.00	M6
R71316.8	6.80	0.2677	21.00	34.0	89.0	10.00	M8
R71318.5	8.50	0.3346	25.50	47.0	102.0	12.00	M10
R713110.2	10.20	0.4016	30.00	55.0	107.0	14.00	M12
R713110.4	10.40	0.4094	30.00	55.0	107.0	14.00	M12



R120



Foret carbure monobloc type N longueur 2,5xD, finition brillante

Foret avec résistance à l'usure améliorée pour une productivité accrue et une durée de vie d'outil prolongée. Une pointe à 120° à 4 facettes aide à l'auto-centrage et réduit les forces de coupe. Adapté au perçage de matériaux durs et abrasifs, il peut être utilisé sur tous types de machines CNC.

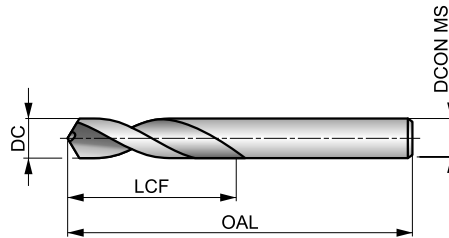

HM	DIN 6539	2.5xD
120°	Bright	
λ 20-35°	R	DC h7

Adéquation du groupe de matériaux de la pièce, valeurs de départ pour la vitesse de coupe (m/min) et code Alpha d'avance. Les tableaux d'avances par tour se trouvent à partir de la page 65.

P1.1 □99 S	P1.2 □111 S	P1.3 □115 S	P2.1 □85 S	P2.2 □75 S	P2.3 □66 S	P3.1 □66 S	P3.2 □53 S	P3.3 □45 S	P4.1 □40 S	P4.2 □34 S	P4.3 □27 S	K1.1 □75 U	K1.2 □56 U
K1.3 □42 U	K2.1 □68 U	K2.2 □55 U	K2.3 □44 U	K3.1 □60 U	K3.2 □46 U	K3.3 □37 U	K4.1 □55 U	K4.2 □42 U	K4.3 □31 U	K4.4 □26 U	K4.5 □22 U	K5.1 □63 U	K5.2 □47 U
K5.3 □37 U	N1.1 ■200 W	N1.2 ■150 W	N1.3 □100 W	N2.1 □172 W	N2.2 □155 W	N2.3 □112 W	N3.1 □466 W	N3.2 □275 W	N3.3 ■138 W	N4.1 ■60 U	N4.2 ■100 U	S1.1 ■45 T	S1.2 □35 T
S1.3 □25 T	S2.1 □40 T	S2.2 □28 T	S3.1 □30 T	S3.2 □20 T	S4.1 □23 T	S4.2 □16 T	H1.1 □56 S	H2.1 □33 S	H2.2 □36 S	H3.1 □37 S	H3.2 □30 S		

Produit	DC	DC	LCF	OAL	DCON MS
	(mm)	(inch)			
R1201.0	1.00	0.0394	6.0	26.0	1.00
R1201.1	1.10	0.0433	7.0	28.0	1.10
R1201.2	1.20	0.0472	8.0	30.0	1.20
R1201.3	1.30	0.0512	8.0	30.0	1.30
R1201.4	1.40	0.0551	9.0	32.0	1.40
R1201.5	1.50	0.0591	9.0	32.0	1.50
R1201.6	1.60	0.0630	10.0	34.0	1.60
R1201.7	1.70	0.0669	10.0	34.0	1.70
R1201.8	1.80	0.0709	11.0	36.0	1.80
R1201.9	1.90	0.0748	11.0	36.0	1.90
R1202.0	2.00	0.0787	12.0	38.0	2.00
R1202.1	2.10	0.0827	12.0	38.0	2.10
R1202.2	2.20	0.0866	13.0	40.0	2.20
R1202.3	2.30	0.0906	13.0	40.0	2.30
R1202.4	2.40	0.0945	14.0	43.0	2.40
R1202.5	2.50	0.0984	14.0	43.0	2.50
R1202.6	2.60	0.1024	14.0	43.0	2.60
R1202.7	2.70	0.1063	16.0	46.0	2.70
R1202.8	2.80	0.1102	16.0	46.0	2.80
R1202.9	2.90	0.1142	16.0	46.0	2.90
R1203.0	3.00	0.1181	16.0	46.0	3.00
R1203.1	3.10	0.1220	18.0	49.0	3.10
R1203.2	3.20	0.1260	18.0	49.0	3.20
R1203.3	3.30	0.1299	18.0	49.0	3.30
R1203.4	3.40	0.1339	20.0	52.0	3.40
R1203.5	3.50	0.1378	20.0	52.0	3.50

Produit	DC	DC	LCF	OAL	DCON MS
	(mm)	(inch)			
R1203.6	3.60	0.1417	20.0	52.0	3.60
R1203.7	3.70	0.1457	20.0	52.0	3.70
R1203.8	3.80	0.1496	22.0	55.0	3.80
R1203.9	3.90	0.1535	22.0	55.0	3.90
R1204.0	4.00	0.1575	22.0	55.0	4.00
R1204.1	4.10	0.1614	22.0	55.0	4.10
R1204.2	4.20	0.1654	22.0	55.0	4.20
R1204.3	4.30	0.1693	24.0	58.0	4.30
R1204.4	4.40	0.1732	24.0	58.0	4.40
R1204.5	4.50	0.1772	24.0	58.0	4.50
R1204.6	4.60	0.1811	24.0	58.0	4.60
R1204.7	4.70	0.1850	24.0	58.0	4.70
R1204.8	4.80	0.1890	26.0	62.0	4.80
R1204.9	4.90	0.1929	26.0	62.0	4.90
R1205.0	5.00	0.1969	26.0	62.0	5.00
R1205.1	5.10	0.2008	26.0	62.0	5.10
R1205.2	5.20	0.2047	26.0	62.0	5.20
R1205.3	5.30	0.2087	26.0	62.0	5.30
R1205.4	5.40	0.2126	28.0	66.0	5.40
R1205.5	5.50	0.2165	28.0	66.0	5.50
R1205.6	5.60	0.2205	28.0	66.0	5.60
R1205.7	5.70	0.2244	28.0	66.0	5.70
R1205.8	5.80	0.2283	28.0	66.0	5.80
R1205.9	5.90	0.2323	28.0	66.0	5.90
R1206.0	6.00	0.2362	28.0	66.0	6.00
R1206.1	6.10	0.2402	31.0	70.0	6.10



Produit	DC	DC	LCF	OAL	DCON MS
	(mm)	(inch)	(mm)	(mm)	(mm)
R1206.2	6.20	0.2441	31.0	70.0	6.20
R1206.3	6.30	0.2480	31.0	70.0	6.30
R1206.4	6.40	0.2520	31.0	70.0	6.40
R1206.5	6.50	0.2559	31.0	70.0	6.50
R1206.6	6.60	0.2598	31.0	70.0	6.60
R1206.7	6.70	0.2638	31.0	70.0	6.70
R1206.8	6.80	0.2677	34.0	74.0	6.80
R1206.9	6.90	0.2717	34.0	74.0	6.90
R1207.0	7.00	0.2756	34.0	74.0	7.00
R1207.1	7.10	0.2795	34.0	74.0	7.10
R1207.2	7.20	0.2835	34.0	74.0	7.20
R1207.3	7.30	0.2874	34.0	74.0	7.30
R1207.4	7.40	0.2913	34.0	74.0	7.40
R1207.5	7.50	0.2953	34.0	74.0	7.50
R1207.6	7.60	0.2992	37.0	79.0	7.60
R1207.7	7.70	0.3031	37.0	79.0	7.70
R1207.8	7.80	0.3071	37.0	79.0	7.80
R1207.9	7.90	0.3110	37.0	79.0	7.90
R1208.0	8.00	0.3150	37.0	79.0	8.00
R1208.1	8.10	0.3189	37.0	79.0	8.10
R1208.2	8.20	0.3228	37.0	79.0	8.20
R1208.3	8.30	0.3268	37.0	79.0	8.30

Produit	DC	DC	LCF	OAL	DCON MS
	(mm)	(inch)	(mm)	(mm)	(mm)
R1208.4	8.40	0.3307	37.0	79.0	8.40
R1208.5	8.50	0.3346	37.0	79.0	8.50
R1208.6	8.60	0.3386	40.0	84.0	8.60
R1208.7	8.70	0.3425	40.0	84.0	8.70
R1208.8	8.80	0.3465	40.0	84.0	8.80
R1208.9	8.90	0.3504	40.0	84.0	8.90
R1209.0	9.00	0.3543	40.0	84.0	9.00
R1209.1	9.10	0.3583	40.0	84.0	9.10
R1209.2	9.20	0.3622	40.0	84.0	9.20
R1209.3	9.30	0.3661	40.0	84.0	9.30
R1209.4	9.40	0.3701	40.0	84.0	9.40
R1209.5	9.50	0.3740	40.0	84.0	9.50
R1209.6	9.60	0.3780	43.0	89.0	9.60
R1209.7	9.70	0.3819	43.0	89.0	9.70
R1209.8	9.80	0.3858	43.0	89.0	9.80
R1209.9	9.90	0.3898	43.0	89.0	9.90
R12010.0	10.00	0.3937	43.0	89.0	10.00
R12010.2	10.20	0.4016	43.0	89.0	10.20
R12010.5	10.50	0.4134	43.0	89.0	10.50
R12011.0	11.00	0.4331	47.0	95.0	11.00
R12011.5	11.50	0.4528	47.0	95.0	11.50
R12012.0	12.00	0.4724	51.0	102.0	12.00



R100



Foret carbure monobloc type N longueur 4xD, finition brillante

Foret avec résistance à l'usure améliorée pour une productivité accrue et une durée de vie d'outil prolongée. Une pointe à 120° à 4 facettes aide à l'auto-centrage et réduit les forces de coupe. Peut être utilisé sur tous types de machines CNC.

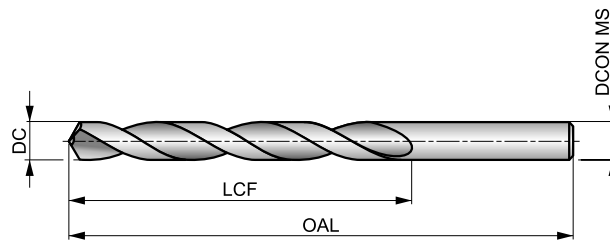

HM	DIN 338	4xD
120°	Bright	
λ 20-35°	R	DC h7

Adéquation du groupe de matériaux de la pièce, valeurs de départ pour la vitesse de coupe (m/min) et code Alpha d'avance. Les tableaux d'avances par tour se trouvent à partir de la page 65.

P1.1 □99 S	P1.2 □111 S	P1.3 □115 S	P2.1 □85 S	P2.2 □75 S	P2.3 □66 S	P3.1 □66 S	P3.2 □53 S	P3.3 □45 S	P4.1 □40 S	P4.2 □34 S	P4.3 □27 S	K1.1 □75 T	K1.2 □56 T
K1.3 □42 T	K2.1 □68 T	K2.2 □55 T	K2.3 □44 T	K3.1 □60 T	K3.2 □46 T	K3.3 □37 T	K4.1 □55 T	K4.2 □42 T	K4.3 □31 T	K4.4 □26 T	K4.5 □22 T	K5.1 □63 T	K5.2 □47 T
K5.3 □37 T	N1.1 □200 V	N1.2 □150 V	N1.3 □100 V	N2.1 □172 V	N2.2 □155 V	N2.3 □112 V	N3.1 ■423 V	N3.2 ■250 V	N4.1 ■60 X	N4.2 ■100 V	H1.1 □56 S	H2.1 □33 S	H2.2 □36 S
H3.1 □37 S	H3.2 □30 S												

Produit	DC	DC	LCF	OAL	DCON MS
	(mm)	(inch)			
R1001.0	1.00	0.0394	12.0	34.0	1.00
R1001.1	1.10	0.0433	14.0	36.0	1.10
R1001.2	1.20	0.0472	16.0	38.0	1.20
R1001.3	1.30	0.0512	16.0	38.0	1.30
R1001.4	1.40	0.0551	18.0	40.0	1.40
R1001.5	1.50	0.0591	18.0	40.0	1.50
R1001.6	1.60	0.0630	20.0	43.0	1.60
R1001.7	1.70	0.0669	20.0	43.0	1.70
R1001.8	1.80	0.0709	22.0	46.0	1.80
R1001.9	1.90	0.0748	22.0	46.0	1.90
R1002.0	2.00	0.0787	24.0	49.0	2.00
R1002.1	2.10	0.0827	24.0	49.0	2.10
R1002.2	2.20	0.0866	27.0	53.0	2.20
R1002.3	2.30	0.0906	27.0	53.0	2.30
R1002.4	2.40	0.0945	30.0	57.0	2.40
R1002.5	2.50	0.0984	30.0	57.0	2.50
R1002.6	2.60	0.1024	30.0	57.0	2.60
R1002.7	2.70	0.1063	33.0	61.0	2.70
R1002.8	2.80	0.1102	33.0	61.0	2.80
R1002.9	2.90	0.1142	33.0	61.0	2.90
R1003.0	3.00	0.1181	33.0	61.0	3.00
R1003.1	3.10	0.1220	36.0	65.0	3.10
R1003.2	3.20	0.1260	36.0	65.0	3.20
R1003.3	3.30	0.1299	36.0	65.0	3.30
R1003.4	3.40	0.1339	39.0	70.0	3.40
R1003.5	3.50	0.1378	39.0	70.0	3.50

Produit	DC	DC	LCF	OAL	DCON MS
	(mm)	(inch)			
R1003.6	3.60	0.1417	39.0	70.0	3.60
R1003.7	3.70	0.1457	39.0	70.0	3.70
R1003.8	3.80	0.1496	43.0	75.0	3.80
R1003.9	3.90	0.1535	43.0	75.0	3.90
R1004.0	4.00	0.1575	43.0	75.0	4.00
R1004.1	4.10	0.1614	43.0	75.0	4.10
R1004.2	4.20	0.1654	43.0	75.0	4.20
R1004.3	4.30	0.1693	47.0	80.0	4.30
R1004.4	4.40	0.1732	47.0	80.0	4.40
R1004.5	4.50	0.1772	47.0	80.0	4.50
R1004.6	4.60	0.1811	47.0	80.0	4.60
R1004.7	4.70	0.1850	47.0	80.0	4.70
R1004.8	4.80	0.1890	52.0	86.0	4.80
R1004.9	4.90	0.1929	52.0	86.0	4.90
R1005.0	5.00	0.1969	52.0	86.0	5.00
R1005.1	5.10	0.2008	52.0	86.0	5.10
R1005.2	5.20	0.2047	52.0	86.0	5.20
R1005.3	5.30	0.2087	52.0	86.0	5.30
R1005.4	5.40	0.2126	57.0	93.0	5.40
R1005.5	5.50	0.2165	57.0	93.0	5.50
R1005.6	5.60	0.2205	57.0	93.0	5.60
R1005.7	5.70	0.2244	57.0	93.0	5.70
R1005.8	5.80	0.2283	57.0	93.0	5.80
R1005.9	5.90	0.2323	57.0	93.0	5.90
R1006.0	6.00	0.2362	57.0	93.0	6.00
R1006.1	6.10	0.2402	63.0	101.0	6.10



Produit	DC	DC	LCF	OAL	DCON MS
	(mm)	(inch)	(mm)	(mm)	(mm)
R1006.2	6.20	0.2441	63.0	101.0	6.20
R1006.3	6.30	0.2480	63.0	101.0	6.30
R1006.4	6.40	0.2520	63.0	101.0	6.40
R1006.5	6.50	0.2559	63.0	101.0	6.50
R1006.6	6.60	0.2598	63.0	101.0	6.60
R1006.7	6.70	0.2638	63.0	101.0	6.70
R1006.8	6.80	0.2677	69.0	109.0	6.80
R1006.9	6.90	0.2717	69.0	109.0	6.90
R1007.0	7.00	0.2756	69.0	109.0	7.00
R1007.1	7.10	0.2795	69.0	109.0	7.10
R1007.2	7.20	0.2835	69.0	109.0	7.20
R1007.3	7.30	0.2874	69.0	109.0	7.30
R1007.4	7.40	0.2913	69.0	109.0	7.40
R1007.5	7.50	0.2953	69.0	109.0	7.50
R1007.6	7.60	0.2992	75.0	117.0	7.60
R1007.7	7.70	0.3031	75.0	117.0	7.70
R1007.8	7.80	0.3071	75.0	117.0	7.80
R1007.9	7.90	0.3110	75.0	117.0	7.90
R1008.0	8.00	0.3150	75.0	117.0	8.00
R1008.1	8.10	0.3189	75.0	117.0	8.10
R1008.2	8.20	0.3228	75.0	117.0	8.20
R1008.3	8.30	0.3268	75.0	117.0	8.30
R1008.4	8.40	0.3307	75.0	117.0	8.40

Produit	DC	DC	LCF	OAL	DCON MS
	(mm)	(inch)	(mm)	(mm)	(mm)
R1008.5	8.50	0.3346	75.0	117.0	8.50
R1008.6	8.60	0.3386	81.0	125.0	8.60
R1008.7	8.70	0.3425	81.0	125.0	8.70
R1008.8	8.80	0.3465	81.0	125.0	8.80
R1008.9	8.90	0.3504	81.0	125.0	8.90
R1009.0	9.00	0.3543	81.0	125.0	9.00
R1009.1	9.10	0.3583	81.0	125.0	9.10
R1009.2	9.20	0.3622	81.0	125.0	9.20
R1009.3	9.30	0.3661	81.0	125.0	9.30
R1009.4	9.40	0.3701	81.0	125.0	9.40
R1009.5	9.50	0.3740	81.0	125.0	9.50
R1009.6	9.60	0.3780	87.0	133.0	9.60
R1009.7	9.70	0.3819	87.0	133.0	9.70
R1009.8	9.80	0.3858	87.0	133.0	9.80
R1009.9	9.90	0.3898	87.0	133.0	9.90
R10010.0	10.00	0.3937	87.0	133.0	10.00
R10010.2	10.20	0.4016	87.0	133.0	10.20
R10010.5	10.50	0.4134	87.0	133.0	10.50
R10011.0	11.00	0.4331	94.0	142.0	11.00
R10011.5	11.50	0.4528	94.0	142.0	11.50
R10012.0	12.00	0.4724	101.0	151.0	12.00
R10013.0	13.00	0.5118	101.0	151.0	13.00
R10014.0	14.00	0.5512	108.0	160.0	14.00



R520



Foret carbure monobloc CDX longueur 2,5xD, revêtement TiN

Foret court haute performance capable de produire des trous précis de haute qualité à des vitesses et des avances élevées (tolérance de trou H8). L'angle de pointe à 130° favorise l'auto-centrage et réduit les efforts de coupe. Le revêtement TiN améliore les performances et prolonge la durée de vie de l'outil. Convient à toutes les machines CNC et à de nombreux matériaux.

CDX

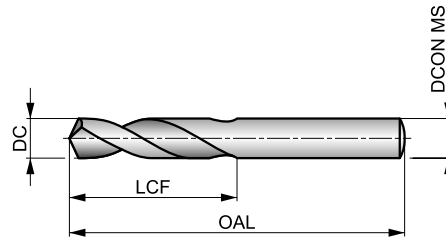

HM	DIN 6539	2.5xD
130°	TiN	
λ 20-35°	R	DC h7

Adéquation du groupe de matériaux de la pièce, valeurs de départ pour la vitesse de coupe (m/min) et code Alpha d'avance. Les tableaux d'avances par tour se trouvent à partir de la page 65.

P1.1 ■ 119 X	P1.2 ■ 134 X	P1.3 ■ 138 X	P2.1 ■ 102 X	P2.2 ■ 90 X	P2.3 ■ 80 X	P3.1 ■ 81 X	P3.2 ■ 65 X	P3.3 ■ 55 X	P4.1 ■ 48 X	P4.2 ■ 41 X	P4.3 ■ 34 W	M1.1 ■ 69 W	M1.2 ■ 58 W
M2.1 ■ 61 W	M2.2 ■ 50 W	K1.1 ■ 90 Y	K1.2 ■ 67 Y	K1.3 ■ 50 Y	K2.1 ■ 80 X	K2.2 ■ 65 X	K2.3 ■ 52 X	K3.1 ■ 71 X	K3.2 ■ 54 X	K3.3 ■ 44 X	K4.1 ■ 66 X	K4.2 ■ 49 X	K4.3 ■ 36 X
K4.4 ■ 31 X	K4.5 ■ 26 X	K5.1 ■ 74 X	K5.2 ■ 56 X	K5.3 ■ 43 X	N1.1 ■ 225 Z	N1.2 ■ 169 Z	N1.3 ■ 113 Z	N2.1 ■ 231 Y	N2.2 ■ 208 Y	N2.3 ■ 150 Y	N4.1 ■ 75 Z	N4.2 ■ 115 V	S1.1 ■ 60 W
S1.2 ■ 45 V	S1.3 ■ 35 U	H1.1 ■ 65 U	H2.1 ■ 38 U	H2.2 ■ 36 T	H3.1 ■ 43 U	H3.2 ■ 35 U							

DCON MS tolérance h7.

Produit	DC	DC	DC	LCF	OAL	DCON MS
	(inch)	(mm)	(inch)	(mm)	(mm)	(mm)
R5203.0	–	3.00	0.1181	16.0	46.0	3.00
R5203.1	–	3.10	0.1220	18.0	49.0	3.10
R5201/8	1/8	3.18	0.1252	18.0	49.0	3.18
R5203.2	–	3.20	0.1260	18.0	49.0	3.20
R5203.3	–	3.30	0.1299	18.0	49.0	3.30
R5203.4	–	3.40	0.1339	20.0	52.0	3.40
R5203.5	–	3.50	0.1378	20.0	52.0	3.50
R5203.6	–	3.60	0.1417	20.0	52.0	3.60
R5203.7	–	3.70	0.1457	20.0	52.0	3.70
R5203.8	–	3.80	0.1496	22.0	55.0	3.80
R5203.9	–	3.90	0.1535	22.0	55.0	3.90
R5204.0	–	4.00	0.1575	22.0	55.0	4.00
R5204.1	–	4.10	0.1614	22.0	55.0	4.10
R5204.2	–	4.20	0.1654	22.0	55.0	4.20
R5204.3	–	4.30	0.1693	24.0	58.0	4.30
R5204.4	–	4.40	0.1732	24.0	58.0	4.40
R5204.5	–	4.50	0.1772	24.0	58.0	4.50
R5204.6	–	4.60	0.1811	24.0	58.0	4.60
R5204.7	–	4.70	0.1850	24.0	58.0	4.70
R5204.8	–	4.80	0.1890	26.0	62.0	4.80
R5204.9	–	4.90	0.1929	26.0	62.0	4.90
R5205.0	–	5.00	0.1969	26.0	62.0	5.00
R5205.1	–	5.10	0.2008	26.0	62.0	5.10
R5205.2	–	5.20	0.2047	26.0	62.0	5.20
R5205.3	–	5.30	0.2087	26.0	62.0	5.30

Produit	DC	DC	DC	LCF	OAL	DCON MS
	(inch)	(mm)	(inch)	(mm)	(mm)	(mm)
R5205.4	–	5.40	0.2126	28.0	66.0	5.40
R5205.5	–	5.50	0.2165	28.0	66.0	5.50
R5205.6	–	5.60	0.2205	28.0	66.0	5.60
R5205.7	–	5.70	0.2244	28.0	66.0	5.70
R5205.8	–	5.80	0.2283	28.0	66.0	5.80
R5205.9	–	5.90	0.2323	28.0	66.0	5.90
R5206.0	–	6.00	0.2362	28.0	66.0	6.00
R5206.1	–	6.10	0.2402	31.0	70.0	6.10
R5206.2	–	6.20	0.2441	31.0	70.0	6.20
R5206.3	–	6.30	0.2480	31.0	70.0	6.30
R5201/4	1/4	6.35	0.2500	31.0	70.0	6.35
R5206.4	–	6.40	0.2520	31.0	70.0	6.40
R5206.5	–	6.50	0.2559	31.0	70.0	6.50
R5206.6	–	6.60	0.2598	31.0	70.0	6.60
R5206.7	–	6.70	0.2638	31.0	70.0	6.70
R5206.8	–	6.80	0.2677	34.0	74.0	6.80
R5206.9	–	6.90	0.2717	34.0	74.0	6.90
R5207.0	–	7.00	0.2756	34.0	74.0	7.00
R5207.1	–	7.10	0.2795	34.0	74.0	7.10
R5207.2	–	7.20	0.2835	34.0	74.0	7.20
R5207.3	–	7.30	0.2874	34.0	74.0	7.30
R5207.4	–	7.40	0.2913	34.0	74.0	7.40
R5207.5	–	7.50	0.2953	34.0	74.0	7.50
R5207.6	–	7.60	0.2992	37.0	79.0	7.60
R5207.7	–	7.70	0.3031	37.0	79.0	7.70



Produit	DC	DC	DC	LCF	OAL	DCON MS
	(inch)	(mm)	(inch)	(mm)	(mm)	(mm)
R5207.8	–	7.80	0.3071	37.0	79.0	7.80
R5207.9	–	7.90	0.3110	37.0	79.0	7.90
R5205/16	5/16	7.94	0.3126	37.0	79.0	7.94
R5208.0	–	8.00	0.3150	37.0	79.0	8.00
R5208.1	–	8.10	0.3189	37.0	79.0	8.10
R5208.2	–	8.20	0.3228	37.0	79.0	8.20
R5208.3	–	8.30	0.3268	37.0	79.0	8.30
R5208.4	–	8.40	0.3307	37.0	79.0	8.40
R5208.5	–	8.50	0.3346	37.0	79.0	8.50
R5208.6	–	8.60	0.3386	40.0	84.0	8.60
R5208.7	–	8.70	0.3425	40.0	84.0	8.70
R5208.8	–	8.80	0.3465	40.0	84.0	8.80
R5208.9	–	8.90	0.3504	40.0	84.0	8.90
R5209.0	–	9.00	0.3543	40.0	84.0	9.00
R5209.1	–	9.10	0.3583	40.0	84.0	9.10
R5209.2	–	9.20	0.3622	40.0	84.0	9.20
R5209.3	–	9.30	0.3661	40.0	84.0	9.30
R5209.4	–	9.40	0.3701	40.0	84.0	9.40
R5209.5	–	9.50	0.3740	40.0	84.0	9.50
R5203/8	3/8	9.52	0.3748	43.0	89.0	9.52
R5209.6	–	9.60	0.3780	43.0	89.0	9.60
R5209.7	–	9.70	0.3819	43.0	89.0	9.70
R5209.8	–	9.80	0.3858	43.0	89.0	9.80
R5209.9	–	9.90	0.3898	43.0	89.0	9.90

Produit	DC	DC	DC	LCF	OAL	DCON MS
	(inch)	(mm)	(inch)	(mm)	(mm)	(mm)
R52010.0	–	10.00	0.3937	43.0	89.0	10.00
R52010.1	–	10.10	0.3976	43.0	89.0	10.10
R52010.2	–	10.20	0.4016	43.0	89.0	10.20
R52010.3	–	10.30	0.4055	43.0	89.0	10.30
R52010.4	–	10.40	0.4094	43.0	89.0	10.40
R52010.5	–	10.50	0.4134	43.0	89.0	10.50
R52011.0	–	11.00	0.4331	47.0	95.0	11.00
R5207/16	7/16	11.11	0.4374	47.0	95.0	11.11
R52011.2	–	11.20	0.4409	47.0	95.0	11.20
R52011.5	–	11.50	0.4528	47.0	95.0	11.50
R52012.0	–	12.00	0.4724	51.0	102.0	12.00
R52012.5	–	12.50	0.4921	51.0	102.0	12.50
R5201/2	1/2	12.70	0.5000	51.0	102.0	12.70
R52013.0	–	13.00	0.5118	51.0	102.0	13.00
R52013.5	–	13.50	0.5315	54.0	107.0	13.50
R52014.0	–	14.00	0.5512	54.0	107.0	14.00
R52014.2	–	14.20	0.5591	56.0	111.0	14.20
R52014.25	–	14.25	0.5610	56.0	111.0	14.25
R52014.5	–	14.50	0.5709	56.0	111.0	14.50
R52015.0	–	15.00	0.5906	56.0	111.0	15.00
R52015.1	–	15.10	0.5945	58.0	115.0	15.10
R5205/8	5/8	15.88	0.6252	58.0	115.0	15.88
R52016.0	–	16.00	0.6299	58.0	115.0	16.00
R52016.5	–	16.50	0.6496	60.0	119.0	16.50



R510



Foret carbure monobloc CDX longueur 4xD, revêtement TiN

Foret haute performance capable de produire des trous précis de haute qualité à des vitesses et des avances élevées (tolérance de trou H8). La pointe à 130° favorise l'auto-centrage et réduit les efforts de coupe. Le revêtement TiN améliore les performances et prolonge la durée de vie de l'outil. Convient à toutes les machines CNC et dans de nombreux matériaux.



CDX

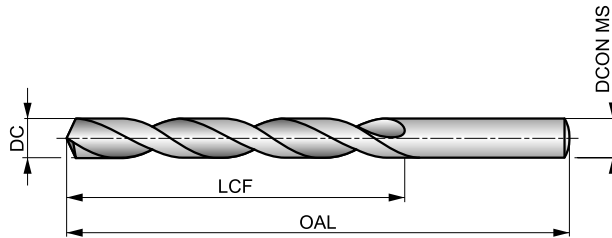

HM	DIN 338	4xD
130°	TiN	
λ 20-35°	R	DC h7

Adéquation du groupe de matériaux de la pièce, valeurs de départ pour la vitesse de coupe (m/min) et code Alpha d'avance. Les tableaux d'avances par tour se trouvent à partir de la page 65.

P1.1 ■ 119 W	P1.2 ■ 134 W	P1.3 ■ 138 W	P2.1 ■ 102 W	P2.2 ■ 90 W	P2.3 ■ 80 V	P3.1 ■ 81 W	P3.2 ■ 65 W	P3.3 ■ 55 V	P4.1 ■ 48 W	P4.2 ■ 41 V	P4.3 ■ 34 V	M1.1 ■ 69 V	M1.2 ■ 58 V
M2.1 ■ 61 V	M2.2 ■ 50 V	K1.1 ■ 90 X	K1.2 ■ 67 X	K1.3 ■ 50 X	K2.1 ■ 80 W	K2.2 ■ 65 W	K2.3 ■ 52 W	K3.1 ■ 71 W	K3.2 ■ 54 W	K3.3 ■ 44 W	K4.1 ■ 66 W	K4.2 ■ 49 W	K4.3 ■ 36 W
K4.4 ■ 31 W	K4.5 ■ 26 W	K5.1 ■ 74 W	K5.2 ■ 56 W	K5.3 ■ 43 W	N1.1 ■ 225 Y	N1.2 ■ 169 Y	N1.3 ■ 113 Y	N2.1 ■ 231 X	N2.2 ■ 208 X	N2.3 ■ 150 X	N4.1 ■ 75 X	N4.2 ■ 115 V	S1.1 ■ 45 V
H1.1 ■ 65 T	H2.1 ■ 38 T	H2.2 ■ 36 S	H3.1 ■ 43 T	H3.2 ■ 35 T									

DCON MS tolérance h7.

Produit	DC	DC	DC	LCF	OAL	DCON MS
	(inch)	(mm)	(inch)	(mm)	(mm)	(mm)
R5103.0	–	3.00	0.1181	33.0	61.0	3.00
R5101/8	1/8	3.18	0.1252	36.0	65.0	3.18
R5103.2	–	3.20	0.1260	36.0	65.0	3.20
R5103.3	–	3.30	0.1299	36.0	65.0	3.30
R5103.4	–	3.40	0.1339	39.0	70.0	3.40
R5103.5	–	3.50	0.1378	39.0	70.0	3.50
R5103.7	–	3.70	0.1457	39.0	70.0	3.70
R5103.9	–	3.90	0.1535	43.0	75.0	3.90
R5104.0	–	4.00	0.1575	43.0	75.0	4.00
R5104.1	–	4.10	0.1614	43.0	75.0	4.10
R5104.2	–	4.20	0.1654	43.0	75.0	4.20
R5104.3	–	4.30	0.1693	47.0	80.0	4.30
R5104.5	–	4.50	0.1772	47.0	80.0	4.50
R5104.6	–	4.60	0.1811	47.0	80.0	4.60
R5104.7	–	4.70	0.1850	47.0	80.0	4.70
R5103/16	3/16	4.76	0.1874	52.0	86.0	4.76
R5104.9	–	4.90	0.1929	52.0	86.0	4.90
R5105.0	–	5.00	0.1969	52.0	86.0	5.00
R5105.1	–	5.10	0.2008	52.0	86.0	5.10
R5105.5	–	5.50	0.2165	57.0	93.0	5.50
R5105.6	–	5.60	0.2205	57.0	93.0	5.60
R5105.7	–	5.70	0.2244	57.0	93.0	5.70
R5106.0	–	6.00	0.2362	57.0	93.0	6.00
R5101/4	1/4	6.35	0.2500	63.0	101.0	6.35
R5106.5	–	6.50	0.2559	63.0	101.0	6.50

Produit	DC	DC	DC	LCF	OAL	DCON MS
	(inch)	(mm)	(inch)	(mm)	(mm)	(mm)
R5106.6	–	6.60	0.2598	63.0	101.0	6.60
R5106.8	–	6.80	0.2677	69.0	109.0	6.80
R5106.9	–	6.90	0.2717	69.0	109.0	6.90
R5107.0	–	7.00	0.2756	69.0	109.0	7.00
R5107.3	–	7.30	0.2874	69.0	109.0	7.30
R5107.4	–	7.40	0.2913	69.0	109.0	7.40
R5107.5	–	7.50	0.2953	69.0	109.0	7.50
R5107.8	–	7.80	0.3071	75.0	117.0	7.80
R5107.9	–	7.90	0.3110	75.0	117.0	7.90
R5105/16	5/16	7.94	0.3126	75.0	117.0	7.94
R5108.0	–	8.00	0.3150	75.0	117.0	8.00
R5108.5	–	8.50	0.3346	75.0	117.0	8.50
R5108.7	–	8.70	0.3425	81.0	125.0	8.70
R5108.8	–	8.80	0.3465	81.0	125.0	8.80
R5109.0	–	9.00	0.3543	81.0	125.0	9.00
R5109.2	–	9.20	0.3622	81.0	125.0	9.20
R5109.3	–	9.30	0.3661	81.0	125.0	9.30
R5109.4	–	9.40	0.3701	81.0	125.0	9.40
R5109.5	–	9.50	0.3740	81.0	125.0	9.50
R5103/8	3/8	9.52	0.3748	87.0	133.0	9.52
R5109.9	–	9.90	0.3898	87.0	133.0	9.90
R51010.0	–	10.00	0.3937	87.0	133.0	10.00
R51010.2	–	10.20	0.4016	87.0	133.0	10.20
R51010.3	–	10.30	0.4055	87.0	133.0	10.30
R51010.4	–	10.40	0.4094	87.0	133.0	10.40



Produit	DC	DC	DC	LCF	OAL	D CON MS
	(inch)	(mm)	(inch)	(mm)	(mm)	(mm)
R51010.5	–	10.50	0.4134	87.0	133.0	10.50
R51010.8	–	10.80	0.4252	94.0	142.0	10.80
R51011.0	–	11.00	0.4331	94.0	142.0	11.00
R5107/16	7/16	11.11	0.4374	94.0	142.0	11.11
R51011.2	–	11.20	0.4409	94.0	142.0	11.20
R51011.5	–	11.50	0.4528	94.0	142.0	11.50

Produit	DC	DC	DC	LCF	OAL	D CON MS
	(inch)	(mm)	(inch)	(mm)	(mm)	(mm)
R51012.0	–	12.00	0.4724	101.0	151.0	12.00
R5101/2	1/2	12.70	0.5000	101.0	151.0	12.70
R51013.0	–	13.00	0.5118	101.0	151.0	13.00
R51014.0	–	14.00	0.5512	108.0	160.0	14.00
R51014.25	–	14.25	0.5610	114.0	169.0	14.25



R458



Foret carbure monobloc FORCE X longueur 3xD, revêtement TiAlN

Foret haute performance multi-applications capable de produire des trous précis de haute qualité à des vitesses et des avances élevées (tolérance de trou H9). Pointe auto-centrante à 140° avec 4 facettes et une conception de goujure CTW pour un débit copeaux optimum. Le revêtement TiAlN augmente la dureté en surface et améliore la durée de vie de l'outil.

FORCE X

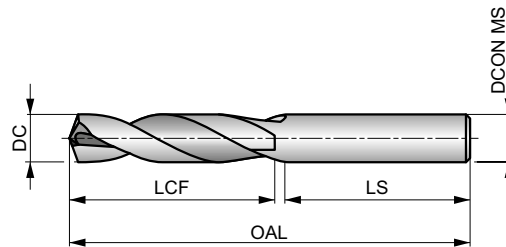

HM	DIN 6537K	3xD
140°	TiAlN	DIN 6535HA
CTW	DC m7	

Adéquation du groupe de matériaux de la pièce, valeurs de départ pour la vitesse de coupe (m/min) et code Alpha d'avance. Les tableaux d'avances par tour se trouvent à partir de la page 65.

P1.1 ■ 143 W	P1.2 ■ 160 W	P1.3 ■ 166 W	P2.1 ■ 122 W	P2.2 ■ 108 W	P2.3 ■ 95 V	P3.1 ■ 106 V	P3.2 ■ 86 V	P3.3 ■ 72 V	P4.1 ■ 63 V	P4.2 ■ 54 V	P4.3 ■ 44 U	M1.1 ■ 60 U	M1.2 ■ 51 U
M2.1 ■ 54 U	M2.2 ■ 44 U	M2.3 ■ 37 T	M3.1 ■ 33 T	M3.2 ■ 28 T	M3.3 ■ 26 T	M4.1 ■ 24 T	M4.2 ■ 21 T	K1.1 ■ 88 W	K1.2 ■ 65 W	K1.3 ■ 49 W	K2.1 ■ 78 V	K2.2 ■ 64 V	K2.3 ■ 51 V
K3.1 ■ 70 V	K3.2 ■ 54 V	K3.3 ■ 43 V	K4.1 ■ 65 V	K4.2 ■ 49 V	K4.3 ■ 36 V	K4.4 ■ 30 V	K4.5 ■ 26 V	K5.1 ■ 73 V	K5.2 ■ 55 V	K5.3 ■ 42 V	N1.1 ■ 200 W	N1.2 ■ 150 W	N1.3 ■ 100 W
N2.1 ■ 246 V	N2.2 ■ 222 V	N2.3 ■ 160 V	N3.1 ■ 298 V	N3.2 ■ 176 V	N3.3 ■ 88 V	S1.1 ■ 44 U	S1.2 ■ 36 U	S1.3 ■ 32 T	H1.1 ■ 45 U	H2.1 ■ 26 U	H2.2 ■ 24 U	H3.1 ■ 30 U	H3.2 ■ 24 U

DCON MS tolérance h6.

Produit	DC	DC	DC	LCF	OAL	LS	DCON MS
	(inch)	(mm)	(inch)	(mm)	(mm)	(mm)	(mm)
R4583.0	–	3.00	0.1181	20.0	62.0	36.0	6.00
R4583.1	–	3.10	0.1220	20.0	62.0	36.0	6.00
R4581/8	1/8	3.18	0.1250	20.0	62.0	36.0	6.00
R4583.2	–	3.20	0.1260	20.0	62.0	36.0	6.00
R458N30	N30	3.26	0.1283	20.0	62.0	36.0	6.00
R4583.3	–	3.30	0.1299	20.0	62.0	36.0	6.00
R4583.4	–	3.40	0.1339	20.0	62.0	36.0	6.00
R458N29	N29	3.45	0.1360	20.0	62.0	36.0	6.00
R4583.5	–	3.50	0.1378	20.0	62.0	36.0	6.00
R458N28	N28	3.57	0.1406	20.0	62.0	36.0	6.00
R4589/64	9/64	3.57	0.1406	20.0	62.0	36.0	6.00
R4583.6	–	3.60	0.1417	20.0	62.0	36.0	6.00
R458N27	N27	3.66	0.1441	20.0	62.0	36.0	6.00
R4583.7	–	3.70	0.1457	20.0	62.0	36.0	6.00
R4583.73	–	3.73	0.1469	24.0	66.0	36.0	6.00
R458N26	N26	3.73	0.1469	24.0	66.0	36.0	6.00
R458N25	N25	3.80	0.1496	24.0	66.0	36.0	6.00
R4583.8	–	3.80	0.1496	24.0	66.0	36.0	6.00
R458N24	N24	3.86	0.1520	24.0	66.0	36.0	6.00
R4583.9	–	3.90	0.1535	24.0	66.0	36.0	6.00
R458N23	N23	3.91	0.1539	24.0	66.0	36.0	6.00
R4585/32	5/32	3.97	0.1563	24.0	66.0	36.0	6.00
R458N22	N22	3.99	0.1571	24.0	66.0	36.0	6.00
R4584.0	–	4.00	0.1575	24.0	66.0	36.0	6.00
R458N21	N21	4.04	0.1591	24.0	66.0	36.0	6.00



Produit	DC	DC	DC	LCF	OAL	LS	DCON MS
	(inch)	(mm)	(inch)	(mm)	(mm)	(mm)	(mm)
R458N20	N20	4.09	0.1610	24.0	66.0	36.0	6.00
R4584.1	–	4.10	0.1614	24.0	66.0	36.0	6.00
R4584.2	–	4.20	0.1654	24.0	66.0	36.0	6.00
R458N19	N19	4.22	0.1661	24.0	66.0	36.0	6.00
R4584.3	–	4.30	0.1693	24.0	66.0	36.0	6.00
R458N18	N18	4.31	0.1697	24.0	66.0	36.0	6.00
R45811/64	11/64	4.37	0.1719	24.0	66.0	36.0	6.00
R458N17	N17	4.39	0.1728	24.0	66.0	36.0	6.00
R4584.4	–	4.40	0.1732	24.0	66.0	36.0	6.00
R4584.5	–	4.50	0.1772	24.0	66.0	36.0	6.00
R458N16	N16	4.50	0.1772	24.0	66.0	36.0	6.00
R458N15	N15	4.57	0.1799	24.0	66.0	36.0	6.00
R4584.6	–	4.60	0.1811	24.0	66.0	36.0	6.00
R458N14	N14	4.62	0.1819	24.0	66.0	36.0	6.00
R458N13	N13	4.70	0.1850	24.0	66.0	36.0	6.00
R4584.7	–	4.70	0.1850	24.0	66.0	36.0	6.00
R4583/16	3/16	4.76	0.1875	28.0	66.0	36.0	6.00
R4584.8	–	4.80	0.1890	28.0	66.0	36.0	6.00
R458N12	N12	4.80	0.1890	28.0	66.0	36.0	6.00
R458N11	N11	4.85	0.1909	28.0	66.0	36.0	6.00
R4584.9	–	4.90	0.1929	28.0	66.0	36.0	6.00
R458N10	N10	4.92	0.1937	28.0	66.0	36.0	6.00
R458N9	N9	4.98	0.1961	28.0	66.0	36.0	6.00
R4585.0	–	5.00	0.1969	28.0	66.0	36.0	6.00
R458N8	N8	5.06	0.1992	28.0	66.0	36.0	6.00
R4585.1	–	5.10	0.2008	28.0	66.0	36.0	6.00
R458N7	N7	5.11	0.2010	28.0	66.0	36.0	6.00
R45813/64	13/64	5.16	0.2031	28.0	66.0	36.0	6.00
R458N6	N6	5.18	0.2039	28.0	66.0	36.0	6.00
R4585.2	–	5.20	0.2047	28.0	66.0	36.0	6.00
R458N5	N5	5.22	0.2055	28.0	66.0	36.0	6.00
R4585.3	–	5.30	0.2087	28.0	66.0	36.0	6.00
R458N4	N4	5.31	0.2091	28.0	66.0	36.0	6.00
R4585.4	–	5.40	0.2126	28.0	66.0	36.0	6.00
R458N3	N3	5.41	0.2130	28.0	66.0	36.0	6.00
R4585.5	–	5.50	0.2165	28.0	66.0	36.0	6.00
R4587/32	7/32	5.56	0.2188	28.0	66.0	36.0	6.00
R4585.6	–	5.60	0.2205	28.0	66.0	36.0	6.00
R458N2	N2	5.61	0.2209	28.0	66.0	36.0	6.00
R4585.7	–	5.70	0.2244	28.0	66.0	36.0	6.00
R458N1	N1	5.79	0.2280	28.0	66.0	36.0	6.00
R4585.8	–	5.80	0.2283	28.0	66.0	36.0	6.00
R4585.9	–	5.90	0.2323	28.0	66.0	36.0	6.00
R458A	A	5.94	0.2339	28.0	66.0	36.0	6.00
R45815/64	15/64	5.95	0.2344	28.0	66.0	36.0	6.00
R4586.0	–	6.00	0.2362	28.0	66.0	36.0	6.00
R458B	B	6.05	0.2380	34.0	79.0	36.0	8.00
R4586.1	–	6.10	0.2402	34.0	79.0	36.0	8.00
R458C	C	6.15	0.2421	34.0	79.0	36.0	8.00
R4586.2	–	6.20	0.2441	34.0	79.0	36.0	8.00
R458D	D	6.25	0.2461	34.0	79.0	36.0	8.00
R4586.3	–	6.30	0.2480	34.0	79.0	36.0	8.00
R4581/4	1/4	6.35	0.2500	34.0	79.0	36.0	8.00
R458E	E	6.35	0.2500	34.0	79.0	36.0	8.00
R4586.4	–	6.40	0.2520	34.0	79.0	36.0	8.00
R4586.5	–	6.50	0.2559	34.0	79.0	36.0	8.00
R458F	F	6.53	0.2571	34.0	79.0	36.0	8.00
R4586.6	–	6.60	0.2598	34.0	79.0	36.0	8.00
R458G	G	6.63	0.2610	34.0	79.0	36.0	8.00
R4586.7	–	6.70	0.2638	34.0	79.0	36.0	8.00
R45817/64	17/64	6.75	0.2656	34.0	79.0	36.0	8.00
R458H	H	6.76	0.2661	34.0	79.0	36.0	8.00
R4586.8	–	6.80	0.2677	34.0	79.0	36.0	8.00
R4586.9	–	6.90	0.2717	34.0	79.0	36.0	8.00
R458I	I	6.91	0.2720	34.0	79.0	36.0	8.00



Produit	DC	DC	DC	LCF	OAL	LS	DCON MS
	(inch)	(mm)	(inch)	(mm)	(mm)	(mm)	(mm)
R4587.0	—	7.00	0.2756	34.0	79.0	36.0	8.00
R458J	J	7.04	0.2772	34.0	79.0	36.0	8.00
R4587.1	—	7.10	0.2795	41.0	79.0	36.0	8.00
R458K	K	7.14	0.2811	41.0	79.0	36.0	8.00
R4589/32	9/32	7.14	0.2813	41.0	79.0	36.0	8.00
R4587.2	—	7.20	0.2835	41.0	79.0	36.0	8.00
R4587.3	—	7.30	0.2874	41.0	79.0	36.0	8.00
R458L	L	7.37	0.2902	41.0	79.0	36.0	8.00
R4587.4	—	7.40	0.2913	41.0	79.0	36.0	8.00
R458M	M	7.49	0.2949	41.0	79.0	36.0	8.00
R4587.5	—	7.50	0.2953	41.0	79.0	36.0	8.00
R45819/64	19/64	7.54	0.2969	41.0	79.0	36.0	8.00
R4587.6	—	7.60	0.2992	41.0	79.0	36.0	8.00
R458N	N	7.67	0.3020	41.0	79.0	36.0	8.00
R4587.7	—	7.70	0.3031	41.0	79.0	36.0	8.00
R4587.8	—	7.80	0.3071	41.0	79.0	36.0	8.00
R4587.9	—	7.90	0.3110	41.0	79.0	36.0	8.00
R4585/16	5/16	7.94	0.3125	41.0	79.0	36.0	8.00
R4588.0	—	8.00	0.3150	41.0	79.0	36.0	8.00
R458O	O	8.03	0.3161	47.0	89.0	40.0	10.00
R4588.1	—	8.10	0.3189	47.0	89.0	40.0	10.00
R4588.2	—	8.20	0.3228	47.0	89.0	40.0	10.00
R458P	P	8.20	0.3228	47.0	89.0	40.0	10.00
R4588.3	—	8.30	0.3268	47.0	89.0	40.0	10.00
R45821/64	21/64	8.33	0.3281	47.0	89.0	40.0	10.00
R4588.4	—	8.40	0.3307	47.0	89.0	40.0	10.00
R458Q	Q	8.43	0.3319	47.0	89.0	40.0	10.00
R4588.5	—	8.50	0.3346	47.0	89.0	40.0	10.00
R4588.6	—	8.60	0.3386	47.0	89.0	40.0	10.00
R458R	R	8.61	0.3390	47.0	89.0	40.0	10.00
R4588.7	—	8.70	0.3425	47.0	89.0	40.0	10.00
R45811/32	11/32	8.73	0.3438	47.0	89.0	40.0	10.00
R4588.8	—	8.80	0.3465	47.0	89.0	40.0	10.00
R458S	S	8.84	0.3480	47.0	89.0	40.0	10.00
R4588.9	—	8.90	0.3504	47.0	89.0	40.0	10.00
R4589.0	—	9.00	0.3543	47.0	89.0	40.0	10.00
R458T	T	9.09	0.3579	47.0	89.0	40.0	10.00
R4589.1	—	9.10	0.3583	47.0	89.0	40.0	10.00
R45823/64	23/64	9.13	0.3594	47.0	89.0	40.0	10.00
R4589.2	—	9.20	0.3622	47.0	89.0	40.0	10.00
R4589.3	—	9.30	0.3661	47.0	89.0	40.0	10.00
R458U	U	9.35	0.3681	47.0	89.0	40.0	10.00
R4589.4	—	9.40	0.3701	47.0	89.0	40.0	10.00
R4589.5	—	9.50	0.3740	47.0	89.0	40.0	10.00
R4583/8	3/8	9.53	0.3750	47.0	89.0	40.0	10.00
R458V	V	9.58	0.3772	47.0	89.0	40.0	10.00
R4589.6	—	9.60	0.3780	47.0	89.0	40.0	10.00
R4589.7	—	9.70	0.3819	47.0	89.0	40.0	10.00
R4589.8	—	9.80	0.3858	47.0	89.0	40.0	10.00
R458W	W	9.80	0.3858	47.0	89.0	40.0	10.00
R4589.9	—	9.90	0.3898	47.0	89.0	40.0	10.00
R45825/64	25/64	9.92	0.3906	47.0	89.0	40.0	10.00
R45810.0	—	10.00	0.3937	47.0	89.0	40.0	10.00
R458X	X	10.08	0.3969	55.0	102.0	45.0	12.00
R45810.1	—	10.10	0.3976	55.0	102.0	45.0	12.00
R45810.2	—	10.20	0.4016	55.0	102.0	45.0	12.00
R458Y	Y	10.26	0.4039	55.0	102.0	45.0	12.00
R45810.3	—	10.30	0.4055	55.0	102.0	45.0	12.00
R45813/32	13/32	10.32	0.4063	55.0	102.0	45.0	12.00
R45810.4	—	10.40	0.4094	55.0	102.0	45.0	12.00
R458Z	Z	10.49	0.4130	55.0	102.0	45.0	12.00
R45810.5	—	10.50	0.4134	55.0	102.0	45.0	12.00
R45810.6	—	10.60	0.4173	55.0	102.0	45.0	12.00
R45810.7	—	10.70	0.4213	55.0	102.0	45.0	12.00
R45827/64	27/64	10.72	0.4219	55.0	102.0	45.0	12.00



Produit	DC	DC	DC	LCF	OAL	LS	DCON MS
	(inch)	(mm)	(inch)	(mm)	(mm)	(mm)	(mm)
R45810.8	–	10.80	0.4252	55.0	102.0	45.0	12.00
R45810.9	–	10.90	0.4291	55.0	102.0	45.0	12.00
R45811.0	–	11.00	0.4331	55.0	102.0	45.0	12.00
R45811.1	–	11.10	0.4370	55.0	102.0	45.0	12.00
R4587/16	7/16	11.11	0.4375	55.0	102.0	45.0	12.00
R45811.2	–	11.20	0.4409	55.0	102.0	45.0	12.00
R45811.3	–	11.30	0.4449	55.0	102.0	45.0	12.00
R45811.4	–	11.40	0.4488	55.0	102.0	45.0	12.00
R45811.5	–	11.50	0.4528	55.0	102.0	45.0	12.00
R45829/64	29/64	11.51	0.4531	55.0	102.0	45.0	12.00
R45811.6	–	11.60	0.4567	55.0	102.0	45.0	12.00
R45811.7	–	11.70	0.4606	55.0	102.0	45.0	12.00
R45811.8	–	11.80	0.4646	55.0	102.0	45.0	12.00
R45811.9	–	11.90	0.4685	55.0	102.0	45.0	12.00
R45815/32	15/32	11.91	0.4688	55.0	102.0	45.0	12.00
R45812.0	–	12.00	0.4724	55.0	102.0	45.0	12.00
R45812.1	–	12.10	0.4764	60.0	107.0	45.0	14.00
R45812.2	–	12.20	0.4803	60.0	107.0	45.0	14.00
R45831/64	31/64	12.30	0.4844	60.0	107.0	45.0	14.00
R45812.5	–	12.50	0.4921	60.0	107.0	45.0	14.00
R45812.7	–	12.70	0.5000	60.0	107.0	45.0	14.00
R4581/2	1/2	12.70	0.5000	60.0	107.0	45.0	14.00
R45812.8	–	12.80	0.5039	60.0	107.0	45.0	14.00
R45813.0	–	13.00	0.5118	60.0	107.0	45.0	14.00
R45833/64	33/64	13.10	0.5156	60.0	107.0	45.0	14.00
R45813.3	–	13.30	0.5236	60.0	107.0	45.0	14.00
R45817/32	17/32	13.49	0.5313	60.0	107.0	45.0	14.00
R45813.5	–	13.50	0.5315	60.0	107.0	45.0	14.00
R45813.8	–	13.80	0.5433	60.0	107.0	45.0	14.00
R45835/64	35/64	13.89	0.5469	60.0	107.0	45.0	14.00
R45814.0	–	14.00	0.5512	60.0	107.0	45.0	14.00
R45814.25	–	14.25	0.5610	65.0	115.0	48.0	16.00
R4589/16	9/16	14.29	0.5625	65.0	115.0	48.0	16.00
R45814.5	–	14.50	0.5709	65.0	115.0	48.0	16.00
R45837/64	37/64	14.68	0.5781	65.0	115.0	48.0	16.00
R45814.8	–	14.80	0.5827	65.0	115.0	48.0	16.00
R45815.0	–	15.00	0.5906	65.0	115.0	48.0	16.00
R45819/32	19/32	15.08	0.5938	65.0	115.0	48.0	16.00
R45815.1	–	15.10	0.5945	65.0	115.0	48.0	16.00
R45815.3	–	15.30	0.6024	65.0	115.0	48.0	16.00
R45839/64	39/64	15.48	0.6094	65.0	115.0	48.0	16.00
R45815.5	–	15.50	0.6102	65.0	115.0	48.0	16.00
R45815.8	–	15.80	0.6220	65.0	115.0	48.0	16.00
R4585/8	5/8	15.88	0.6250	65.0	115.0	48.0	16.00
R45816.0	–	16.00	0.6299	65.0	115.0	48.0	16.00
R45841/64	41/64	16.27	0.6406	73.0	123.0	48.0	18.00
R45816.5	–	16.50	0.6496	73.0	123.0	48.0	18.00
R45821/32	21/32	16.67	0.6563	73.0	123.0	48.0	18.00
R45817.0	–	17.00	0.6693	73.0	123.0	48.0	18.00
R45843/64	43/64	17.07	0.6720	73.0	123.0	48.0	18.00
R45811/16	11/16	17.46	0.6874	73.0	123.0	48.0	18.00
R45817.5	–	17.50	0.6890	73.0	123.0	48.0	18.00
R45817.8	–	17.80	0.7008	73.0	123.0	48.0	18.00
R45845/64	45/64	17.86	0.7031	73.0	123.0	48.0	18.00
R45818.0	–	18.00	0.7087	73.0	123.0	48.0	18.00
R45823/32	23/32	18.26	0.7189	79.0	131.0	50.0	20.00
R45818.5	–	18.50	0.7283	79.0	131.0	50.0	20.00
R45847/64	47/64	18.65	0.7343	79.0	131.0	50.0	20.00
R45819.0	–	19.00	0.7480	79.0	131.0	50.0	20.00
R4583/4	–	19.05	0.7500	79.0	131.0	50.0	20.00
R45819.5	–	19.50	0.7677	79.0	131.0	50.0	20.00
R45819.8	–	19.80	0.7795	79.0	131.0	50.0	20.00
R45820.0	–	20.00	0.7874	79.0	131.0	50.0	20.00



R457



Foret carbure monobloc FORCE X longueur 3xD avec arrosage centralisé, revêtement TiAlN

Foret haute performance multi-applications capable de produire des trous précis de haute qualité à des vitesses et des avances élevées (tolérance de trou H9). Pointe auto-centrante à 140° avec 4 facettes et une conception de goujure CTW pour un débit copeaux optimum. L'arrosage centralisé améliore l'évacuation des copeaux. Le revêtement TiAlN augmente la dureté en surface et améliore la durée de vie de l'outil.

FORCE X

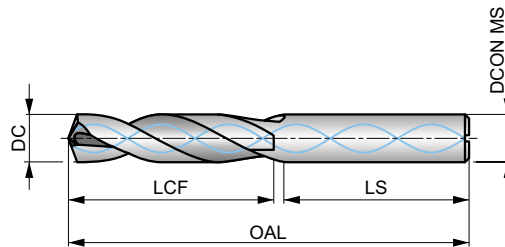

HM	DIN 6537K	3xD
140°	TiAlN	DIN 6535HA
CTW	DC m7	

Adéquation du groupe de matériaux de la pièce, valeurs de départ pour la vitesse de coupe (m/min) et code Alpha d'avance. Les tableaux d'avances par tour se trouvent à partir de la page 65.

P1.1 ■ 179 W	P1.2 ■ 200 W	P1.3 ■ 207 W	P2.1 ■ 153 W	P2.2 ■ 135 W	P2.3 ■ 119 V	P3.1 ■ 133 V	P3.2 ■ 107 V	P3.3 ■ 90 V	P4.1 ■ 79 V	P4.2 ■ 67 V	P4.3 ■ 55 U	M1.1 ■ 75 V	M1.2 ■ 64 V
M2.1 ■ 67 V	M2.2 ■ 55 V	M2.3 ■ 46 U	M3.1 ■ 41 V	M3.2 ■ 35 V	M3.3 ■ 32 V	M4.1 ■ 30 U	M4.2 ■ 26 U	K1.1 ■ 110 W	K1.2 ■ 81 W	K1.3 ■ 61 W	K2.1 ■ 98 V	K2.2 ■ 80 V	K2.3 ■ 64 V
K3.1 ■ 87 V	K3.2 ■ 67 V	K3.3 ■ 54 V	K4.1 ■ 81 V	K4.2 ■ 61 V	K4.3 ■ 45 V	K4.4 ■ 38 V	K4.5 ■ 32 V	K5.1 ■ 91 V	K5.2 ■ 69 V	K5.3 ■ 53 V	N1.1 ■ 250 W	N1.2 ■ 188 W	N1.3 ■ 125 W
N2.1 ■ 308 V	N2.2 ■ 277 V	N2.3 ■ 200 V	N3.1 ■ 373 W	N3.2 ■ 220 W	N3.3 ■ 110 W	S1.1 ■ 55 V	S1.2 ■ 45 V	S1.3 ■ 40 U	H1.1 ■ 56 U	H2.1 ■ 33 U	H2.2 ■ 30 U	H3.1 ■ 37 U	H3.2 ■ 30 U

DCON MS tolérance h6.

Produit	DC	DC	DC	LCF	OAL	LS	DCON MS
	(inch)	(mm)	(inch)	(mm)	(mm)	(mm)	(mm)
R4573.0	—	3.00	0.1181	20.0	62.0	36.0	6.00
R4573.1	—	3.10	0.1220	20.0	62.0	36.0	6.00
R4571/8	1/8	3.18	0.1250	20.0	62.0	36.0	6.00
R4573.2	—	3.20	0.1260	20.0	62.0	36.0	6.00
R457N30	N30	3.26	0.1283	20.0	62.0	36.0	6.00
R4573.3	—	3.30	0.1299	20.0	62.0	36.0	6.00
R4573.4	—	3.40	0.1339	20.0	62.0	36.0	6.00
R457N29	N29	3.45	0.1360	20.0	62.0	36.0	6.00
R4573.5	—	3.50	0.1378	20.0	62.0	36.0	6.00
R457N28	N28	3.57	0.1406	20.0	62.0	36.0	6.00
R4579/64	9/64	3.57	0.1406	20.0	62.0	36.0	6.00
R4573.6	—	3.60	0.1417	20.0	62.0	36.0	6.00
R457N27	N27	3.66	0.1441	20.0	62.0	36.0	6.00
R4573.7	—	3.70	0.1457	20.0	62.0	36.0	6.00
R457N26	N26	3.73	0.1469	24.0	66.0	36.0	6.00
R457N25	N25	3.80	0.1496	24.0	66.0	36.0	6.00
R4573.8	—	3.80	0.1496	24.0	66.0	36.0	6.00
R457N24	N24	3.86	0.1520	24.0	66.0	36.0	6.00
R4573.9	—	3.90	0.1535	24.0	66.0	36.0	6.00
R457N23	N23	3.91	0.1539	24.0	66.0	36.0	6.00
R4575/32	5/32	3.97	0.1563	24.0	66.0	36.0	6.00
R457N22	N22	3.99	0.1571	24.0	66.0	36.0	6.00
R4574.0	—	4.00	0.1575	24.0	66.0	36.0	6.00
R457N21	N21	4.04	0.1591	24.0	66.0	36.0	6.00
R4574.05	—	4.05	0.1594	24.0	66.0	36.0	6.00



Produit	DC	DC	DC	LCF	OAL	LS	DCON MS
	(inch)	(mm)	(inch)	(mm)	(mm)	(mm)	(mm)
R457N20	N20	4.09	0.1610	24.0	66.0	36.0	6.00
R4574.1	–	4.10	0.1614	24.0	66.0	36.0	6.00
R4574.2	–	4.20	0.1654	24.0	66.0	36.0	6.00
R457N19	N19	4.22	0.1661	24.0	66.0	36.0	6.00
R4574.3	–	4.30	0.1693	24.0	66.0	36.0	6.00
R457N18	N18	4.31	0.1697	24.0	66.0	36.0	6.00
R45711/64	11/64	4.37	0.1719	24.0	66.0	36.0	6.00
R457N17	N17	4.39	0.1728	24.0	66.0	36.0	6.00
R4574.4	–	4.40	0.1732	24.0	66.0	36.0	6.00
R4574.5	–	4.50	0.1772	24.0	66.0	36.0	6.00
R457N16	N16	4.50	0.1772	24.0	66.0	36.0	6.00
R457N15	N15	4.57	0.1799	24.0	66.0	36.0	6.00
R4574.6	–	4.60	0.1811	24.0	66.0	36.0	6.00
R457N14	N14	4.62	0.1819	24.0	66.0	36.0	6.00
R457N13	N13	4.70	0.1850	24.0	66.0	36.0	6.00
R4574.7	–	4.70	0.1850	24.0	66.0	36.0	6.00
R4573/16	3/16	4.76	0.1875	28.0	66.0	36.0	6.00
R4574.8	–	4.80	0.1890	28.0	66.0	36.0	6.00
R457N12	N12	4.80	0.1890	28.0	66.0	36.0	6.00
R457N11	N11	4.85	0.1909	28.0	66.0	36.0	6.00
R4574.9	–	4.90	0.1929	28.0	66.0	36.0	6.00
R457N10	N10	4.92	0.1937	28.0	66.0	36.0	6.00
R457N9	N9	4.98	0.1961	28.0	66.0	36.0	6.00
R4575.0	–	5.00	0.1969	28.0	66.0	36.0	6.00
R4575.05	–	5.05	0.1988	28.0	66.0	36.0	6.00
R457N8	N8	5.06	0.1992	28.0	66.0	36.0	6.00
R4575.1	–	5.10	0.2008	28.0	66.0	36.0	6.00
R457N7	N7	5.11	0.2010	28.0	66.0	36.0	6.00
R45713/64	13/64	5.16	0.2031	28.0	66.0	36.0	6.00
R457N6	N6	5.18	0.2039	28.0	66.0	36.0	6.00
R4575.2	–	5.20	0.2047	28.0	66.0	36.0	6.00
R457N5	N5	5.22	0.2055	28.0	66.0	36.0	6.00
R4575.3	–	5.30	0.2087	28.0	66.0	36.0	6.00
R457N4	N4	5.31	0.2091	28.0	66.0	36.0	6.00
R4575.4	–	5.40	0.2126	28.0	66.0	36.0	6.00
R457N3	N3	5.41	0.2130	28.0	66.0	36.0	6.00
R4575.5	–	5.50	0.2165	28.0	66.0	36.0	6.00
R4577/32	7/32	5.56	0.2188	28.0	66.0	36.0	6.00
R4575.6	–	5.60	0.2205	28.0	66.0	36.0	6.00
R457N2	N2	5.61	0.2209	28.0	66.0	36.0	6.00
R4575.7	–	5.70	0.2244	28.0	66.0	36.0	6.00
R457N1	N1	5.79	0.2280	28.0	66.0	36.0	6.00
R4575.8	–	5.80	0.2283	28.0	66.0	36.0	6.00
R4575.9	–	5.90	0.2323	28.0	66.0	36.0	6.00
R457A	A	5.94	0.2339	28.0	66.0	36.0	6.00
R45715/64	15/64	5.95	0.2344	28.0	66.0	36.0	6.00
R4576.0	–	6.00	0.2362	28.0	66.0	36.0	6.00
R457B	B	6.05	0.2380	34.0	79.0	36.0	8.00
R4576.05	–	6.05	0.2382	34.0	79.0	36.0	8.00
R4576.1	–	6.10	0.2402	34.0	79.0	36.0	8.00
R457C	C	6.15	0.2421	34.0	79.0	36.0	8.00
R4576.2	–	6.20	0.2441	34.0	79.0	36.0	8.00
R457D	D	6.25	0.2461	34.0	79.0	36.0	8.00
R4576.3	–	6.30	0.2480	34.0	79.0	36.0	8.00
R4571/4	1/4	6.35	0.2500	34.0	79.0	36.0	8.00
R457E	E	6.35	0.2500	34.0	79.0	36.0	8.00
R4576.4	–	6.40	0.2520	34.0	79.0	36.0	8.00
R4576.5	–	6.50	0.2559	34.0	79.0	36.0	8.00
R457F	F	6.53	0.2571	34.0	79.0	36.0	8.00
R4576.6	–	6.60	0.2598	34.0	79.0	36.0	8.00
R457G	G	6.63	0.2610	34.0	79.0	36.0	8.00
R4576.7	–	6.70	0.2638	34.0	79.0	36.0	8.00
R45717/64	17/64	6.75	0.2656	34.0	79.0	36.0	8.00
R457H	H	6.76	0.2661	34.0	79.0	36.0	8.00
R4576.8	–	6.80	0.2677	34.0	79.0	36.0	8.00



Produit	DC	DC	DC	LCF	OAL	LS	DCON MS
	(inch)	(mm)	(inch)	(mm)	(mm)	(mm)	(mm)
R4576.9	—	6.90	0.2717	34.0	79.0	36.0	8.00
R457I	I	6.91	0.2720	34.0	79.0	36.0	8.00
R4577.0	—	7.00	0.2756	34.0	79.0	36.0	8.00
R457J	J	7.04	0.2772	41.0	79.0	36.0	8.00
R4577.1	—	7.10	0.2795	41.0	79.0	36.0	8.00
R457K	K	7.14	0.2811	41.0	79.0	36.0	8.00
R4579/32	9/32	7.14	0.2813	41.0	79.0	36.0	8.00
R4577.2	—	7.20	0.2835	41.0	79.0	36.0	8.00
R4577.3	—	7.30	0.2874	41.0	79.0	36.0	8.00
R457L	L	7.37	0.2902	41.0	79.0	36.0	8.00
R4577.4	—	7.40	0.2913	41.0	79.0	36.0	8.00
R457M	M	7.49	0.2949	41.0	79.0	36.0	8.00
R4577.5	—	7.50	0.2953	41.0	79.0	36.0	8.00
R45719/64	19/64	7.54	0.2969	41.0	79.0	36.0	8.00
R4577.6	—	7.60	0.2992	41.0	79.0	36.0	8.00
R457N	N	7.67	0.3020	41.0	79.0	36.0	8.00
R4577.7	—	7.70	0.3031	41.0	79.0	36.0	8.00
R4577.8	—	7.80	0.3071	41.0	79.0	36.0	8.00
R4577.9	—	7.90	0.3110	41.0	79.0	36.0	8.00
R4575/16	5/16	7.94	0.3125	41.0	79.0	36.0	8.00
R4578.0	—	8.00	0.3150	41.0	79.0	36.0	8.00
R457O	O	8.03	0.3161	47.0	89.0	40.0	10.00
R4578.05	—	8.05	0.3169	47.0	89.0	40.0	10.00
R4578.1	—	8.10	0.3189	47.0	89.0	40.0	10.00
R4578.2	—	8.20	0.3228	47.0	89.0	40.0	10.00
R457P	P	8.20	0.3228	47.0	89.0	40.0	10.00
R4578.3	—	8.30	0.3268	47.0	89.0	40.0	10.00
R45721/64	21/64	8.33	0.3281	47.0	89.0	40.0	10.00
R4578.4	—	8.40	0.3307	47.0	89.0	40.0	10.00
R457Q	Q	8.43	0.3319	47.0	89.0	40.0	10.00
R4578.5	—	8.50	0.3346	47.0	89.0	40.0	10.00
R4578.6	—	8.60	0.3386	47.0	89.0	40.0	10.00
R457R	R	8.61	0.3390	47.0	89.0	40.0	10.00
R4578.7	—	8.70	0.3425	47.0	89.0	40.0	10.00
R45711/32	11/32	8.73	0.3438	47.0	89.0	40.0	10.00
R4578.8	—	8.80	0.3465	47.0	89.0	40.0	10.00
R457S	S	8.84	0.3480	47.0	89.0	40.0	10.00
R4578.9	—	8.90	0.3504	47.0	89.0	40.0	10.00
R4579.0	—	9.00	0.3543	47.0	89.0	40.0	10.00
R457T	T	9.09	0.3579	47.0	89.0	40.0	10.00
R4579.1	—	9.10	0.3583	47.0	89.0	40.0	10.00
R45723/64	23/64	9.13	0.3594	47.0	89.0	40.0	10.00
R4579.2	—	9.20	0.3622	47.0	89.0	40.0	10.00
R4579.3	—	9.30	0.3661	47.0	89.0	40.0	10.00
R457U	U	9.35	0.3681	47.0	89.0	40.0	10.00
R4579.4	—	9.40	0.3701	47.0	89.0	40.0	10.00
R4579.5	—	9.50	0.3740	47.0	89.0	40.0	10.00
R4573/8	3/8	9.53	0.3750	47.0	89.0	40.0	10.00
R457V	V	9.58	0.3772	47.0	89.0	40.0	10.00
R4579.6	—	9.60	0.3780	47.0	89.0	40.0	10.00
R4579.7	—	9.70	0.3819	47.0	89.0	40.0	10.00
R4579.8	—	9.80	0.3858	47.0	89.0	40.0	10.00
R457W	W	9.80	0.3858	47.0	89.0	40.0	10.00
R4579.9	—	9.90	0.3898	47.0	89.0	40.0	10.00
R45725/64	25/64	9.92	0.3906	47.0	89.0	40.0	10.00
R45710.0	—	10.00	0.3937	47.0	89.0	40.0	10.00
R45710.05	—	10.05	0.3957	55.0	102.0	45.0	12.00
R457X	X	10.08	0.3969	55.0	102.0	45.0	12.00
R45710.1	—	10.10	0.3976	55.0	102.0	45.0	12.00
R45710.2	—	10.20	0.4016	55.0	102.0	45.0	12.00
R457Y	Y	10.26	0.4039	55.0	102.0	45.0	12.00
R45710.3	—	10.30	0.4055	55.0	102.0	45.0	12.00
R45713/32	13/32	10.32	0.4063	55.0	102.0	45.0	12.00
R45710.4	—	10.40	0.4094	55.0	102.0	45.0	12.00
R457Z	Z	10.49	0.4130	55.0	102.0	45.0	12.00



Produit	DC	DC	DC	LCF	OAL	LS	DCON MS
	(inch)	(mm)	(inch)	(mm)	(mm)	(mm)	(mm)
R45710.5	–	10.50	0.4134	55.0	102.0	45.0	12.00
R45710.6	–	10.60	0.4173	55.0	102.0	45.0	12.00
R45727/64	27/64	10.72	0.4219	55.0	102.0	45.0	12.00
R45710.8	–	10.80	0.4252	55.0	102.0	45.0	12.00
R45711.0	–	11.00	0.4331	55.0	102.0	45.0	12.00
R4577/16	7/16	11.11	0.4375	55.0	102.0	45.0	12.00
R45711.2	–	11.20	0.4409	55.0	102.0	45.0	12.00
R45711.3	–	11.30	0.4449	55.0	102.0	45.0	12.00
R45711.4	–	11.40	0.4488	55.0	102.0	45.0	12.00
R45711.5	–	11.50	0.4528	55.0	102.0	45.0	12.00
R45729/64	29/64	11.51	0.4531	55.0	102.0	45.0	12.00
R45711.6	–	11.60	0.4567	55.0	102.0	45.0	12.00
R45711.8	–	11.80	0.4646	55.0	102.0	45.0	12.00
R45715/32	15/32	11.91	0.4688	55.0	102.0	45.0	12.00
R45712.0	–	12.00	0.4724	55.0	102.0	45.0	12.00
R45712.05	–	12.05	0.4744	60.0	107.0	45.0	14.00
R45712.1	–	12.10	0.4764	60.0	107.0	45.0	14.00
R45712.2	–	12.20	0.4803	60.0	107.0	45.0	14.00
R45731/64	31/64	12.30	0.4844	60.0	107.0	45.0	14.00
R45712.5	–	12.50	0.4921	60.0	107.0	45.0	14.00
R45712.7	–	12.70	0.5000	60.0	107.0	45.0	14.00
R4571/2	1/2	12.70	0.5000	60.0	107.0	45.0	14.00
R45712.8	–	12.80	0.5039	60.0	107.0	45.0	14.00
R45713.0	–	13.00	0.5118	60.0	107.0	45.0	14.00
R45733/64	33/64	13.10	0.5156	60.0	107.0	45.0	14.00
R45713.3	–	13.30	0.5236	60.0	107.0	45.0	14.00
R45717/32	17/32	13.49	0.5313	60.0	107.0	45.0	14.00
R45713.5	–	13.50	0.5315	60.0	107.0	45.0	14.00
R45713.8	–	13.80	0.5433	60.0	107.0	45.0	14.00
R45735/64	35/64	13.89	0.5469	60.0	107.0	45.0	14.00
R45714.0	–	14.00	0.5512	60.0	107.0	45.0	14.00
R45714.25	–	14.25	0.5610	65.0	115.0	48.0	16.00
R4579/16	9/16	14.29	0.5625	65.0	115.0	48.0	16.00
R45714.5	–	14.50	0.5709	65.0	115.0	48.0	16.00
R45737/64	37/64	14.68	0.5781	65.0	115.0	48.0	16.00
R45714.8	–	14.80	0.5827	65.0	115.0	48.0	16.00
R45715.0	–	15.00	0.5906	65.0	115.0	48.0	16.00
R45719/32	19/32	15.08	0.5938	65.0	115.0	48.0	16.00
R45715.1	–	15.10	0.5945	65.0	115.0	48.0	16.00
R45715.3	–	15.30	0.6024	65.0	115.0	48.0	16.00
R45739/64	39/64	15.48	0.6094	65.0	115.0	48.0	16.00
R45715.5	–	15.50	0.6102	65.0	115.0	48.0	16.00
R45715.8	–	15.80	0.6220	65.0	115.0	48.0	16.00
R4575/8	5/8	15.88	0.6250	65.0	115.0	48.0	16.00
R45716.0	–	16.00	0.6299	65.0	115.0	48.0	16.00
R45741/64	41/64	16.27	0.6406	73.0	123.0	48.0	18.00
R45716.5	–	16.50	0.6496	73.0	123.0	48.0	18.00
R45721/32	21/32	16.67	0.6563	73.0	123.0	48.0	18.00
R45717.0	–	17.00	0.6693	73.0	123.0	48.0	18.00
R45743/64	43/64	17.07	0.6720	73.0	123.0	48.0	18.00
R45711/16	11/16	17.46	0.6874	73.0	123.0	48.0	18.00
R45717.5	–	17.50	0.6890	73.0	123.0	48.0	18.00
R45745/64	45/64	17.86	0.7031	73.0	123.0	48.0	18.00
R45718.0	–	18.00	0.7087	73.0	123.0	48.0	18.00
R45723/32	23/32	18.26	0.7189	79.0	131.0	50.0	20.00
R45718.5	–	18.50	0.7283	79.0	131.0	50.0	20.00
R45747/64	47/64	18.65	0.7343	79.0	131.0	50.0	20.00
R45718.8	–	18.80	0.7402	79.0	131.0	50.0	20.00
R45719.0	–	19.00	0.7480	79.0	131.0	50.0	20.00
R4573/4	3/4	19.05	0.7500	79.0	131.0	50.0	20.00
R45719.5	–	19.50	0.7677	79.0	131.0	50.0	20.00
R45719.8	–	19.80	0.7795	79.0	131.0	50.0	20.00
R45720.0	–	20.00	0.7874	79.0	131.0	50.0	20.00



R454



Foret carbure monobloc FORCE X longueur 5xD, revêtement TiAlN

Foret haute performance multi-applications capable de produire des trous précis de haute qualité à des vitesses et des avances élevées (tolérance de trou H9). Pointe auto-centrante à 140° avec 4 facettes et une conception de goujure CTW pour un débit copeaux optimum. Le revêtement TiAlN augmente la dureté en surface et améliore la durée de vie de l'outil.

FORCE X

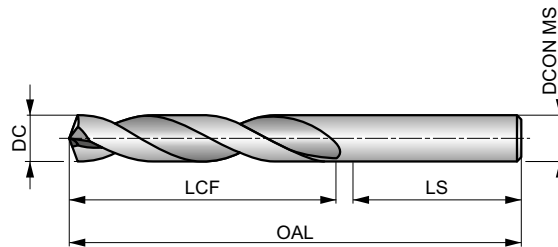

HM	DIN 6537L	5xD
140°	TiAlN	DIN 6535HA
CTW	DC m7	

Adéquation du groupe de matériaux de la pièce, valeurs de départ pour la vitesse de coupe (m/min) et code Alpha d'avance. Les tableaux d'avances par tour se trouvent à partir de la page 65.

P1.1 ■ 134 V	P1.2 ■ 150 V	P1.3 ■ 155 V	P2.1 ■ 115 V	P2.2 ■ 101 V	P2.3 ■ 89 V	P3.1 ■ 100 V	P3.2 ■ 80 V	P3.3 ■ 68 V	P4.1 ■ 59 V	P4.2 ■ 50 V	P4.3 ■ 41 U	M1.1 ■ 56 U	M1.2 ■ 48 U
M2.1 ■ 50 U	M2.2 ■ 41 U	M2.3 ■ 35 T	M3.1 ■ 31 T	M3.2 ■ 26 T	M3.3 ■ 24 T	M4.1 ■ 23 T	M4.2 ■ 20 T	K1.1 ■ 83 W	K1.2 ■ 61 W	K1.3 ■ 46 W	K2.1 ■ 74 V	K2.2 ■ 60 V	K2.3 ■ 48 V
K3.1 ■ 65 V	K3.2 ■ 50 V	K3.3 ■ 41 V	K4.1 ■ 61 V	K4.2 ■ 46 V	K4.3 ■ 34 V	K4.4 ■ 29 V	K4.5 ■ 24 V	K5.1 ■ 68 V	K5.2 ■ 52 V	K5.3 ■ 40 V	N1.1 ■ 188 W	N1.2 ■ 141 W	N1.3 ■ 94 W
N2.1 ■ 231 V	N2.2 ■ 208 V	N2.3 ■ 150 V	N3.1 ■ 280 V	N3.2 ■ 165 V	N3.3 ■ 83 V	S1.1 ■ 41 U	S1.2 ■ 34 U	S1.3 ■ 30 T	H1.1 ■ 42 U	H2.1 ■ 25 U	H2.2 ■ 23 U	H3.1 ■ 28 U	H3.2 ■ 23 U

DCON MS tolérance h6.

Produit	DC	DC	DC	LCF	OAL	LS	DCON MS
	(inch)	(mm)	(inch)	(mm)	(mm)	(mm)	(mm)
R4543.0	–	3.00	0.1181	28.0	66.0	36.0	6.00
R4543.1	–	3.10	0.1220	28.0	66.0	36.0	6.00
R4541/8	1/8	3.18	0.1250	28.0	66.0	36.0	6.00
R4543.2	–	3.20	0.1260	28.0	66.0	36.0	6.00
R454N30	N30	3.26	0.1283	28.0	66.0	36.0	6.00
R4543.3	–	3.30	0.1299	28.0	66.0	36.0	6.00
R4543.4	–	3.40	0.1339	28.0	66.0	36.0	6.00
R454N29	N29	3.45	0.1360	28.0	66.0	36.0	6.00
R4543.5	–	3.50	0.1378	28.0	66.0	36.0	6.00
R454N28	N28	3.57	0.1406	28.0	66.0	36.0	6.00
R4549/64	9/64	3.57	0.1406	28.0	66.0	36.0	6.00
R4543.6	–	3.60	0.1417	28.0	66.0	36.0	6.00
R454N27	N27	3.66	0.1441	28.0	66.0	36.0	6.00
R4543.7	–	3.70	0.1457	28.0	66.0	36.0	6.00
R454N26	N26	3.73	0.1469	36.0	74.0	36.0	6.00
R454N25	N25	3.80	0.1496	36.0	74.0	36.0	6.00
R4543.8	–	3.80	0.1496	36.0	74.0	36.0	6.00
R454N24	N24	3.86	0.1520	36.0	74.0	36.0	6.00
R4543.9	–	3.90	0.1535	36.0	74.0	36.0	6.00
R454N23	N23	3.91	0.1539	36.0	74.0	36.0	6.00
R4545/32	5/32	3.97	0.1563	36.0	74.0	36.0	6.00
R454N22	N22	3.99	0.1571	36.0	74.0	36.0	6.00
R4544.0	–	4.00	0.1575	36.0	74.0	36.0	6.00
R454N21	N21	4.04	0.1591	36.0	74.0	36.0	6.00
R454N20	N20	4.09	0.1610	36.0	74.0	36.0	6.00



Produit	DC	DC	DC	LCF	OAL	LS	DCON MS
	(inch)	(mm)	(inch)	(mm)	(mm)	(mm)	(mm)
R4544.1	–	4.10	0.1614	36.0	74.0	36.0	6.00
R4544.2	–	4.20	0.1654	36.0	74.0	36.0	6.00
R454N19	N19	4.22	0.1661	36.0	74.0	36.0	6.00
R4544.3	–	4.30	0.1693	36.0	74.0	36.0	6.00
R454N18	N18	4.31	0.1697	36.0	74.0	36.0	6.00
R45411/64	11/64	4.37	0.1719	36.0	74.0	36.0	6.00
R454N17	N17	4.39	0.1728	36.0	74.0	36.0	6.00
R4544.4	–	4.40	0.1732	36.0	74.0	36.0	6.00
R4544.5	–	4.50	0.1772	36.0	74.0	36.0	6.00
R454N16	N16	4.50	0.1772	36.0	74.0	36.0	6.00
R454N15	N15	4.57	0.1799	36.0	74.0	36.0	6.00
R4544.6	–	4.60	0.1811	36.0	74.0	36.0	6.00
R454N14	N14	4.62	0.1819	36.0	74.0	36.0	6.00
R454N13	N13	4.70	0.1850	36.0	74.0	36.0	6.00
R4544.7	–	4.70	0.1850	36.0	74.0	36.0	6.00
R4543/16	3/16	4.76	0.1875	44.0	82.0	36.0	6.00
R454N12	N12	4.80	0.1890	44.0	82.0	36.0	6.00
R4544.8	–	4.80	0.1890	44.0	82.0	36.0	6.00
R454N11	N11	4.85	0.1909	44.0	82.0	36.0	6.00
R4544.9	–	4.90	0.1929	44.0	82.0	36.0	6.00
R454N10	N10	4.92	0.1937	44.0	82.0	36.0	6.00
R454N9	N9	4.98	0.1961	44.0	82.0	36.0	6.00
R4545.0	–	5.00	0.1969	44.0	82.0	36.0	6.00
R454N8	N8	5.06	0.1992	44.0	82.0	36.0	6.00
R4545.1	–	5.10	0.2008	44.0	82.0	36.0	6.00
R454N7	N7	5.11	0.2010	44.0	82.0	36.0	6.00
R45413/64	13/64	5.16	0.2031	44.0	82.0	36.0	6.00
R454N6	N6	5.18	0.2039	44.0	82.0	36.0	6.00
R4545.2	–	5.20	0.2047	44.0	82.0	36.0	6.00
R454N5	N5	5.22	0.2055	44.0	82.0	36.0	6.00
R454N4	N4	5.31	0.2091	44.0	82.0	36.0	6.00
R454N3	N3	5.41	0.2130	44.0	82.0	36.0	6.00
R4545.5	–	5.50	0.2165	44.0	82.0	36.0	6.00
R4547/32	7/32	5.56	0.2188	44.0	82.0	36.0	6.00
R4545.6	–	5.60	0.2205	44.0	82.0	36.0	6.00
R454N2	N2	5.61	0.2209	44.0	82.0	36.0	6.00
R4545.7	–	5.70	0.2244	44.0	82.0	36.0	6.00
R454N1	N1	5.79	0.2280	44.0	82.0	36.0	6.00
R4545.8	–	5.80	0.2283	44.0	82.0	36.0	6.00
R454A	A	5.94	0.2339	44.0	82.0	36.0	6.00
R45415/64	15/64	5.95	0.2344	44.0	82.0	36.0	6.00
R4546.0	–	6.00	0.2362	44.0	82.0	36.0	6.00
R454B	B	6.05	0.2380	53.0	91.0	36.0	8.00
R4546.1	–	6.10	0.2402	53.0	91.0	36.0	8.00
R454C	C	6.15	0.2421	53.0	91.0	36.0	8.00
R4546.2	–	6.20	0.2441	53.0	91.0	36.0	8.00
R454D	D	6.25	0.2461	53.0	91.0	36.0	8.00
R4546.3	–	6.30	0.2480	53.0	91.0	36.0	8.00
R4541/4	1/4	6.35	0.2500	53.0	91.0	36.0	8.00
R454E	E	6.35	0.2500	53.0	91.0	36.0	8.00
R4546.4	–	6.40	0.2520	53.0	91.0	36.0	8.00
R4546.5	–	6.50	0.2559	53.0	91.0	36.0	8.00
R454F	F	6.53	0.2571	53.0	91.0	36.0	8.00
R4546.6	–	6.60	0.2598	53.0	91.0	36.0	8.00
R454G	G	6.63	0.2610	53.0	91.0	36.0	8.00
R4546.7	–	6.70	0.2638	53.0	91.0	36.0	8.00
R45417/64	17/64	6.75	0.2656	53.0	91.0	36.0	8.00
R454H	H	6.76	0.2661	53.0	91.0	36.0	8.00
R4546.8	–	6.80	0.2677	53.0	91.0	36.0	8.00
R4546.9	–	6.90	0.2717	53.0	91.0	36.0	8.00
R454I	I	6.91	0.2720	53.0	91.0	36.0	8.00
R4547.0	–	7.00	0.2756	53.0	91.0	36.0	8.00



Produit	DC	DC	DC	LCF	OAL	LS	DCON MS
	(inch)	(mm)	(inch)	(mm)	(mm)	(mm)	(mm)
R454J	J	7.04	0.2772	53.0	91.0	36.0	8.00
R4547.1	—	7.10	0.2795	53.0	91.0	36.0	8.00
R454K	K	7.14	0.2811	53.0	91.0	36.0	8.00
R4549/32	9/32	7.14	0.2813	53.0	91.0	36.0	8.00
R4547.3	—	7.30	0.2874	53.0	91.0	36.0	8.00
R454L	L	7.37	0.2902	53.0	91.0	36.0	8.00
R4547.4	—	7.40	0.2913	53.0	91.0	36.0	8.00
R454M	M	7.49	0.2949	53.0	91.0	36.0	8.00
R4547.5	—	7.50	0.2953	53.0	91.0	36.0	8.00
R45419/64	19/64	7.54	0.2969	53.0	91.0	36.0	8.00
R4547.6	—	7.60	0.2992	53.0	91.0	36.0	8.00
R454N	N	7.67	0.3020	53.0	91.0	36.0	8.00
R4547.7	—	7.70	0.3031	53.0	91.0	36.0	8.00
R4547.8	—	7.80	0.3071	53.0	91.0	36.0	8.00
R4547.9	—	7.90	0.3110	53.0	91.0	36.0	8.00
R4545/16	5/16	7.94	0.3125	53.0	91.0	36.0	8.00
R4548.0	—	8.00	0.3150	53.0	91.0	36.0	8.00
R4540	O	8.03	0.3161	61.0	103.0	40.0	10.00
R4548.1	—	8.10	0.3189	61.0	103.0	40.0	10.00
R4548.2	—	8.20	0.3228	61.0	103.0	40.0	10.00
R454P	P	8.20	0.3228	61.0	103.0	40.0	10.00
R45421/64	21/64	8.33	0.3281	61.0	103.0	40.0	10.00
R4548.4	—	8.40	0.3307	61.0	103.0	40.0	10.00
R454Q	Q	8.43	0.3319	61.0	103.0	40.0	10.00
R4548.5	—	8.50	0.3346	61.0	103.0	40.0	10.00
R4548.6	—	8.60	0.3386	61.0	103.0	40.0	10.00
R454R	R	8.61	0.3390	61.0	103.0	40.0	10.00
R4548.7	—	8.70	0.3425	61.0	103.0	40.0	10.00
R45411/32	11/32	8.73	0.3438	61.0	103.0	40.0	10.00
R4548.8	—	8.80	0.3465	61.0	103.0	40.0	10.00
R454S	S	8.84	0.3480	61.0	103.0	40.0	10.00
R4548.9	—	8.90	0.3504	61.0	103.0	40.0	10.00
R4549.0	—	9.00	0.3543	61.0	103.0	40.0	10.00
R454T	T	9.09	0.3579	61.0	103.0	40.0	10.00
R4549.1	—	9.10	0.3583	61.0	103.0	40.0	10.00
R45423/64	23/64	9.13	0.3594	61.0	103.0	40.0	10.00
R4549.3	—	9.30	0.3661	61.0	103.0	40.0	10.00
R454U	U	9.35	0.3681	61.0	103.0	40.0	10.00
R4549.4	—	9.40	0.3701	61.0	103.0	40.0	10.00
R4549.5	—	9.50	0.3740	61.0	103.0	40.0	10.00
R4543/8	3/8	9.53	0.3750	61.0	103.0	40.0	10.00
R454V	V	9.58	0.3772	61.0	103.0	40.0	10.00
R4549.6	—	9.60	0.3780	61.0	103.0	40.0	10.00
R4549.7	—	9.70	0.3819	61.0	103.0	40.0	10.00
R4549.8	—	9.80	0.3858	61.0	103.0	40.0	10.00
R4549.9	—	9.90	0.3898	61.0	103.0	40.0	10.00
R454W	W	9.80	0.3858	61.0	103.0	40.0	10.00
R45425/64	25/64	9.92	0.3906	61.0	103.0	40.0	10.00
R45410.0	—	10.00	0.3937	61.0	103.0	40.0	10.00
R454X	X	10.08	0.3969	70.0	118.0	45.0	12.00
R45410.1	—	10.10	0.3976	70.0	118.0	45.0	12.00
R45410.2	—	10.20	0.4016	70.0	118.0	45.0	12.00
R454Y	Y	10.26	0.4039	70.0	118.0	45.0	12.00
R45410.3	—	10.30	0.4055	70.0	118.0	45.0	12.00
R45413/32	13/32	10.32	0.4063	70.0	118.0	45.0	12.00
R45410.4	—	10.40	0.4094	70.0	118.0	45.0	12.00
R454Z	Z	10.49	0.4130	70.0	118.0	45.0	12.00
R45410.5	—	10.50	0.4134	70.0	118.0	45.0	12.00
R45410.6	—	10.60	0.4173	70.0	118.0	45.0	12.00
R45427/64	27/64	10.72	0.4219	70.0	118.0	45.0	12.00
R45411.0	—	11.00	0.4331	70.0	118.0	45.0	12.00
R4547/16	7/16	11.11	0.4375	70.0	118.0	45.0	12.00



Produit	DC	DC	DC	LCF	OAL	LS	DCON MS
	(inch)	(mm)	(inch)	(mm)	(mm)	(mm)	(mm)
R45411.2	–	11.20	0.4409	70.0	118.0	45.0	12.00
R45411.4	–	11.40	0.4488	70.0	118.0	45.0	12.00
R45411.5	–	11.50	0.4528	70.0	118.0	45.0	12.00
R45429/64	29/64	11.51	0.4531	70.0	118.0	45.0	12.00
R45411.6	–	11.60	0.4567	70.0	118.0	45.0	12.00
R45411.8	–	11.80	0.4646	70.0	118.0	45.0	12.00
R45415/32	15/32	11.91	0.4688	70.0	118.0	45.0	12.00
R45412.0	–	12.00	0.4724	70.0	118.0	45.0	12.00
R45412.1	–	12.10	0.4764	76.0	124.0	45.0	14.00
R45412.2	–	12.20	0.4803	76.0	124.0	45.0	14.00
R45431/64	31/64	12.30	0.4844	76.0	124.0	45.0	14.00
R45412.5	–	12.50	0.4921	76.0	124.0	45.0	14.00
R45412.7	–	12.70	0.5000	76.0	124.0	45.0	14.00
R4541/2	1/2	12.70	0.5000	76.0	124.0	45.0	14.00
R45412.8	–	12.80	0.5039	76.0	124.0	45.0	14.00
R45413.0	–	13.00	0.5118	76.0	124.0	45.0	14.00
R45433/64	33/64	13.10	0.5156	76.0	124.0	45.0	14.00
R45417/32	17/32	13.49	0.5313	76.0	124.0	45.0	14.00
R45413.5	–	13.50	0.5315	76.0	124.0	45.0	14.00
R45413.8	–	13.80	0.5433	76.0	124.0	45.0	14.00
R45435/64	35/64	13.89	0.5469	76.0	124.0	45.0	14.00
R45414.0	–	14.00	0.5512	76.0	124.0	45.0	14.00
R45414.25	–	14.25	0.5610	82.0	133.0	48.0	16.00
R4549/16	9/16	14.29	0.5625	82.0	133.0	48.0	16.00
R45414.5	–	14.50	0.5709	82.0	133.0	48.0	16.00
R45437/64	37/64	14.68	0.5781	82.0	133.0	48.0	16.00
R45414.8	–	14.80	0.5827	82.0	133.0	48.0	16.00
R45415.0	–	15.00	0.5906	82.0	133.0	48.0	16.00
R45419/32	19/32	15.08	0.5938	82.0	133.0	48.0	16.00
R45415.1	–	15.10	0.5945	82.0	133.0	48.0	16.00
R45439/64	39/64	15.48	0.6094	82.0	133.0	48.0	16.00
R45415.5	–	15.50	0.6102	82.0	133.0	48.0	16.00
R45415.8	–	15.80	0.6220	82.0	133.0	48.0	16.00
R4545/8	5/8	15.88	0.6250	82.0	133.0	48.0	16.00
R45416.0	–	16.00	0.6299	82.0	133.0	48.0	16.00
R45441/64	41/64	16.27	0.6406	91.0	143.0	48.0	18.00
R45416.5	–	16.50	0.6496	91.0	143.0	48.0	18.00
R45421/32	21/32	16.67	0.6563	91.0	143.0	48.0	18.00
R45417.0	–	17.00	0.6693	91.0	143.0	48.0	18.00
R45443/64	43/64	17.07	0.6720	91.0	143.0	48.0	18.00
R45411/16	11/16	17.46	0.6874	91.0	143.0	48.0	18.00
R45417.5	–	17.50	0.6890	91.0	143.0	48.0	18.00
R45417.8	–	17.80	0.7008	91.0	143.0	48.0	18.00
R45445/64	45/64	17.86	0.7031	91.0	143.0	48.0	18.00
R45418.0	–	18.00	0.7087	91.0	143.0	48.0	18.00
R45423/32	23/32	18.26	0.7189	99.0	153.0	50.0	20.00
R45418.5	–	18.50	0.7283	99.0	153.0	50.0	20.00
R45447/64	47/64	18.65	0.7343	99.0	153.0	50.0	20.00
R45419.0	–	19.00	0.7480	99.0	153.0	50.0	20.00
R4543/4	3/4	19.05	0.7500	99.0	153.0	50.0	20.00
R45419.5	–	19.50	0.7677	99.0	153.0	50.0	20.00
R45419.8	–	19.80	0.7795	99.0	153.0	50.0	20.00
R45420.0	–	20.00	0.7874	99.0	153.0	50.0	20.00



R453



Foret carbure monobloc FORCE X longueur 5xD avec arrosage centralisé, revêtement TiAlN

Foret haute performance multi-applications capable de produire des trous précis de haute qualité à des vitesses et des avances élevées (tolérance de trou H9). Pointe auto-centrante à 140° avec 4 facettes et une conception de goujure CTW pour un débit copeaux optimum. L'arrosage centralisé améliore l'évacuation des copeaux. Le revêtement TiAlN augmente la dureté en surface et améliore la durée de vie de l'outil.

FORCE X

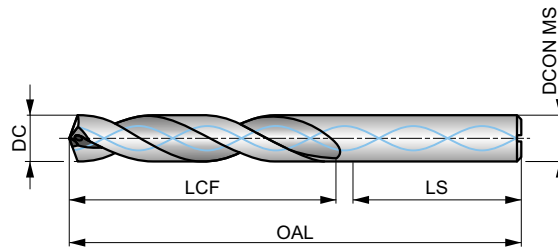

HM	DIN 6537L	5xD
140°	TiAlN	DIN 6535HA
CTW	DC m7	

Adéquation du groupe de matériaux de la pièce, valeurs de départ pour la vitesse de coupe (m/min) et code Alpha d'avance. Les tableaux d'avances par tour se trouvent à partir de la page 65.

P1.1 ■ 170 V	P1.2 ■ 190 V	P1.3 ■ 197 V	P2.1 ■ 145 V	P2.2 ■ 128 V	P2.3 ■ 113 V	P3.1 ■ 126 V	P3.2 ■ 102 V	P3.3 ■ 86 V	P4.1 ■ 75 V	P4.2 ■ 64 V	P4.3 ■ 52 U	M1.1 ■ 71 V	M1.2 ■ 61 V
M2.1 ■ 64 V	M2.2 ■ 52 V	M2.3 ■ 44 U	M3.1 ■ 39 V	M3.2 ■ 33 V	M3.3 ■ 30 V	M4.1 ■ 29 U	M4.2 ■ 25 U	K1.1 ■ 105 W	K1.2 ■ 77 W	K1.3 ■ 58 W	K2.1 ■ 93 V	K2.2 ■ 76 V	K2.3 ■ 61 V
K3.1 ■ 83 V	K3.2 ■ 64 V	K3.3 ■ 51 V	K4.1 ■ 77 V	K4.2 ■ 58 V	K4.3 ■ 43 V	K4.4 ■ 36 V	K4.5 ■ 30 V	K5.1 ■ 86 V	K5.2 ■ 66 V	K5.3 ■ 50 V	N1.1 ■ 238 W	N1.2 ■ 179 W	N1.3 ■ 119 W
N2.1 ■ 293 V	N2.2 ■ 263 V	N2.3 ■ 190 V	N3.1 ■ 354 W	N3.2 ■ 209 W	N3.3 ■ 105 W	S1.1 ■ 52 V	S1.2 ■ 43 V	S1.3 ■ 38 U	H1.1 ■ 53 U	H2.1 ■ 31 U	H2.2 ■ 29 U	H3.1 ■ 35 U	H3.2 ■ 29 U

DCON MS tolérance h6.

Produit	DC	DC	DC	LCF	OAL	LS	DCON MS
	(inch)	(mm)	(inch)	(mm)	(mm)	(mm)	(mm)
R4533.0	—	3.00	0.1181	28.0	66.0	36.0	6.00
R4533.1	—	3.10	0.1220	28.0	66.0	36.0	6.00
R4531/8	1/8	3.18	0.1250	28.0	66.0	36.0	6.00
R4533.2	—	3.20	0.1260	28.0	66.0	36.0	6.00
R453N30	N30	3.26	0.1283	28.0	66.0	36.0	6.00
R4533.3	—	3.30	0.1299	28.0	66.0	36.0	6.00
R4533.4	—	3.40	0.1339	28.0	66.0	36.0	6.00
R453N29	N29	3.45	0.1360	28.0	66.0	36.0	6.00
R4533.5	—	3.50	0.1378	28.0	66.0	36.0	6.00
R453N28	N28	3.57	0.1406	28.0	66.0	36.0	6.00
R4539/64	9/64	3.57	0.1406	28.0	66.0	36.0	6.00
R4533.6	—	3.60	0.1417	28.0	66.0	36.0	6.00
R453N27	N27	3.66	0.1441	28.0	66.0	36.0	6.00
R4533.7	—	3.70	0.1457	28.0	66.0	36.0	6.00
R453N26	N26	3.73	0.1469	36.0	74.0	36.0	6.00
R453N25	N25	3.80	0.1496	36.0	74.0	36.0	6.00
R4533.8	—	3.80	0.1496	36.0	74.0	36.0	6.00
R453N24	N24	3.86	0.1520	36.0	74.0	36.0	6.00
R4533.9	—	3.90	0.1535	36.0	74.0	36.0	6.00
R453N23	N23	3.91	0.1539	36.0	74.0	36.0	6.00
R4535/32	5/32	3.97	0.1563	36.0	74.0	36.0	6.00
R453N22	N22	3.99	0.1571	36.0	74.0	36.0	6.00
R4534.0	—	4.00	0.1575	36.0	74.0	36.0	6.00
R453N21	N21	4.04	0.1591	36.0	74.0	36.0	6.00
R4534.05	—	4.05	0.1594	36.0	74.0	36.0	6.00



Produit	DC	DC	DC	LCF	OAL	LS	DCON MS
	(inch)	(mm)	(inch)	(mm)	(mm)	(mm)	(mm)
R453N20	N20	4.09	0.1610	36.0	74.0	36.0	6.00
R4534.1	–	4.10	0.1614	36.0	74.0	36.0	6.00
R4534.2	–	4.20	0.1654	36.0	74.0	36.0	6.00
R453N19	N19	4.22	0.1661	36.0	74.0	36.0	6.00
R4534.3	–	4.30	0.1693	36.0	74.0	36.0	6.00
R453N18	N18	4.31	0.1697	36.0	74.0	36.0	6.00
R45311/64	11/64	4.37	0.1719	36.0	74.0	36.0	6.00
R453N17	N17	4.39	0.1728	36.0	74.0	36.0	6.00
R4534.4	–	4.40	0.1732	36.0	74.0	36.0	6.00
R4534.5	–	4.50	0.1772	36.0	74.0	36.0	6.00
R453N16	N16	4.50	0.1772	36.0	74.0	36.0	6.00
R453N15	N15	4.57	0.1799	36.0	74.0	36.0	6.00
R4534.6	–	4.60	0.1811	36.0	74.0	36.0	6.00
R453N14	N14	4.62	0.1819	36.0	74.0	36.0	6.00
R453N13	N13	4.70	0.1850	36.0	74.0	36.0	6.00
R4534.7	–	4.70	0.1850	36.0	74.0	36.0	6.00
R4533/16	3/16	4.76	0.1875	44.0	82.0	36.0	6.00
R4534.8	–	4.80	0.1890	44.0	82.0	36.0	6.00
R453N12	N12	4.80	0.1890	44.0	82.0	36.0	6.00
R453N11	N11	4.85	0.1909	44.0	82.0	36.0	6.00
R4534.9	–	4.90	0.1929	44.0	82.0	36.0	6.00
R453N10	N10	4.92	0.1937	44.0	82.0	36.0	6.00
R453N9	N9	4.98	0.1961	44.0	82.0	36.0	6.00
R4535.0	–	5.00	0.1969	44.0	82.0	36.0	6.00
R4535.05	–	5.05	0.1988	44.0	82.0	36.0	6.00
R453N8	N8	5.06	0.1992	44.0	82.0	36.0	6.00
R4535.1	–	5.10	0.2008	44.0	82.0	36.0	6.00
R453N7	N7	5.11	0.2010	44.0	82.0	36.0	6.00
R45313/64	13/64	5.16	0.2031	44.0	82.0	36.0	6.00
R453N6	N6	5.18	0.2039	44.0	82.0	36.0	6.00
R4535.2	–	5.20	0.2047	44.0	82.0	36.0	6.00
R453N5	N5	5.22	0.2055	44.0	82.0	36.0	6.00
R4535.3	–	5.30	0.2087	44.0	82.0	36.0	6.00
R453N4	N4	5.31	0.2091	44.0	82.0	36.0	6.00
R4535.4	–	5.40	0.2126	44.0	82.0	36.0	6.00
R453N3	N3	5.41	0.2130	44.0	82.0	36.0	6.00
R4535.5	–	5.50	0.2165	44.0	82.0	36.0	6.00
R4537/32	7/32	5.56	0.2188	44.0	82.0	36.0	6.00
R4535.6	–	5.60	0.2205	44.0	82.0	36.0	6.00
R453N2	N2	5.61	0.2209	44.0	82.0	36.0	6.00
R4535.7	–	5.70	0.2244	44.0	82.0	36.0	6.00
R453N1	N1	5.79	0.2280	44.0	82.0	36.0	6.00
R4535.8	–	5.80	0.2283	44.0	82.0	36.0	6.00
R4535.9	–	5.90	0.2323	44.0	82.0	36.0	6.00
R453A	A	5.94	0.2339	44.0	82.0	36.0	6.00
R45315/64	15/64	5.95	0.2344	44.0	82.0	36.0	6.00
R4536.0	–	6.00	0.2362	44.0	82.0	36.0	6.00
R453B	B	6.05	0.2380	53.0	91.0	36.0	8.00
R4536.05	–	6.05	0.2382	53.0	91.0	36.0	8.00
R4536.1	–	6.10	0.2402	53.0	91.0	36.0	8.00
R453C	C	6.15	0.2421	53.0	91.0	36.0	8.00
R4536.2	–	6.20	0.2441	53.0	91.0	36.0	8.00
R453D	D	6.25	0.2461	53.0	91.0	36.0	8.00
R4536.3	–	6.30	0.2480	53.0	91.0	36.0	8.00
R4531/4	1/4	6.35	0.2500	53.0	91.0	36.0	8.00
R453E	E	6.35	0.2500	53.0	91.0	36.0	8.00
R4536.4	–	6.40	0.2520	53.0	91.0	36.0	8.00
R4536.5	–	6.50	0.2559	53.0	91.0	36.0	8.00
R453F	F	6.53	0.2571	53.0	91.0	36.0	8.00
R4536.6	–	6.60	0.2598	53.0	91.0	36.0	8.00
R453G	G	6.63	0.2610	53.0	91.0	36.0	8.00
R4536.7	–	6.70	0.2638	53.0	91.0	36.0	8.00
R45317/64	17/64	6.75	0.2656	53.0	91.0	36.0	8.00
R453H	H	6.76	0.2661	53.0	91.0	36.0	8.00
R4536.8	–	6.80	0.2677	53.0	91.0	36.0	8.00



Produit	DC	DC	DC	LCF	OAL	LS	DCON MS
	(inch)	(mm)	(inch)	(mm)	(mm)	(mm)	(mm)
R4536.9	—	6.90	0.2717	53.0	91.0	36.0	8.00
R453I	I	6.91	0.2720	53.0	91.0	36.0	8.00
R4537.0	—	7.00	0.2756	53.0	91.0	36.0	8.00
R453J	J	7.04	0.2772	53.0	91.0	36.0	8.00
R4537.1	—	7.10	0.2795	53.0	91.0	36.0	8.00
R453K	K	7.14	0.2811	53.0	91.0	36.0	8.00
R4539/32	9/32	7.14	0.2813	53.0	91.0	36.0	8.00
R4537.2	—	7.20	0.2835	53.0	91.0	36.0	8.00
R4537.3	—	7.30	0.2874	53.0	91.0	36.0	8.00
R453L	L	7.37	0.2902	53.0	91.0	36.0	8.00
R4537.4	—	7.40	0.2913	53.0	91.0	36.0	8.00
R453M	M	7.49	0.2949	53.0	91.0	36.0	8.00
R4537.5	—	7.50	0.2953	53.0	91.0	36.0	8.00
R45319/64	19/64	7.54	0.2969	53.0	91.0	36.0	8.00
R4537.6	—	7.60	0.2992	53.0	91.0	36.0	8.00
R453N	N	7.67	0.3020	53.0	91.0	36.0	8.00
R4537.7	—	7.70	0.3031	53.0	91.0	36.0	8.00
R4537.8	—	7.80	0.3071	53.0	91.0	36.0	8.00
R4537.9	—	7.90	0.3110	53.0	91.0	36.0	8.00
R4535/16	5/16	7.94	0.3125	53.0	91.0	36.0	8.00
R4538.0	—	8.00	0.3150	53.0	91.0	36.0	8.00
R453O	O	8.03	0.3161	61.0	103.0	40.0	10.00
R4538.05	—	8.05	0.3169	61.0	103.0	40.0	10.00
R4538.1	—	8.10	0.3189	61.0	103.0	40.0	10.00
R4538.2	—	8.20	0.3228	61.0	103.0	40.0	10.00
R453P	P	8.20	0.3228	61.0	103.0	40.0	10.00
R4538.3	—	8.30	0.3268	61.0	103.0	40.0	10.00
R45321/64	21/64	8.33	0.3281	61.0	103.0	40.0	10.00
R4538.4	—	8.40	0.3307	61.0	103.0	40.0	10.00
R453Q	Q	8.43	0.3319	61.0	103.0	40.0	10.00
R4538.5	—	8.50	0.3346	61.0	103.0	40.0	10.00
R4538.6	—	8.60	0.3386	61.0	103.0	40.0	10.00
R453R	R	8.61	0.3390	61.0	103.0	40.0	10.00
R4538.7	—	8.70	0.3425	61.0	103.0	40.0	10.00
R45311/32	11/32	8.73	0.3438	61.0	103.0	40.0	10.00
R4538.8	—	8.80	0.3465	61.0	103.0	40.0	10.00
R453S	S	8.84	0.3480	61.0	103.0	40.0	10.00
R4538.9	—	8.90	0.3504	61.0	103.0	40.0	10.00
R4539.0	—	9.00	0.3543	61.0	103.0	40.0	10.00
R453T	T	9.09	0.3579	61.0	103.0	40.0	10.00
R4539.1	—	9.10	0.3583	61.0	103.0	40.0	10.00
R45323/64	23/64	9.13	0.3594	61.0	103.0	40.0	10.00
R4539.2	—	9.20	0.3622	61.0	103.0	40.0	10.00
R4539.3	—	9.30	0.3661	61.0	103.0	40.0	10.00
R453U	U	9.35	0.3681	61.0	103.0	40.0	10.00
R4539.4	—	9.40	0.3701	61.0	103.0	40.0	10.00
R4539.5	—	9.50	0.3740	61.0	103.0	40.0	10.00
R4533/8	3/8	9.53	0.3750	61.0	103.0	40.0	10.00
R453V	V	9.58	0.3772	61.0	103.0	40.0	10.00
R4539.6	—	9.60	0.3780	61.0	103.0	40.0	10.00
R4539.7	—	9.70	0.3819	61.0	103.0	40.0	10.00
R4539.8	—	9.80	0.3858	61.0	103.0	40.0	10.00
R453W	W	9.80	0.3858	61.0	103.0	40.0	10.00
R4539.9	—	9.90	0.3898	61.0	103.0	40.0	10.00
R45325/64	25/64	9.92	0.3906	61.0	103.0	40.0	10.00
R45310.0	—	10.00	0.3937	61.0	103.0	40.0	10.00
R45310.05	—	10.05	0.3957	70.0	118.0	45.0	12.00
R453X	X	10.08	0.3969	70.0	118.0	45.0	12.00
R45310.1	—	10.10	0.3976	70.0	118.0	45.0	12.00
R45310.2	—	10.20	0.4016	70.0	118.0	45.0	12.00
R453Y	Y	10.26	0.4039	70.0	118.0	45.0	12.00
R45310.3	—	10.30	0.4055	70.0	118.0	45.0	12.00
R45313/32	13/32	10.32	0.4063	70.0	118.0	45.0	12.00
R45310.4	—	10.40	0.4094	70.0	118.0	45.0	12.00
R453Z	Z	10.49	0.4130	70.0	118.0	45.0	12.00



Produit	DC	DC	DC	LCF	OAL	LS	DCON MS
	(inch)	(mm)	(inch)	(mm)	(mm)	(mm)	(mm)
R45310.5	–	10.50	0.4134	70.0	118.0	45.0	12.00
R45310.6	–	10.60	0.4173	70.0	118.0	45.0	12.00
R45327/64	27/64	10.72	0.4219	70.0	118.0	45.0	12.00
R45310.8	–	10.80	0.4252	70.0	118.0	45.0	12.00
R45311.0	–	11.00	0.4331	70.0	118.0	45.0	12.00
R4537/16	7/16	11.11	0.4375	70.0	118.0	45.0	12.00
R45311.2	–	11.20	0.4409	70.0	118.0	45.0	12.00
R45311.3	–	11.30	0.4449	70.0	118.0	45.0	12.00
R45311.4	–	11.40	0.4488	70.0	118.0	45.0	12.00
R45311.5	–	11.50	0.4528	70.0	118.0	45.0	12.00
R45329/64	29/64	11.51	0.4531	70.0	118.0	45.0	12.00
R45311.6	–	11.60	0.4567	70.0	118.0	45.0	12.00
R45311.8	–	11.80	0.4646	70.0	118.0	45.0	12.00
R45315/32	15/32	11.91	0.4688	70.0	118.0	45.0	12.00
R45312.0	–	12.00	0.4724	70.0	118.0	45.0	12.00
R45312.05	–	12.05	0.4744	76.0	124.0	45.0	14.00
R45312.2	–	12.20	0.4803	76.0	124.0	45.0	14.00
R45331/64	31/64	12.30	0.4844	76.0	124.0	45.0	14.00
R45312.5	–	12.50	0.4921	76.0	124.0	45.0	14.00
R45312.7	–	12.70	0.5000	76.0	124.0	45.0	14.00
R4531/2	1/2	12.70	0.5000	76.0	124.0	45.0	14.00
R45312.8	–	12.80	0.5039	76.0	124.0	45.0	14.00
R45313.0	–	13.00	0.5118	76.0	124.0	45.0	14.00
R45333/64	33/64	13.10	0.5156	76.0	124.0	45.0	14.00
R45313.3	–	13.30	0.5236	76.0	124.0	45.0	14.00
R45317/32	17/32	13.49	0.5313	76.0	124.0	45.0	14.00
R45313.5	–	13.50	0.5315	76.0	124.0	45.0	14.00
R45313.8	–	13.80	0.5433	76.0	124.0	45.0	14.00
R45335/64	35/64	13.89	0.5469	76.0	124.0	45.0	14.00
R45314.0	–	14.00	0.5512	76.0	124.0	45.0	14.00
R45314.25	–	14.25	0.5610	82.0	133.0	48.0	16.00
R4539/16	9/16	14.29	0.5625	82.0	133.0	48.0	16.00
R45314.5	–	14.50	0.5709	82.0	133.0	48.0	16.00
R45337/64	37/64	14.68	0.5781	82.0	133.0	48.0	16.00
R45314.8	–	14.80	0.5827	82.0	133.0	48.0	16.00
R45315.0	–	15.00	0.5906	82.0	133.0	48.0	16.00
R45319/32	19/32	15.08	0.5938	82.0	133.0	48.0	16.00
R45315.1	–	15.10	0.5945	82.0	133.0	48.0	16.00
R45315.3	–	15.30	0.6024	82.0	133.0	48.0	16.00
R45339/64	39/64	15.48	0.6094	82.0	133.0	48.0	16.00
R45315.5	–	15.50	0.6102	82.0	133.0	48.0	16.00
R45315.8	–	15.80	0.6220	82.0	133.0	48.0	16.00
R4535/8	5/8	15.88	0.6250	82.0	133.0	48.0	16.00
R45316.0	–	16.00	0.6299	82.0	133.0	48.0	16.00
R45341/64	41/64	16.27	0.6406	91.0	143.0	48.0	18.00
R45316.5	–	16.50	0.6496	91.0	143.0	48.0	18.00
R45321/32	21/32	16.67	0.6563	91.0	143.0	48.0	18.00
R45317.0	–	17.00	0.6693	91.0	143.0	48.0	18.00
R45343/64	43/64	17.07	0.6720	91.0	143.0	48.0	18.00
R45311/16	11/16	17.46	0.6874	91.0	143.0	48.0	18.00
R45317.5	–	17.50	0.6890	91.0	143.0	48.0	18.00
R45317.8	–	17.80	0.7008	91.0	143.0	48.0	18.00
R45345/64	45/64	17.86	0.7031	91.0	143.0	48.0	18.00
R45318.0	–	18.00	0.7087	91.0	143.0	48.0	18.00
R45323/32	23/32	18.26	0.7189	99.0	143.0	48.0	20.00
R45318.5	–	18.50	0.7283	99.0	153.0	50.0	20.00
R45347/64	47/64	18.65	0.7343	99.0	153.0	50.0	20.00
R45319.0	–	19.00	0.7480	99.0	153.0	50.0	20.00
R4533/4	3/4	19.05	0.7500	99.0	153.0	50.0	20.00
R45319.5	–	19.50	0.7677	99.0	153.0	50.0	20.00
R45319.8	–	19.80	0.7795	99.0	153.0	50.0	20.00
R45320.0	–	20.00	0.7874	99.0	153.0	50.0	20.00



R459



Foret carbure monobloc FORCE X longueur 8xD avec arrosage centralisé, revêtement TiAIN

Foret haute performance multi-applications capable de produire des trous précis de haute qualité à des vitesses et des avances élevées (tolérance de trou H9). Pointe auto-centrante à 140° avec 4 facettes et une conception de goujure CTW pour un débit copeaux optimum. L'arrosage centralisé améliore l'évacuation des copeaux. Le revêtement TiAIN augmente la dureté en surface et améliore la durée de vie de l'outil.

FORCE X

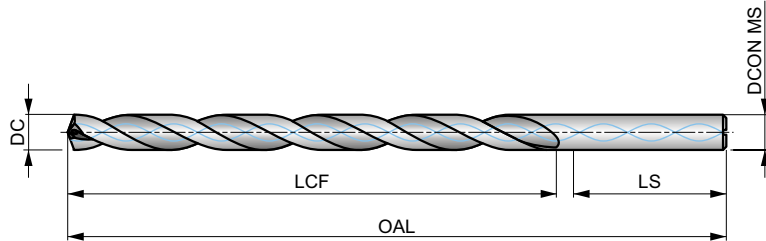

HM	DORMER	8xD
140°	TiAIN	DIN 6535HA
CTW	DC m7	

Adéquation du groupe de matériaux de la pièce, valeurs de départ pour la vitesse de coupe (m/min) et code Alpha d'avance. Les tableaux d'avances par tour se trouvent à partir de la page 65.

P1.1 ■ 143 V	P1.2 ■ 160 V	P1.3 ■ 166 V	P2.1 ■ 122 V	P2.2 ■ 108 U	P2.3 ■ 95 U	P3.1 ■ 106 U	P3.2 ■ 86 U	P3.3 ■ 72 U	P4.1 ■ 63 U	P4.2 ■ 54 U	P4.3 ■ 44 T	M1.1 ■ 60 V	M1.2 ■ 51 V
M2.1 ■ 54 V	M2.2 ■ 44 V	M2.3 ■ 37 U	M3.1 ■ 33 V	M3.2 ■ 28 V	M3.3 ■ 26 V	M4.1 ■ 24 U	M4.2 ■ 21 U	K1.1 ■ 88 W	K1.2 ■ 65 W	K1.3 ■ 49 W	K2.1 ■ 78 V	K2.2 ■ 64 V	K2.3 ■ 51 V
K3.1 ■ 70 V	K3.2 ■ 54 V	K3.3 ■ 43 V	K4.1 ■ 65 V	K4.2 ■ 49 V	K4.3 ■ 36 V	K4.4 ■ 30 V	K4.5 ■ 26 V	K5.1 ■ 73 V	K5.2 ■ 55 V	K5.3 ■ 42 V	N1.1 ■ 200 W	N1.2 ■ 150 W	N1.3 ■ 100 W
N2.1 ■ 246 V	N2.2 ■ 222 V	N2.3 ■ 160 V	N3.1 ■ 298 V	N3.2 ■ 176 V	N3.3 ■ 188 V								

DCON MS tolérance h6.

Produit	DC	DC	DC	LCF	OAL	LS	DCON MS
	(inch)	(mm)	(inch)	(mm)	(mm)	(mm)	(mm)
R4593.0	—	3.00	0.1181	37.0	79.0	36.0	6.00
R4593.1	—	3.10	0.1220	37.0	79.0	36.0	6.00
R4591/8	1/8	3.18	0.1250	37.0	79.0	36.0	6.00
R4593.2	—	3.20	0.1260	37.0	79.0	36.0	6.00
R4593.3	—	3.30	0.1299	37.0	79.0	36.0	6.00
R4593.4	—	3.40	0.1339	37.0	79.0	36.0	6.00
R4593.5	—	3.50	0.1378	37.0	79.0	36.0	6.00
R4599/64	9/64	3.57	0.1406	37.0	79.0	36.0	6.00
R4593.6	—	3.60	0.1417	37.0	79.0	36.0	6.00
R4593.7	—	3.70	0.1457	37.0	79.0	36.0	6.00
R4593.8	—	3.80	0.1496	48.0	90.0	36.0	6.00
R4593.9	—	3.90	0.1535	48.0	90.0	36.0	6.00
R4595/32	5/32	3.97	0.1563	48.0	90.0	36.0	6.00
R4594.0	—	4.00	0.1575	48.0	90.0	36.0	6.00
R4594.1	—	4.10	0.1614	48.0	90.0	36.0	6.00
R4594.2	—	4.20	0.1654	48.0	90.0	36.0	6.00
R4594.3	—	4.30	0.1693	48.0	90.0	36.0	6.00
R45911/64	11/64	4.37	0.1719	48.0	90.0	36.0	6.00
R4594.4	—	4.40	0.1732	48.0	90.0	36.0	6.00
R4594.5	—	4.50	0.1772	48.0	90.0	36.0	6.00
R4594.6	—	4.60	0.1811	48.0	90.0	36.0	6.00
R4594.7	—	4.70	0.1850	62.0	104.0	36.0	6.00
R4593/16	3/16	4.76	0.1875	62.0	104.0	36.0	6.00
R4594.8	—	4.80	0.1890	62.0	104.0	36.0	6.00
R4594.9	—	4.90	0.1929	62.0	104.0	36.0	6.00



Produit	DC	DC	DC	LCF	OAL	LS	DCON MS
	(inch)	(mm)	(inch)	(mm)	(mm)	(mm)	(mm)
R4595.0	–	5.00	0.1969	62.0	104.0	36.0	6.00
R4595.1	–	5.10	0.2008	62.0	104.0	36.0	6.00
R45913/64	13/64	5.16	0.2031	62.0	104.0	36.0	6.00
R4595.2	–	5.20	0.2047	62.0	104.0	36.0	6.00
R4595.3	–	5.30	0.2087	62.0	104.0	36.0	6.00
R4595.4	–	5.40	0.2126	62.0	104.0	36.0	6.00
R4595.5	–	5.50	0.2165	62.0	104.0	36.0	6.00
R4597/32	7/32	5.56	0.2188	62.0	104.0	36.0	6.00
R4595.6	–	5.60	0.2205	62.0	104.0	36.0	6.00
R4595.7	–	5.70	0.2244	62.0	104.0	36.0	6.00
R4595.8	–	5.80	0.2283	62.0	104.0	36.0	6.00
R4595.9	–	5.90	0.2323	62.0	104.0	36.0	6.00
R45915/64	15/64	5.95	0.2344	62.0	104.0	36.0	6.00
R4596.0	–	6.00	0.2362	62.0	104.0	36.0	6.00
R4596.1	–	6.10	0.2402	84.0	126.0	36.0	8.00
R4596.2	–	6.20	0.2441	84.0	126.0	36.0	8.00
R4596.3	–	6.30	0.2480	84.0	126.0	36.0	8.00
R4591/4	1/4	6.35	0.2500	84.0	126.0	36.0	8.00
R4596.4	–	6.40	0.2520	84.0	126.0	36.0	8.00
R4596.5	–	6.50	0.2559	84.0	126.0	36.0	8.00
R4596.6	–	6.60	0.2598	84.0	126.0	36.0	8.00
R4596.7	–	6.70	0.2638	84.0	126.0	36.0	8.00
R45917/64	17/64	6.75	0.2656	84.0	126.0	36.0	8.00
R4596.8	–	6.80	0.2677	84.0	126.0	36.0	8.00
R4596.9	–	6.90	0.2717	84.0	126.0	36.0	8.00
R4597.0	–	7.00	0.2756	84.0	126.0	36.0	8.00
R4597.1	–	7.10	0.2795	84.0	126.0	36.0	8.00
R4599/32	9/32	7.14	0.2813	84.0	126.0	36.0	8.00
R4597.2	–	7.20	0.2835	84.0	126.0	36.0	8.00
R4597.3	–	7.30	0.2874	84.0	126.0	36.0	8.00
R4597.4	–	7.40	0.2913	84.0	126.0	36.0	8.00
R4597.5	–	7.50	0.2953	84.0	126.0	36.0	8.00
R45919/64	19/64	7.54	0.2969	84.0	126.0	36.0	8.00
R4597.6	–	7.60	0.2992	84.0	126.0	36.0	8.00
R4597.7	–	7.70	0.3031	84.0	126.0	36.0	8.00
R4597.8	–	7.80	0.3071	84.0	126.0	36.0	8.00
R4597.9	–	7.90	0.3110	84.0	126.0	36.0	8.00
R4595/16	5/16	7.94	0.3125	84.0	126.0	36.0	8.00
R4598.0	–	8.00	0.3150	84.0	126.0	36.0	8.00
R4598.1	–	8.10	0.3189	106.0	152.0	40.0	10.00
R4598.2	–	8.20	0.3228	106.0	152.0	40.0	10.00
R4598.3	–	8.30	0.3268	106.0	152.0	40.0	10.00
R45921/64	21/64	8.33	0.3281	106.0	152.0	40.0	10.00
R4598.4	–	8.40	0.3307	106.0	152.0	40.0	10.00
R4598.5	–	8.50	0.3346	106.0	152.0	40.0	10.00
R4598.6	–	8.60	0.3386	106.0	152.0	40.0	10.00
R4598.7	–	8.70	0.3425	106.0	152.0	40.0	10.00
R45911/32	11/32	8.73	0.3438	106.0	152.0	40.0	10.00
R4598.8	–	8.80	0.3465	106.0	152.0	40.0	10.00
R4598.9	–	8.90	0.3504	106.0	152.0	40.0	10.00
R4599.0	–	9.00	0.3543	106.0	152.0	40.0	10.00
R4599.1	–	9.10	0.3583	106.0	152.0	40.0	10.00
R45923/64	23/64	9.13	0.3594	106.0	152.0	40.0	10.00
R4599.2	–	9.20	0.3622	106.0	152.0	40.0	10.00
R4599.3	–	9.30	0.3661	106.0	152.0	40.0	10.00
R4599.4	–	9.40	0.3701	106.0	152.0	40.0	10.00
R4599.5	–	9.50	0.3740	106.0	152.0	40.0	10.00
R4593/8	3/8	9.53	0.3750	106.0	152.0	40.0	10.00
R4599.6	–	9.60	0.3780	106.0	152.0	40.0	10.00
R4599.7	–	9.70	0.3819	106.0	152.0	40.0	10.00
R4599.8	–	9.80	0.3858	106.0	152.0	40.0	10.00
R4599.9	–	9.90	0.3898	106.0	152.0	40.0	10.00



Produit	DC	DC	DC	LCF	OAL	LS	DCON MS
	(inch)	(mm)	(inch)	(mm)	(mm)	(mm)	(mm)
R45925/64	25/64	9.92	0.3906	106.0	152.0	40.0	10.00
R45910.0	–	10.00	0.3937	106.0	152.0	40.0	10.00
R45910.2	–	10.20	0.4016	128.0	180.0	45.0	12.00
R45910.3	–	10.30	0.4055	128.0	180.0	45.0	12.00
R45913/32	13/32	10.32	0.4063	128.0	180.0	45.0	12.00
R45910.4	–	10.40	0.4094	128.0	180.0	45.0	12.00
R45910.5	–	10.50	0.4134	128.0	180.0	45.0	12.00
R45927/64	27/64	10.72	0.4219	128.0	180.0	45.0	12.00
R45910.8	–	10.80	0.4252	128.0	180.0	45.0	12.00
R45911.0	–	11.00	0.4331	128.0	180.0	45.0	12.00
R4597/16	7/16	11.11	0.4375	128.0	180.0	45.0	12.00
R45911.2	–	11.20	0.4409	128.0	180.0	45.0	12.00
R45911.3	–	11.30	0.4449	128.0	180.0	45.0	12.00
R45911.5	–	11.50	0.4528	128.0	180.0	45.0	12.00
R45929/64	29/64	11.51	0.4531	128.0	180.0	45.0	12.00
R45911.8	–	11.80	0.4646	128.0	180.0	45.0	12.00
R45915/32	15/32	11.91	0.4688	128.0	180.0	45.0	12.00
R45912.0	–	12.00	0.4724	128.0	180.0	45.0	12.00
R45912.2	–	12.20	0.4803	151.0	202.0	48.0	14.00
R45931/64	31/64	12.30	0.4844	151.0	202.0	48.0	14.00
R45912.5	–	12.50	0.4921	151.0	202.0	48.0	14.00
R4591/2	1/2	12.70	0.5000	151.0	202.0	48.0	14.00
R45912.8	–	12.80	0.5039	151.0	202.0	48.0	14.00
R45913.0	–	13.00	0.5118	151.0	202.0	48.0	14.00
R45933/64	33/64	13.10	0.5156	151.0	202.0	48.0	14.00
R45917/32	17/32	13.49	0.5313	151.0	202.0	48.0	14.00
R45913.5	–	13.50	0.5315	151.0	202.0	48.0	14.00
R45935/64	35/64	13.89	0.5469	151.0	202.0	48.0	14.00
R45914.0	–	14.00	0.5512	151.0	202.0	48.0	14.00
R45914.25	–	14.25	0.5610	172.0	227.0	48.0	16.00
R4599/16	9/16	14.29	0.5625	172.0	227.0	48.0	16.00
R45914.5	–	14.50	0.5709	172.0	227.0	48.0	16.00
R45937/64	37/64	14.68	0.5781	172.0	227.0	48.0	16.00
R45915.0	–	15.00	0.5906	172.0	227.0	48.0	16.00
R45919/32	19/32	15.08	0.5938	172.0	227.0	48.0	16.00
R45915.1	–	15.10	0.5945	172.0	227.0	48.0	16.00
R45939/64	39/64	15.48	0.6094	172.0	227.0	48.0	16.00
R45915.5	–	15.50	0.6102	172.0	227.0	48.0	16.00
R4595/8	5/8	15.88	0.6250	172.0	227.0	48.0	16.00
R45916.0	–	16.00	0.6299	172.0	227.0	48.0	16.00



R467

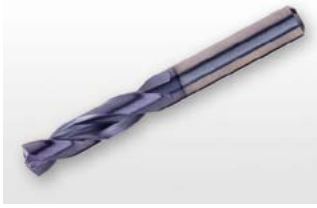

Foret carbure monobloc FORCE M longueur 3xD avec arrosage centralisé, revêtement TiAIN

Foret haute performance capable de produire des trous précis de haute qualité à des vitesses et des avances élevées (tolérance de trou H9 dans les aciers inoxydables et les matériaux réfractaires). Pointe auto-centrante à 140° avec 4 facettes et une conception de goujure CTW. L'arrosage centralisé améliore l'évacuation des copeaux. Le revêtement TiAIN augmente la dureté en surface et améliore la durée de vie de l'outil.

FORCE M

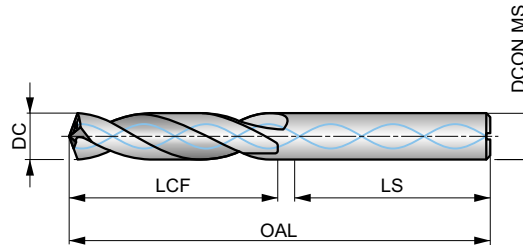

HM	DIN 6537K	3xD
140°	TiAIN	DIN 6535HA
CTW	DC m7	

Adéquation du groupe de matériaux de la pièce, valeurs de départ pour la vitesse de coupe (m/min) et code Alpha d'avance. Les tableaux d'avances par tour se trouvent à partir de la page 65.

M1.1 ■ 117 G	M1.2 ■ 99 G	M2.1 ■ 104 G	M2.2 ■ 85 G	M2.3 ■ 71 E	M3.1 ■ 87 G	M3.2 ■ 75 G	M3.3 ■ 68 F	M4.1 ■ 60 F	M4.2 ■ 52 E	S1.1 ■ 55 V	S1.2 ■ 45 V	S1.3 ■ 40 U	S2.1 ■ 60 U
S2.2 ■ 56 U	S3.1 ■ 45 U	S3.2 ■ 40 U	S4.1 ■ 35 U	S4.2 ■ 32 U									

DCON MS tolérance h6.

Produit	DC	DC	DC	LCF	OAL	LS	DCON MS
	(inch)	(mm)	(inch)	(mm)	(mm)	(mm)	(mm)
R4673.0	–	3.00	0.1181	20.0	62.0	36.0	6.00
R4673.1	–	3.10	0.1220	20.0	62.0	36.0	6.00
R4671/8	1/8	3.18	0.1250	20.0	62.0	36.0	6.00
R4673.2	–	3.20	0.1260	20.0	62.0	36.0	6.00
R4673.3	–	3.30	0.1299	20.0	62.0	36.0	6.00
R4673.4	–	3.40	0.1339	20.0	62.0	36.0	6.00
R467N29	N29	3.45	0.1360	20.0	62.0	36.0	6.00
R4673.5	–	3.50	0.1378	20.0	62.0	36.0	6.00
R4679/64	9/64	3.57	0.1406	20.0	62.0	36.0	6.00
R4673.6	–	3.60	0.1417	20.0	62.0	36.0	6.00
R4673.7	–	3.70	0.1457	20.0	62.0	36.0	6.00
R4673.8	–	3.80	0.1496	24.0	66.0	36.0	6.00
R4673.9	–	3.90	0.1535	24.0	66.0	36.0	6.00
R4675/32	5/32	3.97	0.1563	24.0	66.0	36.0	6.00
R4674.0	–	4.00	0.1575	24.0	66.0	36.0	6.00
R4674.05	–	4.05	0.1594	24.0	66.0	36.0	6.00
R4674.1	–	4.10	0.1614	24.0	66.0	36.0	6.00
R4674.2	–	4.20	0.1654	24.0	66.0	36.0	6.00
R4674.3	–	4.30	0.1693	24.0	66.0	36.0	6.00
R46711/64	11/64	4.37	0.1719	24.0	66.0	36.0	6.00
R4674.4	–	4.40	0.1732	24.0	66.0	36.0	6.00
R4674.5	–	4.50	0.1772	24.0	66.0	36.0	6.00
R4674.6	–	4.60	0.1811	24.0	66.0	36.0	6.00
R4674.7	–	4.70	0.1850	24.0	66.0	36.0	6.00
R4673/16	3/16	4.76	0.1875	28.0	66.0	36.0	6.00
R4674.8	–	4.80	0.1890	28.0	66.0	36.0	6.00
R4674.9	–	4.90	0.1929	28.0	66.0	36.0	6.00
R4675.0	–	5.00	0.1969	28.0	66.0	36.0	6.00
R4675.05	–	5.05	0.1988	28.0	66.0	36.0	6.00



Produit	DC	DC	DC	LCF	OAL	LS	DCON MS
	(inch)	(mm)	(inch)	(mm)	(mm)	(mm)	(mm)
R4675.1	—	5.10	0.2008	28.0	66.0	36.0	6.00
R467N7	N7	5.11	0.2010	28.0	66.0	36.0	6.00
R46713/64	13/64	5.16	0.2031	28.0	66.0	36.0	6.00
R4675.2	—	5.20	0.2047	28.0	66.0	36.0	6.00
R467N5	N5	5.22	0.2055	28.0	66.0	36.0	6.00
R4675.3	—	5.30	0.2087	28.0	66.0	36.0	6.00
R4675.4	—	5.40	0.2126	28.0	66.0	36.0	6.00
R4675.5	—	5.50	0.2165	28.0	66.0	36.0	6.00
R4677/32	7/32	5.56	0.2188	28.0	66.0	36.0	6.00
R4675.6	—	5.60	0.2205	28.0	66.0	36.0	6.00
R4675.7	—	5.70	0.2244	28.0	66.0	36.0	6.00
R4675.8	—	5.80	0.2283	28.0	66.0	36.0	6.00
R4675.9	—	5.90	0.2323	28.0	66.0	36.0	6.00
R46715/64	15/64	5.95	0.2344	28.0	66.0	36.0	6.00
R4676.0	—	6.00	0.2362	28.0	66.0	36.0	6.00
R4676.05	—	6.05	0.2382	34.0	79.0	36.0	8.00
R4676.1	—	6.10	0.2402	34.0	79.0	36.0	8.00
R4676.2	—	6.20	0.2441	34.0	79.0	36.0	8.00
R4676.3	—	6.30	0.2480	34.0	79.0	36.0	8.00
R4671/4	1/4	6.35	0.2500	34.0	79.0	36.0	8.00
R4676.4	—	6.40	0.2520	34.0	79.0	36.0	8.00
R4676.5	—	6.50	0.2559	34.0	79.0	36.0	8.00
R4676.6	—	6.60	0.2598	34.0	79.0	36.0	8.00
R4676.7	—	6.70	0.2638	34.0	79.0	36.0	8.00
R46717/64	17/64	6.75	0.2656	34.0	79.0	36.0	8.00
R4676.8	—	6.80	0.2677	34.0	79.0	36.0	8.00
R4676.9	—	6.90	0.2717	34.0	79.0	36.0	8.00
R4677.0	—	7.00	0.2756	34.0	79.0	36.0	8.00
R4677.1	—	7.10	0.2795	41.0	79.0	36.0	8.00
R4679/32	9/32	7.14	0.2813	41.0	79.0	36.0	8.00
R4677.2	—	7.20	0.2835	41.0	79.0	36.0	8.00
R4677.3	—	7.30	0.2874	41.0	79.0	36.0	8.00
R4677.4	—	7.40	0.2913	41.0	79.0	36.0	8.00
R4677.5	—	7.50	0.2953	41.0	79.0	36.0	8.00
R46719/64	19/64	7.54	0.2969	41.0	79.0	36.0	8.00
R4677.6	—	7.60	0.2992	41.0	79.0	36.0	8.00
R4677.7	—	7.70	0.3031	41.0	79.0	36.0	8.00
R4677.8	—	7.80	0.3071	41.0	79.0	36.0	8.00
R4677.9	—	7.90	0.3110	41.0	79.0	36.0	8.00
R4675/16	5/16	7.94	0.3125	41.0	79.0	36.0	8.00
R4678.0	—	8.00	0.3150	41.0	79.0	36.0	8.00
R4678.05	—	8.05	0.3169	47.0	89.0	40.0	10.00
R4678.1	—	8.10	0.3189	47.0	89.0	40.0	10.00
R4678.2	—	8.20	0.3228	47.0	89.0	40.0	10.00
R4678.3	—	8.30	0.3268	47.0	89.0	40.0	10.00
R46721/64	21/64	8.33	0.3281	47.0	89.0	40.0	10.00
R4678.4	—	8.40	0.3307	47.0	89.0	40.0	10.00
R4678.5	—	8.50	0.3346	47.0	89.0	40.0	10.00
R4678.6	—	8.60	0.3386	47.0	89.0	40.0	10.00
R4678.7	—	8.70	0.3425	47.0	89.0	40.0	10.00
R46711/32	11/32	8.73	0.3438	47.0	89.0	40.0	10.00
R4678.8	—	8.80	0.3465	47.0	89.0	40.0	10.00
R4678.9	—	8.90	0.3504	47.0	89.0	40.0	10.00
R4679.0	—	9.00	0.3543	47.0	89.0	40.0	10.00
R4679.1	—	9.10	0.3583	47.0	89.0	40.0	10.00
R46723/64	23/64	9.13	0.3594	47.0	89.0	40.0	10.00
R4679.2	—	9.20	0.3622	47.0	89.0	40.0	10.00
R4679.3	—	9.30	0.3661	47.0	89.0	40.0	10.00
R4679.4	—	9.40	0.3701	47.0	89.0	40.0	10.00
R4679.5	—	9.50	0.3740	47.0	89.0	40.0	10.00
R4673/8	3/8	9.53	0.3750	47.0	89.0	40.0	10.00
R4679.6	—	9.60	0.3780	47.0	89.0	40.0	10.00



Produit	DC	DC	DC	LCF	OAL	LS	DCON MS
	(inch)	(mm)	(inch)	(mm)	(mm)	(mm)	(mm)
R4679.7	–	9.70	0.3819	47.0	89.0	40.0	10.00
R4679.8	–	9.80	0.3858	47.0	89.0	40.0	10.00
R4679.9	–	9.90	0.3898	47.0	89.0	40.0	10.00
R46725/64	25/64	9.92	0.3906	47.0	89.0	40.0	10.00
R46710.0	–	10.00	0.3937	47.0	89.0	40.0	10.00
R46710.05	–	10.05	0.3957	55.0	102.0	45.0	12.00
R46710.1	–	10.10	0.3976	55.0	102.0	45.0	12.00
R46710.2	–	10.20	0.4016	55.0	102.0	45.0	12.00
R46710.3	–	10.30	0.4055	55.0	102.0	45.0	12.00
R46713/32	13/32	10.32	0.4063	55.0	102.0	45.0	12.00
R46710.4	–	10.40	0.4094	55.0	102.0	45.0	12.00
R46710.5	–	10.50	0.4134	55.0	102.0	45.0	12.00
R46710.6	–	10.60	0.4173	55.0	102.0	45.0	12.00
R46727/64	27/64	10.72	0.4219	55.0	102.0	45.0	12.00
R46710.8	–	10.80	0.4252	55.0	102.0	45.0	12.00
R46710.9	–	10.90	0.4291	55.0	102.0	45.0	12.00
R46711.0	–	11.00	0.4331	55.0	102.0	45.0	12.00
R4677/16	7/16	11.11	0.4375	55.0	102.0	45.0	12.00
R46711.2	–	11.20	0.4409	55.0	102.0	45.0	12.00
R46711.3	–	11.30	0.4449	55.0	102.0	45.0	12.00
R46711.4	–	11.40	0.4488	55.0	102.0	45.0	12.00
R46711.5	–	11.50	0.4528	55.0	102.0	45.0	12.00
R46729/64	29/64	11.51	0.4531	55.0	102.0	45.0	12.00
R46711.6	–	11.60	0.4567	55.0	102.0	45.0	12.00
R46711.8	–	11.80	0.4646	55.0	102.0	45.0	12.00
R46715/32	15/32	11.91	0.4688	55.0	102.0	45.0	12.00
R46712.0	–	12.00	0.4724	55.0	102.0	45.0	12.00
R46712.05	–	12.05	0.4744	60.0	107.0	45.0	14.00
R46712.1	–	12.10	0.4764	60.0	107.0	45.0	14.00
R46712.2	–	12.20	0.4803	60.0	107.0	45.0	14.00
R46731/64	31/64	12.30	0.4844	60.0	107.0	45.0	14.00
R46712.5	–	12.50	0.4921	60.0	107.0	45.0	14.00
R46712.7	–	12.70	0.5000	60.0	107.0	45.0	14.00
R4671/2	1/2	12.70	0.5000	60.0	107.0	45.0	14.00
R46712.8	–	12.80	0.5039	60.0	107.0	45.0	14.00
R46713.0	–	13.00	0.5118	60.0	107.0	45.0	14.00
R46733/64	33/64	13.10	0.5156	60.0	107.0	45.0	14.00
R46713.3	–	13.30	0.5236	60.0	107.0	45.0	14.00
R46717/32	17/32	13.49	0.5313	60.0	107.0	45.0	14.00
R46713.5	–	13.50	0.5315	60.0	107.0	45.0	14.00
R46713.8	–	13.80	0.5433	60.0	107.0	45.0	14.00
R46735/64	35/64	13.89	0.5469	60.0	107.0	45.0	14.00
R46714.0	–	14.00	0.5512	60.0	107.0	45.0	14.00
R46714.25	–	14.25	0.5610	65.0	115.0	48.0	16.00
R4679/16	9/16	14.29	0.5625	65.0	115.0	48.0	16.00
R46714.5	–	14.50	0.5709	65.0	115.0	48.0	16.00
R46737/64	37/64	14.68	0.5781	65.0	115.0	48.0	16.00
R46714.8	–	14.80	0.5827	65.0	115.0	48.0	16.00
R46715.0	–	15.00	0.5906	65.0	115.0	48.0	16.00
R46719/32	19/32	15.08	0.5938	65.0	115.0	48.0	16.00
R46715.1	–	15.10	0.5945	65.0	115.0	48.0	16.00
R46715.3	–	15.30	0.6024	65.0	115.0	48.0	16.00
R46739/64	39/64	15.48	0.6094	65.0	115.0	48.0	16.00
R46715.5	–	15.50	0.6102	65.0	115.0	48.0	16.00
R46715.8	–	15.80	0.6220	65.0	115.0	48.0	16.00
R4675/8	5/8	15.88	0.6250	65.0	115.0	48.0	16.00
R46716.0	–	16.00	0.6299	65.0	115.0	48.0	16.00



R463



Foret carbure monobloc FORCE M longueur 5xD avec arrosage centralisé, revêtement TiAlN

Foret haute performance capable de produire des trous précis de haute qualité à des vitesses et des avances élevées (tolérance de trou H9 dans les aciers inoxydables et les matériaux réfractaires). Une pointe à 140° avec 4 facettes et une conception de goujure CTW. L'arrosage centralisé améliore l'évacuation des copeaux. Le revêtement TiAlN augmente la dureté en surface et améliore la durée de vie de l'outil.

FORCE M

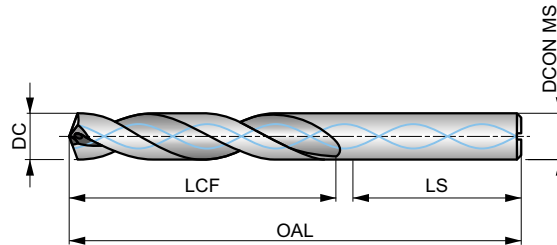

HM	DIN 6537L	5xD
140°	TiAlN	DIN 6535HA
CTW	DC m7	

Adéquation du groupe de matériaux de la pièce, valeurs de départ pour la vitesse de coupe (m/min) et code Alpha d'avance. Les tableaux d'avances par tour se trouvent à partir de la page 65.

M1.1 ■ 111 G	M1.2 ■ 94 G	M2.1 ■ 99 G	M2.2 ■ 81 G	M2.3 ■ 67 E	M3.1 ■ 83 G	M3.2 ■ 71 G	M3.3 ■ 65 F	M4.1 ■ 57 F	M4.2 ■ 49 E	S1.1 ■ 52 V	S1.2 ■ 43 V	S1.3 ■ 38 U	S2.1 ■ 57 U
S2.2 ■ 53 U	S3.1 ■ 43 U	S3.2 ■ 38 U	S4.1 ■ 33 U	S4.2 ■ 30 U									

DCON MS tolérance h6.

Produit	DC	DC	DC	LCF	OAL	LS	DCON MS
	(inch)	(mm)	(inch)	(mm)	(mm)	(mm)	(mm)
R4633.0	–	3.00	0.1181	28.0	66.0	36.0	6.00
R4633.1	–	3.10	0.1220	28.0	66.0	36.0	6.00
R4631/8	1/8	3.18	0.1250	28.0	66.0	36.0	6.00
R4633.2	–	3.20	0.1260	28.0	66.0	36.0	6.00
R4633.3	–	3.30	0.1299	28.0	66.0	36.0	6.00
R4633.4	–	3.40	0.1339	28.0	66.0	36.0	6.00
R463N29	N29	3.45	0.1360	28.0	66.0	36.0	6.00
R4633.5	–	3.50	0.1378	28.0	66.0	36.0	6.00
R4639/64	9/64	3.57	0.1406	28.0	66.0	36.0	6.00
R4633.6	–	3.60	0.1417	28.0	66.0	36.0	6.00
R4633.7	–	3.70	0.1457	28.0	66.0	36.0	6.00
R4633.8	–	3.80	0.1496	36.0	74.0	36.0	6.00
R4633.9	–	3.90	0.1535	36.0	74.0	36.0	6.00
R4635/32	5/32	3.97	0.1563	36.0	74.0	36.0	6.00
R4634.0	–	4.00	0.1575	36.0	74.0	36.0	6.00
R4634.05	–	4.05	0.1594	36.0	74.0	36.0	6.00
R4634.1	–	4.10	0.1614	36.0	74.0	36.0	6.00
R4634.2	–	4.20	0.1654	36.0	74.0	36.0	6.00
R4634.3	–	4.30	0.1693	36.0	74.0	36.0	6.00
R46311/64	11/64	4.37	0.1719	36.0	74.0	36.0	6.00
R4634.4	–	4.40	0.1732	36.0	74.0	36.0	6.00
R4634.5	–	4.50	0.1772	36.0	74.0	36.0	6.00
R4634.6	–	4.60	0.1811	36.0	74.0	36.0	6.00
R4634.7	–	4.70	0.1850	36.0	74.0	36.0	6.00
R4633/16	3/16	4.76	0.1875	44.0	82.0	36.0	6.00
R4634.8	–	4.80	0.1890	44.0	82.0	36.0	6.00
R4634.9	–	4.90	0.1929	44.0	82.0	36.0	6.00
R4635.0	–	5.00	0.1969	44.0	82.0	36.0	6.00
R4635.05	–	5.05	0.1988	44.0	82.0	36.0	6.00



Produit	DC	DC	DC	LCF	OAL	LS	DCON MS
	(inch)	(mm)	(inch)	(mm)	(mm)	(mm)	(mm)
R4635.1	–	5.10	0.2008	44.0	82.0	36.0	6.00
R463N7	N7	5.11	0.2010	44.0	82.0	36.0	6.00
R46313/64	13/64	5.16	0.2031	44.0	82.0	36.0	6.00
R4635.2	–	5.20	0.2047	44.0	82.0	36.0	6.00
R463N5	N5	5.22	0.2055	44.0	82.0	36.0	6.00
R4635.3	–	5.30	0.2087	44.0	82.0	36.0	6.00
R4635.4	–	5.40	0.2126	44.0	82.0	36.0	6.00
R4635.5	–	5.50	0.2165	44.0	82.0	36.0	6.00
R4637/32	7/32	5.56	0.2188	44.0	82.0	36.0	6.00
R4635.6	–	5.60	0.2205	44.0	82.0	36.0	6.00
R4635.7	–	5.70	0.2244	44.0	82.0	36.0	6.00
R4635.8	–	5.80	0.2283	44.0	82.0	36.0	6.00
R4635.9	–	5.90	0.2323	44.0	82.0	36.0	6.00
R46315/64	15/64	5.95	0.2344	44.0	82.0	36.0	6.00
R4636.0	–	6.00	0.2362	44.0	82.0	36.0	6.00
R4636.05	–	6.05	0.2382	53.0	91.0	36.0	8.00
R4636.1	–	6.10	0.2402	53.0	91.0	36.0	8.00
R4636.2	–	6.20	0.2441	53.0	91.0	36.0	8.00
R4636.3	–	6.30	0.2480	53.0	91.0	36.0	8.00
R4631/4	1/4	6.35	0.2500	53.0	91.0	36.0	8.00
R4636.4	–	6.40	0.2520	53.0	91.0	36.0	8.00
R4636.5	–	6.50	0.2559	53.0	91.0	36.0	8.00
R4636.6	–	6.60	0.2598	53.0	91.0	36.0	8.00
R4636.7	–	6.70	0.2638	53.0	91.0	36.0	8.00
R46317/64	17/64	6.75	0.2656	53.0	91.0	36.0	8.00
R4636.8	–	6.80	0.2677	53.0	91.0	36.0	8.00
R4636.9	–	6.90	0.2717	53.0	91.0	36.0	8.00
R4637.0	–	7.00	0.2756	53.0	91.0	36.0	8.00
R4637.1	–	7.10	0.2795	53.0	91.0	36.0	8.00
R4639/32	9/32	7.14	0.2813	53.0	91.0	36.0	8.00
R4637.2	–	7.20	0.2835	53.0	91.0	36.0	8.00
R4637.3	–	7.30	0.2874	53.0	91.0	36.0	8.00
R4637.4	–	7.40	0.2913	53.0	91.0	36.0	8.00
R4637.5	–	7.50	0.2953	53.0	91.0	36.0	8.00
R46319/64	19/64	7.54	0.2969	53.0	91.0	36.0	8.00
R4637.6	–	7.60	0.2992	53.0	91.0	36.0	8.00
R4637.7	–	7.70	0.3031	53.0	91.0	36.0	8.00
R4637.8	–	7.80	0.3071	53.0	91.0	36.0	8.00
R4637.9	–	7.90	0.3110	53.0	91.0	36.0	8.00
R4635/16	5/16	7.94	0.3125	53.0	91.0	36.0	8.00
R4638.0	–	8.00	0.3150	53.0	91.0	36.0	8.00
R4638.05	–	8.05	0.3169	61.0	103.0	40.0	10.00
R4638.1	–	8.10	0.3189	61.0	103.0	40.0	10.00
R4638.2	–	8.20	0.3228	61.0	103.0	40.0	10.00
R4638.3	–	8.30	0.3268	61.0	103.0	40.0	10.00
R46321/64	21/64	8.33	0.3281	61.0	103.0	40.0	10.00
R4638.4	–	8.40	0.3307	61.0	103.0	40.0	10.00
R4638.5	–	8.50	0.3346	61.0	103.0	40.0	10.00
R4638.6	–	8.60	0.3386	61.0	103.0	40.0	10.00
R4638.7	–	8.70	0.3425	61.0	103.0	40.0	10.00
R46311/32	11/32	8.73	0.3438	61.0	103.0	40.0	10.00
R4638.8	–	8.80	0.3465	61.0	103.0	40.0	10.00
R4638.9	–	8.90	0.3504	61.0	103.0	40.0	10.00
R4639.0	–	9.00	0.3543	61.0	103.0	40.0	10.00
R4639.1	–	9.10	0.3583	61.0	103.0	40.0	10.00
R46323/64	23/64	9.13	0.3594	61.0	103.0	40.0	10.00
R4639.2	–	9.20	0.3622	61.0	103.0	40.0	10.00
R4639.3	–	9.30	0.3661	61.0	103.0	40.0	10.00
R4639.4	–	9.40	0.3701	61.0	103.0	40.0	10.00
R4639.5	–	9.50	0.3740	61.0	103.0	40.0	10.00
R4633/8	3/8	9.53	0.3750	61.0	103.0	40.0	10.00
R4639.6	–	9.60	0.3780	61.0	103.0	40.0	10.00



Produit	DC	DC	DC	LCF	OAL	LS	DCON MS
	(inch)	(mm)	(inch)	(mm)	(mm)	(mm)	(mm)
R4639.7	–	9.70	0.3819	61.0	103.0	40.0	10.00
R4639.8	–	9.80	0.3858	61.0	103.0	40.0	10.00
R4639.9	–	9.90	0.3898	61.0	103.0	40.0	10.00
R46325/64	25/64	9.92	0.3906	61.0	103.0	40.0	10.00
R46310.0	–	10.00	0.3937	61.0	103.0	40.0	10.00
R46310.05	–	10.05	0.3957	70.0	118.0	45.0	12.00
R46310.1	–	10.10	0.3976	70.0	118.0	45.0	12.00
R46310.2	–	10.20	0.4016	70.0	118.0	45.0	12.00
R46310.3	–	10.30	0.4055	70.0	118.0	45.0	12.00
R46313/32	13/32	10.32	0.4063	70.0	118.0	45.0	12.00
R46310.4	–	10.40	0.4094	70.0	118.0	45.0	12.00
R46310.5	–	10.50	0.4134	70.0	118.0	45.0	12.00
R46310.6	–	10.60	0.4173	70.0	118.0	45.0	12.00
R46327/64	27/64	10.72	0.4219	70.0	118.0	45.0	12.00
R46310.8	–	10.80	0.4252	70.0	118.0	45.0	12.00
R46310.9	–	10.90	0.4291	70.0	118.0	45.0	12.00
R46311.0	–	11.00	0.4331	70.0	118.0	45.0	12.00
R4637/16	7/16	11.11	0.4375	70.0	118.0	45.0	12.00
R46311.2	–	11.20	0.4409	70.0	118.0	45.0	12.00
R46311.3	–	11.30	0.4449	70.0	118.0	45.0	12.00
R46311.4	–	11.40	0.4488	70.0	118.0	45.0	12.00
R46311.5	–	11.50	0.4528	70.0	118.0	45.0	12.00
R46329/64	29/64	11.51	0.4531	70.0	118.0	45.0	12.00
R46311.6	–	11.60	0.4567	70.0	118.0	45.0	12.00
R46311.8	–	11.80	0.4646	70.0	118.0	45.0	12.00
R46315/32	15/32	11.91	0.4688	70.0	118.0	45.0	12.00
R46312.0	–	12.00	0.4724	70.0	118.0	45.0	12.00
R46312.05	–	12.05	0.4744	76.0	124.0	45.0	14.00
R46312.2	–	12.20	0.4803	76.0	124.0	45.0	14.00
R46331/64	31/64	12.30	0.4844	76.0	124.0	45.0	14.00
R46312.5	–	12.50	0.4921	76.0	124.0	45.0	14.00
R46312.7	–	12.70	0.5000	76.0	124.0	45.0	14.00
R4631/2	1/2	12.70	0.5000	76.0	124.0	45.0	14.00
R46312.8	–	12.80	0.5039	76.0	124.0	45.0	14.00
R46313.0	–	13.00	0.5118	76.0	124.0	45.0	14.00
R46333/64	33/64	13.10	0.5156	76.0	124.0	45.0	14.00
R46313.3	–	13.30	0.5236	76.0	124.0	45.0	14.00
R46317/32	17/32	13.49	0.5313	76.0	124.0	45.0	14.00
R46313.5	–	13.50	0.5315	76.0	124.0	45.0	14.00
R46313.8	–	13.80	0.5433	76.0	124.0	45.0	14.00
R46335/64	35/64	13.89	0.5469	76.0	124.0	45.0	14.00
R46314.0	–	14.00	0.5512	76.0	124.0	45.0	14.00
R46314.25	–	14.25	0.5610	82.0	133.0	48.0	16.00
R4639/16	9/16	14.29	0.5625	82.0	133.0	48.0	16.00
R46314.5	–	14.50	0.5709	82.0	133.0	48.0	16.00
R46337/64	37/64	14.68	0.5781	82.0	133.0	48.0	16.00
R46314.8	–	14.80	0.5827	82.0	133.0	48.0	16.00
R46315.0	–	15.00	0.5906	82.0	133.0	48.0	16.00
R46319/32	19/32	15.08	0.5938	82.0	133.0	48.0	16.00
R46315.1	–	15.10	0.5945	82.0	133.0	48.0	16.00
R46315.3	–	15.30	0.6024	82.0	133.0	48.0	16.00
R46339/64	39/64	15.48	0.6094	82.0	133.0	48.0	16.00
R46315.5	–	15.50	0.6102	82.0	133.0	48.0	16.00
R46315.8	–	15.80	0.6220	82.0	133.0	48.0	16.00
R4635/8	5/8	15.88	0.6250	82.0	133.0	48.0	16.00
R46316.0	–	16.00	0.6299	82.0	133.0	48.0	16.00



TABLEAU DES AVANCES POUR LES FORETS MONOBLOCS

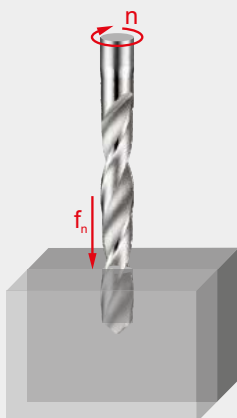

Avance par tour (f_n en mm/tr)
Ajuster ces valeurs de $\pm 25\%$ selon les conditions de travail.

Comment trouver l'avance par tour (f_n) grâce à ce tableau :

1. Rechercher le code Alpha sur la page produit (par ex. 46J, « J » étant le code Alpha).
2. Trouver le diamètre le plus proche de celui recherché pour votre application (première ligne du tableau).
3. Rechercher votre code Alpha dans la colonne gauche du tableau.
4. La cellule à l'intersection de la colonne Diamètre et de la ligne code Alpha indique l'avance par tour (f_n).

		ø DC (mm)																		
		0.15	0.50	1.00	2.00	3.00	4.00	5.00	6.00	8.00	10.00	12.00	15.00	16.00	20.00	25.00	30.00	40.00	50.00	100.00
Avances	A	0.003	0.006	0.012	0.023	0.029	0.032	0.036	0.042	0.054	0.062	0.069	0.082	0.086	0.110	0.125	0.135	0.155	0.175	0.263
	B	0.004	0.007	0.014	0.028	0.037	0.041	0.046	0.053	0.067	0.080	0.090	0.103	0.108	0.135	0.153	0.165	0.188	0.208	0.312
	C	0.004	0.008	0.015	0.032	0.044	0.050	0.056	0.064	0.080	0.098	0.110	0.125	0.130	0.160	0.180	0.195	0.220	0.240	0.360
	D	0.004	0.008	0.016	0.038	0.053	0.060	0.068	0.078	0.098	0.119	0.130	0.149	0.155	0.188	0.210	0.228	0.253	0.275	0.413
	E	0.004	0.009	0.017	0.043	0.062	0.071	0.080	0.092	0.115	0.140	0.150	0.173	0.180	0.215	0.240	0.260	0.285	0.310	0.465
	F	0.005	0.009	0.018	0.050	0.073	0.084	0.095	0.109	0.138	0.165	0.178	0.202	0.210	0.248	0.275	0.295	0.320	0.343	0.515
	G	0.005	0.010	0.019	0.056	0.084	0.096	0.109	0.126	0.160	0.190	0.205	0.231	0.240	0.280	0.310	0.330	0.355	0.375	0.563
	H	0.005	0.010	0.020	0.066	0.102	0.116	0.130	0.150	0.190	0.228	0.243	0.271	0.280	0.320	0.355	0.375	0.398	0.418	0.627
	I	0.005	0.011	0.021	0.076	0.119	0.134	0.150	0.173	0.220	0.265	0.280	0.310	0.320	0.360	0.400	0.420	0.440	0.460	0.690
	J	0.006	0.012	0.024	0.084	0.135	0.152	0.170	0.197	0.250	0.298	0.315	0.349	0.360	0.405	0.445	0.465	0.485	0.503	0.755
	K	0.007	0.013	0.026	0.092	0.150	0.170	0.190	0.220	0.280	0.330	0.350	0.388	0.400	0.450	0.490	0.510	0.530	0.545	0.818
	L	0.007	0.014	0.028	0.101	0.165	0.186	0.208	0.240	0.305	0.360	0.385	0.419	0.430	0.485	0.525	0.545	0.568	0.588	0.882
	M	0.008	0.015	0.030	0.110	0.180	0.202	0.225	0.260	0.330	0.390	0.420	0.450	0.460	0.520	0.560	0.580	0.605	0.630	0.945
	N	0.008	0.016	0.032	0.119	0.195	0.218	0.242	0.280	0.355	0.420	0.455	0.481	0.490	0.555	0.595	0.615	0.642	0.672	1.008
	S	0.002	0.004	0.008	0.014	0.020	0.025	0.030	0.037	0.050	0.080	0.100	0.123	0.130	0.150	0.170	0.190	0.220	0.240	–
	T	0.004	0.008	0.015	0.028	0.040	0.050	0.060	0.070	0.090	0.110	0.130	0.160	0.170	0.190	0.210	0.230	0.260	0.275	–
	U	0.007	0.013	0.026	0.048	0.070	0.080	0.090	0.107	0.140	0.170	0.200	0.223	0.230	0.240	0.270	0.300	0.360	0.375	–
	V	0.010	0.019	0.038	0.069	0.100	0.115	0.130	0.153	0.200	0.250	0.280	0.310	0.320	0.340	0.400	0.440	0.510	0.530	–
	W	0.012	0.025	0.049	0.089	0.130	0.150	0.170	0.200	0.260	0.330	0.380	0.418	0.430	0.450	0.470	0.490	0.520	0.540	–
	X	0.014	0.028	0.056	0.103	0.150	0.180	0.210	0.250	0.330	0.420	0.480	0.533	0.550	0.580	–	–	–	–	–
Y	0.017	0.034	0.068	0.124	0.180	0.220	0.260	0.317	0.430	0.550	0.700	0.700	0.700	0.740	–	–	–	–	–	
Z	0.024	0.047	0.094	0.172	0.250	0.325	0.400	0.533	0.800	1.000	1.100	1.175	1.200	1.200	–	–	–	–	–	





FORETS HSS



FORETS HSS – RECHERCHE PAR MATÉRIAU D'OUTIL





Matériaux

Acier rapide		Un acier rapide moyennement allié qui présente une bonne usinabilité et de bonnes performances. L'acier rapide présente des caractéristiques de dureté, de ténacité et de résistance à l'usure qui en font un bon choix pour une large gamme d'applications, notamment pour les forets et les tarauds.
Acier rapide au cobalt		Cet acier rapide contient du cobalt pour une dureté à chaud accrue. La composition du HSCo apporte une bonne combinaison de ténacité et de dureté. Il présente une bonne usinabilité et une bonne résistance à l'usure. Il convient donc à la production de forets, de tarauds, de fraises et d'alésoirs.





Carbures

Carbure et Acier rapide		Le carbure et l'acier rapide sont généralement combinés grâce à un alliage de brasage à haute température qui sert d'interface. La partie coupante en carbure monobloc assure une haute résistance à la compression, une dureté et une résistance à l'usure élevée, et le corps en acier rapide apporte une bonne résistance à la flexion et ténacité.
--------------------------------	---	--

Traitements superficiels

Brillant (non revêtu)		La finition brillante (surface non revêtue) facilite le glissement des copeaux dans les matériaux non-ferreux ou doux, les plastiques et les matériaux composites, tout en préservant le tranchant des arêtes de coupe.
Combinaison brillant et traitement vapeur		La combinaison de la finition brillante et du traitement vapeur apporte des avantages concrets : la surface plus poreuse de l'oxyde bleu attire et retient le fluide de coupe dans le trou tandis que la surface brillante facilite l'évacuation des copeaux. Cette combinaison s'obtient par meulage de la surface brillante après traitement vapeur.
Traitement vapeur		Le traitement vapeur apporte une finition de surface bleue particulièrement adhérente pour retenir le fluide de coupe et éviter que les copeaux ne se collent à l'outil. Il contribue donc à lutter contre la formation d'arêtes rapportées. Le traitement vapeur peut être appliqué sur n'importe quel outil brillant, mais il apporte de meilleurs résultats sur les forets et les tarauds.
Finition bronze		La finition bronze est créée par une couche fine et régulière d'oxyde de bronze sur toute la surface de l'outil. Similaire au traitement vapeur, elle évite que les copeaux ne se collent à l'outil et facilite l'évacuation des copeaux. Cette finition peut être appliquée à tous les outils brillants et peut être combinée avec le traitement vapeur (pour certains outils).

Revêtements de surface

Brillant et TiN (revêtement de pointe)		Le nitrure de titane est un revêtement céramique de couleur or appliqué par dépôt physique en phase vapeur (PVD). Une dureté élevée, associée à un faible frottement, permet d'augmenter la durée de vie des outils ou d'améliorer les performances de coupe par rapport à des outils non revêtus.
Nitrure de titane (TiN)		Le nitrure de titane est un revêtement céramique de couleur or appliqué par dépôt physique en phase vapeur (PVD). Une dureté élevée, associée à un faible frottement, permet d'augmenter la durée de vie des outils ou d'améliorer les performances de coupe par rapport à des outils non revêtus.
Nitrure de titane aluminium (TiAlN, TiAlN-Top et X-CEED)	 	Le nitrure de titane aluminium est un revêtement céramique multi-couche appliqué par procédé PVD. Il confère une ténacité et une stabilité à l'oxydation élevées. Ces propriétés en font un matériau idéal pour des vitesses et avances plus élevées, tout en améliorant la durée de vie des outils. Le TiAlN est utilisé dans le perçage, le taraudage et le fraisage. Il peut également convenir aux usinages sans refroidissement. Le revêtement TiAlN-Top est identique au TiAlN, mais il subit un traitement après revêtement pour lisser les imperfections, améliorer le flux de copeaux et réduire la formation d'arêtes rapportées.
Alcrona (Alcrona-Top)		Les revêtements de la famille Alcrona (AlCrN) sont en nitrure de chrome aluminium ; ils sont principalement utilisés pour les fraises. Les deux propriétés spécifiques de ces revêtements sont une grande dureté à chaud et une résistance à l'oxydation élevée. Appliquées aux outils destinés à des usinages sous fortes contraintes mécaniques et thermiques, ces propriétés se traduisent par une résistance supérieure à l'usure. Plusieurs niveaux ou versions particulières de ces revêtements sont disponibles pour divers outils et applications.



Code de matériau du corps (BMC)		HSS-E	HSS	HSS	HSS	HSS	HSS	HSS-E	HSS-E	HSS	HSS HM	HSS-E	HSS-E	HSS-E
Groupe standard de base (BSG)			DIN 1897	DIN 1897	DIN 1897	DIN 1897	DIN ANSI	DIN 1897	DIN 1897	DIN 1897	DIN 8037	DIN 1899	DIN ANSI	DIN ANSI
Rapport longueur utile diamètre (ULDR)		1xD	1.25xD	1xD	1.5xD	2.5xD	2.5xD	2.5xD	2.5xD	2.5xD	2.5xD	2.5xD	3xD	3xD
Angle d'application		180°	120°	90°/120°	120°	135°	135°	130°	135°	130°	118°	118°	130°	130°
Revêtement														
Queue														
Forme d'hélice														
Sens (direction de coupe)														
Propriété d'alimentation en liquide de coupe (CSP)														
									ADX				PFX	PFX
Code de famille de produits		A723	A119	A122	A123	A120	A022	A620	A117	A520	A124	A720	A920	A921
		6.00 - 8.00	3.30 - 5.10	6.00 - 20.00	3/32 - 1/4	0.50 - 25.00	0.50 - 16.00	2.50 - 13.00	1.00 - 13.00	3.00 - 13.00	3.00 - 16.00	0.15 - 1.40	1.00 - 20.00	2.50 - 16.00
P	P1	■	■	■	■	■	■	■	■	■	■	■	■	■
	P2	■	■	■	■	■	■	■	■	■	■	■	■	■
	P3	■	■	■	■	■	■	■	■	■	■	■	■	■
	P4	■	■	■	■	■	■	■	■	■	■	■	■	■
M	M1		■	■	■	■	■	■	■	■	■	■	■	■
	M2		■	■	■	■	■	■	■	■	■	■	■	■
	M3		■	■	■	■	■	■	■	■	■	■	■	■
	M4		■	■	■	■	■	■	■	■	■	■	■	■
K	K1			■	■	■	■	■	■	■	■	■	■	■
	K2			■	■	■	■	■	■	■	■	■	■	■
	K3			■	■	■	■	■	■	■	■	■	■	■
	K4			■	■	■	■	■	■	■	■	■	■	■
	K5			■	■	■	■	■	■	■	■	■	■	■
N	N1		■	■	■	■	■	■	■	■	■	■	■	■
	N2		■	■	■	■	■	■	■	■	■	■	■	■
	N3		■	■	■	■	■	■	■	■	■	■	■	■
	N4		■	■	■	■	■	■	■	■	■	■	■	■
	N5													
S	S1		■	■	■	■	■	■	■	■	■	■	■	■
	S2		■	■	■	■	■	■	■	■	■	■	■	■
	S3		■	■	■	■	■	■	■	■	■	■	■	■
	S4		■	■	■	■	■	■	■	■	■	■	■	■
H	H1													
	H2													
	H3													
	H4													

■ Utilisation principale ■ Utilisation possible



	HSS	HSS	HSS	HSS	HSS	HSS-E	HSS-E	HSS HM	HSS	HSS-E	HSS-E	HSS-E	HSS	HSS	HSS	
	DIN 338	DIN 338	DIN 338	DIN 338	DIN 338	DIN 338	DIN 338	DIN 338	DIN 338	DIN 338	DIN ANSI	DIN ANSI	DIN ANSI	DIN 338	NAS 907	NAS 907
	4xD	4xD	4xD	4xD	4xD	4xD	4xD	4xD	4xD	4xD	5xD	6xD	6xD	4xD	4xD	4xD
	118°	118°	118°	118°	135°	130°	135°	118°	130°	130°	130°	130°	130°	118°	135°	118°
	TiN-Tip	TiN-Tip	ST	ST	ST	Bright	Bronze	Bright ST	TiN	TiAlN Top	Bright	Alcrona Top	ST	Bright	Bright	
	λ>20-35°	λ>20-35°	λ>20-35°	λ>20-35°	λ>35°	VA	λ>20-35°	λ>20-35°	λ>32-40°	λ>35°	λ>35°	λ>35°	λ>20-35°	λ>20-35°	λ>20-35°	
	R	R	R	L	R	R	R	R	R	R	R	R	R	R	R	
	A002	A002S	A100	A101	A108	A147	A777	A160	A510	A553	A900	A901	A170	A243	A244	
	1.00 - 16.00	2.00 - 13.00	0.20 - 20.00	1.00 - 12.00	1.00 - 16.00	0.30 - 15.0	0.30 - 16.00	4.00 - 16.00	3.00 - 14.00	5.00 - 20.00	1.00 - 20.00	1.50 - 16.00	13.00 - 1.1/2	3/32 - 1/4	1/8 - 1/4	
	96	98	99	103	104	106	108	110	111	113	114	116	118	120	121	
P1	■	■	■	■	■	■	■	■	■	■	■	■	■	■	■	■
P2	■	■	■	■	■	■	■	■	■	■	■	■	■	■	■	■
P3	■	■	■	■	■	■	■	■	■	■	■	■	■	■	■	■
P4	■	■	■	■	■	■	■	■	■	■	■	■	■	■	■	■
M1	■	■	■	■	■	■	■	■	■	■	■	■	■	■	■	■
M2	■	■	■	■	■	■	■	■	■	■	■	■	■	■	■	■
M3	■	■	■	■	■	■	■	■	■	■	■	■	■	■	■	■
M4	■	■	■	■	■	■	■	■	■	■	■	■	■	■	■	■
K1	■	■	■	■	■	■	■	■	■	■	■	■	■	■	■	■
K2	■	■	■	■	■	■	■	■	■	■	■	■	■	■	■	■
K3	■	■	■	■	■	■	■	■	■	■	■	■	■	■	■	■
K4	■	■	■	■	■	■	■	■	■	■	■	■	■	■	■	■
K5	■	■	■	■	■	■	■	■	■	■	■	■	■	■	■	■
N1	■	■	■	■	■	■	■	■	■	■	■	■	■	■	■	■
N2	■	■	■	■	■	■	■	■	■	■	■	■	■	■	■	■
N3	■	■	■	■	■	■	■	■	■	■	■	■	■	■	■	■
N4	■	■	■	■	■	■	■	■	■	■	■	■	■	■	■	■
N5	■	■	■	■	■	■	■	■	■	■	■	■	■	■	■	■
S1	■	■	■	■	■	■	■	■	■	■	■	■	■	■	■	■
S2	■	■	■	■	■	■	■	■	■	■	■	■	■	■	■	■
S3	■	■	■	■	■	■	■	■	■	■	■	■	■	■	■	■
S4	■	■	■	■	■	■	■	■	■	■	■	■	■	■	■	■
H1																
H2																
H3																
H4																

■ Utilisation principale □ Utilisation possible



Code de matériau du corps (BMC)		HSS	HSS-E	HSS-E	HSS	HSS-E	HSS-E	HSS-E	HSS	HSS	HSS-E	HSS HM	HSS	HSS
Groupe standard de base (BSG)		DIN 340	DIN ANSI	DIN ANSI	BS 328	DIN 1869-1	DIN 1869-2	DIN 1869-3	DIN 345	DIN 345	DIN 345	DIN 345	DIN 341	DIN 1870(1)
Rapport longueur utile diamètre (ULDR)		6×D	10×D	10×D	10×D	15×D	20×D	25×D	4×D	4×D	4×D	4×D	6×D	10×D
Angle d'application		118°	130°	130°	118°	130°	130°	130°	118°	118°	118°	118°	118°	118°
Revêtement		ST	Bright	Alcrona Top	ST	Bright	Bright	Bright	ST	TiN	Bronze	Bright ST	ST	ST
Queue														
Forme d'hélice		λ>20-35°	λ>35°	λ>35°	λ>20-35°	λ>35°	λ>35°	λ>35°	λ>20-35°	λ>20-35°	λ>20-35°	λ>20-35°	λ>20-35°	λ>20-35°
Sens (direction de coupe)														
Propriété d'alimentation en liquide de coupe (CSP)														
Code de famille de produits		A110	A940	A941	A125	A976	A977	A978	A130	A530	A730	A166	A350	A345
		0.50 - 1"	1.00 - 20.00	1.00 - 16.00	1.40 - 1"	1.50 - 14.00	1.50 - 14.00	3.00 - 10.00	3.00 - 50.80	8.50 - 40.00	10.00 - 32.00	10.00 - 33.00	5.00 - 50.00	8.00 - 50.00
P	P1	■	■	■	■	■	■	■	■	■	■	■	■	■
	P2	■	■	■	■	■	■	■	■	■	■	■	■	■
	P3	■	■	■	■	■	■	■	■	■	■	■	■	■
	P4	■	■	■	■	■	■	■	■	■	■	■	■	■
M	M1	■	■	■	■	■	■	■	■	■	■	■	■	■
	M2	■	■	■	■	■	■	■	■	■	■	■	■	■
	M3	■	■	■	■	■	■	■	■	■	■	■	■	■
	M4	■	■	■	■	■	■	■	■	■	■	■	■	■
K	K1	■	■	■	■	■	■	■	■	■	■	■	■	■
	K2	■	■	■	■	■	■	■	■	■	■	■	■	■
	K3	■	■	■	■	■	■	■	■	■	■	■	■	■
	K4	■	■	■	■	■	■	■	■	■	■	■	■	■
	K5	■	■	■	■	■	■	■	■	■	■	■	■	■
N	N1	■	■	■	■	■	■	■	■	■	■	■	■	■
	N2	■	■	■	■	■	■	■	■	■	■	■	■	■
	N3	■	■	■	■	■	■	■	■	■	■	■	■	■
	N4	■	■	■	■	■	■	■	■	■	■	■	■	■
	N5	■	■	■	■	■	■	■	■	■	■	■	■	■
S	S1	■	■	■	■	■	■	■	■	■	■	■	■	■
	S2	■	■	■	■	■	■	■	■	■	■	■	■	■
	S3	■	■	■	■	■	■	■	■	■	■	■	■	■
	S4	■	■	■	■	■	■	■	■	■	■	■	■	■
H	H1													
	H2													
	H3													
	H4													

■ Utilisation principale ■ Utilisation possible



	HSS	HSS	HSS	HSS	HSS	HSS	HSS	HSS	HSS	HSS-E	HSS-E	HSS	HSS	HSS	HSS-E
	DIN 1870(1)	DIN 1870(2)	DIN 8374	DIN 8376	DIN 8377	DORNER	DORNER	DIN 333A	DIN 333A	DIN 333A	DIN 333A	DIN 333R	DORNER	BS 328	DIN 333A
	15xD	20xD	4xD	4xD	4xD	2.5xD	2.5xD	1xD	1xD	1xD	1xD	1xD	1xD	1xD	1xD
	130°	130°	90°	180°	180°	90°	180°	60°	60°	60°	60°	R	60°	60°	60°
	Bright ST	Bright ST	ST	ST	ST	ST	ST	Bright	TN	Bright	TAIN	Bright	Bright	Bright	Bright
	$\lambda > 35^\circ$	$\lambda > 35^\circ$	$\lambda > 20-35^\circ$	$\lambda > 20-35^\circ$	$\lambda > 20-35^\circ$										
	R	R	R	R	R	R	R	R	R	R	R	R	R	R	R
	A951	A952	A400	A402	A405	A412	A413	A200	A205	A206	A266	A210	A201	A225	A237
	10.00 - 30.00	8.00 - 40.00	M3 - M10	M3 - M10	M6 - M18	M3 - M10	M3 - M10	0.50 - 12.50	1.00 - 5.00	1.00 - 5.00	1.00 - 5.00	0.50 - 10.00	0.63 - 6.00	3/64 - 5/16	1.60 - 10.00
	148	149	150	151	152	153	154	155	156	157	158	159	160	161	162
P1	■	■	■	■	■	■	■	■	■	■	■	■	■	■	■
P2	■	■	■	■	■	■	■	■	■	■	■	■	■	■	■
P3	■	■	■	■	■	■	■	■	■	■	■	■	■	■	■
P4	■	■	■	■	■	■	■	■	■	■	■	■	■	■	■
M1	■	■	■	■	■	■	■	■	■	■	■	■	■	■	■
M2	■	■	■	■	■	■	■	■	■	■	■	■	■	■	■
M3	■	■	■	■	■	■	■	■	■	■	■	■	■	■	■
M4	■	■	■	■	■	■	■	■	■	■	■	■	■	■	■
K1	■	■	■	■	■	■	■	■	■	■	■	■	■	■	■
K2	■	■	■	■	■	■	■	■	■	■	■	■	■	■	■
K3	■	■	■	■	■	■	■	■	■	■	■	■	■	■	■
K4	■	■	■	■	■	■	■	■	■	■	■	■	■	■	■
K5	■	■	■	■	■	■	■	■	■	■	■	■	■	■	■
N1	■	■	■	■	■	■	■	■	■	■	■	■	■	■	■
N2	■	■	■	■	■	■	■	■	■	■	■	■	■	■	■
N3	■	■	■	■	■	■	■	■	■	■	■	■	■	■	■
N4	■	■	■	■	■	■	■	■	■	■	■	■	■	■	■
N5															
S1	■	■	■	■	■	■	■	■	■	■	■	■	■	■	■
S2	■	■	■	■	■	■	■	■	■	■	■	■	■	■	■
S3	■	■	■	■	■	■	■	■	■	■	■	■	■	■	■
S4	■	■	■	■	■	■	■	■	■	■	■	■	■	■	■
H1															
H2															
H3															
H4															

■ Utilisation principale □ Utilisation possible



		HSS-E	HSS-E	HSS	HSS	HSS	HSS	HSS
		DIN 333R	DORMER	DIN ANSI	DIN 338	DIN 338	DIN 338	DIN 338
Code de matériau du corps (BMC)		HSS-E	HSS-E	HSS	HSS	HSS	HSS	HSS
Groupe standard de base (BSG)		DIN 333R	DORMER	DIN ANSI	DIN 338	DIN 338	DIN 338	DIN 338
Rapport longueur utile diamètre (ULDR)		1xD	1xD	2.5xD	4xD	4xD	4xD	4xD
Angle d'application		R	60°	135°	118°	118°	118°	118°
Revêtement		Bright	Bright	TiN-Tip	TiN-Tip	TiN-Tip	TiN-Tip	TiN-Tip
Queue		H						
Forme d'hélice				λ 20-35°	λ 20-35°	λ 20-35°	λ 20-35°	λ 20-35°
Sens (direction de coupe)		R	R	R	R	R	R	R
Propriété d'alimentation en liquide de coupe (CSP)								
Code de famille de produits		A238	A242	A088	A095	A087	A094	A089
		1.60 - 8.00	1.00 - 5.00	Set	Set	Set	Set	Set
		163	164	165	165	166	166	167
P	P1	■	■					
	P2	■	■					
	P3	■	■					
	P4	■	■					
M	M1	■	■					
	M2	■	■					
	M3	■	■					
	M4	■	■					
K	K1	■	■					
	K2	■	■					
	K3	■	■					
	K4	■	■					
	K5	■	■					
N	N1	■	■					
	N2	■	■					
	N3	■	■					
	N4	■	■					
	N5	■	■					
S	S1	■	■					
	S2	■	■					
	S3	■	■					
	S4	■	■					
H	H1							
	H2							
	H3							
	H4							

■ Utilisation principale ■ Utilisation possible



A099	A099	A199	A080	A190
-------------	-------------	-------------	-------------	-------------

Set	Drillboy	Set	Set	Set
-----	----------	-----	-----	-----

168	168	169	169	170
-----	-----	-----	-----	-----

P1				
P2				
P3				
P4				
M1				
M2				
M3				
M4				
K1				
K2				
K3				
K4				
K5				
N1				
N2				
N3				
N4				
N5				
S1				
S2				
S3				
S4				
H1				
H2				
H3				
H4				



Code de matériau du corps (BMC)
 Groupe standard de base (BSG)
 Rapport longueur utile diamètre (ULDR)
 Angle d'application
 Revêtement
 Queue
 Forme d'hélice
 Sens (direction de coupe)
 Propriété d'alimentation en liquide de coupe (CSP)

HSS	HSS	HSS	HSS-E			
DIN 338	DIN 338	DIN 338	DIN 338			
4xD	4xD	4xD	4xD			
118°	118°	135°	135°	60°		
ST	ST	ST	Bronze			
λ 20-35°	λ 20-35°	λ >35°	λ 20-35°			
R	R	R	R			



Code de famille de produits

A191	A191	A188	A295	A296	M150	M151
Set	Set	Set	Set	Set		
171	171	172	172	173	173	174

P	P1					
	P2					
	P3					
	P4					
M	M1					
	M2					
	M3					
	M4					
K	K1					
	K2					
	K3					
	K4					
	K5					
N	N1					
	N2					
	N3					
	N4					
	N5					
S	S1					
	S2					
	S3					
	S4					
H	H1					
	H2					
	H3					
	H4					

■ Utilisation principale ☑ Utilisation possible



M152

174

P1																						
P2																						
P3																						
P4																						
M1																						
M2																						
M3																						
M4																						
K1																						
K2																						
K3																						
K4																						
K5																						
N1																						
N2																						
N3																						
N4																						
N5																						
S1																						
S2																						
S3																						
S4																						
H1																						
H2																						
H3																						
H4																						



A723



Foret pour points de soudure en HSS-E (5% cobalt), finition avec traitement bronze

Foret doté d'une lèvre et d'une pointe saillante spécialement conçues pour enlever ou «désagréger» les zones soudées par points, généralement utilisé pour enlever les soudures dans un atelier de réparation de véhicules. La goujure courte le rend plus robuste et moins susceptible de se briser lorsqu'il est utilisé dans un appareil portatif. La finition avec traitement bronze est une fine couche d'oxyde et une indication pour le cobalt.

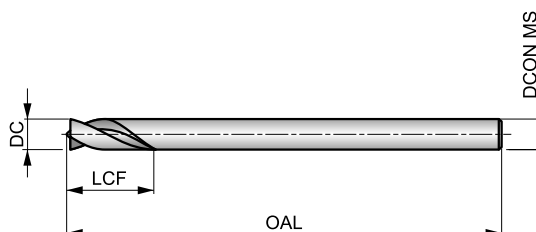

HSS-E	DORMER	1xD
Bronze		20-35°
R	DC h8	

Adéquation du groupe de matériaux de la pièce, valeurs de départ pour la vitesse de coupe (m/min) et code Alpha d'avance. Les tableaux d'avances par tour se trouvent à partir de la page 175.

P1.1 ■ 33 D	P1.2 ■ 37 D	P1.3 ■ 38 D	P2.1 ■ 28 D	P2.2 ■ 25 C	P3.1 ■ 20 C	P3.2 ■ 20 C	P4.1 ■ 20 C
-----------------------	-----------------------	-----------------------	-----------------------	-----------------------	-----------------------	-----------------------	-----------------------

Produit	DC	DC	LCF	OAL	DCON MS
	(mm)	(inch)			
A7236.0X66	6.00	0.2362	18.0	66.0	6.00
A7236.0X93	6.00	0.2362	18.0	93.0	6.00
A7238.0X79	8.00	0.3150	24.0	79.0	8.00
A7238.0X117	8.00	0.3150	24.0	117.0	8.00



A119



Foret court à double pointe en HSS, finition avec traitement vapeur

Foret court à double extrémité conçu pour percer des trous dans la tôle. Possibilité d'utiliser les deux extrémités, ce qui double la durée de vie de l'outil. Pointe conventionnelle à 120° pour faciliter l'auto-centrage. Convient pour percer de nombreux matériaux. La finition avec traitement vapeur retient le fluide de coupe et empêche le collage des copeaux sur l'outil.

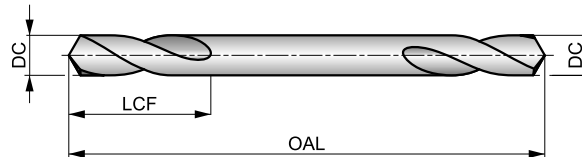

HSS	DIN 1897	1.25xD
120°	ST	
20-35°	R	DC h8

Adéquation du groupe de matériaux de la pièce, valeurs de départ pour la vitesse de coupe (m/min) et code Alpha d'avance. Les tableaux d'avances par tour se trouvent à partir de la page 175.

P1.1 ■ 31 C	P1.2 ■ 34 C	P1.3 ■ 35 C	P2.1 ■ 26 C	P2.2 ■ 23 C	P2.3 ■ 20 C	P3.1 ■ 12 C	P3.2 ■ 9 C	P3.3 ■ 8 C	P4.1 ■ 7 C	P4.2 ■ 6 C	P4.3 ■ 5 A	M1.1 ■ 21 A	M1.2 ■ 17 A
M2.1 ■ 18 A	M2.2 ■ 15 A	M3.1 ■ 8 C	M3.2 ■ 7 C	M3.3 ■ 6 C	M4.1 ■ 10 A	N1.1 ■ 33 C	N1.2 ■ 25 C	N1.3 ■ 17 C	N2.1 ■ 46 C	N2.2 ■ 42 C	N2.3 ■ 30 C	N3.1 ■ 56 C	N3.2 ■ 33 C
N3.3 ■ 17 A	N4.1 ■ 30 I	N4.2 ■ 35 C	S1.1 ■ 27 A	S1.2 ■ 12 A	S1.3 ■ 7 A	S2.1 ■ 5 C	S2.2 ■ 4 C	S3.1 ■ 4 C	S3.2 ■ 3 C	S4.1 ■ 3 C	S4.2 ■ 2 C		

Foret pour perçage de tôles.

Produit	DC	DC	LCF	OAL	DCON MS
	(mm)	(inch)	(mm)	(mm)	(mm)
A1193.3	3.30	0.1299	11.0	49.0	3.30
A1193.6	3.60	0.1417	12.0	52.0	3.60
A1194.1	4.10	0.1614	14.0	55.0	4.10
A1194.2	4.20	0.1654	14.0	55.0	4.20
A1194.9	4.90	0.1929	17.0	62.0	4.90
A1195.1	5.10	0.2008	17.0	62.0	5.10



A122



Foret à pointer en HSS, finition brillante

Foret utilisable pour créer un trou dans le matériau à percer afin de s'assurer que le point de départ est précis. Conçu avec un angle de pointe de 90° ou 120°, ce qui vous donne deux options de pointage. Finition de surface brillante. Convient pour le perçage de nombreux matériaux.

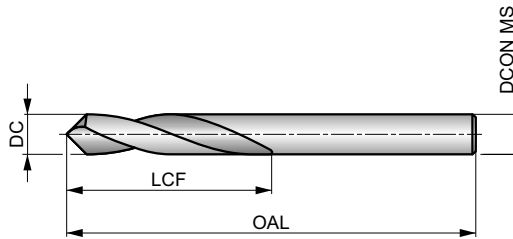

HSS	DIN 1897	1xD
90°/120°	Bright	
λ 20-35°	R	DC h8

Adéquation du groupe de matériaux de la pièce, valeurs de départ pour la vitesse de coupe (m/min) et code Alpha d'avance. Les tableaux d'avances par tour se trouvent à partir de la page 175.

P1.1 ■ 36 E	P1.2 ■ 40 E	P1.3 ■ 41 E	P2.1 ■ 31 E	P2.2 ■ 27 C	P2.3 ■ 24 C	P3.1 ■ 21 C	P3.2 ■ 17 C	P3.3 ■ 14 C	P4.1 ■ 12 C	P4.2 ■ 10 C	P4.3 ■ 9 B	M1.1 ■ 22 C	M1.2 ■ 19 C
M2.1 ■ 20 C	M2.2 ■ 16 C	M3.1 ■ 10 D	M3.2 ■ 9 D	M3.3 ■ 8 D	M4.1 ■ 10 B	K1.1 ■ 32 E	K1.2 ■ 24 C	K1.3 ■ 18 C	K2.1 ■ 25 C	K2.2 ■ 20 C	K2.3 ■ 16 B	K3.1 ■ 22 C	K3.2 ■ 17 C
K3.3 ■ 13 B	K4.1 ■ 20 C	K4.2 ■ 15 C	K4.3 ■ 11 B	K4.4 ■ 10 B	K4.5 ■ 8 B	K5.1 ■ 23 C	K5.2 ■ 17 C	K5.3 ■ 13 B	N1.1 ■ 33 E	N1.2 ■ 25 E	N1.3 ■ 17 E	N2.1 ■ 46 D	N2.2 ■ 42 D
N2.3 ■ 30 D	N3.1 ■ 56 D	N3.2 ■ 33 E	N3.3 ■ 17 D	N4.1 ■ 30 F	N4.2 ■ 35 E	N4.3 ■ 17 D	S1.1 ■ 27 C	S1.2 ■ 12 B	S1.3 ■ 7 A	S2.1 ■ 11 C	S2.2 ■ 6 A	S3.1 ■ 8 C	S3.2 ■ 4 A
S4.1 ■ 6 C	S4.2 ■ 3 A												

Produit	DC	DC	LCF	OAL	DCON MS
	(mm)	(inch)			
A1226.0X90	6.00	0.2362	30.0	66.0	6.00
A1226.0X120	6.00	0.2362	30.0	66.0	6.00
A1228.0X90	8.00	0.3150	33.0	79.0	8.00
A1228.0X120	8.00	0.3150	33.0	79.0	8.00
A12210.0X90	10.00	0.3937	35.0	89.0	10.00
A12210.0X120	10.00	0.3937	35.0	89.0	10.00
A12212.0X90	12.00	0.4724	40.0	102.0	12.00
A12212.0X120	12.00	0.4724	40.0	102.0	12.00
A12216.0X90	16.00	0.6299	40.0	115.0	16.00
A12216.0X120	16.00	0.6299	40.0	115.0	16.00
A12220.0X90	20.00	0.7874	55.0	131.0	20.00
A12220.0X120	20.00	0.7874	55.0	131.0	20.00



A123



Foret extra-court en HSS, finition avec traitement vapeur, pour tôle

Foret spécialement conçu pour le perçage des matériaux fins et de la tôle. Sa pointe à 120° et sa finition avec traitement vapeur empêche le matériau de la pièce de coller aux arêtes de coupe, ce qui donne une meilleure finition du trou et un diamètre plus précis. Convient pour le perçage dans de nombreux matériaux.

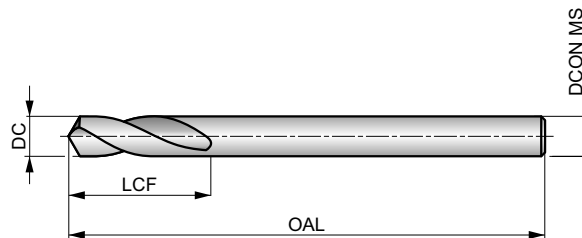

HSS	DIN 1897	1.5×D
120°	ST	
λ 20-35°	R	DC h8

Adéquation du groupe de matériaux de la pièce, valeurs de départ pour la vitesse de coupe (m/min) et code Alpha d'avance. Les tableaux d'avances par tour se trouvent à partir de la page 175.

P1.1 ■ 36 E	P1.2 ■ 40 E	P1.3 ■ 41 E	P2.1 ■ 31 E	P2.2 ■ 27 C	P2.3 ■ 24 C	P3.1 ■ 21 C	P3.2 ■ 17 C	P3.3 ■ 14 C	P4.1 ■ 12 C	P4.2 ■ 10 C	P4.3 ■ 9 B	M1.1 ■ 22 C	M1.2 ■ 19 C
M2.1 ■ 20 C	M2.2 ■ 16 C	M3.1 ■ 10 D	M3.2 ■ 9 D	M3.3 ■ 8 D	M4.1 ■ 10 B	N1.1 ■ 33 E	N1.2 ■ 25 E	N1.3 ■ 17 E	N2.1 ■ 46 D	N2.2 ■ 42 D	N2.3 ■ 30 D	N3.1 ■ 56 D	N3.2 ■ 33 E
N3.3 ■ 17 D	N4.1 ■ 30 F	N4.2 ■ 35 E	N4.3 ■ 17 D	S1.1 ■ 27 C	S1.2 ■ 12 B	S1.3 ■ 7 A	S2.1 ■ 11 C	S2.2 ■ 6 A	S3.1 ■ 8 C	S3.2 ■ 4 A	S4.1 ■ 6 C	S4.2 ■ 3 A	

Foret pour perçage de tôles.

Produit	DC	DC	DC	LCF	OAL	DCON MS
	(inch)	(mm)	(inch)	(mm)	(mm)	(mm)
A1233/32S	3/32	2.38	0.0937	14.0	43.0	2.38
A1232.5S	–	2.50	0.0984	14.0	43.0	2.50
A1233.0S	–	3.00	0.1181	16.0	46.0	3.00
A1231/8S	1/8	3.18	0.1252	18.0	49.0	3.18
A1233.2S	–	3.20	0.1260	18.0	49.0	3.20
A1233.3S	–	3.30	0.1299	18.0	49.0	3.30
A1233.5S	–	3.50	0.1378	18.0	52.0	3.50
A1233.7S	–	3.70	0.1457	18.0	52.0	3.70
A1235/32S	5/32	3.97	0.1563	18.0	55.0	3.97
A1234.0S	–	4.00	0.1575	18.0	55.0	4.00
A1234.1S	–	4.10	0.1614	18.0	55.0	4.10
A1234.2S	–	4.20	0.1654	18.0	55.0	4.20
A1234.5S	–	4.50	0.1772	18.0	58.0	4.50
A1233/16S	3/16	4.76	0.1875	18.0	62.0	4.76
A1234.8S	–	4.80	0.1890	18.0	62.0	4.80
A1234.9S	–	4.90	0.1929	18.0	62.0	4.90
A1235.0S	–	5.00	0.1969	18.0	62.0	5.00
A1235.5S	–	5.50	0.2165	18.0	66.0	5.50
A1237/32S	7/32	5.56	0.2188	18.0	66.0	5.56
A1236.0S	–	6.00	0.2362	18.0	66.0	6.00
A1231/4S	1/4	6.35	0.2500	19.0	70.0	6.35



A120



Foret extra-court en HSS, finition avec traitement vapeur

Foret polyvalent avec finition traitement vapeur. Sa pointe à 135° avec affûtage en croix réduit les forces lors du perçage et empêche le foret de dérapier sur la surface du matériau. La finition avec traitement vapeur retient le liquide de coupe et empêche le collage des copeaux sur l'outil. Convient pour le perçage manuel et mécanique de nombreux matériaux.

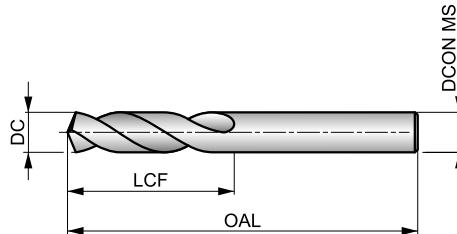

HSS	DIN 1897	2.5×D
135°	ST	
λ 20-35°	R	DC h8

Adéquation du groupe de matériaux de la pièce, valeurs de départ pour la vitesse de coupe (m/min) et code Alpha d'avance. Les tableaux d'avances par tour se trouvent à partir de la page 175.

P1.1 ■ 36 J	P1.2 ■ 40 J	P1.3 ■ 41 J	P2.1 ■ 31 J	P2.2 ■ 27 G	P2.3 ■ 24 F	P3.1 ■ 21 G	P3.2 ■ 17 G	P3.3 ■ 14 F	P4.1 ■ 12 G	P4.2 ■ 10 F	P4.3 ■ 9 E	M1.1 ■ 22 F	M1.2 ■ 19 F
M2.1 ■ 20 F	M2.2 ■ 16 F	M3.1 ■ 10 H	M3.2 ■ 9 H	M3.3 ■ 8 H	M4.1 ■ 10 D	K1.1 ■ 32 J	K1.2 ■ 24 G	K1.3 ■ 18 G	K2.1 ■ 25 F	K2.2 ■ 20 F	K2.3 ■ 16 F	K3.1 ■ 22 F	K3.2 ■ 17 F
K3.3 ■ 13 F	K4.1 ■ 20 F	K4.2 ■ 15 F	K4.3 ■ 11 F	K4.4 ■ 10 F	K4.5 ■ 8 F	K5.1 ■ 23 F	K5.2 ■ 17 F	K5.3 ■ 13 F	N1.1 ■ 33 K	N1.2 ■ 25 K	N1.3 ■ 17 J	N2.1 ■ 46 I	N2.2 ■ 42 I
N2.3 ■ 30 I	N3.1 ■ 64 I	N3.2 ■ 38 J	N3.3 ■ 19 H	N4.1 ■ 30 K	N4.2 ■ 35 I	N4.3 ■ 17 G	S1.1 ■ 27 G	S1.2 ■ 16 E	S1.3 ■ 8 C	S2.1 ■ 11 F	S2.2 ■ 6 B	S3.1 ■ 8 F	S3.2 ■ 4 B
S4.1 ■ 6 F	S4.2 ■ 3 B												

DC <= 1mm Brillant; avec pointe 118° pour DC <= 2.9mm et >= 13.0mm.

Produit	DC	DC	DC	LCF	OAL	DCON MS
	(inch)	(mm)	(inch)	(mm)	(mm)	(mm)
A120.5	-	0.50	0.0197	3.0	20.0	0.50
A120.6	-	0.60	0.0236	3.5	21.0	0.60
A120.7	-	0.70	0.0276	4.5	23.0	0.70
A1201/32	1/32	0.79	0.0313	5.0	24.0	0.79
A120.8	-	0.80	0.0315	5.0	24.0	0.80
A120.9	-	0.90	0.0354	5.5	25.0	0.90
A1201.0	-	1.00	0.0394	6.0	26.0	1.00
A1201.1	-	1.10	0.0433	7.0	28.0	1.10
A1203/64	3/64	1.19	0.0469	8.0	30.0	1.19
A1201.2	-	1.20	0.0472	8.0	30.0	1.20
A1201.3	-	1.30	0.0512	8.0	30.0	1.30
A1201.4	-	1.40	0.0551	9.0	32.0	1.40
A1201.5	-	1.50	0.0591	9.0	32.0	1.50
A1201/16	1/16	1.59	0.0625	10.0	34.0	1.59
A1201.6	-	1.60	0.0630	10.0	34.0	1.60
A1201.7	-	1.70	0.0669	10.0	34.0	1.70
A1201.8	-	1.80	0.0709	11.0	36.0	1.80
A1201.9	-	1.90	0.0748	11.0	36.0	1.90
A1205/64	5/64	1.98	0.0781	12.0	38.0	1.98
A1202.0	-	2.00	0.0787	12.0	38.0	2.00
A1202.1	-	2.10	0.0827	12.0	38.0	2.10
A1202.2	-	2.20	0.0866	13.0	40.0	2.20
A1202.25	-	2.25	0.0886	13.0	40.0	2.25

Produit	DC	DC	DC	LCF	OAL	DCON MS
	(inch)	(mm)	(inch)	(mm)	(mm)	(mm)
A1202.3	-	2.30	0.0906	13.0	40.0	2.30
A1203/32	3/32	2.38	0.0938	14.0	43.0	2.38
A1202.4	-	2.40	0.0945	14.0	43.0	2.40
A1202.5	-	2.50	0.0984	14.0	43.0	2.50
A1202.6	-	2.60	0.1024	14.0	43.0	2.60
A1202.65	-	2.65	0.1043	14.0	43.0	2.65
A1202.7	-	2.70	0.1063	16.0	46.0	2.70
A1207/64	7/64	2.78	0.1094	16.0	46.0	2.78
A1202.8	-	2.80	0.1102	16.0	46.0	2.80
A1202.9	-	2.90	0.1142	16.0	46.0	2.90
A1203.0	-	3.00	0.1181	16.0	46.0	3.00
A1203.1	-	3.10	0.1220	18.0	49.0	3.10
A1201/8	1/8	3.18	0.1252	18.0	49.0	3.18
A1203.2	-	3.20	0.1260	18.0	49.0	3.20
A1203.25	-	3.25	0.1280	18.0	49.0	3.25
A1203.3	-	3.30	0.1299	18.0	49.0	3.30
A1203.4	-	3.40	0.1339	20.0	52.0	3.40
A1203.5	-	3.50	0.1378	20.0	52.0	3.50
A1209/64	9/64	3.57	0.1406	20.0	52.0	3.57
A1203.6	-	3.60	0.1417	20.0	52.0	3.60
A1203.7	-	3.70	0.1457	20.0	52.0	3.70
A1203.8	-	3.80	0.1496	22.0	55.0	3.80
A1203.9	-	3.90	0.1535	22.0	55.0	3.90



Produit	DC	DC	DC	LCF	OAL	DCON MS
	(inch)	(mm)	(inch)	(mm)	(mm)	(mm)
A1205/32	5/32	3.97	0.1563	22.0	55.0	3.97
A1204.0	–	4.00	0.1575	22.0	55.0	4.00
A1204.1	–	4.10	0.1614	22.0	55.0	4.10
A1204.2	–	4.20	0.1654	22.0	55.0	4.20
A1204.3	–	4.30	0.1693	24.0	58.0	4.30
A12011/64	11/64	4.37	0.1719	24.0	58.0	4.37
A1204.4	–	4.40	0.1732	24.0	58.0	4.40
A1204.5	–	4.50	0.1772	24.0	58.0	4.50
A1204.6	–	4.60	0.1811	24.0	58.0	4.60
A1204.7	–	4.70	0.1850	24.0	58.0	4.70
A1203/16	3/16	4.76	0.1875	26.0	62.0	4.76
A1204.8	–	4.80	0.1890	26.0	62.0	4.80
A1204.9	–	4.90	0.1929	26.0	62.0	4.90
A1205.0	–	5.00	0.1969	26.0	62.0	5.00
A1205.1	–	5.10	0.2008	26.0	62.0	5.10
A12013/64	13/64	5.16	0.2031	26.0	62.0	5.16
A1205.2	–	5.20	0.2047	26.0	62.0	5.20
A1205.3	–	5.30	0.2087	26.0	62.0	5.30
A1205.4	–	5.40	0.2126	28.0	66.0	5.40
A1205.5	–	5.50	0.2165	28.0	66.0	5.50
A1207/32	7/32	5.56	0.2188	28.0	66.0	5.56
A1205.6	–	5.60	0.2205	28.0	66.0	5.60
A1205.7	–	5.70	0.2244	28.0	66.0	5.70
A1205.8	–	5.80	0.2283	28.0	66.0	5.80
A1205.9	–	5.90	0.2323	28.0	66.0	5.90
A12015/64	15/64	5.95	0.2344	28.0	66.0	5.95
A1206.0	–	6.00	0.2362	28.0	66.0	6.00
A1206.1	–	6.10	0.2402	31.0	70.0	6.10
A1206.2	–	6.20	0.2441	31.0	70.0	6.20
A1206.3	–	6.30	0.2480	31.0	70.0	6.30
A1201/4	1/4	6.35	0.2500	31.0	70.0	6.35
A1206.4	–	6.40	0.2520	31.0	70.0	6.40
A1206.5	–	6.50	0.2559	31.0	70.0	6.50
A1206.6	–	6.60	0.2598	31.0	70.0	6.60
A1206.7	–	6.70	0.2638	31.0	70.0	6.70
A1206.8	–	6.80	0.2677	34.0	74.0	6.80
A1206.9	–	6.90	0.2717	34.0	74.0	6.90
A1207.0	–	7.00	0.2756	34.0	74.0	7.00
A1207.1	–	7.10	0.2795	34.0	74.0	7.10
A1209/32	9/32	7.14	0.2813	34.0	74.0	7.14
A1207.2	–	7.20	0.2835	34.0	74.0	7.20
A1207.3	–	7.30	0.2874	34.0	74.0	7.30
A1207.4	–	7.40	0.2913	34.0	74.0	7.40
A1207.5	–	7.50	0.2953	34.0	74.0	7.50
A1207.6	–	7.60	0.2992	37.0	79.0	7.60
A1207.7	–	7.70	0.3031	37.0	79.0	7.70
A1207.8	–	7.80	0.3071	37.0	79.0	7.80
A1207.9	–	7.90	0.3110	37.0	79.0	7.90
A1205/16	5/16	7.94	0.3125	37.0	79.0	7.94
A1208.0	–	8.00	0.3150	37.0	79.0	8.00
A1208.1	–	8.10	0.3189	37.0	79.0	8.10
A1208.2	–	8.20	0.3228	37.0	79.0	8.20
A1208.3	–	8.30	0.3268	37.0	79.0	8.30
A1208.4	–	8.40	0.3307	37.0	79.0	8.40
A1208.5	–	8.50	0.3346	37.0	79.0	8.50
A1208.6	–	8.60	0.3386	40.0	84.0	8.60
A1208.7	–	8.70	0.3425	40.0	84.0	8.70
A12011/32	11/32	8.73	0.3438	40.0	84.0	8.73
A1208.8	–	8.80	0.3465	40.0	84.0	8.80
A1208.9	–	8.90	0.3504	40.0	84.0	8.90
A1209.0	–	9.00	0.3543	40.0	84.0	9.00
A1209.1	–	9.10	0.3583	40.0	84.0	9.10
A1209.2	–	9.20	0.3622	40.0	84.0	9.20
A1209.3	–	9.30	0.3661	40.0	84.0	9.30
A1209.4	–	9.40	0.3701	40.0	84.0	9.40

Produit	DC	DC	DC	LCF	OAL	DCON MS
	(inch)	(mm)	(inch)	(mm)	(mm)	(mm)
A1209.5	–	9.50	0.3740	40.0	84.0	9.50
A1203/8	3/8	9.52	0.3750	43.0	89.0	9.52
A1209.6	–	9.60	0.3780	43.0	89.0	9.60
A1209.7	–	9.70	0.3819	43.0	89.0	9.70
A1209.8	–	9.80	0.3858	43.0	89.0	9.80
A1209.9	–	9.90	0.3898	43.0	89.0	9.90
A12010.0	–	10.00	0.3937	43.0	89.0	10.00
A12010.1	–	10.10	0.3976	43.0	89.0	10.10
A12010.2	–	10.20	0.4016	43.0	89.0	10.20
A12010.3	–	10.30	0.4055	43.0	89.0	10.30
A12013/32	13/32	10.32	0.4063	43.0	89.0	10.32
A12010.4	–	10.40	0.4094	43.0	89.0	10.40
A12010.5	–	10.50	0.4134	43.0	89.0	10.50
A12010.6	–	10.60	0.4173	43.0	89.0	10.60
A12010.7	–	10.70	0.4213	47.0	95.0	10.70
A12010.8	–	10.80	0.4252	47.0	95.0	10.80
A12010.9	–	10.90	0.4291	47.0	95.0	10.90
A12011.0	–	11.00	0.4331	47.0	95.0	11.00
A12011.1	–	11.10	0.4370	47.0	95.0	11.10
A1207/16	7/16	11.11	0.4375	47.0	95.0	11.11
A12011.2	–	11.20	0.4409	47.0	95.0	11.20
A12011.3	–	11.30	0.4449	47.0	95.0	11.30
A12011.5	–	11.50	0.4528	47.0	95.0	11.50
A12011.6	–	11.60	0.4567	47.0	95.0	11.60
A12011.7	–	11.70	0.4606	47.0	95.0	11.70
A12011.8	–	11.80	0.4646	47.0	95.0	11.80
A12011.9	–	11.90	0.4685	51.0	102.0	11.90
A12012.0	–	12.00	0.4724	51.0	102.0	12.00
A12012.1	–	12.10	0.4764	51.0	102.0	12.10
A12012.2	–	12.20	0.4803	51.0	102.0	12.20
A12012.5	–	12.50	0.4921	51.0	102.0	12.50
A1201/2	1/2	12.70	0.5000	51.0	102.0	12.70
A12013.0	–	13.00	0.5118	51.0	102.0	13.00
A12013.5	–	13.50	0.5315	54.0	107.0	13.50
A12014.0	–	14.00	0.5512	54.0	107.0	14.00
A1209/16	9/16	14.29	0.5625	56.0	111.0	14.29
A12014.5	–	14.50	0.5709	56.0	111.0	14.50
A12015.0	–	15.00	0.5906	56.0	111.0	15.00
A12015.5	–	15.50	0.6102	58.0	115.0	15.50
A1205/8	5/8	15.88	0.6250	58.0	115.0	15.88
A12016.0	–	16.00	0.6299	58.0	115.0	16.00
A12016.5	–	16.50	0.6496	60.0	119.0	16.50
A12017.0	–	17.00	0.6693	60.0	119.0	17.00
A12011/16	11/16	17.46	0.6875	62.0	123.0	17.46
A12017.5	–	17.50	0.6890	62.0	123.0	17.50
A12018.0	–	18.00	0.7087	62.0	123.0	18.00
A12018.5	–	18.50	0.7283	64.0	127.0	18.50
A12019.0	–	19.00	0.7480	64.0	127.0	19.00
A1203/4	3/4	19.05	0.7500	66.0	131.0	19.05
A12019.5	–	19.50	0.7677	66.0	131.0	19.50
A12020.0	–	20.00	0.7874	66.0	131.0	20.00
A12020.5	–	20.50	0.8071	68.0	136.0	20.50
A12013/16	13/16	20.64	0.8125	68.0	136.0	20.64
A12021.0	–	21.00	0.8268	68.0	136.0	21.00
A12022.0	–	22.00	0.8661	70.0	141.0	22.00
A1207/8	7/8	22.22	0.8750	70.0	141.0	22.22
A12023.0	–	23.00	0.9055	72.0	146.0	23.00
A12015/16	15/16	23.81	0.9375	75.0	151.0	23.81
A12024.0	–	24.00	0.9449	75.0	151.0	24.00
A12025.0	–	25.00	0.9843	75.0	151.0	25.00



A022

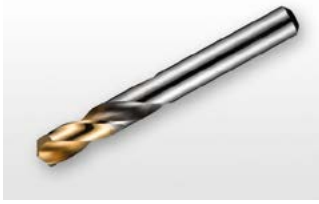

Foret extra-court en HSS, revêtement TiN en pointe

Foret polyvalent doté d'une pointe spéciale à 135° avec affûtage en croix conçue pour faciliter l'auto-centrage lors du perçage à la main et sur machines, ce qui permet d'obtenir un trou plus précis et une meilleure qualité de finition. Convient pour le perçage de nombreux matériaux. Le revêtement TiN en pointe améliore les performances et prolonge la durée de vie de l'outil.

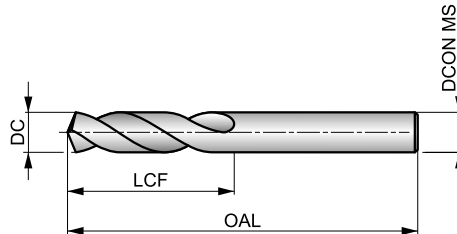

HSS	DIN ANSI	2.5×D
135°	TiN-Tip	
λ 20-35°	R	DC h8

Adéquation du groupe de matériaux de la pièce, valeurs de départ pour la vitesse de coupe (m/min) et code Alpha d'avance. Les tableaux d'avances par tour se trouvent à partir de la page 175.

P1.1 ■ 33 K	P1.2 ■ 37 K	P1.3 ■ 38 K	P2.1 ■ 28 K	P2.2 ■ 25 I	P2.3 ■ 22 G	P3.1 ■ 24 H	P3.2 ■ 19 H	P3.3 ■ 16 G	P4.1 ■ 14 H	P4.2 ■ 12 G	P4.3 ▣ 10 E	M1.1 ■ 21 G	M1.2 ■ 17 G
M2.1 ■ 18 G	M2.2 ■ 15 G	M3.1 ▣ 9 I	M3.2 ▣ 8 I	M3.3 ▣ 7 I	M4.1 ▣ 9 E	K1.1 ■ 32 K	K1.2 ■ 24 I	K1.3 ■ 18 I	K2.1 ■ 25 G	K2.2 ■ 20 G	K2.3 ▣ 16 G	K3.1 ■ 22 G	K3.2 ■ 17 G
K3.3 ▣ 13 G	K4.1 ■ 20 G	K4.2 ■ 15 G	K4.3 ▣ 11 G	K4.4 ▣ 10 G	K4.5 ▣ 8 G	K5.1 ■ 23 G	K5.2 ■ 17 G	K5.3 ▣ 13 G	N1.1 ■ 40 F	N1.2 ■ 30 F	N1.3 ■ 20 K	N2.1 ■ 49 J	N2.2 ■ 44 J
N2.3 ■ 32 J	N3.1 ▣ 64 I	N3.2 ▣ 38 K	N3.3 ▣ 19 H	N4.1 ▣ 30 K	N4.2 ▣ 35 I	N4.3 ▣ 17 G	S1.1 ■ 25 I	S1.2 ▣ 14 F	S1.3 ▣ 8 C	S2.1 ▣ 11 F	S2.2 ▣ 6 B	S3.1 ▣ 8 F	S3.2 ▣ 4 B
S4.1 ▣ 6 F	S4.2 ▣ 3 B												

DC < 2mm Brillant; DC >= 2mm revêtu TiN en pointe avec affûtage en croix.
Les produits de cette série sont également disponibles en coffret. Voir A088.

Produit	DC (inch)	DC (mm)	DC (inch)	LCF (mm)	OAL (mm)	DCON MS (mm)
A022.5	—	0.50	0.0197	3.0	20.0	0.50
A022.6	—	0.60	0.0236	3.5	21.0	0.60
A022.7	—	0.70	0.0276	4.5	23.0	0.70
A0221/32	1/32	0.79	0.0313	13.0	35.0	0.79
A022.8	—	0.80	0.0315	5.0	24.0	0.80
A022.9	—	0.90	0.0354	5.5	25.0	0.90
A0221.0	—	1.00	0.0394	6.0	26.0	1.00
A0221.1	—	1.10	0.0433	7.0	28.0	1.10
A0223/64	3/64	1.19	0.0469	13.0	35.0	1.19
A0221.2	—	1.20	0.0472	8.0	30.0	1.20
A0221.3	—	1.30	0.0512	8.0	30.0	1.30
A0221.4	—	1.40	0.0551	9.0	32.0	1.40
A0221.5	—	1.50	0.0591	9.0	32.0	1.50
A0221/16	1/16	1.59	0.0625	16.0	41.0	1.59
A0221.6	—	1.60	0.0630	10.0	34.0	1.60
A0221.7	—	1.70	0.0669	10.0	34.0	1.70
A0221.8	—	1.80	0.0709	11.0	36.0	1.80
A0221.9	—	1.90	0.0748	11.0	36.0	1.90
A0225/64	5/64	1.98	0.0781	17.0	43.0	1.98
A0222.0	—	2.00	0.0787	12.0	38.0	2.00
A0222.1	—	2.10	0.0827	12.0	38.0	2.10
A0222.2	—	2.20	0.0866	13.0	40.0	2.20

Produit	DC (inch)	DC (mm)	DC (inch)	LCF (mm)	OAL (mm)	DCON MS (mm)
A0222.25	—	2.25	0.0886	13.0	40.0	2.25
A0222.3	—	2.30	0.0906	13.0	40.0	2.30
A0223/32	3/32	2.38	0.0938	20.0	45.0	2.38
A0222.4	—	2.40	0.0945	14.0	43.0	2.40
A0222.5	—	2.50	0.0984	14.0	43.0	2.50
A0222.6	—	2.60	0.1024	14.0	43.0	2.60
A0222.65	—	2.65	0.1043	14.0	43.0	2.65
A0222.7	—	2.70	0.1063	16.0	46.0	2.70
A0227/64	7/64	2.78	0.1094	22.0	47.0	2.78
A0222.8	—	2.80	0.1102	16.0	46.0	2.80
A0222.9	—	2.90	0.1142	16.0	46.0	2.90
A0223.0	—	3.00	0.1181	16.0	46.0	3.00
A0223.1	—	3.10	0.1220	18.0	49.0	3.10
A0221/8	1/8	3.18	0.1250	23.0	49.0	3.18
A0223.2	—	3.20	0.1260	18.0	49.0	3.20
A0223.25	—	3.25	0.1280	18.0	49.0	3.25
A0223.3	—	3.30	0.1299	18.0	49.0	3.30
A0223.4	—	3.40	0.1339	20.0	52.0	3.40
A0223.5	—	3.50	0.1378	20.0	52.0	3.50
A0229/64	9/64	3.57	0.1406	25.0	50.0	3.57
A0223.6	—	3.60	0.1417	20.0	52.0	3.60
A0223.7	—	3.70	0.1457	20.0	52.0	3.70



Produit	DC	DC	DC	LCF	OAL	DCON MS
	(inch)	(mm)	(inch)	(mm)	(mm)	(mm)
A0223.8	—	3.80	0.1496	22.0	55.0	3.80
A0223.9	—	3.90	0.1535	22.0	55.0	3.90
A0225/32	5/32	3.97	0.1563	26.0	53.0	3.97
A0224.0	—	4.00	0.1575	22.0	55.0	4.00
A0224.1	—	4.10	0.1614	22.0	55.0	4.10
A0224.2	—	4.20	0.1654	22.0	55.0	4.20
A0224.3	—	4.30	0.1693	24.0	58.0	4.30
A02211/64	11/64	4.37	0.1719	28.0	55.0	4.37
A0224.4	—	4.40	0.1732	24.0	58.0	4.40
A0224.5	—	4.50	0.1772	24.0	58.0	4.50
A0224.6	—	4.60	0.1811	24.0	58.0	4.60
A0224.7	—	4.70	0.1850	24.0	58.0	4.70
A0223/16	3/16	4.76	0.1875	30.0	57.0	4.76
A0224.8	—	4.80	0.1890	26.0	62.0	4.80
A0224.9	—	4.90	0.1929	26.0	62.0	4.90
A0225.0	—	5.00	0.1969	26.0	62.0	5.00
A0225.1	—	5.10	0.2008	26.0	62.0	5.10
A02213/64	13/64	5.16	0.2031	31.0	58.0	5.16
A0225.2	—	5.20	0.2047	26.0	62.0	5.20
A0225.3	—	5.30	0.2087	26.0	62.0	5.30
A0225.4	—	5.40	0.2126	28.0	66.0	5.40
A0225.5	—	5.50	0.2165	28.0	66.0	5.50
A0227/32	7/32	5.56	0.2188	33.0	61.0	5.56
A0225.6	—	5.60	0.2205	28.0	66.0	5.60
A0225.7	—	5.70	0.2244	28.0	66.0	5.70
A0225.8	—	5.80	0.2283	28.0	66.0	5.80
A0225.9	—	5.90	0.2323	28.0	66.0	5.90
A02215/64	15/64	5.95	0.2344	34.0	63.0	5.95
A0226.0	—	6.00	0.2362	28.0	66.0	6.00
A0226.1	—	6.10	0.2402	31.0	70.0	6.10
A0226.2	—	6.20	0.2441	31.0	70.0	6.20
A0226.3	—	6.30	0.2480	31.0	70.0	6.30
A0221/4	1/4	6.35	0.2500	36.0	65.0	6.35
A0226.4	—	6.40	0.2520	31.0	70.0	6.40
A0226.5	—	6.50	0.2559	31.0	70.0	6.50
A0226.6	—	6.60	0.2598	31.0	70.0	6.60
A0226.7	—	6.70	0.2638	31.0	70.0	6.70
A0226.8	—	6.80	0.2677	34.0	74.0	6.80
A0226.9	—	6.90	0.2717	34.0	74.0	6.90
A0227.0	—	7.00	0.2756	34.0	74.0	7.00
A0227.1	—	7.10	0.2795	34.0	74.0	7.10
A0229/32	9/32	7.14	0.2813	40.0	70.0	7.14
A0227.2	—	7.20	0.2835	34.0	74.0	7.20
A0227.3	—	7.30	0.2874	34.0	74.0	7.30
A0227.4	—	7.40	0.2913	34.0	74.0	7.40
A0227.5	—	7.50	0.2953	34.0	74.0	7.50
A0227.6	—	7.60	0.2992	37.0	79.0	7.60
A0227.7	—	7.70	0.3031	37.0	79.0	7.70
A0227.8	—	7.80	0.3071	37.0	79.0	7.80
A0227.9	—	7.90	0.3110	37.0	79.0	7.90
A0225/16	5/16	7.94	0.3125	43.0	73.0	7.94
A0228.0	—	8.00	0.3150	37.0	79.0	8.00
A0228.1	—	8.10	0.3189	37.0	79.0	8.10
A0228.2	—	8.20	0.3228	37.0	79.0	8.20

Produit	DC	DC	DC	LCF	OAL	DCON MS
	(inch)	(mm)	(inch)	(mm)	(mm)	(mm)
A0228.3	—	8.30	0.3268	37.0	79.0	8.30
A0228.4	—	8.40	0.3307	37.0	79.0	8.40
A0228.5	—	8.50	0.3346	37.0	79.0	8.50
A0228.6	—	8.60	0.3386	40.0	84.0	8.60
A0228.7	—	8.70	0.3425	40.0	84.0	8.70
A02211/32	11/32	8.73	0.3438	45.0	78.0	8.73
A0228.8	—	8.80	0.3465	40.0	84.0	8.80
A0228.9	—	8.90	0.3504	40.0	84.0	8.90
A0229.0	—	9.00	0.3543	40.0	84.0	9.00
A0229.1	—	9.10	0.3583	40.0	84.0	9.10
A0229.2	—	9.20	0.3622	40.0	84.0	9.20
A0229.3	—	9.30	0.3661	40.0	84.0	9.30
A0229.4	—	9.40	0.3701	40.0	84.0	9.40
A0229.5	—	9.50	0.3740	40.0	84.0	9.50
A0223/8	3/8	9.52	0.3750	48.0	81.0	9.52
A0229.6	—	9.60	0.3780	43.0	89.0	9.60
A0229.7	—	9.70	0.3819	43.0	89.0	9.70
A0229.8	—	9.80	0.3858	43.0	89.0	9.80
A0229.9	—	9.90	0.3898	43.0	89.0	9.90
A02210.0	—	10.00	0.3937	43.0	89.0	10.00
A02210.1	—	10.10	0.3976	43.0	89.0	10.10
A02210.2	—	10.20	0.4016	43.0	89.0	10.20
A02210.3	—	10.30	0.4055	43.0	89.0	10.30
A02213/32	13/32	10.32	0.4063	51.0	86.0	10.32
A02210.4	—	10.40	0.4094	43.0	89.0	10.40
A02210.5	—	10.50	0.4134	43.0	89.0	10.50
A02210.6	—	10.60	0.4173	43.0	89.0	10.60
A02210.7	—	10.70	0.4213	47.0	95.0	10.70
A02210.8	—	10.80	0.4252	47.0	95.0	10.80
A02210.9	—	10.90	0.4291	47.0	95.0	10.90
A02211.0	—	11.00	0.4331	47.0	95.0	11.00
A02211.1	—	11.10	0.4370	47.0	95.0	11.10
A0227/16	7/16	11.11	0.4375	54.0	89.0	11.11
A02211.2	—	11.20	0.4409	47.0	95.0	11.20
A02211.3	—	11.30	0.4449	47.0	95.0	11.30
A02211.5	—	11.50	0.4528	47.0	95.0	11.50
A02211.6	—	11.60	0.4567	47.0	95.0	11.60
A02211.7	—	11.70	0.4606	47.0	95.0	11.70
A02211.8	—	11.80	0.4646	47.0	95.0	11.80
A02211.9	—	11.90	0.4685	51.0	102.0	11.90
A02212.0	—	12.00	0.4724	51.0	102.0	12.00
A02212.1	—	12.10	0.4764	51.0	102.0	12.10
A02212.2	—	12.20	0.4803	51.0	102.0	12.20
A02212.5	—	12.50	0.4921	51.0	102.0	12.50
A0221/2	1/2	12.70	0.5000	60.0	98.0	12.70
A02213.0	—	13.00	0.5118	51.0	102.0	13.00
A02213.5	—	13.50	0.5315	54.0	107.0	13.50
A02214.0	—	14.00	0.5512	54.0	107.0	14.00
A0229/16	9/16	14.29	0.5625	67.0	105.0	14.29
A02214.5	—	14.50	0.5709	56.0	111.0	14.50
A02215.0	—	15.00	0.5906	56.0	111.0	15.00
A02215.5	—	15.50	0.6102	58.0	115.0	15.50
A0225/8	5/8	15.88	0.6250	73.0	111.0	15.88
A02216.0	—	16.00	0.6299	58.0	115.0	16.00



A620



Foret extra-court en HSS-E (5% cobalt), finition avec traitement bronze

Foret avec un angle de pointe à 130° qui facilite l'auto-centrage et réduit les forces de coupe. La finition avec traitement bronze est une fine couche d'oxyde et c'est une indication pour le cobalt. Convient pour percer de nombreux matériaux. Ne doit pas être utilisé dans des appareils portatifs.

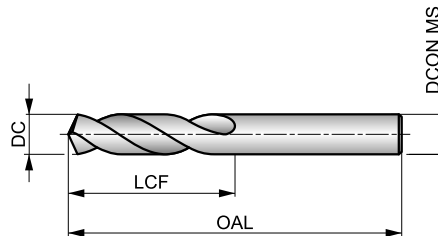

HSS-E	DIN 1897	2.5×D
130°	Bronze	
λ 20-35°	R	DC h8

Adéquation du groupe de matériaux de la pièce, valeurs de départ pour la vitesse de coupe (m/min) et code Alpha d'avance. Les tableaux d'avances par tour se trouvent à partir de la page 175.

P1.1 ■ 40 H	P1.2 ■ 45 H	P1.3 ■ 46 H	P2.1 ■ 34 H	P2.2 ■ 30 G	P2.3 ■ 27 F	P3.1 ■ 27 G	P3.2 ■ 21 G	P3.3 ■ 18 F	P4.1 ■ 16 G	P4.2 ■ 13 F	P4.3 ■ 11 E	M1.1 ■ 30 F	M1.2 ■ 26 F
M2.1 ■ 27 F	M2.2 ■ 22 F	M3.1 ■ 13 H	M3.2 ■ 11 H	M3.3 ■ 10 H	M4.1 ■ 15 D	K1.1 ■ 34 K	K1.2 ■ 25 F	K1.3 ■ 19 F	K2.1 ■ 27 F	K2.2 ■ 22 F	K2.3 ■ 18 F	K3.1 ■ 24 F	K3.2 ■ 18 F
K3.3 ■ 15 F	K4.1 ■ 22 F	K4.2 ■ 17 F	K4.3 ■ 12 F	K4.4 ■ 11 F	K4.5 ■ 9 F	K5.1 ■ 25 F	K5.2 ■ 19 F	K5.3 ■ 15 F	N1.1 ■ 40 K	N1.2 ■ 30 K	N1.3 ■ 20 J	N2.1 ■ 49 I	N2.2 ■ 44 I
N2.3 ■ 32 I	N3.1 ■ 68 J	N3.2 ■ 40 K	N3.3 ■ 20 I	N4.1 ■ 40 L	N4.2 ■ 32 K	N4.3 ■ 18 I	S1.1 ■ 30 G	S1.2 ■ 18 F	S1.3 ■ 10 C	S2.1 ■ 12 F	S2.2 ■ 8 C	S3.1 ■ 9 F	S3.2 ■ 6 C
S4.1 ■ 7 F	S4.2 ■ 5 C												

Produit	DC	DC	LCF	OAL	DCON MS
	(mm)	(inch)			
A6202.5	2.50	0.0984	14.0	43.0	2.50
A6202.6	2.60	0.1024	14.0	43.0	2.60
A6202.7	2.70	0.1063	16.0	46.0	2.70
A6202.8	2.80	0.1102	16.0	46.0	2.80
A6202.9	2.90	0.1142	16.0	46.0	2.90
A6203.0	3.00	0.1181	16.0	46.0	3.00
A6203.1	3.10	0.1220	18.0	49.0	3.10
A6203.2	3.20	0.1260	18.0	49.0	3.20
A6203.3	3.30	0.1299	18.0	49.0	3.30
A6203.4	3.40	0.1339	20.0	52.0	3.40
A6203.5	3.50	0.1378	20.0	52.0	3.50
A6203.6	3.60	0.1417	20.0	52.0	3.60
A6203.7	3.70	0.1457	20.0	52.0	3.70
A6203.8	3.80	0.1496	22.0	55.0	3.80
A6203.9	3.90	0.1535	22.0	55.0	3.90
A6204.0	4.00	0.1575	22.0	55.0	4.00
A6204.1	4.10	0.1614	22.0	55.0	4.10
A6204.2	4.20	0.1654	22.0	55.0	4.20
A6204.3	4.30	0.1693	24.0	58.0	4.30
A6204.4	4.40	0.1732	24.0	58.0	4.40
A6204.5	4.50	0.1772	24.0	58.0	4.50
A6204.6	4.60	0.1811	24.0	58.0	4.60
A6204.7	4.70	0.1850	24.0	58.0	4.70
A6204.8	4.80	0.1890	26.0	62.0	4.80

Produit	DC	DC	LCF	OAL	DCON MS
	(mm)	(inch)			
A6204.9	4.90	0.1929	26.0	62.0	4.90
A6205.0	5.00	0.1969	26.0	62.0	5.00
A6205.1	5.10	0.2008	26.0	62.0	5.10
A6205.2	5.20	0.2047	26.0	62.0	5.20
A6205.3	5.30	0.2087	26.0	62.0	5.30
A6205.4	5.40	0.2126	28.0	66.0	5.40
A6205.5	5.50	0.2165	28.0	66.0	5.50
A6205.6	5.60	0.2205	28.0	66.0	5.60
A6205.7	5.70	0.2244	28.0	66.0	5.70
A6205.8	5.80	0.2283	28.0	66.0	5.80
A6205.9	5.90	0.2323	28.0	66.0	5.90
A6206.0	6.00	0.2362	28.0	66.0	6.00
A6206.1	6.10	0.2402	31.0	70.0	6.10
A6206.2	6.20	0.2441	31.0	70.0	6.20
A6206.3	6.30	0.2480	31.0	70.0	6.30
A6206.4	6.40	0.2520	31.0	70.0	6.40
A6206.5	6.50	0.2559	31.0	70.0	6.50
A6206.6	6.60	0.2598	31.0	70.0	6.60
A6206.7	6.70	0.2638	31.0	70.0	6.70
A6206.8	6.80	0.2677	34.0	74.0	6.80
A6206.9	6.90	0.2717	34.0	74.0	6.90
A6207.0	7.00	0.2756	34.0	74.0	7.00
A6207.1	7.10	0.2795	34.0	74.0	7.10
A6207.2	7.20	0.2835	34.0	74.0	7.20



Produit	DC	DC	LCF	OAL	DCON MS
	(mm)	(inch)	(mm)	(mm)	(mm)
A6207.3	7.30	0.2874	34.0	74.0	7.30
A6207.4	7.40	0.2913	34.0	74.0	7.40
A6207.5	7.50	0.2953	34.0	74.0	7.50
A6207.6	7.60	0.2992	37.0	79.0	7.60
A6207.7	7.70	0.3031	37.0	79.0	7.70
A6207.8	7.80	0.3071	37.0	79.0	7.80
A6207.9	7.90	0.3110	37.0	79.0	7.90
A6208.0	8.00	0.3150	37.0	79.0	8.00
A6208.1	8.10	0.3189	37.0	79.0	8.10
A6208.2	8.20	0.3228	37.0	79.0	8.20
A6208.3	8.30	0.3268	37.0	79.0	8.30
A6208.4	8.40	0.3307	37.0	79.0	8.40
A6208.5	8.50	0.3346	37.0	79.0	8.50
A6208.6	8.60	0.3386	40.0	84.0	8.60
A6208.7	8.70	0.3425	40.0	84.0	8.70
A6208.8	8.80	0.3465	40.0	84.0	8.80
A6208.9	8.90	0.3504	40.0	84.0	8.90
A6209.0	9.00	0.3543	40.0	84.0	9.00
A6209.1	9.10	0.3583	40.0	84.0	9.10
A6209.2	9.20	0.3622	40.0	84.0	9.20

Produit	DC	DC	LCF	OAL	DCON MS
	(mm)	(inch)	(mm)	(mm)	(mm)
A6209.3	9.30	0.3661	40.0	84.0	9.30
A6209.4	9.40	0.3701	40.0	84.0	9.40
A6209.5	9.50	0.3740	40.0	84.0	9.50
A6209.6	9.60	0.3780	43.0	89.0	9.60
A6209.7	9.70	0.3819	43.0	89.0	9.70
A6209.8	9.80	0.3858	43.0	89.0	9.80
A6209.9	9.90	0.3898	43.0	89.0	9.90
A62010.0	10.00	0.3937	43.0	89.0	10.00
A62010.2	10.20	0.4016	43.0	89.0	10.20
A62010.3	10.30	0.4055	43.0	89.0	10.30
A62010.4	10.40	0.4094	43.0	89.0	10.40
A62010.5	10.50	0.4134	43.0	89.0	10.50
A62010.8	10.80	0.4252	47.0	95.0	10.80
A62011.0	11.00	0.4331	47.0	95.0	11.00
A62011.5	11.50	0.4528	47.0	95.0	11.50
A62012.0	12.00	0.4724	51.0	102.0	12.00
A62012.2	12.20	0.4803	51.0	102.0	12.20
A62012.5	12.50	0.4921	51.0	102.0	12.50
A62012.8	12.80	0.5039	51.0	102.0	12.80
A62013.0	13.00	0.5118	51.0	102.0	13.00



A117



Foret extra-court en HSS-E (8% cobalt), finition avec traitement bronze

Foret recommandé pour une utilisation dans des matériaux et des applications difficiles. sa pointe à 135° avec affûtage en croix facilite l'auto-centrage et réduit également les forces de coupe. Fiable pour produire un trou précis et une finition de qualité. La finition avec traitement bronze est une fine couche d'oxyde et c'est une indication pour le cobalt.

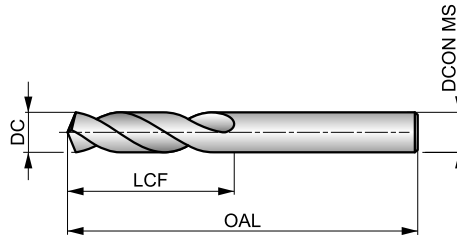

HSS-E	DIN 1897	2.5×D
135°	Bronze	
λ 20-35°	R	DC h8

Adéquation du groupe de matériaux de la pièce, valeurs de départ pour la vitesse de coupe (m/min) et code Alpha d'avance. Les tableaux d'avances par tour se trouvent à partir de la page 175.

P1.1 ■ 40 H	P1.2 ■ 45 H	P1.3 ■ 46 H	P2.1 ■ 34 H	P2.2 ■ 30 G	P2.3 ■ 27 F	P3.1 ■ 27 G	P3.2 ■ 21 G	P3.3 ■ 18 F	P4.1 ■ 16 G	P4.2 ■ 13 F	P4.3 ■ 11 E	M1.1 ■ 30 F	M1.2 ■ 26 F
M2.1 ■ 27 F	M2.2 ■ 22 F	M3.1 ■ 13 H	M3.2 ■ 11 H	M3.3 ■ 10 H	M4.1 ■ 15 D	K1.1 ■ 34 K	K1.2 ■ 25 F	K1.3 ■ 19 F	K2.1 ■ 27 F	K2.2 ■ 22 F	K2.3 ■ 18 F	K3.1 ■ 24 F	K3.2 ■ 18 F
K3.3 ■ 15 F	K4.1 ■ 22 F	K4.2 ■ 17 F	K4.3 ■ 12 F	K4.4 ■ 11 F	K4.5 ■ 9 F	K5.1 ■ 25 F	K5.2 ■ 19 F	K5.3 ■ 15 F	N1.1 ■ 35 K	N1.2 ■ 26 K	N1.3 ■ 18 J	N2.1 ■ 48 I	N2.2 ■ 43 I
N2.3 ■ 31 I	N3.1 ■ 68 J	N3.2 ■ 40 K	N3.3 ■ 20 I	N4.1 ■ 35 M	N4.2 ■ 28 K	N4.3 ■ 17 I	S1.1 ■ 30 G	S1.2 ■ 18 F	S1.3 ■ 10 C	S2.1 ■ 12 F	S2.2 ■ 8 C	S3.1 ■ 9 F	S3.2 ■ 6 C
S4.1 ■ 7 F	S4.2 ■ 5 C												

DC ≤ 1.5mm avec pointe 118°; DC < 3.00 mm 5% cobalt.

Produit	DC	DC	DC	LCF	OAL	DCON MS
	(inch)	(mm)	(inch)	(mm)	(mm)	(mm)
A1171.0	–	1.00	0.0394	6.0	26.0	1.00
A1171.1	–	1.10	0.0433	7.0	28.0	1.10
A1171.2	–	1.20	0.0472	8.0	30.0	1.20
A1171.3	–	1.30	0.0512	8.0	30.0	1.30
A1171.4	–	1.40	0.0551	9.0	32.0	1.40
A1171.5	–	1.50	0.0591	9.0	32.0	1.50
A1171.6	–	1.60	0.0630	10.0	34.0	1.60
A1171.7	–	1.70	0.0669	10.0	34.0	1.70
A1171.8	–	1.80	0.0709	11.0	36.0	1.80
A1171.9	–	1.90	0.0748	11.0	36.0	1.90
A1172.0	–	2.00	0.0787	12.0	38.0	2.00
A1172.1	–	2.10	0.0827	12.0	38.0	2.10
A1172.2	–	2.20	0.0866	13.0	40.0	2.20
A1172.3	–	2.30	0.0906	13.0	40.0	2.30
A1172.4	–	2.40	0.0945	14.0	43.0	2.40
A1172.5	–	2.50	0.0984	14.0	43.0	2.50
A1172.6	–	2.60	0.1024	14.0	43.0	2.60
A1172.7	–	2.70	0.1063	16.0	46.0	2.70
A1172.8	–	2.80	0.1102	16.0	46.0	2.80
A1172.9	–	2.90	0.1142	16.0	46.0	2.90
A1173.0	–	3.00	0.1181	16.0	46.0	3.00
A1173.1	–	3.10	0.1220	18.0	49.0	3.10
A1171/8	1/8	3.18	0.1250	18.0	49.0	3.18

Produit	DC	DC	DC	LCF	OAL	DCON MS
	(inch)	(mm)	(inch)	(mm)	(mm)	(mm)
A1173.2	–	3.20	0.1260	18.0	49.0	3.20
A1173.3	–	3.30	0.1299	18.0	49.0	3.30
A1173.4	–	3.40	0.1339	20.0	52.0	3.40
A1173.5	–	3.50	0.1378	20.0	52.0	3.50
A1173.6	–	3.60	0.1417	20.0	52.0	3.60
A1173.7	–	3.70	0.1457	20.0	52.0	3.70
A1173.8	–	3.80	0.1496	22.0	55.0	3.80
A1173.9	–	3.90	0.1535	22.0	55.0	3.90
A1175/32	5/32	3.97	0.1563	22.0	55.0	3.97
A1174.0	–	4.00	0.1575	22.0	55.0	4.00
A1174.1	–	4.10	0.1614	22.0	55.0	4.10
A1174.2	–	4.20	0.1654	22.0	55.0	4.20
A1174.3	–	4.30	0.1693	24.0	58.0	4.30
A1174.4	–	4.40	0.1732	24.0	58.0	4.40
A1174.5	–	4.50	0.1772	24.0	58.0	4.50
A1174.6	–	4.60	0.1811	24.0	58.0	4.60
A1174.7	–	4.70	0.1850	24.0	58.0	4.70
A1173/16	3/16	4.76	0.1875	26.0	62.0	4.76
A1174.8	–	4.80	0.1890	26.0	62.0	4.80
A1174.9	–	4.90	0.1929	26.0	62.0	4.90
A1175.0	–	5.00	0.1969	26.0	62.0	5.00
A1175.1	–	5.10	0.2008	26.0	62.0	5.10
A1175.2	–	5.20	0.2047	26.0	62.0	5.20



Produit	DC	DC	DC	LCF	OAL	DCON MS
	(inch)	(mm)	(inch)	(mm)	(mm)	(mm)
A1175.3	–	5.30	0.2087	26.0	62.0	5.30
A1175.4	–	5.40	0.2126	28.0	66.0	5.40
A1175.5	–	5.50	0.2165	28.0	66.0	5.50
A1175.6	–	5.60	0.2205	28.0	66.0	5.60
A1175.7	–	5.70	0.2244	28.0	66.0	5.70
A1175.8	–	5.80	0.2283	28.0	66.0	5.80
A1175.9	–	5.90	0.2323	28.0	66.0	5.90
A1176.0	–	6.00	0.2362	28.0	66.0	6.00
A1176.1	–	6.10	0.2402	31.0	70.0	6.10
A1176.2	–	6.20	0.2441	31.0	70.0	6.20
A1176.3	–	6.30	0.2480	31.0	70.0	6.30
A1171/4	1/4	6.35	0.2500	31.0	70.0	6.35
A1176.4	–	6.40	0.2520	31.0	70.0	6.40
A1176.5	–	6.50	0.2559	31.0	70.0	6.50
A1176.6	–	6.60	0.2598	31.0	70.0	6.60
A1176.7	–	6.70	0.2638	31.0	70.0	6.70
A1176.8	–	6.80	0.2677	34.0	74.0	6.80
A1176.9	–	6.90	0.2717	34.0	74.0	6.90
A1177.0	–	7.00	0.2756	34.0	74.0	7.00
A1177.1	–	7.10	0.2795	34.0	74.0	7.10
A1177.2	–	7.20	0.2835	34.0	74.0	7.20
A1177.3	–	7.30	0.2874	34.0	74.0	7.30
A1177.4	–	7.40	0.2913	34.0	74.0	7.40
A1177.5	–	7.50	0.2953	34.0	74.0	7.50
A1177.6	–	7.60	0.2992	37.0	79.0	7.60
A1177.7	–	7.70	0.3031	37.0	79.0	7.70
A1177.8	–	7.80	0.3071	37.0	79.0	7.80
A1177.9	–	7.90	0.3110	37.0	79.0	7.90
A1175/16	5/16	7.94	0.3125	37.0	79.0	7.94

Produit	DC	DC	DC	LCF	OAL	DCON MS
	(inch)	(mm)	(inch)	(mm)	(mm)	(mm)
A1178.0	–	8.00	0.3150	37.0	79.0	8.00
A1178.1	–	8.10	0.3189	37.0	79.0	8.10
A1178.2	–	8.20	0.3228	37.0	79.0	8.20
A1178.3	–	8.30	0.3268	37.0	79.0	8.30
A1178.4	–	8.40	0.3307	37.0	79.0	8.40
A1178.5	–	8.50	0.3346	37.0	79.0	8.50
A1178.6	–	8.60	0.3386	40.0	84.0	8.60
A1178.7	–	8.70	0.3425	40.0	84.0	8.70
A1178.8	–	8.80	0.3465	40.0	84.0	8.80
A1178.9	–	8.90	0.3504	40.0	84.0	8.90
A1179.0	–	9.00	0.3543	40.0	84.0	9.00
A1179.1	–	9.10	0.3583	40.0	84.0	9.10
A1179.2	–	9.20	0.3622	40.0	84.0	9.20
A1179.3	–	9.30	0.3661	40.0	84.0	9.30
A1179.4	–	9.40	0.3701	40.0	84.0	9.40
A1179.5	–	9.50	0.3740	40.0	84.0	9.50
A1173/8	3/8	9.52	0.3750	43.0	89.0	9.52
A1179.6	–	9.60	0.3780	43.0	89.0	9.60
A1179.7	–	9.70	0.3819	43.0	89.0	9.70
A1179.8	–	9.80	0.3858	43.0	89.0	9.80
A1179.9	–	9.90	0.3898	43.0	89.0	9.90
A11710.0	–	10.00	0.3937	43.0	89.0	10.00
A11710.2	–	10.20	0.4016	43.0	89.0	10.20
A11710.5	–	10.50	0.4134	43.0	89.0	10.50
A11711.0	–	11.00	0.4331	47.0	95.0	11.00
A11711.5	–	11.50	0.4528	47.0	95.0	11.50
A11712.0	–	12.00	0.4724	51.0	102.0	12.00
A1171/2	1/2	12.70	0.5000	51.0	102.0	12.70
A11713.0	–	13.00	0.5118	51.0	102.0	13.00



A520



Foret extra-court ADX en HSS, revêtement TiN

Foret haute performance capable de produire des trous de haute qualité et précis à des vitesses et des avances élevées (tolérance de trou H9). Sa pointe amincie à 130° facilite l'auto-centrage et réduit les efforts de coupe. Ce foret doit être utilisé sur des machines CNC uniquement. Le revêtement TiN prolonge la durée de vie de l'outil.



ADX

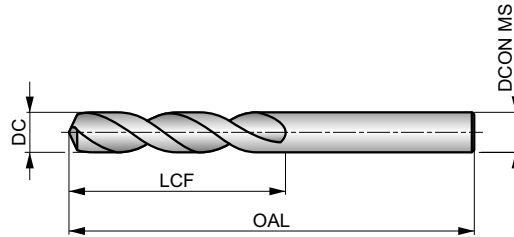

HSS	DIN 1897	2.5xD
130°	TiN	
λ 32-40°	R	DC h8

Adéquation du groupe de matériaux de la pièce, valeurs de départ pour la vitesse de coupe (m/min) et code Alpha d'avance. Les tableaux d'avances par tour se trouvent à partir de la page 175.

P1.1 ■ 53 M	P1.2 ■ 59 M	P1.3 ■ 61 M	P2.1 ■ 45 M	P2.2 ■ 40 K	P2.3 ■ 35 G	P3.1 ■ 31 I	P3.2 ■ 25 I	P3.3 ■ 21 G	P4.1 ■ 19 I	P4.2 ■ 16 G	P4.3 ■ 13 E	M1.1 ■ 41 I	M1.2 ■ 35 I
M2.1 ■ 37 I	M2.2 ■ 30 I	M3.1 ■ 19 I	M3.2 ■ 16 I	M3.3 ■ 14 I	M4.1 ■ 20 G	K1.1 ■ 48 M	K1.2 ■ 36 K	K1.3 ■ 27 K	K2.1 ■ 37 J	K2.2 ■ 30 J	K2.3 ■ 24 F	K3.1 ■ 33 J	K3.2 ■ 25 J
K3.3 ■ 20 F	K4.1 ■ 30 J	K4.2 ■ 23 J	K4.3 ■ 17 F	K4.4 ■ 14 F	K4.5 ■ 12 F	K5.1 ■ 34 J	K5.2 ■ 26 J	K5.3 ■ 20 F	N1.1 ■ 55 I	N1.2 ■ 41 I	N1.3 ■ 28 M	N2.1 ■ 57 K	N2.2 ■ 51 K
N2.3 ■ 37 K	N3.1 ■ 85 K	N3.2 ■ 50 I	N3.3 ■ 25 E	N4.1 ■ 65 G	N4.2 ■ 50 G	N4.3 ■ 35 F	S1.1 ■ 34 I	S1.2 ■ 20 G	S1.3 ■ 4 B	S2.1 ■ 15 G	S2.2 ■ 10 E	S3.1 ■ 11 G	S3.2 ■ 7 E
S4.1 ■ 9 G	S4.2 ■ 6 E												

Produit	DC	DC	DC	LCF	OAL	DCON MS
	(inch)	(mm)	(inch)	(mm)	(mm)	(mm)
A5203.0	-	3.00	0.1181	16.0	46.0	3.00
A5203.1	-	3.10	0.1220	18.0	49.0	3.10
A5201/8	1/8	3.18	0.1250	18.0	49.0	3.18
A5203.2	-	3.20	0.1260	18.0	49.0	3.20
A5203.3	-	3.30	0.1299	18.0	49.0	3.30
A5203.4	-	3.40	0.1339	20.0	52.0	3.40
A5203.5	-	3.50	0.1378	20.0	52.0	3.50
A5209/64	9/64	3.57	0.1406	20.0	52.0	3.57
A5203.6	-	3.60	0.1417	20.0	52.0	3.60
A5203.7	-	3.70	0.1457	20.0	52.0	3.70
A5203.8	-	3.80	0.1496	22.0	55.0	3.80
A5203.9	-	3.90	0.1535	22.0	55.0	3.90
A5205/32	5/32	3.97	0.1563	22.0	55.0	3.97
A5204.0	-	4.00	0.1575	22.0	55.0	4.00
A5204.1	-	4.10	0.1614	22.0	55.0	4.10
A5204.2	-	4.20	0.1654	22.0	55.0	4.20
A5204.3	-	4.30	0.1693	24.0	58.0	4.30
A52011/64	11/64	4.37	0.1719	24.0	58.0	4.37
A5204.4	-	4.40	0.1732	24.0	58.0	4.40
A5204.5	-	4.50	0.1772	24.0	58.0	4.50
A5204.6	-	4.60	0.1811	24.0	58.0	4.60
A5204.7	-	4.70	0.1850	24.0	58.0	4.70
A5203/16	3/16	4.76	0.1875	26.0	62.0	4.76
A5204.8	-	4.80	0.1890	26.0	62.0	4.80

Produit	DC	DC	DC	LCF	OAL	DCON MS
	(inch)	(mm)	(inch)	(mm)	(mm)	(mm)
A5204.9	-	4.90	0.1929	26.0	62.0	4.90
A5205.0	-	5.00	0.1969	26.0	62.0	5.00
A5205.1	-	5.10	0.2008	26.0	62.0	5.10
A52013/64	13/64	5.16	0.2031	26.0	62.0	5.16
A5205.2	-	5.20	0.2047	26.0	62.0	5.20
A5205.3	-	5.30	0.2087	26.0	62.0	5.30
A5205.4	-	5.40	0.2126	28.0	66.0	5.40
A5205.5	-	5.50	0.2165	28.0	66.0	5.50
A5207/32	7/32	5.56	0.2188	28.0	66.0	5.56
A5205.6	-	5.60	0.2205	28.0	66.0	5.60
A5205.7	-	5.70	0.2244	28.0	66.0	5.70
A5205.8	-	5.80	0.2283	28.0	66.0	5.80
A5205.9	-	5.90	0.2323	28.0	66.0	5.90
A52015/64	15/64	5.95	0.2344	28.0	66.0	5.95
A5206.0	-	6.00	0.2362	28.0	66.0	6.00
A5206.1	-	6.10	0.2402	31.0	70.0	6.10
A5206.2	-	6.20	0.2441	31.0	70.0	6.20
A5206.3	-	6.30	0.2480	31.0	70.0	6.30
A5201/4	1/4	6.35	0.2500	31.0	70.0	6.35
A5206.4	-	6.40	0.2520	31.0	70.0	6.40
A5206.5	-	6.50	0.2559	31.0	70.0	6.50
A5206.6	-	6.60	0.2598	31.0	70.0	6.60
A5206.7	-	6.70	0.2638	31.0	70.0	6.70
A52017/64	17/64	6.75	0.2656	34.0	74.0	6.75



Produit	DC	DC	DC	LCF	OAL	D CON MS
	(inch)	(mm)	(inch)	(mm)	(mm)	(mm)
A5206.8	–	6.80	0.2677	34.0	74.0	6.80
A5206.9	–	6.90	0.2717	34.0	74.0	6.90
A5207.0	–	7.00	0.2756	34.0	74.0	7.00
A5207.1	–	7.10	0.2795	34.0	74.0	7.10
A5209/32	9/32	7.14	0.2813	34.0	74.0	7.14
A5207.2	–	7.20	0.2835	34.0	74.0	7.20
A5207.3	–	7.30	0.2874	34.0	74.0	7.30
A5207.4	–	7.40	0.2913	34.0	74.0	7.40
A5207.5	–	7.50	0.2953	34.0	74.0	7.50
A52019/64	19/64	7.54	0.2969	37.0	79.0	7.54
A5207.6	–	7.60	0.2992	37.0	79.0	7.60
A5207.7	–	7.70	0.3031	37.0	79.0	7.70
A5207.8	–	7.80	0.3071	37.0	79.0	7.80
A5207.9	–	7.90	0.3110	37.0	79.0	7.90
A5205/16	5/16	7.94	0.3125	37.0	79.0	7.94
A5208.0	–	8.00	0.3150	37.0	79.0	8.00
A5208.1	–	8.10	0.3189	37.0	79.0	8.10
A5208.2	–	8.20	0.3228	37.0	79.0	8.20
A5208.3	–	8.30	0.3268	37.0	79.0	8.30
A52021/64	21/64	8.33	0.3281	37.0	79.0	8.33
A5208.4	–	8.40	0.3307	37.0	79.0	8.40
A5208.5	–	8.50	0.3346	37.0	79.0	8.50
A5208.6	–	8.60	0.3386	40.0	84.0	8.60
A5208.7	–	8.70	0.3425	40.0	84.0	8.70
A52011/32	11/32	8.73	0.3438	40.0	84.0	8.73
A5208.8	–	8.80	0.3465	40.0	84.0	8.80
A5208.9	–	8.90	0.3504	40.0	84.0	8.90
A5209.0	–	9.00	0.3543	40.0	84.0	9.00
A5209.1	–	9.10	0.3583	40.0	84.0	9.10
A52023/64	23/64	9.13	0.3594	40.0	84.0	9.13
A5209.2	–	9.20	0.3622	40.0	84.0	9.20
A5209.3	–	9.30	0.3661	40.0	84.0	9.30
A5209.4	–	9.40	0.3701	40.0	84.0	9.40
A5209.5	–	9.50	0.3740	40.0	84.0	9.50
A5203/8	3/8	9.52	0.3750	43.0	89.0	9.52
A5209.6	–	9.60	0.3780	43.0	89.0	9.60
A5209.7	–	9.70	0.3819	43.0	89.0	9.70
A5209.8	–	9.80	0.3858	43.0	89.0	9.80
A5209.9	–	9.90	0.3898	43.0	89.0	9.90

Produit	DC	DC	DC	LCF	OAL	D CON MS
	(inch)	(mm)	(inch)	(mm)	(mm)	(mm)
A52025/64	25/64	9.92	0.3906	43.0	89.0	9.92
A52010.0	–	10.00	0.3937	43.0	89.0	10.00
A52010.1	–	10.10	0.3976	43.0	89.0	10.10
A52010.2	–	10.20	0.4016	43.0	89.0	10.20
A52010.3	–	10.30	0.4055	43.0	89.0	10.30
A52013/32	13/32	10.32	0.4063	43.0	89.0	10.32
A52010.4	–	10.40	0.4094	43.0	89.0	10.40
A52010.5	–	10.50	0.4134	43.0	89.0	10.50
A52010.6	–	10.60	0.4173	43.0	89.0	10.60
A52010.7	–	10.70	0.4213	47.0	95.0	10.70
A52027/64	27/64	10.72	0.4219	47.0	95.0	10.72
A52010.8	–	10.80	0.4252	47.0	95.0	10.80
A52010.9	–	10.90	0.4291	47.0	95.0	10.90
A52011.0	–	11.00	0.4331	47.0	95.0	11.00
A52011.1	–	11.10	0.4370	47.0	95.0	11.10
A5207/16	7/16	11.11	0.4375	47.0	95.0	11.11
A52011.2	–	11.20	0.4409	47.0	95.0	11.20
A52011.3	–	11.30	0.4449	47.0	95.0	11.30
A52011.4	–	11.40	0.4488	47.0	95.0	11.40
A52011.5	–	11.50	0.4528	47.0	95.0	11.50
A52029/64	29/64	11.51	0.4531	47.0	95.0	11.51
A52011.6	–	11.60	0.4567	47.0	95.0	11.60
A52011.7	–	11.70	0.4606	47.0	95.0	11.70
A52011.8	–	11.80	0.4646	47.0	95.0	11.80
A52011.9	–	11.90	0.4685	51.0	102.0	11.90
A52015/32	15/32	11.91	0.4688	51.0	102.0	11.91
A52012.0	–	12.00	0.4724	51.0	102.0	12.00
A52012.1	–	12.10	0.4764	51.0	102.0	12.10
A52012.2	–	12.20	0.4803	51.0	102.0	12.20
A52012.3	–	12.30	0.4843	51.0	102.0	12.30
A52031/64	31/64	12.30	0.4844	51.0	102.0	12.30
A52012.4	–	12.40	0.4882	51.0	102.0	12.40
A52012.5	–	12.50	0.4921	51.0	102.0	12.50
A52012.6	–	12.60	0.4961	51.0	102.0	12.60
A52012.7	–	12.70	0.5000	51.0	102.0	12.70
A5201/2	1/2	12.70	0.5000	51.0	102.0	12.70
A52012.8	–	12.80	0.5039	51.0	102.0	12.80
A52012.9	–	12.90	0.5079	51.0	102.0	12.90
A52013.0	–	13.00	0.5118	51.0	102.0	13.00



A124



Foret extra-court en HSS, finition avec traitement vapeur, avec pointe en carbure brasée

Foret à pointe en carbure brasée offrant les performances élevées d'un foret en carbure monobloc grâce à son corps en HSS moins cassant. Sa pointe à 118° à 4 facettes facilite l'auto-centrage ce qui en fait un choix économique. Il peut être utilisé sur des machines conventionnelles et CNC. La finition avec traitement vapeur retient le fluide de coupe.

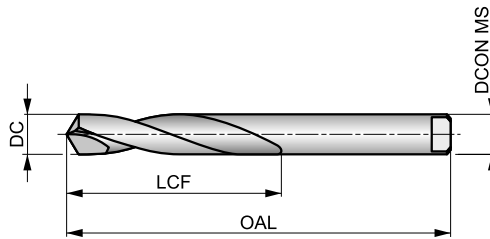

HSS HM	DIN 8037	2.5×D
118°	Bright ST	
λ 10-20°	R	

Adéquation du groupe de matériaux de la pièce, valeurs de départ pour la vitesse de coupe (m/min) et code Alpha d'avance. Les tableaux d'avances par tour se trouvent à partir de la page 175.

P2.3 ■ 40 C	P3.3 ■ 40 C	P4.2 ■ 30 C	P4.3 ■ 24 A	M3.1 ■ 41 C	M3.2 ■ 35 C	M3.3 ■ 32 C	M4.1 ■ 35 C	K1.1 ■ 55 C	K1.2 ■ 41 C	K1.3 ■ 31 C	K2.1 ■ 49 C	K2.2 ■ 40 C	K2.3 ■ 32 A
K3.1 ■ 44 C	K3.2 ■ 33 C	K3.3 ■ 27 A	K4.1 ■ 40 C	K4.2 ■ 30 C	K4.3 ■ 22 A	K4.4 ■ 19 A	K4.5 ■ 16 A	K5.1 ■ 46 C	K5.2 ■ 34 C	K5.3 ■ 27 A	N3.1 ■ 119 E	N3.2 ■ 170 G	N4.2 ■ 60 E
S1.1 ■ 40 A	S1.2 ■ 35 A	S1.3 ■ 25 A	S2.1 ■ 33 A	S2.2 ■ 28 A	S3.1 ■ 25 A	S3.2 ■ 20 A	S4.1 ■ 20 A	S4.2 ■ 16 A					

Tenon selon DIN 1809.

Produit	DC	DC	LCF	OAL	DCON MS
	(mm)	(inch)			
A1243.0	3.00	0.1181	20.0	50.0	3.00
A1243.2	3.20	0.1260	25.0	56.0	3.20
A1243.5	3.50	0.1378	25.0	56.0	3.50
A1244.0	4.00	0.1575	25.0	56.0	4.00
A1244.2	4.20	0.1654	28.0	63.0	4.20
A1244.5	4.50	0.1772	28.0	63.0	4.50
A1244.8	4.80	0.1890	28.0	63.0	4.80
A1245.0	5.00	0.1969	28.0	63.0	5.00
A1245.2	5.20	0.2047	32.0	71.0	5.20
A1245.5	5.50	0.2165	32.0	71.0	5.50
A1245.8	5.80	0.2283	32.0	71.0	5.80
A1246.0	6.00	0.2362	32.0	71.0	6.00
A1246.5	6.50	0.2559	32.0	71.0	6.50
A1246.8	6.80	0.2677	40.0	80.0	6.80
A1247.0	7.00	0.2756	40.0	80.0	7.00

Produit	DC	DC	LCF	OAL	DCON MS
	(mm)	(inch)			
A1247.5	7.50	0.2953	40.0	80.0	7.50
A1248.0	8.00	0.3150	40.0	80.0	8.00
A1248.5	8.50	0.3346	50.0	90.0	8.50
A1249.0	9.00	0.3543	50.0	90.0	9.00
A1249.5	9.50	0.3740	50.0	90.0	9.50
A12410.0	10.00	0.3937	56.0	100.0	10.00
A12410.5	10.50	0.4134	56.0	100.0	10.50
A12411.0	11.00	0.4331	56.0	100.0	11.00
A12411.5	11.50	0.4528	63.0	112.0	11.50
A12412.0	12.00	0.4724	63.0	112.0	12.00
A12413.0	13.00	0.5118	63.0	112.0	13.00
A12414.0	14.00	0.5512	71.0	125.0	14.00
A12415.0	15.00	0.5906	71.0	125.0	15.00
A12416.0	16.00	0.6299	80.0	140.0	16.00



A720



Micro-foret en HSS-E (5% cobalt), finition brillante

Micro foret de très petits diamètres allant de 0,15 mm à 1,40 mm. Pour faciliter la tenue de l'outil, tous les forets ont un diamètre de queue de 1,00 mm ou 1,50 mm. Les forets ont tous une pointe à 118° à 4 facettes qui facilite l'auto-centrage et réduit les forces de coupe.

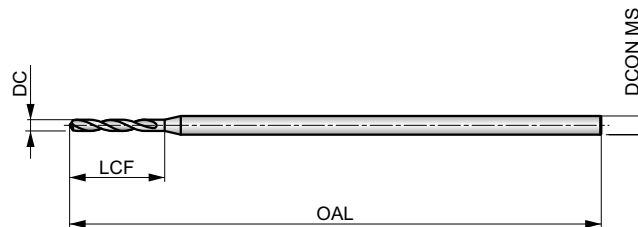

HSS-E	DIN 1899	2.5×D
118°	Bright	
20-35°	R	

Adéquation du groupe de matériaux de la pièce, valeurs de départ pour la vitesse de coupe (m/min) et code Alpha d'avance. Les tableaux d'avances par tour se trouvent à partir de la page 175.

P1.1 ■ 36 A	P1.2 ■ 40 A	P1.3 ■ 41 A	P2.1 ■ 31 A	P2.2 ■ 27 A	P2.3 ■ 24 A	P3.1 ■ 25 A	P3.2 ■ 20 A	P3.3 ■ 17 A	P4.1 ■ 15 A	P4.2 ■ 13 A	P4.3 ■ 10 A	M1.1 ■ 30 A	M1.2 ■ 26 A
M2.1 ■ 27 A	M2.2 ■ 22 A	M3.1 ■ 12 A	M3.2 ■ 10 A	M3.3 ■ 9 A	M4.1 ■ 15 A	K1.1 ■ 30 A	K1.2 ■ 22 A	K1.3 ■ 17 A	K2.1 ■ 25 A	K2.2 ■ 20 A	K2.3 ■ 16 A	K3.1 ■ 22 A	K3.2 ■ 17 A
K3.3 ■ 13 A	K4.1 ■ 20 A	K4.2 ■ 15 A	K4.3 ■ 11 A	K4.4 ■ 10 A	K4.5 ■ 8 A	K5.1 ■ 23 A	K5.2 ■ 17 A	K5.3 ■ 13 A	N1.1 ■ 35 A	N1.2 ■ 26 A	N1.3 ■ 18 A	N2.1 ■ 42 A	N2.2 ■ 37 A
N2.3 ■ 27 A	N3.1 ■ 68 A	N3.2 ■ 40 A	N3.3 ■ 20 A	N4.1 ■ 48 A	N4.2 ■ 25 A	S1.1 ■ 23 A	S1.2 ■ 17 A	S1.3 ■ 8 A	S2.1 ■ 9 A	S2.2 ■ 6 A	S3.1 ■ 7 A	S3.2 ■ 4 A	S4.1 ■ 5 A
S4.2 ■ 3 A													

Produit	DC	DC	LCF	OAL	DCON MS	Produit	DC	DC	LCF	OAL	DCON MS
	(mm)	(inch)					(mm)	(mm)			
A720.15	0.15	0.0059	1.0	25.0	1.00	A720.55	0.55	0.0217	4.5	25.0	1.00
A720.16	0.16	0.0063	1.4	25.0	1.00	A720.6	0.60	0.0236	4.5	25.0	1.00
A720.17	0.17	0.0067	1.4	25.0	1.00	A720.62	0.62	0.0244	5.0	25.0	1.00
A720.18	0.18	0.0070	1.4	25.0	1.00	A720.65	0.65	0.0256	5.0	25.0	1.00
A720.2	0.20	0.0079	1.8	25.0	1.00	A720.7	0.70	0.0276	5.6	25.0	1.00
A720.22	0.22	0.0087	1.8	25.0	1.00	A720.75	0.75	0.0295	5.6	25.0	1.00
A720.25	0.25	0.0098	2.2	25.0	1.00	A720.8	0.80	0.0315	6.3	25.0	1.50
A720.27	0.27	0.0106	2.2	25.0	1.00	A720.85	0.85	0.0335	6.3	25.0	1.50
A720.28	0.28	0.0110	2.2	25.0	1.00	A720.9	0.90	0.0354	7.1	25.0	1.50
A720.3	0.30	0.0118	2.2	25.0	1.00	A720.95	0.95	0.0374	7.1	25.0	1.50
A720.35	0.35	0.0138	2.8	25.0	1.00	A7201.0	1.00	0.0394	8.0	25.0	1.50
A720.38	0.38	0.0150	2.8	25.0	1.00	A7201.05	1.05	0.0413	8.0	25.0	1.50
A720.39	0.39	0.0154	3.6	25.0	1.00	A7201.1	1.10	0.0433	9.0	25.0	1.50
A720.4	0.40	0.0157	3.6	25.0	1.00	A7201.2	1.20	0.0472	10.0	25.0	1.50
A720.45	0.45	0.0177	3.6	25.0	1.00	A7201.3	1.30	0.0512	10.0	25.0	1.50
A720.5	0.50	0.0197	4.0	25.0	1.00	A7201.4	1.40	0.0551	11.2	25.0	1.50



A920



Foret extra-court PFX en HSS-E (5% cobalt), finition brillante

Foret haute performance capable de produire des trous de haute qualité et précis à des vitesses et des avances élevées (tolérance de trou H10). Sa pointe auto-centrante à 130° et la conception spéciale de sa goujure parabolique permettent de percer des trous profonds en une seule passe. Convient à de nombreux matériaux.

PFX

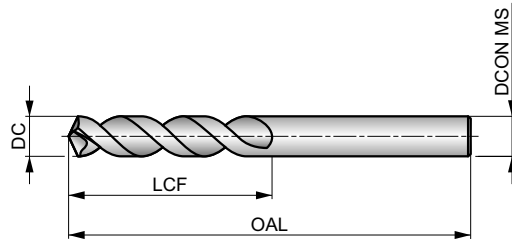

HSS-E	DIN ANSI	3xD
130°	Bright	
λ > 35°	R	DC h8

Adéquation du groupe de matériaux de la pièce, valeurs de départ pour la vitesse de coupe (m/min) et code Alpha d'avance. Les tableaux d'avances par tour se trouvent à partir de la page 175.

P1.1 ■ 42 J	P1.2 ■ 47 J	P1.3 ■ 49 J	P2.1 ■ 36 J	P2.2 ■ 32 I	P2.3 ■ 28 E	P3.1 ■ 34 I	P3.2 ■ 27 I	P3.3 ■ 23 E	P4.1 ■ 20 I	P4.2 ■ 17 E	P4.3 ■ 14 E	M1.1 ■ 21 F	M1.2 ■ 17 F
M2.1 ■ 18 F	M2.2 ■ 15 F	M3.1 ■ 8 F	M3.2 ■ 7 F	M3.3 ■ 6 F	M4.1 ■ 9 D	K1.1 ■ 34 L	K1.2 ■ 25 L	K1.3 ■ 19 L	K2.1 ■ 32 L	K2.2 ■ 26 L	K2.3 ■ 21 J	K3.1 ■ 28 L	K3.2 ■ 22 L
K3.3 ■ 17 J	K4.1 ■ 26 L	K4.2 ■ 20 L	K4.3 ■ 14 J	K4.4 ■ 12 J	K4.5 ■ 10 J	K5.1 ■ 30 L	K5.2 ■ 22 L	K5.3 ■ 17 J	N1.1 ■ 75 L	N1.2 ■ 56 L	N1.3 ■ 38 N	N2.1 ■ 62 N	N2.2 ■ 55 N
N2.3 ■ 40 N	N3.1 ■ 112 J	N3.2 ■ 66 J	N3.3 ■ 33 H	N4.1 ■ 55 J	N4.2 ■ 40 H	S1.1 ■ 30 G	S1.2 ■ 18 G	S1.3 ■ 10 C	S2.1 ■ 12 G	S2.2 ■ 8 E	S3.1 ■ 9 G	S3.2 ■ 6 E	S4.1 ■ 7 G
S4.2 ■ 5 E													

Produit	DC	DC	DC	LCF	OAL	DCON MS
	(inch)	(mm)	(inch)	(mm)	(mm)	(mm)
A9201.0	—	1.00	0.0394	6.0	26.0	1.00
A9201.1	—	1.10	0.0433	7.0	28.0	1.10
A9203/64	3/64	1.19	0.0469	13.0	35.0	1.19
A9201.2	—	1.20	0.0472	8.0	30.0	1.20
A9201.25	—	1.25	0.0492	8.0	30.0	1.25
A9201.3	—	1.30	0.0512	8.0	30.0	1.30
A9201.35	—	1.35	0.0531	9.0	32.0	1.35
A9201.4	—	1.40	0.0551	9.0	32.0	1.40
A9201.5	—	1.50	0.0591	9.0	32.0	1.50
A9201.55	—	1.55	0.0610	10.0	34.0	1.55
A9201/16	1/16	1.59	0.0625	16.0	41.0	1.59
A9201.6	—	1.60	0.0630	10.0	34.0	1.60
A9201.7	—	1.70	0.0669	10.0	34.0	1.70
A9201.75	—	1.75	0.0689	11.0	36.0	1.75
A9201.8	—	1.80	0.0709	11.0	36.0	1.80
A9201.9	—	1.90	0.0748	11.0	36.0	1.90
A9205/64	5/64	1.98	0.0781	17.0	43.0	1.98
A9202.0	—	2.00	0.0787	12.0	38.0	2.00
A9202.1	—	2.10	0.0827	12.0	38.0	2.10
A9202.15	—	2.15	0.0846	13.0	40.0	2.15
A9202.2	—	2.20	0.0866	13.0	40.0	2.20
A9202.3	—	2.30	0.0906	13.0	40.0	2.30
A9202.35	—	2.35	0.0925	14.0	43.0	2.35
A9203/32	3/32	2.38	0.0938	19.0	41.0	2.38

Produit	DC	DC	DC	LCF	OAL	DCON MS
	(inch)	(mm)	(inch)	(mm)	(mm)	(mm)
A9202.4	—	2.40	0.0945	14.0	43.0	2.40
A9202.5	—	2.50	0.0984	14.0	43.0	2.50
A9202.6	—	2.60	0.1024	14.0	43.0	2.60
A9202.7	—	2.70	0.1063	16.0	46.0	2.70
A9207/64	7/64	2.78	0.1094	21.0	46.0	2.78
A9202.8	—	2.80	0.1102	16.0	46.0	2.80
A9202.9	—	2.90	0.1142	16.0	46.0	2.90
A9203.0	—	3.00	0.1181	16.0	46.0	3.00
A9203.1	—	3.10	0.1220	18.0	49.0	3.10
A9201/8	1/8	3.18	0.1250	22.0	48.0	3.18
A9203.2	—	3.20	0.1260	18.0	49.0	3.20
A9203.3	—	3.30	0.1299	18.0	49.0	3.30
A9203.4	—	3.40	0.1339	20.0	52.0	3.40
A9203.5	—	3.50	0.1378	20.0	52.0	3.50
A9209/64	9/64	3.57	0.1406	24.0	49.0	3.57
A9203.6	—	3.60	0.1417	20.0	52.0	3.60
A9203.7	—	3.70	0.1457	20.0	52.0	3.70
A9203.8	—	3.80	0.1496	22.0	55.0	3.80
A9203.9	—	3.90	0.1535	22.0	55.0	3.90
A9205/32	5/32	3.97	0.1563	25.0	52.0	3.97
A9204.0	—	4.00	0.1575	22.0	55.0	4.00
A9204.1	—	4.10	0.1614	22.0	55.0	4.10
A9204.2	—	4.20	0.1654	22.0	55.0	4.20
A9204.3	—	4.30	0.1693	24.0	58.0	4.30



Produit	DC	DC	DC	LCF	OAL	D CON MS
	(inch)	(mm)	(inch)	(mm)	(mm)	(mm)
A92011/64	11/64	4.37	0.1719	27.0	54.0	4.37
A9204.4	–	4.40	0.1732	24.0	58.0	4.40
A9204.5	–	4.50	0.1772	24.0	58.0	4.50
A9204.6	–	4.60	0.1811	24.0	58.0	4.60
A9204.7	–	4.70	0.1850	24.0	58.0	4.70
A9203/16	3/16	4.76	0.1875	29.0	56.0	4.76
A9204.8	–	4.80	0.1890	26.0	62.0	4.80
A9204.9	–	4.90	0.1929	26.0	62.0	4.90
A9205.0	–	5.00	0.1969	26.0	62.0	5.00
A9205.1	–	5.10	0.2008	26.0	62.0	5.10
A92013/64	13/64	5.16	0.2031	30.0	57.0	5.16
A9205.2	–	5.20	0.2047	26.0	62.0	5.20
A9205.3	–	5.30	0.2087	26.0	62.0	5.30
A9205.4	–	5.40	0.2126	28.0	66.0	5.40
A9205.5	–	5.50	0.2165	28.0	66.0	5.50
A9207/32	7/32	5.56	0.2188	32.0	60.0	5.56
A9205.6	–	5.60	0.2205	28.0	66.0	5.60
A9205.7	–	5.70	0.2244	28.0	66.0	5.70
A9205.8	–	5.80	0.2283	28.0	66.0	5.80
A9205.9	–	5.90	0.2323	28.0	66.0	5.90
A92015/64	15/64	5.95	0.2344	33.0	62.0	5.95
A9206.0	–	6.00	0.2362	28.0	66.0	6.00
A9206.1	–	6.10	0.2402	31.0	70.0	6.10
A9206.2	–	6.20	0.2441	31.0	70.0	6.20
A9206.3	–	6.30	0.2480	31.0	70.0	6.30
A9201/4	1/4	6.35	0.2500	35.0	64.0	6.35
A9206.4	–	6.40	0.2520	31.0	70.0	6.40
A9206.5	–	6.50	0.2559	31.0	70.0	6.50
A9206.6	–	6.60	0.2598	31.0	70.0	6.60
A9206.7	–	6.70	0.2638	31.0	70.0	6.70
A92017/64	17/64	6.75	0.2656	37.0	67.0	6.75
A9206.8	–	6.80	0.2677	34.0	74.0	6.80
A9206.9	–	6.90	0.2717	34.0	74.0	6.90
A9207.0	–	7.00	0.2756	34.0	74.0	7.00
A9207.1	–	7.10	0.2795	34.0	74.0	7.10
A9209/32	9/32	7.14	0.2813	38.0	68.0	7.14
A9207.2	–	7.20	0.2835	34.0	74.0	7.20
A9207.3	–	7.30	0.2874	34.0	74.0	7.30
A9207.4	–	7.40	0.2913	34.0	74.0	7.40
A9207.5	–	7.50	0.2953	34.0	74.0	7.50
A92019/64	19/64	7.54	0.2969	40.0	70.0	7.54
A9207.6	–	7.60	0.2992	37.0	79.0	7.60
A9207.7	–	7.70	0.3031	37.0	79.0	7.70
A9207.8	–	7.80	0.3071	37.0	79.0	7.80
A9207.9	–	7.90	0.3110	37.0	79.0	7.90
A9205/16	5/16	7.94	0.3125	41.0	71.0	7.94
A9208.0	–	8.00	0.3150	37.0	79.0	8.00
A9208.1	–	8.10	0.3189	37.0	79.0	8.10
A9208.2	–	8.20	0.3228	37.0	79.0	8.20
A9208.3	–	8.30	0.3268	37.0	79.0	8.30
A92021/64	21/64	8.33	0.3281	43.0	75.0	8.33
A9208.4	–	8.40	0.3307	37.0	79.0	8.40
A9208.5	–	8.50	0.3346	37.0	79.0	8.50
A9208.6	–	8.60	0.3386	40.0	84.0	8.60
A9208.7	–	8.70	0.3425	40.0	84.0	8.70
A92011/32	11/32	8.73	0.3438	43.0	76.0	8.73
A9208.8	–	8.80	0.3465	40.0	84.0	8.80
A9208.9	–	8.90	0.3504	40.0	84.0	8.90
A9209.0	–	9.00	0.3543	40.0	84.0	9.00
A9209.1	–	9.10	0.3583	40.0	84.0	9.10
A92023/64	23/64	9.13	0.3594	44.0	78.0	9.13
A9209.2	–	9.20	0.3622	40.0	84.0	9.20

Produit	DC	DC	DC	LCF	OAL	D CON MS
	(inch)	(mm)	(inch)	(mm)	(mm)	(mm)
A9209.3	–	9.30	0.3661	40.0	84.0	9.30
A9209.4	–	9.40	0.3701	40.0	84.0	9.40
A9209.5	–	9.50	0.3740	40.0	84.0	9.50
A9203/8	3/8	9.52	0.3750	46.0	79.0	9.52
A9209.6	–	9.60	0.3780	43.0	89.0	9.60
A9209.7	–	9.70	0.3819	43.0	89.0	9.70
A9209.8	–	9.80	0.3858	43.0	89.0	9.80
A9209.9	–	9.90	0.3898	43.0	89.0	9.90
A92025/64	25/64	9.92	0.3906	48.0	83.0	9.92
A92010.0	–	10.00	0.3937	43.0	89.0	10.00
A92010.2	–	10.20	0.4016	43.0	89.0	10.20
A92010.3	–	10.30	0.4055	43.0	89.0	10.30
A92013/32	13/32	10.32	0.4063	49.0	84.0	10.32
A92010.5	–	10.50	0.4134	43.0	89.0	10.50
A92027/64	27/64	10.72	0.4219	51.0	86.0	10.72
A92010.8	–	10.80	0.4252	47.0	95.0	10.80
A92011.0	–	11.00	0.4331	47.0	95.0	11.00
A9207/16	7/16	11.11	0.4375	52.0	87.0	11.11
A92011.5	–	11.50	0.4528	47.0	95.0	11.50
A92029/64	29/64	11.51	0.4531	54.0	90.0	11.51
A92011.8	–	11.80	0.4646	47.0	95.0	11.80
A92015/32	15/32	11.91	0.4688	54.0	92.0	11.91
A92012.0	–	12.00	0.4724	51.0	102.0	12.00
A92012.2	–	12.20	0.4803	51.0	102.0	12.20
A92031/64	31/64	12.30	0.4844	56.0	94.0	12.30
A92012.5	–	12.50	0.4921	51.0	102.0	12.50
A9201/2	1/2	12.70	0.5000	57.0	95.0	12.70
A92013.0	–	13.00	0.5118	51.0	102.0	13.00
A92033/64	33/64	13.10	0.5156	60.0	98.0	13.10
A92013.5	–	13.50	0.5315	54.0	107.0	13.50
A92035/64	35/64	13.89	0.5469	64.0	102.0	13.89
A92014.0	–	14.00	0.5512	54.0	107.0	14.00
A9209/16	9/16	14.29	0.5625	64.0	102.0	14.29
A92014.5	–	14.50	0.5709	56.0	111.0	14.50
A92037/64	37/64	14.68	0.5781	67.0	105.0	14.68
A92014.75	–	14.75	0.5807	56.0	111.0	14.75
A92015.0	–	15.00	0.5906	56.0	111.0	15.00
A92019/32	19/32	15.08	0.5938	67.0	105.0	15.08
A92039/64	39/64	15.48	0.6094	70.0	108.0	15.48
A92015.5	–	15.50	0.6102	58.0	115.0	15.50
A9205/8	5/8	15.88	0.6250	70.0	108.0	15.88
A92016.0	–	16.00	0.6299	58.0	115.0	16.00
A92041/64	41/64	16.27	0.6406	73.0	114.0	16.27
A92016.5	–	16.50	0.6496	60.0	119.0	16.50
A92021/32	21/32	16.67	0.6563	73.0	114.0	16.67
A92016.75	–	16.75	0.6594	60.0	119.0	16.75
A92017.0	–	17.00	0.6693	60.0	119.0	17.00
A92043/64	43/64	17.07	0.6719	73.0	117.0	17.07
A92011/16	11/16	17.46	0.6875	73.0	117.0	17.46
A92017.5	–	17.50	0.6890	62.0	123.0	17.50
A92045/64	45/64	17.86	0.7031	76.0	121.0	17.86
A92018.0	–	18.00	0.7087	62.0	123.0	18.00
A92023/32	23/32	18.26	0.7188	76.0	121.0	18.26
A92018.5	–	18.50	0.7283	64.0	127.0	18.50
A92047/64	47/64	18.65	0.7344	79.0	127.0	18.65
A92019.0	–	19.00	0.7480	64.0	127.0	19.00
A9203/4	3/4	19.05	0.7500	79.0	127.0	19.05
A92049/64	49/64	19.45	0.7656	83.0	130.0	19.45
A92019.5	–	19.50	0.7677	66.0	131.0	19.50
A92025/32	25/32	19.84	0.7813	83.0	130.0	19.84
A92020.0	–	20.00	0.7874	66.0	131.0	20.00



A921



Foret extra-court PFX en HSS-E (5% cobalt), revêtement Alcrona

Foret haute performance capable de produire des trous de haute qualité et précis à des vitesses et des avances élevées (tolérance de trou H10). Il possède une pointe auto-centrante à 130° et une conception spéciale de goujure parabolique. Convient à de nombreux matériaux. Le revêtement Alcrona-TOP améliore les performances et prolonge la durée de vie de l'outil.



PFX

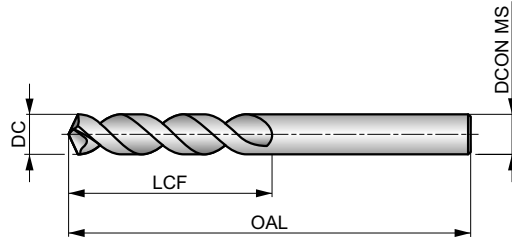

HSS-E	DIN ANSI	3xD
130°	Alcrona Top	
λ > 35°	R	DC h8

Adéquation du groupe de matériaux de la pièce, valeurs de départ pour la vitesse de coupe (m/min) et code Alpha d'avance. Les tableaux d'avances par tour se trouvent à partir de la page 175.

P1.1 ■ 70 M	P1.2 ■ 79 M	P1.3 ■ 81 M	P2.1 ■ 60 M	P2.2 ■ 53 J	P2.3 ■ 47 G	P3.1 ■ 56 J	P3.2 ■ 45 J	P3.3 ■ 38 G	P4.1 ■ 33 J	P4.2 ■ 28 G	P4.3 ■ 23 G	M1.1 ■ 23 F	M1.2 ■ 20 F
M2.1 ■ 21 F	M2.2 ■ 17 F	M3.1 ■ 10 F	M3.2 ■ 9 F	M3.3 ■ 8 F	M4.1 ■ 11 D	K1.1 ■ 53 L	K1.2 ■ 39 L	K1.3 ■ 29 L	K2.1 ■ 52 L	K2.2 ■ 42 L	K2.3 ■ 33 J	K3.1 ■ 46 L	K3.2 ■ 35 L
K3.3 ■ 28 J	K4.1 ■ 42 L	K4.2 ■ 32 L	K4.3 ■ 23 J	K4.4 ■ 20 J	K4.5 ■ 17 J	K5.1 ■ 48 L	K5.2 ■ 36 L	K5.3 ■ 28 J	S1.1 ■ 48 I	S1.2 ■ 29 I	S1.3 ■ 16 E	S2.1 ■ 19 I	S2.2 ■ 14 G
S3.1 ■ 14 I	S3.2 ■ 10 G	S4.1 ■ 11 I	S4.2 ■ 8 G										

Produit	DC	DC	DC	LCF	OAL	DCON MS
	(inch)	(mm)	(inch)	(mm)	(mm)	(mm)
A9212.5	–	2.50	0.0984	14.0	43.0	2.50
A9212.6	–	2.60	0.1024	14.0	43.0	2.60
A9212.7	–	2.70	0.1063	16.0	46.0	2.70
A9217/64	7/64	2.78	0.1094	21.0	46.0	2.78
A9212.9	–	2.90	0.1142	16.0	46.0	2.90
A9213.0	–	3.00	0.1181	16.0	46.0	3.00
A9213.1	–	3.10	0.1220	18.0	49.0	3.10
A9211/8	1/8	3.18	0.1250	22.0	48.0	3.18
A9213.2	–	3.20	0.1260	18.0	49.0	3.20
A9213.3	–	3.30	0.1299	18.0	49.0	3.30
A9213.4	–	3.40	0.1339	20.0	52.0	3.40
A9213.5	–	3.50	0.1378	20.0	52.0	3.50
A9219/64	9/64	3.57	0.1406	24.0	49.0	3.57
A9213.6	–	3.60	0.1417	20.0	52.0	3.60
A9213.7	–	3.70	0.1457	20.0	52.0	3.70
A9213.8	–	3.80	0.1496	22.0	55.0	3.80
A9213.9	–	3.90	0.1535	22.0	55.0	3.90
A9215/32	5/32	3.97	0.1563	25.0	52.0	3.97
A9214.0	–	4.00	0.1575	22.0	55.0	4.00
A9214.1	–	4.10	0.1614	22.0	55.0	4.10
A9214.2	–	4.20	0.1654	22.0	55.0	4.20
A9214.3	–	4.30	0.1693	24.0	58.0	4.30
A92111/64	11/64	4.37	0.1719	27.0	54.0	4.37
A9214.4	–	4.40	0.1732	24.0	58.0	4.40
A9214.5	–	4.50	0.1772	24.0	58.0	4.50
A9214.6	–	4.60	0.1811	24.0	58.0	4.60

Produit	DC	DC	DC	LCF	OAL	DCON MS
	(inch)	(mm)	(inch)	(mm)	(mm)	(mm)
A9214.7	–	4.70	0.1850	24.0	58.0	4.70
A9213/16	3/16	4.76	0.1875	29.0	56.0	4.76
A9214.8	–	4.80	0.1890	26.0	62.0	4.80
A9214.9	–	4.90	0.1929	26.0	62.0	4.90
A9215.0	–	5.00	0.1969	26.0	62.0	5.00
A9215.1	–	5.10	0.2008	26.0	62.0	5.10
A92113/64	13/64	5.16	0.2031	30.0	57.0	5.16
A9215.2	–	5.20	0.2047	26.0	62.0	5.20
A9215.3	–	5.30	0.2087	26.0	62.0	5.30
A9215.4	–	5.40	0.2126	28.0	66.0	5.40
A9215.5	–	5.50	0.2165	28.0	66.0	5.50
A9217/32	7/32	5.56	0.2188	32.0	60.0	5.56
A9215.6	–	5.60	0.2205	28.0	66.0	5.60
A9215.7	–	5.70	0.2244	28.0	66.0	5.70
A9215.8	–	5.80	0.2283	28.0	66.0	5.80
A9215.9	–	5.90	0.2323	28.0	66.0	5.90
A92115/64	15/64	5.95	0.2344	33.0	62.0	5.95
A9216.0	–	6.00	0.2362	28.0	66.0	6.00
A9216.1	–	6.10	0.2402	31.0	70.0	6.10
A9216.2	–	6.20	0.2441	31.0	70.0	6.20
A9216.3	–	6.30	0.2480	31.0	70.0	6.30
A9211/4	1/4	6.35	0.2500	35.0	64.0	6.35
A9216.4	–	6.40	0.2520	31.0	70.0	6.40
A9216.5	–	6.50	0.2559	31.0	70.0	6.50
A9216.6	–	6.60	0.2598	31.0	70.0	6.60
A9216.7	–	6.70	0.2638	31.0	70.0	6.70



Produit	DC	DC	DC	LCF	OAL	DCON MS
	(inch)	(mm)	(inch)	(mm)	(mm)	(mm)
A92117/64	17/64	6.75	0.2656	37.0	67.0	6.75
A9216.8	–	6.80	0.2677	34.0	74.0	6.80
A9216.9	–	6.90	0.2717	34.0	74.0	6.90
A9217.0	–	7.00	0.2756	34.0	74.0	7.00
A9217.1	–	7.10	0.2795	34.0	74.0	7.10
A9219/32	9/32	7.14	0.2813	38.0	68.0	7.14
A9217.2	–	7.20	0.2835	34.0	74.0	7.20
A9217.3	–	7.30	0.2874	34.0	74.0	7.30
A9217.4	–	7.40	0.2913	34.0	74.0	7.40
A9217.5	–	7.50	0.2953	34.0	74.0	7.50
A92119/64	19/64	7.54	0.2969	40.0	70.0	7.54
A9217.6	–	7.60	0.2992	37.0	79.0	7.60
A9217.7	–	7.70	0.3031	37.0	79.0	7.70
A9217.8	–	7.80	0.3071	37.0	79.0	7.80
A9217.9	–	7.90	0.3110	37.0	79.0	7.90
A9215/16	5/16	7.94	0.3125	41.0	71.0	7.94
A9218.0	–	8.00	0.3150	37.0	79.0	8.00
A9218.1	–	8.10	0.3189	37.0	79.0	8.10
A9218.2	–	8.20	0.3228	37.0	79.0	8.20
A9218.3	–	8.30	0.3268	37.0	79.0	8.30
A92121/64	21/64	8.33	0.3281	43.0	75.0	8.33
A9218.4	–	8.40	0.3307	37.0	79.0	8.40
A9218.5	–	8.50	0.3346	37.0	79.0	8.50
A9218.6	–	8.60	0.3386	40.0	84.0	8.60
A9218.7	–	8.70	0.3425	40.0	84.0	8.70
A92111/32	11/32	8.73	0.3438	43.0	76.0	8.73
A9218.8	–	8.80	0.3465	40.0	84.0	8.80
A9218.9	–	8.90	0.3504	40.0	84.0	8.90
A9219.0	–	9.00	0.3543	40.0	84.0	9.00
A9219.1	–	9.10	0.3583	40.0	84.0	9.10
A92123/64	23/64	9.13	0.3594	44.0	78.0	9.13
A9219.2	–	9.20	0.3622	40.0	84.0	9.20
A9219.3	–	9.30	0.3661	40.0	84.0	9.30
A9219.4	–	9.40	0.3701	40.0	84.0	9.40
A9219.5	–	9.50	0.3740	40.0	84.0	9.50
A9213/8	3/8	9.52	0.3750	46.0	79.0	9.52
A9219.6	–	9.60	0.3780	43.0	89.0	9.60

Produit	DC	DC	DC	LCF	OAL	DCON MS
	(inch)	(mm)	(inch)	(mm)	(mm)	(mm)
A9219.7	–	9.70	0.3819	43.0	89.0	9.70
A9219.8	–	9.80	0.3858	43.0	89.0	9.80
A9219.9	–	9.90	0.3898	43.0	89.0	9.90
A92125/64	25/64	9.92	0.3906	48.0	83.0	9.92
A92110.0	–	10.00	0.3937	43.0	89.0	10.00
A92110.2	–	10.20	0.4016	43.0	89.0	10.20
A92110.3	–	10.30	0.4055	43.0	89.0	10.30
A92113/32	13/32	10.32	0.4063	49.0	84.0	10.32
A92110.5	–	10.50	0.4134	43.0	89.0	10.50
A92127/64	27/64	10.72	0.4219	51.0	86.0	10.72
A92110.8	–	10.80	0.4252	47.0	95.0	10.80
A92111.0	–	11.00	0.4331	47.0	95.0	11.00
A9217/16	7/16	11.11	0.4375	52.0	87.0	11.11
A92111.5	–	11.50	0.4528	47.0	95.0	11.50
A92129/64	29/64	11.51	0.4531	54.0	90.0	11.51
A92111.8	–	11.80	0.4646	47.0	95.0	11.80
A92115/32	15/32	11.91	0.4688	54.0	92.0	11.91
A92112.0	–	12.00	0.4724	51.0	102.0	12.00
A92131/64	31/64	12.30	0.4844	56.0	94.0	12.30
A92112.5	–	12.50	0.4921	51.0	102.0	12.50
A9211/2	1/2	12.70	0.5000	57.0	95.0	12.70
A92113.0	–	13.00	0.5118	51.0	102.0	13.00
A92133/64	33/64	13.10	0.5156	60.0	98.0	13.10
A92113.5	–	13.50	0.5315	54.0	107.0	13.50
A92135/64	35/64	13.89	0.5469	64.0	102.0	13.89
A92114.0	–	14.00	0.5512	54.0	107.0	14.00
A9219/16	9/16	14.29	0.5625	64.0	102.0	14.29
A92114.5	–	14.50	0.5709	56.0	111.0	14.50
A92137/64	37/64	14.68	0.5781	67.0	105.0	14.68
A92114.75	–	14.75	0.5807	56.0	111.0	14.75
A92115.0	–	15.00	0.5906	56.0	111.0	15.00
A92119/32	19/32	15.08	0.5938	67.0	105.0	15.08
A92139/64	39/64	15.48	0.6094	70.0	108.0	15.48
A92115.5	–	15.50	0.6102	58.0	115.0	15.50
A9215/8	5/8	15.88	0.6250	70.0	108.0	15.88
A92116.0	–	16.00	0.6299	58.0	115.0	16.00



A002



Foret court en HSS, revêtement TiN en pointe

Foret polyvalent pour le perçage à la main et sur machines. Une pointe spéciale à 118° avec affûtage en croix aide à l'auto-centrage du foret lors du perçage à la main et fournit un trou de taille plus précise. Convient à de nombreux matériaux. Le revêtement TiN en pointe améliore les performances et prolonge la durée de vie de l'outil.

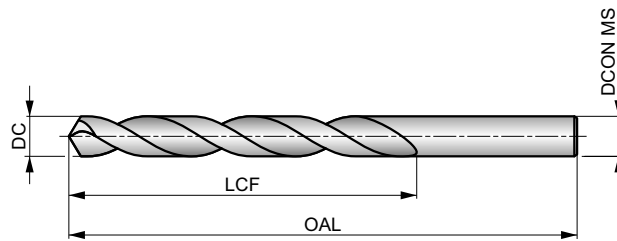

HSS	DIN 338	4xD
118°	TiN-Tip	
λ 20-35°	R	DC h8

Adéquation du groupe de matériaux de la pièce, valeurs de départ pour la vitesse de coupe (m/min) et code Alpha d'avance. Les tableaux d'avances par tour se trouvent à partir de la page 175.

P1.1 ■ 46 J	P1.2 ■ 52 J	P1.3 ■ 54 J	P2.1 ■ 40 J	P2.2 ■ 35 F	P2.3 ■ 31 F	P3.1 ■ 27 F	P3.2 ■ 21 F	P3.3 ■ 18 F	P4.1 ■ 16 F	P4.2 ■ 13 F	P4.3 ■ 11 E	M1.1 ■ 27 F	M1.2 ■ 23 F
M2.1 ■ 24 F	M2.2 ■ 20 F	M3.1 ■ 14 G	M3.2 ■ 12 G	M3.3 ■ 11 G	M4.1 ■ 16 C	K1.1 ■ 40 J	K1.2 ■ 30 E	K1.3 ■ 22 E	K2.1 ■ 34 E	K2.2 ■ 28 E	K2.3 ■ 22 E	K3.1 ■ 30 E	K3.2 ■ 23 E
K3.3 ■ 19 E	K4.1 ■ 28 E	K4.2 ■ 21 E	K4.3 ■ 16 E	K4.4 ■ 13 E	K4.5 ■ 11 E	K5.1 ■ 32 E	K5.2 ■ 24 E	K5.3 ■ 19 E	N1.1 ■ 41 K	N1.2 ■ 31 K	N1.3 ■ 21 J	N2.1 ■ 51 I	N2.2 ■ 46 I
N2.3 ■ 33 I	N3.1 ■ 56 H	N3.2 ■ 33 I	N3.3 ■ 17 G	N4.1 ■ 30 I	N4.2 ■ 50 H	N4.3 ■ 35 F	S1.1 ■ 23 F	S1.2 ■ 13 D	S1.3 ■ 7 B	S2.1 ■ 9 E	S2.2 ■ 4 A	S3.1 ■ 7 E	S3.2 ■ 3 A
S4.1 ■ 5 E	S4.2 ■ 2 A												

DC < 2mm Brillant; DC >= 2mm revêtu TiN en pointe avec affûtage en croix.

Les produits de cette série sont également disponibles en coffret. Voir A087, A089, A094, A095 ou A099.

Produit	DC (inch)	DC (mm)	DC (inch)	LCF (mm)	OAL (mm)	DCON MS (mm)
A0021.0	—	1.00	0.0394	12.0	34.0	1.00
A0021.1	—	1.10	0.0433	14.0	36.0	1.10
A0023/64	3/64	1.19	0.0469	16.0	38.0	1.19
A0021.2	—	1.20	0.0472	16.0	38.0	1.20
A0021.3	—	1.30	0.0512	16.0	38.0	1.30
A0021.4	—	1.40	0.0551	18.0	40.0	1.40
A0021.5	—	1.50	0.0591	18.0	40.0	1.50
A0021/16	1/16	1.59	0.0625	20.0	43.0	1.59
A0021.6	—	1.60	0.0630	20.0	43.0	1.60
A0021.7	—	1.70	0.0669	20.0	43.0	1.70
A0021.8	—	1.80	0.0709	22.0	46.0	1.80
A0021.9	—	1.90	0.0748	22.0	46.0	1.90
A0025/64	5/64	1.98	0.0781	24.0	49.0	1.98
A0022.0	—	2.00	0.0787	24.0	49.0	2.00
A0022.1	—	2.10	0.0827	24.0	49.0	2.10
A0022.2	—	2.20	0.0866	27.0	53.0	2.20
A0022.3	—	2.30	0.0906	27.0	53.0	2.30
A0023/32	3/32	2.38	0.0938	30.0	57.0	2.38
A0022.4	—	2.40	0.0945	30.0	57.0	2.40
A0022.5	—	2.50	0.0984	30.0	57.0	2.50
A0022.6	—	2.60	0.1024	30.0	57.0	2.60
A0022.7	—	2.70	0.1063	33.0	61.0	2.70
A0027/64	7/64	2.78	0.1094	33.0	61.0	2.78
A0022.8	—	2.80	0.1102	33.0	61.0	2.80

Produit	DC (inch)	DC (mm)	DC (inch)	LCF (mm)	OAL (mm)	DCON MS (mm)
A0022.9	—	2.90	0.1142	33.0	61.0	2.90
A0023.0	—	3.00	0.1181	33.0	61.0	3.00
A0023.1	—	3.10	0.1220	36.0	65.0	3.10
A0021/8	1/8	3.18	0.1250	36.0	65.0	3.18
A0023.2	—	3.20	0.1260	36.0	65.0	3.20
A0023.25	—	3.25	0.1280	36.0	65.0	3.25
A0023.3	—	3.30	0.1299	36.0	65.0	3.30
A0023.4	—	3.40	0.1339	39.0	70.0	3.40
A0023.5	—	3.50	0.1378	39.0	70.0	3.50
A0029/64	9/64	3.57	0.1406	39.0	70.0	3.57
A0023.6	—	3.60	0.1417	39.0	70.0	3.60
A0023.7	—	3.70	0.1457	39.0	70.0	3.70
A0023.8	—	3.80	0.1496	43.0	75.0	3.80
A0023.9	—	3.90	0.1535	43.0	75.0	3.90
A0025/32	5/32	3.97	0.1563	43.0	75.0	3.97
A0024.0	—	4.00	0.1575	43.0	75.0	4.00
A0024.1	—	4.10	0.1614	43.0	75.0	4.10
A0024.2	—	4.20	0.1654	43.0	75.0	4.20
A0024.3	—	4.30	0.1693	47.0	80.0	4.30
A00211/64	11/64	4.37	0.1719	47.0	80.0	4.37
A0024.4	—	4.40	0.1732	47.0	80.0	4.40
A0024.5	—	4.50	0.1772	47.0	80.0	4.50
A0024.6	—	4.60	0.1811	47.0	80.0	4.60
A0024.7	—	4.70	0.1850	47.0	80.0	4.70



A002S



Foret court en HSS, revêtement TiN en pointe

Foret polyvalent pour le perçage à la main et sur machines, il est vendu à l'unité ou par 2 pièces (dia <=5 mm). Une pointe spéciale à 118° avec affûtage en croix aide à l'auto-centrage du foret lors du perçage à la main et fournit un trou de taille plus précise. Convient à de nombreux matériaux. Le revêtement TiN en pointe améliore les performances et prolonge la durée de vie de l'outil.

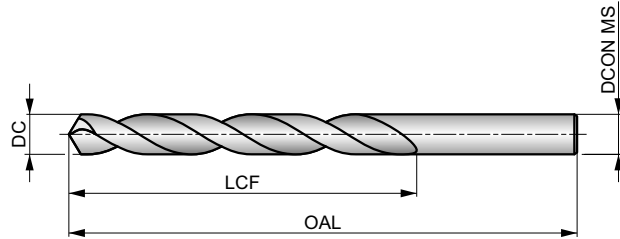

HSS	DIN 338	4xD
118°	TiN-Tip	
λ 20-35°	R	DC h8

Adéquation du groupe de matériaux de la pièce, valeurs de départ pour la vitesse de coupe (m/min) et code Alpha d'avance. Les tableaux d'avances par tour se trouvent à partir de la page 175.

P1.1 ■ 46 J	P1.2 ■ 52 J	P1.3 ■ 54 J	P2.1 ■ 40 J	P2.2 ■ 35 F	P2.3 ■ 31 F	P3.1 ■ 27 F	P3.2 ■ 21 F	P3.3 ■ 18 F	P4.1 ■ 16 F	P4.2 ■ 13 F	P4.3 ■ 11 E	M1.1 ■ 27 F	M1.2 ■ 23 F
M2.1 ■ 24 F	M2.2 ■ 20 F	M3.1 ■ 14 G	M3.2 ■ 12 G	M3.3 ■ 11 G	M4.1 ■ 16 C	K1.1 ■ 40 J	K1.2 ■ 30 E	K1.3 ■ 22 E	K2.1 ■ 34 E	K2.2 ■ 28 E	K2.3 ■ 22 E	K3.1 ■ 30 E	K3.2 ■ 23 E
K3.3 ■ 19 E	K4.1 ■ 28 E	K4.2 ■ 21 E	K4.3 ■ 16 E	K4.4 ■ 13 E	K4.5 ■ 11 E	K5.1 ■ 32 E	K5.2 ■ 24 E	K5.3 ■ 19 E	N1.1 ■ 41 K	N1.2 ■ 31 K	N1.3 ■ 21 J	N2.1 ■ 51 I	N2.2 ■ 46 I
N2.3 ■ 33 I	N3.1 ■ 56 H	N3.2 ■ 33 I	N3.3 ■ 17 G	N4.1 ■ 30 I	N4.2 ■ 50 H	N4.3 ■ 35 F	S1.1 ■ 23 F	S1.2 ■ 13 D	S1.3 ■ 7 B	S2.1 ■ 9 E	S2.2 ■ 4 A	S3.1 ■ 7 E	S3.2 ■ 3 A
S4.1 ■ 5 E	S4.2 ■ 2 A												

DC <= 5mm vendu par 2.

Produit	DC	DC	DC	LCF	OAL	DCON MS
	(inch)	(mm)	(inch)	(mm)	(mm)	(mm)
A002S2.0	-	2.00	0.0787	24.0	49.0	2.00
A002S2.5	-	2.50	0.0984	30.0	57.0	2.50
A002S3.0	-	3.00	0.1181	33.0	61.0	3.00
A002S1/8	1/8	3.18	0.1250	36.0	65.0	3.18
A002S3.2	-	3.20	0.1260	36.0	65.0	3.20
A002S3.3	-	3.30	0.1299	36.0	65.0	3.30
A002S3.5	-	3.50	0.1378	39.0	70.0	3.50
A002S5/32	5/32	3.97	0.1563	43.0	75.0	3.97
A002S4.0	-	4.00	0.1575	43.0	75.0	4.00
A002S4.1	-	4.10	0.1614	43.0	75.0	4.10
A002S4.2	-	4.20	0.1654	43.0	75.0	4.20
A002S4.5	-	4.50	0.1772	47.0	80.0	4.50
A002S3/16	3/16	4.76	0.1875	52.0	86.0	4.76
A002S5.0	-	5.00	0.1969	52.0	86.0	5.00
A002S13/64	13/64	5.16	0.2031	52.0	86.0	5.16
A002S5.5	-	5.50	0.2165	57.0	93.0	5.50
A002S7/32	7/32	5.56	0.2188	57.0	93.0	5.56
A002S6.0	-	6.00	0.2362	57.0	93.0	6.00
A002S1/4	1/4	6.35	0.2500	63.0	101.0	6.35
A002S6.5	-	6.50	0.2559	63.0	101.0	6.50

Produit	DC	DC	DC	LCF	OAL	DCON MS
	(inch)	(mm)	(inch)	(mm)	(mm)	(mm)
A002S17/64	17/64	6.75	0.2656	69.0	109.0	6.75
A002S6.8	-	6.80	0.2677	69.0	109.0	6.80
A002S7.0	-	7.00	0.2756	69.0	109.0	7.00
A002S7.5	-	7.50	0.2953	69.0	109.0	7.50
A002S5/16	5/16	7.94	0.3125	75.0	117.0	7.94
A002S8.0	-	8.00	0.3150	75.0	117.0	8.00
A002S8.2	-	8.20	0.3228	75.0	117.0	8.20
A002S8.5	-	8.50	0.3346	75.0	117.0	8.50
A002S9.0	-	9.00	0.3543	81.0	125.0	9.00
A002S9.5	-	9.50	0.3740	81.0	125.0	9.50
A002S3/8	3/8	9.52	0.3750	87.0	133.0	9.52
A002S10.0	-	10.00	0.3937	87.0	133.0	10.00
A002S10.2	-	10.20	0.4016	87.0	133.0	10.20
A002S10.5	-	10.50	0.4134	87.0	133.0	10.50
A002S11.0	-	11.00	0.4331	94.0	142.0	11.00
A002S11.5	-	11.50	0.4528	94.0	142.0	11.50
A002S12.0	-	12.00	0.4724	101.0	151.0	12.00
A002S12.5	-	12.50	0.4921	101.0	151.0	12.50
A002S1/2	1/2	12.70	0.5000	101.0	151.0	12.70
A002S13.0	-	13.00	0.5118	101.0	151.0	13.00



A100



Foret court en HSS, finition avec traitement vapeur

Un excellent foret polyvalent avec une pointe conventionnelle de 118° qui offre de la résistance et est facile à réaffûter, ce qui le rend très rentable. Utilisable pour le perçage manuel et sur machines. La finition avec traitement vapeur retient le fluide de coupe et empêche le collage des copeaux sur l'outil. Convient à de nombreux matériaux.

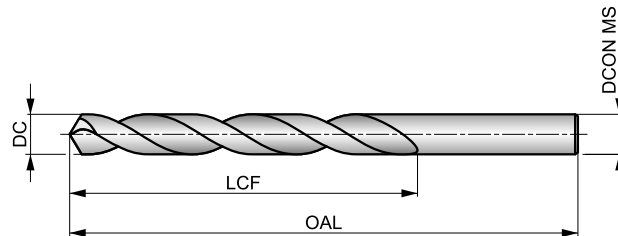

HSS	DIN 338	4xD
118°	ST	
λ 20-35°	R	DC h8

Adéquation du groupe de matériaux de la pièce, valeurs de départ pour la vitesse de coupe (m/min) et code Alpha d'avance. Les tableaux d'avances par tour se trouvent à partir de la page 175.

P1.1 ■ 33 H	P1.2 ■ 37 H	P1.3 ■ 38 H	P2.1 ■ 28 H	P2.2 ■ 25 F	P2.3 ■ 22 E	P3.1 ■ 19 F	P3.2 ■ 15 F	P3.3 ■ 13 E	P4.1 ■ 11 F	P4.2 ■ 10 E	P4.3 ■ 8 D	M1.1 ■ 21 E	M1.2 ■ 17 E
M2.1 ■ 18 E	M2.2 ■ 15 E	M3.1 ■ 9 G	M3.2 ■ 8 G	M3.3 ■ 7 G	M4.1 ■ 9 C	K1.1 ■ 30 H	K1.2 ■ 22 F	K1.3 ■ 17 F	K2.1 ■ 25 E	K2.2 ■ 20 E	K2.3 ■ 16 E	K3.1 ■ 22 E	K3.2 ■ 17 E
K3.3 ■ 13 E	K4.1 ■ 20 E	K4.2 ■ 15 E	K4.3 ■ 11 E	K4.4 ■ 10 E	K4.5 ■ 8 E	K5.1 ■ 23 E	K5.2 ■ 17 E	K5.3 ■ 13 E	N1.1 ■ 33 J	N1.2 ■ 25 J	N1.3 ■ 17 I	N2.1 ■ 42 H	N2.2 ■ 37 H
N2.3 ■ 27 H	N3.1 ■ 59 H	N3.2 ■ 35 I	N3.3 ■ 18 G	N4.1 ■ 30 J	N4.2 ■ 28 H	N4.3 ■ 14 F	S1.1 ■ 23 E	S1.2 ■ 12 D	S1.3 ■ 6 B	S2.1 ■ 8 E	S2.2 ■ 4 A	S3.1 ■ 6 E	S3.2 ■ 3 A
S4.1 ■ 5 E	S4.2 ■ 2 A												

DC ≤ 1mm; 3/64"; N60. Brillant.

Les produits de cette série sont également disponibles en coffret. Voir A190, A191 ou A199.

Produit	DC	DC	DC	LCF	OAL	DCON MS	Produit	DC	DC	DC	LCF	OAL	DCON MS
	(inch)	(mm)	(inch)	(mm)	(mm)	(mm)		(inch)	(mm)	(inch)	(mm)	(mm)	(mm)
A100.2	–	0.20	0.0079	2.5	19.0	0.20	A100.6	–	0.60	0.0236	7.0	24.0	0.60
A100.25	–	0.25	0.0098	3.0	19.0	0.25	A100N73	N73	0.61	0.0240	8.0	26.0	0.61
A100.3	–	0.30	0.0118	3.0	19.0	0.30	A100.62	–	0.62	0.0244	8.0	26.0	0.62
A100.32	–	0.32	0.0126	4.0	19.0	0.32	A100N72	N72	0.64	0.0250	8.0	26.0	0.64
A100N80	N80	0.34	0.0135	4.0	19.0	0.34	A100.65	–	0.65	0.0256	8.0	26.0	0.65
A100.35	–	0.35	0.0138	4.0	19.0	0.35	A100N71	N71	0.66	0.0260	8.0	26.0	0.66
A100N79	N79	0.37	0.0145	4.0	19.0	0.37	A100.68	–	0.68	0.0268	9.0	28.0	0.68
A100.38	–	0.38	0.0150	4.0	19.0	0.38	A100.7	–	0.70	0.0276	9.0	28.0	0.70
A1001/64	1/64	0.40	0.0156	5.0	20.0	0.40	A100N70	N70	0.71	0.0280	9.0	28.0	0.71
A100.4	–	0.40	0.0157	5.0	20.0	0.40	A100.72	–	0.72	0.0283	9.0	28.0	0.72
A100N78	N78	0.41	0.0160	5.0	20.0	0.41	A100N69	N69	0.74	0.0292	9.0	28.0	0.74
A100.42	–	0.42	0.0165	5.0	20.0	0.42	A100.75	–	0.75	0.0295	9.0	28.0	0.75
A100.45	–	0.45	0.0177	5.0	20.0	0.45	A100.78	–	0.78	0.0307	10.0	30.0	0.78
A100N77	N77	0.46	0.0180	5.0	20.0	0.46	A1001/32	1/32	0.79	0.0313	10.0	30.0	0.79
A100.48	–	0.48	0.0189	5.0	20.0	0.48	A100N68	N68	0.79	0.0310	10.0	30.0	0.79
A100.5	–	0.50	0.0197	6.0	22.0	0.50	A100.8	–	0.80	0.0315	10.0	30.0	0.80
A100N76	N76	0.51	0.0200	6.0	22.0	0.51	A100N67	N67	0.81	0.0320	10.0	30.0	0.81
A100.52	–	0.52	0.0205	6.0	22.0	0.52	A100.82	–	0.82	0.0323	10.0	30.0	0.82
A100N75	N75	0.53	0.0210	6.0	22.0	0.53	A100N66	N66	0.84	0.0330	10.0	30.0	0.84
A100.55	–	0.55	0.0217	7.0	24.0	0.55	A100.85	–	0.85	0.0335	10.0	30.0	0.85
A100N74	N74	0.57	0.0225	7.0	24.0	0.57	A100.88	–	0.88	0.0346	11.0	32.0	0.88
A100.58	–	0.58	0.0228	7.0	24.0	0.58	A100N65	N65	0.89	0.0350	11.0	32.0	0.89



Produit	DC	DC	DC	LCF	OAL	DCON MS
	(inch)	(mm)	(inch)	(mm)	(mm)	(mm)
A100.9	—	0.90	0.0354	11.0	32.0	0.90
A100N64	N64	0.91	0.0360	11.0	32.0	0.91
A100.92	—	0.92	0.0362	11.0	32.0	0.92
A100N63	N63	0.94	0.0370	11.0	32.0	0.94
A100.95	—	0.95	0.0374	11.0	32.0	0.95
A100N62	N62	0.97	0.0380	12.0	34.0	0.97
A100.98	—	0.98	0.0386	12.0	34.0	0.98
A100N61	N61	0.99	0.0390	12.0	34.0	0.99
A1001.0	—	1.00	0.0394	12.0	34.0	1.00
A100N60	N60	1.02	0.0400	12.0	34.0	1.02
A100N59	N59	1.04	0.0410	12.0	34.0	1.04
A1001.05	—	1.05	0.0413	12.0	34.0	1.05
A100N58	N58	1.07	0.0420	14.0	36.0	1.07
A100N57	N57	1.09	0.0430	14.0	36.0	1.09
A1001.1	—	1.10	0.0433	14.0	36.0	1.10
A1001.15	—	1.15	0.0453	14.0	36.0	1.15
A100N56	N56	1.18	0.0465	14.0	36.0	1.18
A1003/64	3/64	1.19	0.0469	16.0	38.0	1.19
A1001.2	—	1.20	0.0472	16.0	38.0	1.20
A1001.25	—	1.25	0.0492	16.0	38.0	1.25
A1001.3	—	1.30	0.0512	16.0	38.0	1.30
A100N55	N55	1.32	0.0520	16.0	38.0	1.32
A1001.35	—	1.35	0.0531	18.0	40.0	1.35
A1001.4	—	1.40	0.0551	18.0	40.0	1.40
A100N54	N54	1.40	0.0550	18.0	40.0	1.40
A1001.45	—	1.45	0.0571	18.0	40.0	1.45
A1001.5	—	1.50	0.0591	18.0	40.0	1.50
A100N53	N53	1.51	0.0595	20.0	43.0	1.51
A1001.55	—	1.55	0.0610	20.0	43.0	1.55
A1001/16	1/16	1.59	0.0625	20.0	43.0	1.59
A1001.6	—	1.60	0.0630	20.0	43.0	1.60
A100N52	N52	1.61	0.0635	20.0	43.0	1.61
A1001.65	—	1.65	0.0650	20.0	43.0	1.65
A1001.7	—	1.70	0.0669	20.0	43.0	1.70
A100N51	N51	1.70	0.0670	22.0	46.0	1.70
A1001.75	—	1.75	0.0689	22.0	46.0	1.75
A100N50	N50	1.78	0.0700	22.0	46.0	1.78
A1001.8	—	1.80	0.0709	22.0	46.0	1.80
A1001.85	—	1.85	0.0728	22.0	46.0	1.85
A100N49	N49	1.85	0.0730	22.0	46.0	1.85
A1001.9	—	1.90	0.0748	22.0	46.0	1.90
A100N48	N48	1.93	0.0760	24.0	49.0	1.93
A1001.95	—	1.95	0.0768	24.0	49.0	1.95
A1005/64	5/64	1.98	0.0781	24.0	49.0	1.98
A100N47	N47	1.99	0.0785	24.0	49.0	1.99
A1002.0	—	2.00	0.0787	24.0	49.0	2.00
A1002.05	—	2.05	0.0807	24.0	49.0	2.05
A100N46	N46	2.06	0.0810	24.0	49.0	2.06
A100N45	N45	2.08	0.0820	24.0	49.0	2.08
A1002.1	—	2.10	0.0827	24.0	49.0	2.10
A1002.15	—	2.15	0.0846	27.0	53.0	2.15
A100N44	N44	2.18	0.0860	27.0	53.0	2.18
A1002.2	—	2.20	0.0866	27.0	53.0	2.20
A1002.25	—	2.25	0.0886	27.0	53.0	2.25
A100N43	N43	2.26	0.0890	27.0	53.0	2.26
A1002.3	—	2.30	0.0906	27.0	53.0	2.30
A1002.35	—	2.35	0.0925	27.0	53.0	2.35
A1003/32	3/32	2.38	0.0938	30.0	57.0	2.38
A100N42	N42	2.38	0.0935	30.0	57.0	2.38
A1002.4	—	2.40	0.0945	30.0	57.0	2.40
A100N41	N41	2.44	0.0960	30.0	57.0	2.44
A1002.45	—	2.45	0.0965	30.0	57.0	2.45

Produit	DC	DC	DC	LCF	OAL	DCON MS
	(inch)	(mm)	(inch)	(mm)	(mm)	(mm)
A100N40	N40	2.49	0.0980	30.0	57.0	2.49
A1002.5	—	2.50	0.0984	30.0	57.0	2.50
A100N39	N39	2.53	0.0995	30.0	57.0	2.53
A1002.55	—	2.55	0.1004	30.0	57.0	2.55
A100N38	N38	2.58	0.1015	30.0	57.0	2.58
A1002.6	—	2.60	0.1024	30.0	57.0	2.60
A100N37	N37	2.64	0.1040	30.0	57.0	2.64
A1002.65	—	2.65	0.1043	30.0	57.0	2.65
A1002.7	—	2.70	0.1063	33.0	61.0	2.70
A100N36	N36	2.71	0.1065	33.0	61.0	2.71
A1002.75	—	2.75	0.1083	33.0	61.0	2.75
A1007/64	7/64	2.78	0.1094	33.0	61.0	2.78
A100N35	N35	2.79	0.1100	33.0	61.0	2.79
A1002.8	—	2.80	0.1102	33.0	61.0	2.80
A100N34	N34	2.82	0.1110	33.0	61.0	2.82
A1002.85	—	2.85	0.1122	33.0	61.0	2.85
A100N33	N33	2.87	0.1130	33.0	61.0	2.87
A1002.9	—	2.90	0.1142	33.0	61.0	2.90
A1002.95	—	2.95	0.1161	33.0	61.0	2.95
A100N32	N32	2.95	0.1160	33.0	61.0	2.95
A1003.0	—	3.00	0.1181	33.0	61.0	3.00
A100N31	N31	3.05	0.1200	36.0	65.0	3.05
A1003.1	—	3.10	0.1220	36.0	65.0	3.10
A1003.15	—	3.15	0.1240	36.0	65.0	3.15
A1001/8	1/8	3.18	0.1250	36.0	65.0	3.18
A1003.2	—	3.20	0.1260	36.0	65.0	3.20
A1003.25	—	3.25	0.1280	36.0	65.0	3.25
A100N30	N30	3.26	0.1285	36.0	65.0	3.26
A1003.3	—	3.30	0.1299	36.0	65.0	3.30
A1003.4	—	3.40	0.1339	39.0	70.0	3.40
A100N29	N29	3.45	0.1360	39.0	70.0	3.45
A1003.5	—	3.50	0.1378	39.0	70.0	3.50
A1009/64	9/64	3.57	0.1406	39.0	70.0	3.57
A100N28	N28	3.57	0.1405	39.0	70.0	3.57
A1003.6	—	3.60	0.1417	39.0	70.0	3.60
A100N27	N27	3.66	0.1440	39.0	70.0	3.66
A1003.7	—	3.70	0.1457	39.0	70.0	3.70
A100N26	N26	3.73	0.1470	39.0	70.0	3.73
A1003.75	—	3.75	0.1476	39.0	70.0	3.75
A1003.8	—	3.80	0.1496	43.0	75.0	3.80
A100N25	N25	3.80	0.1495	43.0	75.0	3.80
A100N24	N24	3.86	0.1520	43.0	75.0	3.86
A1003.9	—	3.90	0.1535	43.0	75.0	3.90
A100N23	N23	3.91	0.1540	43.0	75.0	3.91
A1005/32	5/32	3.97	0.1563	43.0	75.0	3.97
A100N22	N22	3.99	0.1570	43.0	75.0	3.99
A1004.0	—	4.00	0.1575	43.0	75.0	4.00
A100N21	N21	4.04	0.1590	43.0	75.0	4.04
A100N20	N20	4.09	0.1610	43.0	75.0	4.09
A1004.1	—	4.10	0.1614	43.0	75.0	4.10
A1004.2	—	4.20	0.1654	43.0	75.0	4.20
A100N19	N19	4.22	0.1660	43.0	75.0	4.22
A1004.25	—	4.25	0.1673	43.0	75.0	4.25
A1004.3	—	4.30	0.1693	47.0	80.0	4.30
A100N18	N18	4.31	0.1695	47.0	80.0	4.31
A10011/64	11/64	4.37	0.1719	47.0	80.0	4.37
A100N17	N17	4.39	0.1730	47.0	80.0	4.39
A1004.4	—	4.40	0.1732	47.0	80.0	4.40
A1004.5	—	4.50	0.1772	47.0	80.0	4.50
A100N16	N16	4.50	0.1770	47.0	80.0	4.50
A100N15	N15	4.57	0.1800	47.0	80.0	4.57
A1004.6	—	4.60	0.1811	47.0	80.0	4.60



Produit	DC	DC	DC	LCF	OAL	DCON MS
	(inch)	(mm)	(inch)	(mm)	(mm)	(mm)
A100N14	N14	4.62	0.1820	47.0	80.0	4.62
A1004.7	–	4.70	0.1850	47.0	80.0	4.70
A100N13	N13	4.70	0.1850	47.0	80.0	4.70
A1004.75	–	4.75	0.1870	47.0	80.0	4.75
A1003/16	3/16	4.76	0.1875	52.0	86.0	4.76
A1004.8	–	4.80	0.1890	52.0	86.0	4.80
A100N12	N12	4.80	0.1890	52.0	86.0	4.80
A100N11	N11	4.85	0.1910	52.0	86.0	4.85
A1004.9	–	4.90	0.1929	52.0	86.0	4.90
A100N10	N10	4.92	0.1935	52.0	86.0	4.92
A100N9	N9	4.98	0.1960	52.0	86.0	4.98
A1005.0	–	5.00	0.1969	52.0	86.0	5.00
A100N8	N8	5.06	0.1990	52.0	86.0	5.06
A1005.1	–	5.10	0.2008	52.0	86.0	5.10
A100N7	N7	5.11	0.2010	52.0	86.0	5.11
A10013/64	13/64	5.16	0.2031	52.0	86.0	5.16
A100N6	N6	5.18	0.2040	52.0	86.0	5.18
A1005.2	–	5.20	0.2047	52.0	86.0	5.20
A100N5	N5	5.22	0.2055	52.0	86.0	5.22
A1005.25	–	5.25	0.2067	52.0	86.0	5.25
A1005.3	–	5.30	0.2087	52.0	86.0	5.30
A100N4	N4	5.31	0.2090	57.0	93.0	5.31
A1005.4	–	5.40	0.2126	57.0	93.0	5.40
A100N3	N3	5.41	0.2130	57.0	93.0	5.41
A1005.5	–	5.50	0.2165	57.0	93.0	5.50
A1007/32	7/32	5.56	0.2188	57.0	93.0	5.56
A1005.6	–	5.60	0.2205	57.0	93.0	5.60
A100N2	N2	5.61	0.2210	57.0	93.0	5.61
A1005.7	–	5.70	0.2244	57.0	93.0	5.70
A1005.75	–	5.75	0.2264	57.0	93.0	5.75
A100N1	1	5.79	0.2280	57.0	93.0	5.79
A1005.8	–	5.80	0.2283	57.0	93.0	5.80
A1005.9	–	5.90	0.2323	57.0	93.0	5.90
A100A	A	5.94	0.2340	57.0	93.0	5.94
A10015/64	15/64	5.95	0.2344	57.0	93.0	5.95
A1006.0	–	6.00	0.2362	57.0	93.0	6.00
A100B	B	6.03	0.2380	63.0	101.0	6.03
A1006.1	–	6.10	0.2402	63.0	101.0	6.10
A100C	C	6.15	0.2420	63.0	101.0	6.15
A1006.2	–	6.20	0.2441	63.0	101.0	6.20
A1006.25	–	6.25	0.2461	63.0	101.0	6.25
A100D	D	6.25	0.2460	63.0	101.0	6.25
A1006.3	–	6.30	0.2480	63.0	101.0	6.30
A1001/4	1/4	6.35	0.2500	63.0	101.0	6.35
A100E	E	6.35	0.2500	63.0	101.0	6.35
A1006.4	–	6.40	0.2520	63.0	101.0	6.40
A1006.5	–	6.50	0.2559	63.0	101.0	6.50
A100F	F	6.53	0.2570	63.0	101.0	6.53
A1006.6	–	6.60	0.2598	63.0	101.0	6.60
A100G	G	6.63	0.2610	63.0	101.0	6.63
A1006.7	–	6.70	0.2638	63.0	101.0	6.70
A10017/64	17/64	6.75	0.2656	69.0	109.0	6.75
A1006.75	–	6.75	0.2657	69.0	109.0	6.75
A100H	H	6.76	0.2660	69.0	109.0	6.76
A1006.8	–	6.80	0.2677	69.0	109.0	6.80
A1006.9	–	6.90	0.2717	69.0	109.0	6.90
A100I	I	6.91	0.2720	69.0	109.0	6.91
A1007.0	–	7.00	0.2756	69.0	109.0	7.00
A100J	J	7.04	0.2770	69.0	109.0	7.04
A1007.1	–	7.10	0.2795	69.0	109.0	7.10
A1009/32	9/32	7.14	0.2813	69.0	109.0	7.14
A100K	K	7.14	0.2810	69.0	109.0	7.14

Produit	DC	DC	DC	LCF	OAL	DCON MS
	(inch)	(mm)	(inch)	(mm)	(mm)	(mm)
A1007.2	–	7.20	0.2835	69.0	109.0	7.20
A1007.25	–	7.25	0.2854	69.0	109.0	7.25
A1007.3	–	7.30	0.2874	69.0	109.0	7.30
A100L	L	7.37	0.2900	69.0	109.0	7.37
A1007.4	–	7.40	0.2913	69.0	109.0	7.40
A100M	M	7.49	0.2949	69.0	109.0	7.49
A1007.5	–	7.50	0.2953	69.0	109.0	7.50
A10019/64	19/64	7.54	0.2969	75.0	117.0	7.54
A1007.6	–	7.60	0.2992	75.0	117.0	7.60
A100N	N	7.67	0.3020	75.0	117.0	7.67
A1007.7	–	7.70	0.3031	75.0	117.0	7.70
A1007.75	–	7.75	0.3051	75.0	117.0	7.75
A1007.8	–	7.80	0.3071	75.0	117.0	7.80
A1007.9	–	7.90	0.3110	75.0	117.0	7.90
A1005/16	5/16	7.94	0.3125	75.0	117.0	7.94
A1008.0	–	8.00	0.3150	75.0	117.0	8.00
A100O	O	8.03	0.3160	75.0	117.0	8.03
A1008.1	–	8.10	0.3189	75.0	117.0	8.10
A1008.2	–	8.20	0.3228	75.0	117.0	8.20
A100P	P	8.20	0.3230	75.0	117.0	8.20
A1008.25	–	8.25	0.3248	75.0	117.0	8.25
A1008.3	–	8.30	0.3268	75.0	117.0	8.30
A10021/64	21/64	8.33	0.3281	75.0	117.0	8.33
A1008.4	–	8.40	0.3307	75.0	117.0	8.40
A100Q	Q	8.43	0.3320	75.0	117.0	8.43
A1008.5	–	8.50	0.3346	75.0	117.0	8.50
A1008.6	–	8.60	0.3386	81.0	125.0	8.60
A100R	R	8.61	0.3390	81.0	125.0	8.61
A1008.7	–	8.70	0.3425	81.0	125.0	8.70
A10011/32	11/32	8.73	0.3438	81.0	125.0	8.73
A1008.75	–	8.75	0.3445	81.0	125.0	8.75
A1008.8	–	8.80	0.3465	81.0	125.0	8.80
A100S	S	8.84	0.3480	81.0	125.0	8.84
A1008.9	–	8.90	0.3504	81.0	125.0	8.90
A1009.0	–	9.00	0.3543	81.0	125.0	9.00
A100T	T	9.09	0.3580	81.0	125.0	9.09
A1009.1	–	9.10	0.3583	81.0	125.0	9.10
A10023/64	23/64	9.13	0.3594	81.0	125.0	9.13
A1009.2	–	9.20	0.3622	81.0	125.0	9.20
A1009.25	–	9.25	0.3642	81.0	125.0	9.25
A1009.3	–	9.30	0.3661	81.0	125.0	9.30
A100U	U	9.35	0.3680	81.0	125.0	9.35
A1009.4	–	9.40	0.3701	81.0	125.0	9.40
A1009.5	–	9.50	0.3740	81.0	125.0	9.50
A1003/8	3/8	9.52	0.3750	87.0	133.0	9.52
A100V	V	9.58	0.3770	87.0	133.0	9.58
A1009.6	–	9.60	0.3780	87.0	133.0	9.60
A1009.7	–	9.70	0.3819	87.0	133.0	9.70
A1009.75	–	9.75	0.3839	87.0	133.0	9.75
A1009.8	–	9.80	0.3858	87.0	133.0	9.80
A100W	W	9.80	0.3860	87.0	133.0	9.80
A1009.9	–	9.90	0.3898	87.0	133.0	9.90
A10025/64	25/64	9.92	0.3906	87.0	133.0	9.92
A10010.0	–	10.00	0.3937	87.0	133.0	10.00
A100X	X	10.08	0.3970	87.0	133.0	10.08
A10010.1	–	10.10	0.3976	87.0	133.0	10.10
A10010.2	–	10.20	0.4016	87.0	133.0	10.20
A10010.25	–	10.25	0.4035	87.0	133.0	10.25
A100Y	Y	10.26	0.4040	87.0	133.0	10.26
A10010.3	–	10.30	0.4055	87.0	133.0	10.30
A10013/32	13/32	10.32	0.4063	87.0	133.0	10.32
A10010.4	–	10.40	0.4094	87.0	133.0	10.40



Produit	DC	DC	DC	LCF	OAL	D CON MS
	(inch)	(mm)	(inch)	(mm)	(mm)	(mm)
A100Z	Z	10.49	0.4130	87.0	133.0	10.49
A10010.5	–	10.50	0.4134	87.0	133.0	10.50
A10010.6	–	10.60	0.4173	87.0	133.0	10.60
A10010.7	–	10.70	0.4213	94.0	142.0	10.70
A10027/64	27/64	10.72	0.4219	94.0	142.0	10.72
A10010.75	–	10.75	0.4232	94.0	142.0	10.75
A10010.8	–	10.80	0.4252	94.0	142.0	10.80
A10010.9	–	10.90	0.4291	94.0	142.0	10.90
A10011.0	–	11.00	0.4331	94.0	142.0	11.00
A10011.1	–	11.10	0.4370	94.0	142.0	11.10
A1007/16	7/16	11.11	0.4375	94.0	142.0	11.11
A10011.2	–	11.20	0.4409	94.0	142.0	11.20
A10011.25	–	11.25	0.4429	94.0	142.0	11.25
A10011.3	–	11.30	0.4449	94.0	142.0	11.30
A10011.4	–	11.40	0.4488	94.0	142.0	11.40
A10011.5	–	11.50	0.4528	94.0	142.0	11.50
A10029/64	29/64	11.51	0.4531	94.0	142.0	11.51
A10011.6	–	11.60	0.4567	94.0	142.0	11.60
A10011.7	–	11.70	0.4606	94.0	142.0	11.70
A10011.75	–	11.75	0.4626	94.0	142.0	11.75
A10011.8	–	11.80	0.4646	94.0	142.0	11.80
A10011.9	–	11.90	0.4685	101.0	151.0	11.90
A10015/32	15/32	11.91	0.4688	101.0	151.0	11.91
A10012.0	–	12.00	0.4724	101.0	151.0	12.00
A10012.1	–	12.10	0.4764	101.0	151.0	12.10
A10012.2	–	12.20	0.4803	101.0	151.0	12.20
A10012.25	–	12.25	0.4823	101.0	151.0	12.25
A10012.3	–	12.30	0.4843	101.0	151.0	12.30
A10031/64	31/64	12.30	0.4844	101.0	151.0	12.30
A10012.4	–	12.40	0.4882	101.0	151.0	12.40
A10012.5	–	12.50	0.4921	101.0	151.0	12.50
A10012.6	–	12.60	0.4961	101.0	151.0	12.60
A10012.7	–	12.70	0.5000	101.0	151.0	12.70
A1001/2	1/2	12.70	0.5000	101.0	151.0	12.70
A10012.75	–	12.75	0.5020	101.0	151.0	12.75
A10012.8	–	12.80	0.5039	101.0	151.0	12.80
A10012.9	–	12.90	0.5079	101.0	151.0	12.90
A10013.0	–	13.00	0.5118	101.0	151.0	13.00
A10033/64	33/64	13.10	0.5156	101.0	151.0	13.10

Produit	DC	DC	DC	LCF	OAL	D CON MS
	(inch)	(mm)	(inch)	(mm)	(mm)	(mm)
A10013.1	–	13.10	0.5157	101.0	151.0	13.10
A10013.2	–	13.20	0.5197	101.0	151.0	13.20
A10013.25	–	13.25	0.5217	108.0	160.0	13.25
A10013.3	–	13.30	0.5236	108.0	160.0	13.30
A10013.4	–	13.40	0.5276	108.0	160.0	13.40
A10017/32	17/32	13.49	0.5313	108.0	160.0	13.49
A10013.5	–	13.50	0.5315	108.0	160.0	13.50
A10013.6	–	13.60	0.5354	108.0	160.0	13.60
A10013.7	–	13.70	0.5394	108.0	160.0	13.70
A10013.75	–	13.75	0.5413	108.0	160.0	13.75
A10013.8	–	13.80	0.5433	108.0	160.0	13.80
A10035/64	35/64	13.89	0.5469	108.0	160.0	13.89
A10013.9	–	13.90	0.5472	108.0	160.0	13.90
A10014.0	–	14.00	0.5512	108.0	160.0	14.00
A10014.25	–	14.25	0.5610	114.0	169.0	14.25
A1009/16	9/16	14.29	0.5625	114.0	169.0	14.29
A10014.5	–	14.50	0.5709	114.0	169.0	14.50
A10037/64	37/64	14.68	0.5781	114.0	169.0	14.68
A10014.75	–	14.75	0.5807	114.0	169.0	14.75
A10015.0	–	15.00	0.5906	114.0	169.0	15.00
A10019/32	19/32	15.08	0.5938	120.0	178.0	15.08
A10015.25	–	15.25	0.6004	120.0	178.0	15.25
A10039/64	39/64	15.48	0.6094	120.0	178.0	15.48
A10015.5	–	15.50	0.6102	120.0	178.0	15.50
A10015.75	–	15.75	0.6201	120.0	178.0	15.75
A1005/8	5/8	15.88	0.6250	120.0	178.0	15.88
A10016.0	–	16.00	0.6299	120.0	178.0	16.00
A10041/64	41/64	16.27	0.6406	125.0	184.0	16.27
A10016.5	–	16.50	0.6496	125.0	184.0	16.50
A10021/32	21/32	16.67	0.6563	125.0	184.0	16.67
A10017.0	–	17.00	0.6693	125.0	184.0	17.00
A10043/64	43/64	17.07	0.6719	130.0	191.0	17.07
A10011/16	11/16	17.46	0.6875	130.0	191.0	17.46
A10017.5	–	17.50	0.6890	130.0	191.0	17.50
A10018.0	–	18.00	0.7087	130.0	191.0	18.00
A10018.5	–	18.50	0.7283	135.0	198.0	18.50
A10019.0	–	19.00	0.7480	135.0	198.0	19.00
A10019.5	–	19.50	0.7677	140.0	205.0	19.50
A10020.0	–	20.00	0.7874	140.0	205.0	20.00



A101



Foret court à gauche en HSS, finition avec traitement vapeur

Foret polyvalent à gauche avec finition traitement vapeur pour le perçage à la main et sur machines. La pointe conventionnelle à 118° est résistante et facile à réaffûter ce qui la rend très rentable. La finition avec traitement vapeur retient le liquide de coupe et empêche le collage des copeaux sur l'outil. Convient pour le perçage de nombreux matériaux.

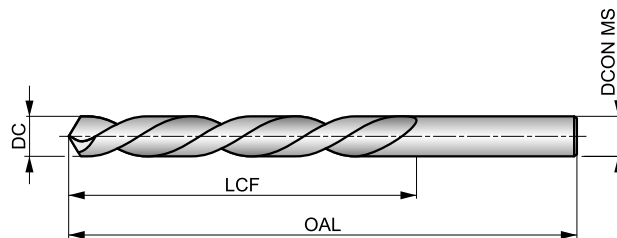

HSS	DIN 338	4xD
118°	ST	
20-35°	L	DC h8

Adéquation du groupe de matériaux de la pièce, valeurs de départ pour la vitesse de coupe (m/min) et code Alpha d'avance. Les tableaux d'avances par tour se trouvent à partir de la page 175.

P1.1 ■ 33 H	P1.2 ■ 37 H	P1.3 ■ 38 H	P2.1 ■ 28 H	P2.2 ■ 25 F	P2.3 ■ 22 E	P3.1 ■ 19 F	P3.2 ■ 15 F	P3.3 ■ 13 E	P4.1 ■ 11 F	P4.2 ■ 10 E	P4.3 ■ 8 D	M1.1 ■ 21 E	M1.2 ■ 17 E
M2.1 ■ 18 E	M2.2 ■ 15 E	M3.1 ■ 9 G	M3.2 ■ 8 G	M3.3 ■ 7 G	M4.1 ■ 9 C	K1.1 ■ 30 H	K1.2 ■ 22 F	K1.3 ■ 17 F	K2.1 ■ 25 E	K2.2 ■ 20 E	K2.3 ■ 16 E	K3.1 ■ 22 E	K3.2 ■ 17 E
K3.3 ■ 13 E	K4.1 ■ 20 E	K4.2 ■ 15 E	K4.3 ■ 11 E	K4.4 ■ 10 E	K4.5 ■ 8 E	K5.1 ■ 23 E	K5.2 ■ 17 E	K5.3 ■ 13 E	N1.1 ■ 33 J	N1.2 ■ 25 J	N1.3 ■ 17 I	N2.1 ■ 42 H	N2.2 ■ 37 H
N2.3 ■ 27 H	N3.1 ■ 59 H	N3.2 ■ 35 I	N3.3 ■ 18 G	N4.1 ■ 30 J	N4.2 ■ 28 H	N4.3 ■ 14 F	S1.1 ■ 23 E	S1.2 ■ 12 D	S1.3 ■ 6 B	S2.1 ■ 8 E	S2.2 ■ 4 A	S3.1 ■ 6 E	S3.2 ■ 3 A
S4.1 ■ 5 E	S4.2 ■ 2 A												

DC <= 3mm Brillant.

Produit	DC	DC	LCF	OAL	DCON MS	Produit	DC	DC	LCF	OAL	DCON MS
	(mm)	(inch)					(mm)	(mm)			
A1011.0	1.00	0.0394	12.0	34.0	1.00	A1013.2	3.20	0.1260	36.0	65.0	3.20
A1011.1	1.10	0.0433	14.0	36.0	1.10	A1013.3	3.30	0.1299	36.0	65.0	3.30
A1011.2	1.20	0.0472	16.0	38.0	1.20	A1013.5	3.50	0.1378	39.0	70.0	3.50
A1011.25	1.25	0.0492	16.0	38.0	1.25	A1013.8	3.80	0.1496	43.0	75.0	3.80
A1011.3	1.30	0.0512	16.0	38.0	1.30	A1014.0	4.00	0.1575	43.0	75.0	4.00
A1011.4	1.40	0.0551	18.0	40.0	1.40	A1014.2	4.20	0.1654	43.0	75.0	4.20
A1011.5	1.50	0.0591	18.0	40.0	1.50	A1014.5	4.50	0.1772	47.0	80.0	4.50
A1011.6	1.60	0.0630	20.0	43.0	1.60	A1014.8	4.80	0.1890	52.0	86.0	4.80
A1011.7	1.70	0.0669	20.0	43.0	1.70	A1015.0	5.00	0.1969	52.0	86.0	5.00
A1011.8	1.80	0.0709	22.0	46.0	1.80	A1015.1	5.10	0.2008	52.0	86.0	5.10
A1011.9	1.90	0.0748	22.0	46.0	1.90	A1015.2	5.20	0.2047	52.0	86.0	5.20
A1012.0	2.00	0.0787	24.0	49.0	2.00	A1015.5	5.50	0.2165	57.0	93.0	5.50
A1012.1	2.10	0.0827	24.0	49.0	2.10	A1016.0	6.00	0.2362	57.0	93.0	6.00
A1012.2	2.20	0.0866	27.0	53.0	2.20	A1016.5	6.50	0.2559	63.0	101.0	6.50
A1012.3	2.30	0.0906	27.0	53.0	2.30	A1017.0	7.00	0.2756	69.0	109.0	7.00
A1012.4	2.40	0.0945	30.0	57.0	2.40	A1017.5	7.50	0.2953	69.0	109.0	7.50
A1012.5	2.50	0.0984	30.0	57.0	2.50	A1018.0	8.00	0.3150	75.0	117.0	8.00
A1012.6	2.60	0.1024	30.0	57.0	2.60	A1018.5	8.50	0.3346	75.0	117.0	8.50
A1012.7	2.70	0.1063	33.0	61.0	2.70	A1019.0	9.00	0.3543	81.0	125.0	9.00
A1012.8	2.80	0.1102	33.0	61.0	2.80	A10110.0	10.00	0.3937	87.0	133.0	10.00
A1012.9	2.90	0.1142	33.0	61.0	2.90	A10111.0	11.00	0.4331	94.0	142.0	11.00
A1013.0	3.00	0.1181	33.0	61.0	3.00	A10112.0	12.00	0.4724	101.0	151.0	12.00



A108



Foret court en HSS, finition avec traitement vapeur (conçu pour l'acier inoxydable)

Foret premier choix pour le perçage de l'acier inoxydable avec des applications manuelles mais peut également être utilisé efficacement sur machines. Sa pointe à 135° avec affûtage en croix facilite l'auto-centrage et réduit les forces de coupe. La finition avec traitement vapeur aide à empêcher le matériau de la pièce de coller aux arêtes de coupe.

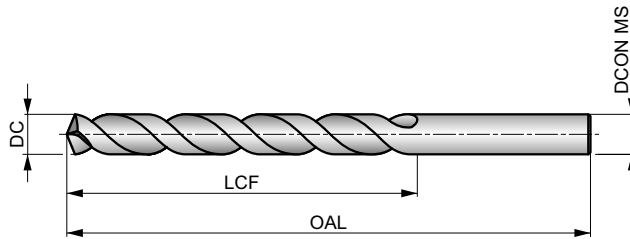

HSS	DIN 338	4xD
135°	ST	
λ > 35°	R	DC h8

Adéquation du groupe de matériaux de la pièce, valeurs de départ pour la vitesse de coupe (m/min) et code Alpha d'avance. Les tableaux d'avances par tour se trouvent à partir de la page 175.

P1.1 33 I	P1.2 37 I	P1.3 38 I	P2.1 28 I	P2.2 25 G	P2.3 22 E	P3.1 19 F	P3.2 15 F	P3.3 13 E	P4.1 11 F	P4.2 10 E	P4.3 8 D	M1.1 21 E	M1.2 17 E
M2.1 18 E	M2.2 15 E	M3.1 10 G	M3.2 9 G	M3.3 8 G	M4.1 10 D	K1.1 30 H	K1.2 22 F	K1.3 17 F	K2.1 25 E	K2.2 20 E	K2.3 16 E	K3.1 22 E	K3.2 17 E
K3.3 13 E	K4.1 20 E	K4.2 15 E	K4.3 11 E	K4.4 10 E	K4.5 8 E	K5.1 23 E	K5.2 17 E	K5.3 13 E	N1.1 33 J	N1.2 25 J	N1.3 17 I	N2.1 42 H	N2.2 37 H
N2.3 27 H	N3.1 59 H	N3.2 35 I	N3.3 18 G	N4.1 30 J	N4.2 28 H	N4.3 14 F	S1.1 25 G	S1.2 16 E	S1.3 7 B	S2.1 9 G	S2.2 8 E	S3.1 7 G	S3.2 6 E
S4.1 5 G	S4.2 5 E												

DC > 1.5mm (1/16") avec affûtage en croix.

Les produits de cette série sont également disponibles en coffret. Voir A188.

Produit	DC (inch)	DC (mm)	DC (inch)	LCF (mm)	OAL (mm)	DCON MS (mm)
A1081.0	—	1.00	0.0394	12.0	34.0	1.00
A1081.1	—	1.10	0.0433	14.0	36.0	1.10
A1081.2	—	1.20	0.0472	16.0	38.0	1.20
A1081.3	—	1.30	0.0512	16.0	38.0	1.30
A1081.4	—	1.40	0.0551	18.0	40.0	1.40
A1081.5	—	1.50	0.0591	18.0	40.0	1.50
A1081/16	1/16	1.59	0.0625	20.0	43.0	1.59
A1081.6	—	1.60	0.0630	20.0	43.0	1.60
A1081.7	—	1.70	0.0669	20.0	43.0	1.70
A1081.8	—	1.80	0.0709	22.0	46.0	1.80
A1081.9	—	1.90	0.0748	22.0	46.0	1.90
A1085/64	5/64	1.98	0.0781	24.0	49.0	1.98
A1082.0	—	2.00	0.0787	24.0	49.0	2.00
A1082.1	—	2.10	0.0827	24.0	49.0	2.10
A1082.2	—	2.20	0.0866	27.0	53.0	2.20
A1082.3	—	2.30	0.0906	27.0	53.0	2.30
A1083/32	3/32	2.38	0.0938	30.0	57.0	2.38
A1082.4	—	2.40	0.0945	30.0	57.0	2.40
A1082.5	—	2.50	0.0984	30.0	57.0	2.50
A1082.6	—	2.60	0.1024	30.0	57.0	2.60
A1082.7	—	2.70	0.1063	33.0	61.0	2.70
A1087/64	7/64	2.78	0.1094	33.0	61.0	2.78

Produit	DC (inch)	DC (mm)	DC (inch)	LCF (mm)	OAL (mm)	DCON MS (mm)
A1082.8	—	2.80	0.1102	33.0	61.0	2.80
A1082.9	—	2.90	0.1142	33.0	61.0	2.90
A1083.0	—	3.00	0.1181	33.0	61.0	3.00
A1083.1	—	3.10	0.1220	36.0	65.0	3.10
A1081/8	1/8	3.18	0.1250	36.0	65.0	3.18
A1083.2	—	3.20	0.1260	36.0	65.0	3.20
A1083.3	—	3.30	0.1299	36.0	65.0	3.30
A1083.4	—	3.40	0.1339	39.0	70.0	3.40
A1083.5	—	3.50	0.1378	39.0	70.0	3.50
A1089/64	9/64	3.57	0.1406	39.0	70.0	3.57
A1083.6	—	3.60	0.1417	39.0	70.0	3.60
A1083.7	—	3.70	0.1457	39.0	70.0	3.70
A1083.8	—	3.80	0.1496	43.0	75.0	3.80
A1083.9	—	3.90	0.1535	43.0	75.0	3.90
A1085/32	5/32	3.97	0.1563	43.0	75.0	3.97
A1084.0	—	4.00	0.1575	43.0	75.0	4.00
A1084.1	—	4.10	0.1614	43.0	75.0	4.10
A1084.2	—	4.20	0.1654	43.0	75.0	4.20
A1084.3	—	4.30	0.1693	47.0	80.0	4.30
A10811/64	11/64	4.37	0.1719	47.0	80.0	4.37
A1084.4	—	4.40	0.1732	47.0	80.0	4.40
A1084.5	—	4.50	0.1772	47.0	80.0	4.50



Produit	DC	DC	DC	LCF	OAL	DCON MS
	(inch)	(mm)	(inch)	(mm)	(mm)	(mm)
A1084.6	–	4.60	0.1811	47.0	80.0	4.60
A1084.7	–	4.70	0.1850	47.0	80.0	4.70
A1083/16	3/16	4.76	0.1875	52.0	86.0	4.76
A1084.8	–	4.80	0.1890	52.0	86.0	4.80
A1084.9	–	4.90	0.1929	52.0	86.0	4.90
A108N10	N10	4.92	0.1935	52.0	86.0	4.92
A1085.0	–	5.00	0.1969	52.0	86.0	5.00
A1085.1	–	5.10	0.2008	52.0	86.0	5.10
A10813/64	13/64	5.16	0.2031	52.0	86.0	5.16
A1085.2	–	5.20	0.2047	52.0	86.0	5.20
A1085.3	–	5.30	0.2087	52.0	86.0	5.30
A1085.4	–	5.40	0.2126	57.0	93.0	5.40
A1085.5	–	5.50	0.2165	57.0	93.0	5.50
A1087/32	7/32	5.56	0.2188	57.0	93.0	5.56
A1085.6	–	5.60	0.2205	57.0	93.0	5.60
A1085.7	–	5.70	0.2244	57.0	93.0	5.70
A1085.8	–	5.80	0.2283	57.0	93.0	5.80
A1085.9	–	5.90	0.2323	57.0	93.0	5.90
A10815/64	15/64	5.95	0.2344	57.0	93.0	5.95
A1086.0	–	6.00	0.2362	57.0	93.0	6.00
A1086.1	–	6.10	0.2402	63.0	101.0	6.10
A1086.2	–	6.20	0.2441	63.0	101.0	6.20
A1086.3	–	6.30	0.2480	63.0	101.0	6.30
A1081/4	1/4	6.35	0.2500	63.0	101.0	6.35
A1086.4	–	6.40	0.2520	63.0	101.0	6.40
A1086.5	–	6.50	0.2559	63.0	101.0	6.50
A1086.6	–	6.60	0.2598	63.0	101.0	6.60
A1086.7	–	6.70	0.2638	63.0	101.0	6.70
A10817/64	17/64	6.75	0.2656	69.0	109.0	6.75
A1086.8	–	6.80	0.2677	69.0	109.0	6.80
A1086.9	–	6.90	0.2717	69.0	109.0	6.90
A1087.0	–	7.00	0.2756	69.0	109.0	7.00
A1087.1	–	7.10	0.2795	69.0	109.0	7.10
A1089/32	9/32	7.14	0.2813	69.0	109.0	7.14
A1087.2	–	7.20	0.2835	69.0	109.0	7.20
A1087.3	–	7.30	0.2874	69.0	109.0	7.30
A1087.4	–	7.40	0.2913	69.0	109.0	7.40
A1087.5	–	7.50	0.2953	69.0	109.0	7.50
A10819/64	19/64	7.54	0.2969	75.0	117.0	7.54
A1087.6	–	7.60	0.2992	75.0	117.0	7.60
A1087.7	–	7.70	0.3031	75.0	117.0	7.70
A1087.8	–	7.80	0.3071	75.0	117.0	7.80
A1087.9	–	7.90	0.3110	75.0	117.0	7.90
A1085/16	5/16	7.94	0.3125	75.0	117.0	7.94
A1088.0	–	8.00	0.3150	75.0	117.0	8.00
A1088.1	–	8.10	0.3189	75.0	117.0	8.10
A1088.2	–	8.20	0.3228	75.0	117.0	8.20
A1088.3	–	8.30	0.3268	75.0	117.0	8.30

Produit	DC	DC	DC	LCF	OAL	DCON MS
	(inch)	(mm)	(inch)	(mm)	(mm)	(mm)
A10821/64	21/64	8.33	0.3281	75.0	117.0	8.33
A1088.4	–	8.40	0.3307	75.0	117.0	8.40
A1088.5	–	8.50	0.3346	75.0	117.0	8.50
A1088.6	–	8.60	0.3386	81.0	125.0	8.60
A1088.7	–	8.70	0.3425	81.0	125.0	8.70
A10811/32	11/32	8.73	0.3438	81.0	125.0	8.73
A1088.8	–	8.80	0.3465	81.0	125.0	8.80
A1088.9	–	8.90	0.3504	81.0	125.0	8.90
A1089.0	–	9.00	0.3543	81.0	125.0	9.00
A1089.1	–	9.10	0.3583	81.0	125.0	9.10
A10823/64	23/64	9.13	0.3594	81.0	125.0	9.13
A1089.2	–	9.20	0.3622	81.0	125.0	9.20
A1089.3	–	9.30	0.3661	81.0	125.0	9.30
A1089.4	–	9.40	0.3701	81.0	125.0	9.40
A1089.5	–	9.50	0.3740	81.0	125.0	9.50
A1083/8	3/8	9.52	0.3750	87.0	133.0	9.52
A1089.6	–	9.60	0.3780	87.0	133.0	9.60
A1089.7	–	9.70	0.3819	87.0	133.0	9.70
A1089.8	–	9.80	0.3858	87.0	133.0	9.80
A1089.9	–	9.90	0.3898	87.0	133.0	9.90
A10825/64	25/64	9.92	0.3906	87.0	133.0	9.92
A10810.0	–	10.00	0.3937	87.0	133.0	10.00
A10810.2	–	10.20	0.4016	87.0	133.0	10.20
A10813/32	13/32	10.32	0.4063	87.0	133.0	10.32
A10810.5	–	10.50	0.4134	87.0	133.0	10.50
A10827/64	27/64	10.72	0.4219	94.0	142.0	10.72
A10810.8	–	10.80	0.4252	94.0	142.0	10.80
A10811.0	–	11.00	0.4331	94.0	142.0	11.00
A1087/16	7/16	11.11	0.4375	94.0	142.0	11.11
A10811.5	–	11.50	0.4528	94.0	142.0	11.50
A10829/64	29/64	11.51	0.4531	94.0	142.0	11.51
A10811.8	–	11.80	0.4646	94.0	142.0	11.80
A10815/32	15/32	11.91	0.4688	101.0	151.0	11.91
A10812.0	–	12.00	0.4724	101.0	151.0	12.00
A10812.2	–	12.20	0.4803	101.0	151.0	12.20
A10831/64	31/64	12.30	0.4844	101.0	151.0	12.30
A10812.5	–	12.50	0.4921	101.0	151.0	12.50
A1081/2	1/2	12.70	0.5000	101.0	151.0	12.70
A10812.8	–	12.80	0.5039	101.0	151.0	12.80
A10812.9	–	12.90	0.5079	101.0	151.0	12.90
A10813.0	–	13.00	0.5118	101.0	151.0	13.00
A10813.5	–	13.50	0.5315	108.0	160.0	13.50
A10814.0	–	14.00	0.5512	108.0	160.0	14.00
A10814.5	–	14.50	0.5709	114.0	169.0	14.50
A10815.0	–	15.00	0.5906	114.0	169.0	15.00
A10815.25	–	15.25	0.6004	120.0	178.0	15.25
A10815.5	–	15.50	0.6102	120.0	178.0	15.50
A10816.0	–	16.00	0.6299	120.0	178.0	16.00



A147



Foret court en HSS-E (5% cobalt), finition brillante (conçu pour l'acier inoxydable)

Foret polyvalent et résistant qui répond à toutes les exigences de perçage sur machines dans les aciers inoxydables, mais qui peut également être utilisé pour les opérations à la main. Sa pointe à 130° avec affûtage en croix aide à l'auto-centrage et réduit les forces de coupe. Finition brillante.

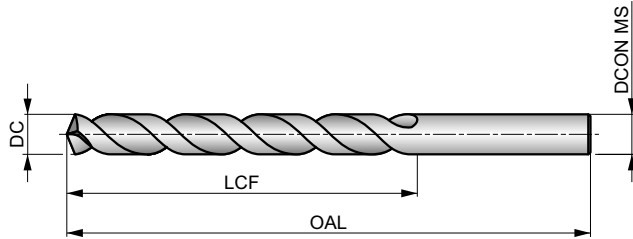

HSS-E	DIN 338	4xD
130°	Bright	
VA	R	DC h8

Adéquation du groupe de matériaux de la pièce, valeurs de départ pour la vitesse de coupe (m/min) et code Alpha d'avance. Les tableaux d'avances par tour se trouvent à partir de la page 175.

P1.1 33 I	P1.2 37 I	P1.3 38 I	P2.1 28 I	P2.2 25 G	P2.3 22 E	P3.1 19 F	P3.2 15 F	P3.3 13 E	P4.1 11 F	P4.2 10 E	P4.3 8 D	M1.1 21 E	M1.2 17 E
M2.1 18 E	M2.2 15 E	M2.3 13 B	M3.1 10 G	M3.2 9 G	M3.3 8 G	M4.1 10 D	M4.2 9 B	K1.1 30 H	K1.2 22 F	K1.3 17 F	K2.1 25 E	K2.2 20 E	K2.3 16 E
K3.1 22 E	K3.2 17 E	K3.3 13 E	K4.1 20 E	K4.2 15 E	K4.3 11 E	K4.4 10 E	K4.5 8 E	K5.1 23 E	K5.2 17 E	K5.3 13 E	N1.1 33 J	N1.2 25 J	N1.3 17 I
N2.1 42 H	N2.2 37 H	N2.3 27 H	N3.1 59 H	N3.2 35 I	N3.3 18 G	N4.1 30 J	N4.2 28 H	N4.3 14 F	S1.1 25 G	S1.2 16 E	S1.3 7 B	S2.1 9 G	S2.2 8 E
S3.1 7 G	S3.2 6 E	S4.1 5 G	S4.2 5 E										

Produit	DC	DC	DC	LCF	OAL	DCON MS
	(inch)	(mm)	(inch)	(mm)	(mm)	(mm)
A147.3	–	0.30	0.0118	3.0	19.0	0.30
A147.4	–	0.40	0.0157	5.0	20.0	0.40
A147.5	–	0.50	0.0197	6.0	22.0	0.50
A147.6	–	0.60	0.0236	7.0	24.0	0.60
A147.7	–	0.70	0.0276	9.0	28.0	0.70
A147.8	–	0.80	0.0315	10.0	30.0	0.80
A147.9	–	0.90	0.0354	11.0	32.0	0.90
A1471.0	–	1.00	0.0394	12.0	34.0	1.00
A1471.1	–	1.10	0.0433	14.0	36.0	1.10
A1471.2	–	1.20	0.0472	16.0	38.0	1.20
A1471.3	–	1.30	0.0512	16.0	38.0	1.30
A1471.4	–	1.40	0.0551	18.0	40.0	1.40
A1471.5	–	1.50	0.0591	18.0	40.0	1.50
A1471/16	1/16	1.59	0.0625	20.0	43.0	1.59
A1471.6	–	1.60	0.0630	20.0	43.0	1.60
A1471.7	–	1.70	0.0669	20.0	43.0	1.70
A1471.8	–	1.80	0.0709	22.0	46.0	1.80
A1471.9	–	1.90	0.0748	22.0	46.0	1.90
A1472.0	–	2.00	0.0787	24.0	49.0	2.00
A1472.1	–	2.10	0.0827	24.0	49.0	2.10
A1472.2	–	2.20	0.0866	27.0	53.0	2.20
A1472.3	–	2.30	0.0906	27.0	53.0	2.30
A1473/32	3/32	2.38	0.0938	30.0	57.0	2.38
A1472.4	–	2.40	0.0945	30.0	57.0	2.40

Produit	DC	DC	DC	LCF	OAL	DCON MS
	(inch)	(mm)	(inch)	(mm)	(mm)	(mm)
A1472.5	–	2.50	0.0984	30.0	57.0	2.50
A1472.6	–	2.60	0.1024	30.0	57.0	2.60
A1472.7	–	2.70	0.1063	33.0	61.0	2.70
A1472.8	–	2.80	0.1102	33.0	61.0	2.80
A1472.9	–	2.90	0.1142	33.0	61.0	2.90
A1473.0	–	3.00	0.1181	33.0	61.0	3.00
A1473.1	–	3.10	0.1220	36.0	65.0	3.10
A1471/8	1/8	3.18	0.1250	36.0	65.0	3.18
A1473.2	–	3.20	0.1260	36.0	65.0	3.20
A1473.3	–	3.30	0.1299	36.0	65.0	3.30
A1473.4	–	3.40	0.1339	39.0	70.0	3.40
A1473.5	–	3.50	0.1378	39.0	70.0	3.50
A1473.6	–	3.60	0.1417	39.0	70.0	3.60
A1473.7	–	3.70	0.1457	39.0	70.0	3.70
A1473.8	–	3.80	0.1496	43.0	75.0	3.80
A1473.9	–	3.90	0.1535	43.0	75.0	3.90
A1475/32	5/32	3.97	0.1563	43.0	75.0	3.97
A1474.0	–	4.00	0.1575	43.0	75.0	4.00
A1474.1	–	4.10	0.1614	43.0	75.0	4.10
A1474.2	–	4.20	0.1654	43.0	75.0	4.20
A1474.3	–	4.30	0.1693	47.0	80.0	4.30
A1474.4	–	4.40	0.1732	47.0	80.0	4.40
A1474.5	–	4.50	0.1772	47.0	80.0	4.50
A1474.6	–	4.60	0.1811	47.0	80.0	4.60



Produit	DC	DC	DC	LCF	OAL	DCON MS
	(inch)	(mm)	(inch)	(mm)	(mm)	(mm)
A1474.7	–	4.70	0.1850	47.0	80.0	4.70
A1473/16	3/16	4.76	0.1875	52.0	86.0	4.76
A1474.8	–	4.80	0.1890	52.0	86.0	4.80
A1474.9	–	4.90	0.1929	52.0	86.0	4.90
A1475.0	–	5.00	0.1969	52.0	86.0	5.00
A1475.1	–	5.10	0.2008	52.0	86.0	5.10
A1475.2	–	5.20	0.2047	52.0	86.0	5.20
A1475.3	–	5.30	0.2087	52.0	86.0	5.30
A1475.4	–	5.40	0.2126	57.0	93.0	5.40
A1475.5	–	5.50	0.2165	57.0	93.0	5.50
A1475.6	–	5.60	0.2205	57.0	93.0	5.60
A1475.7	–	5.70	0.2244	57.0	93.0	5.70
A1475.8	–	5.80	0.2283	57.0	93.0	5.80
A1475.9	–	5.90	0.2323	57.0	93.0	5.90
A1476.0	–	6.00	0.2362	57.0	93.0	6.00
A1476.1	–	6.10	0.2402	63.0	101.0	6.10
A1476.2	–	6.20	0.2441	63.0	101.0	6.20
A1476.3	–	6.30	0.2480	63.0	101.0	6.30
A1471/4	1/4	6.35	0.2500	63.0	101.0	6.35
A1476.4	–	6.40	0.2520	63.0	101.0	6.40
A1476.5	–	6.50	0.2559	63.0	101.0	6.50
A1476.6	–	6.60	0.2598	63.0	101.0	6.60
A1476.7	–	6.70	0.2638	63.0	101.0	6.70
A1476.8	–	6.80	0.2677	69.0	109.0	6.80
A1476.9	–	6.90	0.2717	69.0	109.0	6.90
A1477.0	–	7.00	0.2756	69.0	109.0	7.00
A1477.1	–	7.10	0.2795	69.0	109.0	7.10
A1477.2	–	7.20	0.2835	69.0	109.0	7.20
A1477.3	–	7.30	0.2874	69.0	109.0	7.30
A1477.4	–	7.40	0.2913	69.0	109.0	7.40
A1477.5	–	7.50	0.2953	69.0	109.0	7.50
A1477.6	–	7.60	0.2992	75.0	117.0	7.60
A1477.7	–	7.70	0.3031	75.0	117.0	7.70
A1477.8	–	7.80	0.3071	75.0	117.0	7.80

Produit	DC	DC	DC	LCF	OAL	DCON MS
	(inch)	(mm)	(inch)	(mm)	(mm)	(mm)
A1477.9	–	7.90	0.3110	75.0	117.0	7.90
A1478.0	–	8.00	0.3150	75.0	117.0	8.00
A1478.1	–	8.10	0.3189	75.0	117.0	8.10
A1478.2	–	8.20	0.3228	75.0	117.0	8.20
A1478.3	–	8.30	0.3268	75.0	117.0	8.30
A1478.4	–	8.40	0.3307	75.0	117.0	8.40
A1478.5	–	8.50	0.3346	75.0	117.0	8.50
A1478.6	–	8.60	0.3386	81.0	125.0	8.60
A1478.7	–	8.70	0.3425	81.0	125.0	8.70
A1478.8	–	8.80	0.3465	81.0	125.0	8.80
A1478.9	–	8.90	0.3504	81.0	125.0	8.90
A1479.0	–	9.00	0.3543	81.0	125.0	9.00
A1479.1	–	9.10	0.3583	81.0	125.0	9.10
A1479.2	–	9.20	0.3622	81.0	125.0	9.20
A1479.3	–	9.30	0.3661	81.0	125.0	9.30
A1479.4	–	9.40	0.3701	81.0	125.0	9.40
A1479.5	–	9.50	0.3740	81.0	125.0	9.50
A1479.6	–	9.60	0.3780	87.0	133.0	9.60
A1479.7	–	9.70	0.3819	87.0	133.0	9.70
A1479.8	–	9.80	0.3858	87.0	133.0	9.80
A1479.9	–	9.90	0.3898	87.0	133.0	9.90
A14710.0	–	10.00	0.3937	87.0	133.0	10.00
A14710.2	–	10.20	0.4016	87.0	133.0	10.20
A14710.5	–	10.50	0.4134	87.0	133.0	10.50
A14711.0	–	11.00	0.4331	94.0	142.0	11.00
A14711.2	–	11.20	0.4409	94.0	142.0	11.20
A14711.5	–	11.50	0.4528	94.0	142.0	11.50
A14712.0	–	12.00	0.4724	101.0	151.0	12.00
A14712.5	–	12.50	0.4921	101.0	151.0	12.50
A14713.0	–	13.00	0.5118	101.0	151.0	13.00
A14713.5	–	13.50	0.5315	108.0	160.0	13.50
A14714.0	–	14.00	0.5512	108.0	160.0	14.00
A14714.5	–	14.50	0.5709	114.0	169.0	14.50
A14715.0	–	15.00	0.5906	114.0	169.0	15.00



A777



Foret court en HSS-E (8% cobalt), finition avec traitement bronze

Foret performant produisant des trous de taille précise avec une finition de qualité dans des matériaux à haute résistance. Sa pointe avec affûtage en croix à 135° l'aide à se centrer automatiquement. La finition avec traitement bronze est une fine couche d'oxyde formée sur la surface de l'outil et indique un foret HSS-E à 8% de cobalt.

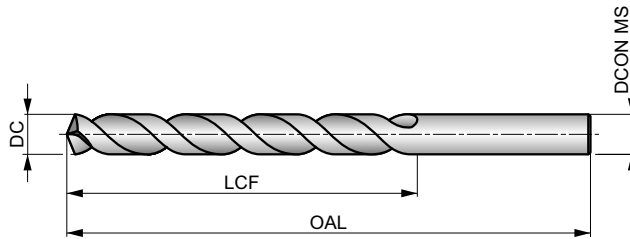

HSS-E	DIN 338	4xD
135°	Bronze	
λ 20-35°	R	DC h8

Adéquation du groupe de matériaux de la pièce, valeurs de départ pour la vitesse de coupe (m/min) et code Alpha d'avance. Les tableaux d'avances par tour se trouvent à partir de la page 175.

P1.1 ■ 36 H	P1.2 ■ 40 H	P1.3 ■ 41 H	P2.1 ■ 31 H	P2.2 ■ 27 G	P2.3 ■ 24 E	P3.1 ■ 25 F	P3.2 ■ 20 F	P3.3 ■ 17 E	P4.1 ■ 15 F	P4.2 ■ 13 E	P4.3 ■ 10 D	M1.1 ■ 30 E	M1.2 ■ 26 E
M2.1 ■ 27 E	M2.2 ■ 22 E	M3.1 ■ 13 G	M3.2 ■ 11 G	M3.3 ■ 10 G	M4.1 ■ 15 C	K1.1 ■ 35 H	K1.2 ■ 26 D	K1.3 ■ 19 D	K2.1 ■ 27 E	K2.2 ■ 22 E	K2.3 ■ 18 E	K3.1 ■ 24 E	K3.2 ■ 18 E
K3.3 ■ 15 E	K4.1 ■ 22 E	K4.2 ■ 17 E	K4.3 ■ 12 E	K4.4 ■ 11 E	K4.5 ■ 9 E	K5.1 ■ 25 E	K5.2 ■ 19 E	K5.3 ■ 15 E	N1.1 ■ 33 J	N1.2 ■ 25 J	N1.3 ■ 17 I	N2.1 ■ 46 H	N2.2 ■ 42 H
N2.3 ■ 30 H	N3.1 ■ 68 H	N3.2 ■ 40 F	N3.3 ■ 20 H	S1.1 ■ 28 F	S1.2 ■ 20 D	S1.3 ■ 11 C	S2.1 ■ 9 E	S2.2 ■ 8 B	S3.1 ■ 7 E	S3.2 ■ 6 B	S4.1 ■ 5 E	S4.2 ■ 5 B	

NAS907J. DC <= 1.4mm avec pointe 4 facettes.

Les produits de cette série sont également disponibles en coffret. Voir A295.

Produit	DC (inch)	DC (mm)	DC (inch)	LCF (mm)	OAL (mm)	DCON MS (mm)
A777.3	-	0.30	0.0118	3.0	19.0	0.30
A777.35	-	0.35	0.0138	4.0	19.0	0.35
A777.4	-	0.40	0.0157	5.0	20.0	0.40
A777.45	-	0.45	0.0177	5.0	20.0	0.45
A777.5	-	0.50	0.0197	6.0	22.0	0.50
A777.55	-	0.55	0.0217	7.0	24.0	0.55
A777.6	-	0.60	0.0236	7.0	24.0	0.60
A777.65	-	0.65	0.0256	8.0	26.0	0.65
A777.7	-	0.70	0.0276	9.0	28.0	0.70
A777.8	-	0.80	0.0315	10.0	30.0	0.80
A777.9	-	0.90	0.0354	11.0	32.0	0.90
A777.95	-	0.95	0.0374	11.0	32.0	0.95
A7771.0	-	1.00	0.0394	12.0	34.0	1.00
A7771.1	-	1.10	0.0433	14.0	36.0	1.10
A7771.2	-	1.20	0.0472	16.0	38.0	1.20
A7771.3	-	1.30	0.0512	16.0	38.0	1.30
A7771.4	-	1.40	0.0551	18.0	40.0	1.40
A7771.5	-	1.50	0.0591	18.0	40.0	1.50
A7771/16	1/16	1.59	0.0625	20.0	43.0	1.59
A7771.6	-	1.60	0.0630	20.0	43.0	1.60
A7771.7	-	1.70	0.0669	20.0	43.0	1.70
A7771.8	-	1.80	0.0709	22.0	46.0	1.80
A7771.9	-	1.90	0.0748	22.0	46.0	1.90
A7775/64	5/64	1.98	0.0781	24.0	49.0	1.98

Produit	DC (inch)	DC (mm)	DC (inch)	LCF (mm)	OAL (mm)	DCON MS (mm)
A7772.0	-	2.00	0.0787	24.0	49.0	2.00
A7772.1	-	2.10	0.0827	24.0	49.0	2.10
A7772.2	-	2.20	0.0866	27.0	53.0	2.20
A7772.3	-	2.30	0.0906	27.0	53.0	2.30
A7773/32	3/32	2.38	0.0938	30.0	57.0	2.38
A7772.4	-	2.40	0.0945	30.0	57.0	2.40
A7772.5	-	2.50	0.0984	30.0	57.0	2.50
A7772.6	-	2.60	0.1024	30.0	57.0	2.60
A7772.7	-	2.70	0.1063	33.0	61.0	2.70
A7777/64	7/64	2.78	0.1094	33.0	61.0	2.78
A7772.8	-	2.80	0.1102	33.0	61.0	2.80
A7772.9	-	2.90	0.1142	33.0	61.0	2.90
A7773.0	-	3.00	0.1181	33.0	61.0	3.00
A7773.1	-	3.10	0.1220	36.0	65.0	3.10
A7771/8	1/8	3.18	0.1250	36.0	65.0	3.18
A7773.2	-	3.20	0.1260	36.0	65.0	3.20
A7773.3	-	3.30	0.1299	36.0	65.0	3.30
A7773.4	-	3.40	0.1339	39.0	70.0	3.40
A7773.5	-	3.50	0.1378	39.0	70.0	3.50
A7779/64	9/64	3.57	0.1406	39.0	70.0	3.57
A7773.6	-	3.60	0.1417	39.0	70.0	3.60
A7773.7	-	3.70	0.1457	39.0	70.0	3.70
A7773.8	-	3.80	0.1496	43.0	75.0	3.80
A7773.9	-	3.90	0.1535	43.0	75.0	3.90



Produit	DC	DC	DC	LCF	OAL	D CON MS
	(inch)	(mm)	(inch)	(mm)	(mm)	(mm)
A7775/32	5/32	3.97	0.1563	43.0	75.0	3.97
A7774.0	–	4.00	0.1575	43.0	75.0	4.00
A7774.1	–	4.10	0.1614	43.0	75.0	4.10
A7774.2	–	4.20	0.1654	43.0	75.0	4.20
A7774.3	–	4.30	0.1693	47.0	80.0	4.30
A77711/64	11/64	4.37	0.1719	47.0	80.0	4.37
A7774.4	–	4.40	0.1732	47.0	80.0	4.40
A7774.5	–	4.50	0.1772	47.0	80.0	4.50
A7774.6	–	4.60	0.1811	47.0	80.0	4.60
A7774.7	–	4.70	0.1850	47.0	80.0	4.70
A7773/16	3/16	4.76	0.1875	52.0	86.0	4.76
A7774.8	–	4.80	0.1890	52.0	86.0	4.80
A7774.9	–	4.90	0.1929	52.0	86.0	4.90
A7775.0	–	5.00	0.1969	52.0	86.0	5.00
A7775.1	–	5.10	0.2008	52.0	86.0	5.10
A77713/64	13/64	5.16	0.2031	52.0	86.0	5.16
A7775.2	–	5.20	0.2047	52.0	86.0	5.20
A7775.3	–	5.30	0.2087	52.0	86.0	5.30
A7775.4	–	5.40	0.2126	57.0	93.0	5.40
A7775.5	–	5.50	0.2165	57.0	93.0	5.50
A7777/32	7/32	5.56	0.2188	57.0	93.0	5.56
A7775.6	–	5.60	0.2205	57.0	93.0	5.60
A7775.7	–	5.70	0.2244	57.0	93.0	5.70
A7775.8	–	5.80	0.2283	57.0	93.0	5.80
A7775.9	–	5.90	0.2323	57.0	93.0	5.90
A77715/64	15/64	5.95	0.2344	57.0	93.0	5.95
A7776.0	–	6.00	0.2362	57.0	93.0	6.00
A7776.1	–	6.10	0.2402	63.0	101.0	6.10
A7776.2	–	6.20	0.2441	63.0	101.0	6.20
A7776.3	–	6.30	0.2480	63.0	101.0	6.30
A7771/4	1/4	6.35	0.2500	63.0	101.0	6.35
A7776.4	–	6.40	0.2520	63.0	101.0	6.40
A7776.5	–	6.50	0.2559	63.0	101.0	6.50
A7776.6	–	6.60	0.2598	63.0	101.0	6.60
A7776.7	–	6.70	0.2638	63.0	101.0	6.70
A77717/64	17/64	6.75	0.2656	69.0	109.0	6.75
A7776.8	–	6.80	0.2677	69.0	109.0	6.80
A7776.9	–	6.90	0.2717	69.0	109.0	6.90
A7777.0	–	7.00	0.2756	69.0	109.0	7.00
A7777.1	–	7.10	0.2795	69.0	109.0	7.10
A7779/32	9/32	7.14	0.2813	69.0	109.0	7.14
A7777.2	–	7.20	0.2835	69.0	109.0	7.20
A7777.3	–	7.30	0.2874	69.0	109.0	7.30
A7777.4	–	7.40	0.2913	69.0	109.0	7.40
A7777.5	–	7.50	0.2953	69.0	109.0	7.50
A77719/64	19/64	7.54	0.2969	75.0	117.0	7.54
A7777.6	–	7.60	0.2992	75.0	117.0	7.60
A7777.7	–	7.70	0.3031	75.0	117.0	7.70
A7777.8	–	7.80	0.3071	75.0	117.0	7.80
A7777.9	–	7.90	0.3110	75.0	117.0	7.90
A7775/16	5/16	7.94	0.3125	75.0	117.0	7.94
A7778.0	–	8.00	0.3150	75.0	117.0	8.00

Produit	DC	DC	DC	LCF	OAL	D CON MS
	(inch)	(mm)	(inch)	(mm)	(mm)	(mm)
A7778.1	–	8.10	0.3189	75.0	117.0	8.10
A7778.2	–	8.20	0.3228	75.0	117.0	8.20
A7778.3	–	8.30	0.3268	75.0	117.0	8.30
A77721/64	21/64	8.33	0.3281	75.0	117.0	8.33
A7778.4	–	8.40	0.3307	75.0	117.0	8.40
A7778.5	–	8.50	0.3346	75.0	117.0	8.50
A7778.6	–	8.60	0.3386	81.0	125.0	8.60
A7778.7	–	8.70	0.3425	81.0	125.0	8.70
A77711/32	11/32	8.73	0.3438	81.0	125.0	8.73
A7778.8	–	8.80	0.3465	81.0	125.0	8.80
A7778.9	–	8.90	0.3504	81.0	125.0	8.90
A7779.0	–	9.00	0.3543	81.0	125.0	9.00
A7779.1	–	9.10	0.3583	81.0	125.0	9.10
A77723/64	23/64	9.13	0.3594	81.0	125.0	9.13
A7779.2	–	9.20	0.3622	81.0	125.0	9.20
A7779.3	–	9.30	0.3661	81.0	125.0	9.30
A7779.4	–	9.40	0.3701	81.0	125.0	9.40
A7779.5	–	9.50	0.3740	81.0	125.0	9.50
A7773/8	3/8	9.52	0.3750	87.0	133.0	9.52
A7779.6	–	9.60	0.3780	87.0	133.0	9.60
A7779.7	–	9.70	0.3819	87.0	133.0	9.70
A7779.8	–	9.80	0.3858	87.0	133.0	9.80
A7779.9	–	9.90	0.3898	87.0	133.0	9.90
A77725/64	25/64	9.92	0.3906	87.0	133.0	9.92
A77710.0	–	10.00	0.3937	87.0	133.0	10.00
A77710.1	–	10.10	0.3976	87.0	133.0	10.10
A77710.2	–	10.20	0.4016	87.0	133.0	10.20
A77713/32	13/32	10.32	0.4063	87.0	133.0	10.32
A77710.5	–	10.50	0.4134	87.0	133.0	10.50
A77727/64	27/64	10.72	0.4219	94.0	142.0	10.72
A77710.8	–	10.80	0.4252	94.0	142.0	10.80
A77711.0	–	11.00	0.4331	94.0	142.0	11.00
A7777/16	7/16	11.11	0.4375	94.0	142.0	11.11
A77711.2	–	11.20	0.4409	94.0	142.0	11.20
A77711.5	–	11.50	0.4528	94.0	142.0	11.50
A77729/64	29/64	11.51	0.4531	94.0	142.0	11.51
A77711.8	–	11.80	0.4646	94.0	142.0	11.80
A77715/32	15/32	11.91	0.4688	101.0	151.0	11.91
A77712.0	–	12.00	0.4724	101.0	151.0	12.00
A77712.2	–	12.20	0.4803	101.0	151.0	12.20
A77731/64	31/64	12.30	0.4844	101.0	151.0	12.30
A77712.5	–	12.50	0.4921	101.0	151.0	12.50
A7771/2	1/2	12.70	0.5000	101.0	151.0	12.70
A77712.8	–	12.80	0.5039	101.0	151.0	12.80
A77713.0	–	13.00	0.5118	101.0	151.0	13.00
A77713.5	–	13.50	0.5315	108.0	160.0	13.50
A77714.0	–	14.00	0.5512	108.0	160.0	14.00
A77714.5	–	14.50	0.5709	114.0	169.0	14.50
A77715.0	–	15.00	0.5906	114.0	169.0	15.00
A77715.5	–	15.50	0.6102	120.0	178.0	15.50
A77716.0	–	16.00	0.6299	120.0	178.0	16.00



A160



Foret court en HSS, finition avec traitement vapeur, avec pointe en carbure brasée

Foret avec un corps en HSS et une pointe en carbure brasée donnant les performances d'un foret en carbure monobloc grâce à son corps résistant et flexible. Il possède une pointe à 118° auto-centrante à 4 facettes, ce qui en fait un choix économique pour le perçage des matériaux en fonte. Il peut être utilisé sur des machines conventionnelles et CNC.

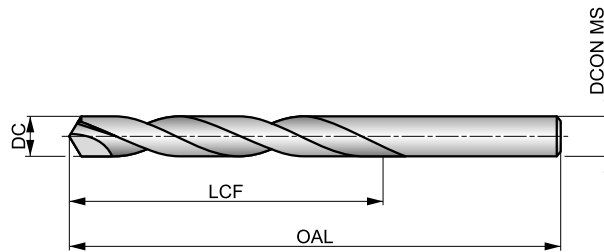

HSS HM	DIN 338	4xD
118°	Bright ST	
λ 20-35°	R	DC h8

Adéquation du groupe de matériaux de la pièce, valeurs de départ pour la vitesse de coupe (m/min) et code Alpha d'avance. Les tableaux d'avances par tour se trouvent à partir de la page 175.

P1.1 ▣73 E	P1.2 ▣82 E	P1.3 ▣85 E	P2.1 ▣63 E	P2.2 ▣55 D	P2.3 ▣49 C	P3.1 ▣59 D	P3.2 ▣47 D	P3.3 ▣40 C	P4.1 ▣35 D	P4.2 ▣30 C	P4.3 ▣24 A	M1.1 ▣55 B	M1.2 ▣46 B
M2.1 ▣49 B	M2.2 ▣40 B	M3.1 ▣41 C	M3.2 ▣35 C	M3.3 ▣32 C	M4.1 ▣35 A	K1.1 ▣50 C	K1.2 ▣37 A	K1.3 ▣28 A	K2.1 ▣43 A	K2.2 ▣35 A	K2.3 ▣28 A	K3.1 ▣38 A	K3.2 ▣29 A
K3.3 ▣24 A	K4.1 ▣35 A	K4.2 ▣27 A	K4.3 ▣20 A	K4.4 ▣17 A	K4.5 ▣14 A	K5.1 ▣40 A	K5.2 ▣30 A	K5.3 ▣23 A	N1.1 ▣50 I	N1.2 ▣38 I	N1.3 ▣25 H	N2.1 ▣62 G	N2.2 ▣55 G
N2.3 ▣40 G	N3.1 ▣119 C	N3.2 ▣70 G	N3.3 ▣35 D	N4.2 ▣60 E	S1.1 ▣35 A	S1.2 ▣35 A	S1.3 ▣25 A	S2.1 ▣33 A	S2.2 ▣28 A	S3.1 ▣25 A	S3.2 ▣20 A	S4.1 ▣20 A	S4.2 ▣16 A

Produit	DC	DC	LCF	OAL	DCON MS
	(mm)	(inch)			
A1604.0	4.00	0.1575	43.0	75.0	4.00
A1604.5	4.50	0.1772	47.0	80.0	4.50
A1605.0	5.00	0.1969	52.0	86.0	5.00
A1605.5	5.50	0.2165	57.0	93.0	5.50
A1606.0	6.00	0.2362	57.0	93.0	6.00
A1606.5	6.50	0.2559	63.0	101.0	6.50
A1606.8	6.80	0.2677	69.0	109.0	6.80
A1607.0	7.00	0.2756	69.0	109.0	7.00
A1607.5	7.50	0.2953	69.0	109.0	7.50
A1608.0	8.00	0.3150	75.0	117.0	8.00
A1608.5	8.50	0.3346	75.0	117.0	8.50
A1609.0	9.00	0.3543	81.0	125.0	9.00
A1609.5	9.50	0.3740	81.0	125.0	9.50
A16010.0	10.00	0.3937	87.0	133.0	10.00
A16010.2	10.20	0.4016	87.0	133.0	10.20
A16010.5	10.50	0.4134	87.0	133.0	10.50
A16011.0	11.00	0.4331	94.0	142.0	11.00
A16011.5	11.50	0.4528	94.0	142.0	11.50
A16012.0	12.00	0.4724	101.0	151.0	12.00
A16013.0	13.00	0.5118	101.0	151.0	13.00
A16014.0	14.00	0.5512	108.0	160.0	14.00
A16015.0	15.00	0.5906	114.0	169.0	15.00
A16016.0	16.00	0.6299	120.0	178.0	16.00



A510



Foret court ADX en HSS, revêtement TiN

Foret haute performance capable de produire des trous de haute qualité et précis à des vitesses et des avances élevées (tolérance de trou H9). Sa pointe amincie à 130° facilite l'auto-centrage. Ce foret doit être utilisé sur des machines CNC uniquement. Le revêtement TiN améliore les performances et prolonge la durée de vie de l'outil. Convient pour le perçage de nombreux matériaux.



ADX

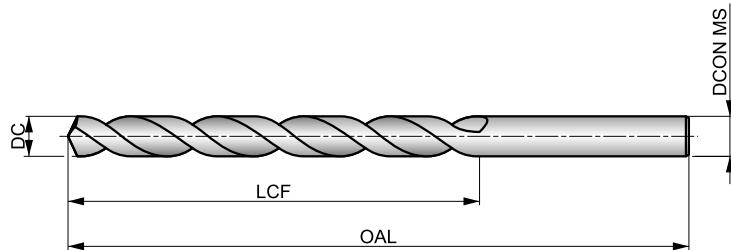

HSS	DIN 338	4xD
130°	TiN	
λ 32-40°	R	DC h8

Adéquation du groupe de matériaux de la pièce, valeurs de départ pour la vitesse de coupe (m/min) et code Alpha d'avance. Les tableaux d'avances par tour se trouvent à partir de la page 175.

P1.1 ■ 53 M	P1.2 ■ 59 M	P1.3 ■ 61 M	P2.1 ■ 45 M	P2.2 ■ 40 K	P2.3 ■ 35 F	P3.1 ■ 31 H	P3.2 ■ 25 H	P3.3 ■ 21 F	P4.1 ■ 19 H	P4.2 ■ 16 F	P4.3 ■ 13 D	M1.1 ■ 38 G	M1.2 ■ 32 G
M2.1 ■ 34 G	M2.2 ■ 28 G	M3.1 ■ 16 I	M3.2 ■ 14 I	M3.3 ■ 13 I	M4.1 ■ 19 G	K1.1 ■ 42 K	K1.2 ■ 31 J	K1.3 ■ 23 J	K2.1 ■ 34 J	K2.2 ■ 28 J	K2.3 ■ 22 F	K3.1 ■ 30 J	K3.2 ■ 23 J
K3.3 ■ 19 F	K4.1 ■ 28 J	K4.2 ■ 21 J	K4.3 ■ 16 F	K4.4 ■ 13 F	K4.5 ■ 11 F	K5.1 ■ 32 J	K5.2 ■ 24 J	K5.3 ■ 19 F	N1.1 ■ 50 G	N1.2 ■ 38 G	N1.3 ■ 25 M	N2.1 ■ 48 I	N2.2 ■ 43 I
N2.3 ■ 31 I	N3.1 ■ 85 I	N3.2 ■ 50 I	N3.3 ■ 25 D	N4.1 ■ 65 G	N4.2 ■ 50 G	N4.3 ■ 35 F	S1.1 ■ 32 G	S1.2 ■ 20 H	S1.3 ■ 4 B	S2.1 ■ 12 E	S2.2 ■ 8 E	S3.1 ■ 9 E	S3.2 ■ 6 E
S4.1 ■ 7 E	S4.2 ■ 5 E												

Produit	DC	DC	DC	LCF	OAL	DCON MS
	(inch)	(mm)	(inch)	(mm)	(mm)	(mm)
A5103.0	–	3.00	0.1181	33.0	61.0	3.00
A5103.1	–	3.10	0.1220	36.0	65.0	3.10
A5101/8	1/8	3.18	0.1250	36.0	65.0	3.18
A5103.2	–	3.20	0.1260	36.0	65.0	3.20
A5103.3	–	3.30	0.1299	36.0	65.0	3.30
A5103.4	–	3.40	0.1339	39.0	70.0	3.40
A5103.5	–	3.50	0.1378	39.0	70.0	3.50
A5109/64	9/64	3.57	0.1406	39.0	70.0	3.57
A5103.6	–	3.60	0.1417	39.0	70.0	3.60
A5103.7	–	3.70	0.1457	39.0	70.0	3.70
A5103.8	–	3.80	0.1496	43.0	75.0	3.80
A5103.9	–	3.90	0.1535	43.0	75.0	3.90
A5105/32	5/32	3.97	0.1563	43.0	75.0	3.97
A5104.0	–	4.00	0.1575	43.0	75.0	4.00
A5104.1	–	4.10	0.1614	43.0	75.0	4.10
A5104.2	–	4.20	0.1654	43.0	75.0	4.20
A5104.3	–	4.30	0.1693	47.0	80.0	4.30
A51011/64	11/64	4.37	0.1719	47.0	80.0	4.37
A5104.4	–	4.40	0.1732	47.0	80.0	4.40
A5104.5	–	4.50	0.1772	47.0	80.0	4.50
A5104.6	–	4.60	0.1811	47.0	80.0	4.60
A5104.7	–	4.70	0.1850	47.0	80.0	4.70
A5103/16	3/16	4.76	0.1875	52.0	86.0	4.76
A5104.8	–	4.80	0.1890	52.0	86.0	4.80

Produit	DC	DC	DC	LCF	OAL	DCON MS
	(inch)	(mm)	(inch)	(mm)	(mm)	(mm)
A5104.9	–	4.90	0.1929	52.0	86.0	4.90
A5105.0	–	5.00	0.1969	52.0	86.0	5.00
A5105.1	–	5.10	0.2008	52.0	86.0	5.10
A51013/64	13/64	5.16	0.2031	52.0	86.0	5.16
A5105.2	–	5.20	0.2047	52.0	86.0	5.20
A5105.3	–	5.30	0.2087	52.0	86.0	5.30
A5105.4	–	5.40	0.2126	57.0	93.0	5.40
A5105.5	–	5.50	0.2165	57.0	93.0	5.50
A5107/32	7/32	5.56	0.2188	57.0	93.0	5.56
A5105.6	–	5.60	0.2205	57.0	93.0	5.60
A5105.7	–	5.70	0.2244	57.0	93.0	5.70
A5105.8	–	5.80	0.2283	57.0	93.0	5.80
A5105.9	–	5.90	0.2323	57.0	93.0	5.90
A51015/64	15/64	5.95	0.2344	57.0	93.0	5.95
A5106.0	–	6.00	0.2362	57.0	93.0	6.00
A5106.1	–	6.10	0.2402	63.0	101.0	6.10
A5106.2	–	6.20	0.2441	63.0	101.0	6.20
A5106.3	–	6.30	0.2480	63.0	101.0	6.30
A5101/4	1/4	6.35	0.2500	63.0	101.0	6.35
A5106.4	–	6.40	0.2520	63.0	101.0	6.40
A5106.5	–	6.50	0.2559	63.0	101.0	6.50
A5106.6	–	6.60	0.2598	63.0	101.0	6.60
A5106.7	–	6.70	0.2638	63.0	101.0	6.70
A51017/64	17/64	6.75	0.2656	69.0	109.0	6.75



Produit	DC	DC	DC	LCF	OAL	D CON MS
	(inch)	(mm)	(inch)	(mm)	(mm)	(mm)
A5106.8	—	6.80	0.2677	69.0	109.0	6.80
A5106.9	—	6.90	0.2717	69.0	109.0	6.90
A5107.0	—	7.00	0.2756	69.0	109.0	7.00
A5107.1	—	7.10	0.2795	69.0	109.0	7.10
A5109/32	9/32	7.14	0.2813	69.0	109.0	7.14
A5107.2	—	7.20	0.2835	69.0	109.0	7.20
A5107.3	—	7.30	0.2874	69.0	109.0	7.30
A5107.4	—	7.40	0.2913	69.0	109.0	7.40
A5107.5	—	7.50	0.2953	69.0	109.0	7.50
A51019/64	19/64	7.54	0.2969	75.0	117.0	7.54
A5107.6	—	7.60	0.2992	75.0	117.0	7.60
A5107.7	—	7.70	0.3031	75.0	117.0	7.70
A5107.8	—	7.80	0.3071	75.0	117.0	7.80
A5107.9	—	7.90	0.3110	75.0	117.0	7.90
A5105/16	5/16	7.94	0.3125	75.0	117.0	7.94
A5108.0	—	8.00	0.3150	75.0	117.0	8.00
A5108.1	—	8.10	0.3189	75.0	117.0	8.10
A5108.2	—	8.20	0.3228	75.0	117.0	8.20
A5108.3	—	8.30	0.3268	75.0	117.0	8.30
A51021/64	21/64	8.33	0.3281	75.0	117.0	8.33
A5108.4	—	8.40	0.3307	75.0	117.0	8.40
A5108.5	—	8.50	0.3346	75.0	117.0	8.50
A5108.6	—	8.60	0.3386	81.0	125.0	8.60
A5108.7	—	8.70	0.3425	81.0	125.0	8.70
A51011/32	11/32	8.73	0.3438	81.0	125.0	8.73
A5108.8	—	8.80	0.3465	81.0	125.0	8.80
A5108.9	—	8.90	0.3504	81.0	125.0	8.90
A5109.0	—	9.00	0.3543	81.0	125.0	9.00
A5109.1	—	9.10	0.3583	81.0	125.0	9.10
A51023/64	23/64	9.13	0.3594	81.0	125.0	9.13
A5109.2	—	9.20	0.3622	81.0	125.0	9.20
A5109.3	—	9.30	0.3661	81.0	125.0	9.30
A5109.4	—	9.40	0.3701	81.0	125.0	9.40
A5109.5	—	9.50	0.3740	81.0	125.0	9.50
A5103/8	3/8	9.52	0.3750	87.0	133.0	9.52
A5109.6	—	9.60	0.3780	87.0	133.0	9.60
A5109.7	—	9.70	0.3819	87.0	133.0	9.70
A5109.8	—	9.80	0.3858	87.0	133.0	9.80
A5109.9	—	9.90	0.3898	87.0	133.0	9.90
A51025/64	25/64	9.92	0.3906	87.0	133.0	9.92

Produit	DC	DC	DC	LCF	OAL	D CON MS
	(inch)	(mm)	(inch)	(mm)	(mm)	(mm)
A51010.0	—	10.00	0.3937	87.0	133.0	10.00
A51010.1	—	10.10	0.3976	87.0	133.0	10.10
A51010.2	—	10.20	0.4016	87.0	133.0	10.20
A51010.3	—	10.30	0.4055	87.0	133.0	10.30
A51013/32	13/32	10.32	0.4063	87.0	133.0	10.32
A51010.4	—	10.40	0.4094	87.0	133.0	10.40
A51010.5	—	10.50	0.4134	87.0	133.0	10.50
A51010.6	—	10.60	0.4173	87.0	133.0	10.60
A51010.7	—	10.70	0.4213	94.0	142.0	10.70
A51027/64	27/64	10.72	0.4219	94.0	142.0	10.72
A51010.8	—	10.80	0.4252	94.0	142.0	10.80
A51010.9	—	10.90	0.4291	94.0	142.0	10.90
A51011.0	—	11.00	0.4331	94.0	142.0	11.00
A51011.1	—	11.10	0.4370	94.0	142.0	11.10
A5107/16	7/16	11.11	0.4375	94.0	142.0	11.11
A51011.2	—	11.20	0.4409	94.0	142.0	11.20
A51011.3	—	11.30	0.4449	94.0	142.0	11.30
A51011.4	—	11.40	0.4488	94.0	142.0	11.40
A51011.5	—	11.50	0.4528	94.0	142.0	11.50
A51029/64	29/64	11.51	0.4531	94.0	142.0	11.51
A51011.6	—	11.60	0.4567	94.0	142.0	11.60
A51011.7	—	11.70	0.4606	94.0	142.0	11.70
A51011.8	—	11.80	0.4646	94.0	142.0	11.80
A51011.9	—	11.90	0.4685	101.0	151.0	11.90
A51015/32	15/32	11.91	0.4688	101.0	151.0	11.91
A51012.0	—	12.00	0.4724	101.0	151.0	12.00
A51012.1	—	12.10	0.4764	101.0	151.0	12.10
A51012.2	—	12.20	0.4803	101.0	151.0	12.20
A51012.3	—	12.30	0.4843	101.0	151.0	12.30
A51031/64	31/64	12.30	0.4844	101.0	151.0	12.30
A51012.4	—	12.40	0.4882	101.0	151.0	12.40
A51012.5	—	12.50	0.4921	101.0	151.0	12.50
A51012.6	—	12.60	0.4961	101.0	151.0	12.60
A51012.7	—	12.70	0.5000	101.0	151.0	12.70
A5101/2	1/2	12.70	0.5000	101.0	151.0	12.70
A51012.8	—	12.80	0.5039	101.0	151.0	12.80
A51012.9	—	12.90	0.5079	101.0	151.0	12.90
A51013.0	—	13.00	0.5118	101.0	151.0	13.00
A51014.0	—	14.00	0.5512	108.0	160.0	14.00



A553



Foret court ADX en HSS-E (5% Cobalt), revêtement TiAlN avec arrosage centralisé

Foret haute performance capable de produire des trous de haute qualité et précis à des vitesses et des avances élevées (tolérance de trou H9). Sa pointe amincie à 130° et le revêtement TiAlN Top améliorent les performances et prolongent la durée de vie de l'outil. Ce foret ne doit être utilisé que sur des machines CNC. Convient pour le perçage de nombreux matériaux.

ADX

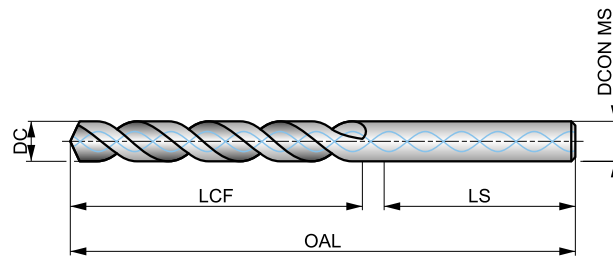

HSS-E	DORMER	5xD
130°	TiAlN Top	DIN 6535HA
$\lambda > 35^\circ$	R	
DC h8		

Adéquation du groupe de matériaux de la pièce, valeurs de départ pour la vitesse de coupe (m/min) et code Alpha d'avance. Les tableaux d'avances par tour se trouvent à partir de la page 175.

P1.1 ■ 80 L	P1.2 ■ 89 L	P1.3 ■ 92 L	P2.1 ■ 68 L	P2.2 ■ 60 L	P2.3 ■ 53 F	P3.1 ■ 41 H	P3.2 ■ 33 H	P3.3 ■ 28 F	P4.1 ■ 25 H	P4.2 ■ 21 F	P4.3 ■ 17 D	M1.1 ■ 55 G	M1.2 ■ 46 G
M2.1 ■ 49 G	M2.2 ■ 40 G	M3.1 ■ 22 I	M3.2 ■ 19 I	M3.3 ■ 17 I	M4.1 ■ 27 G	K1.1 ■ 70 K	K1.2 ■ 52 J	K1.3 ■ 39 J	K2.1 ■ 55 J	K2.2 ■ 45 J	K2.3 ■ 36 F	K3.1 ■ 49 J	K3.2 ■ 37 J
K3.3 ■ 30 F	K4.1 ■ 45 J	K4.2 ■ 34 J	K4.3 ■ 25 F	K4.4 ■ 22 F	K4.5 ■ 18 F	K5.1 ■ 51 J	K5.2 ■ 39 J	K5.3 ■ 30 F	N1.1 ■ 70 H	N1.2 ■ 53 H	N1.3 ■ 35 M	N2.1 ■ 85 I	N2.2 ■ 76 I
N2.3 ■ 55 I	N3.1 ■ 144 I	N3.2 ■ 85 I	N3.3 ■ 43 G	N4.1 ■ 90 G	S1.1 ■ 45 G	S1.2 ■ 30 E	S1.3 ■ 8 C	S2.1 ■ 20 E	S2.2 ■ 14 G	S3.1 ■ 15 E	S3.2 ■ 10 G	S4.1 ■ 12 E	S4.2 ■ 8 G

DCON MS tolérance h6.

Produit	DC	DC	LCF	OAL	LS	DCON MS	Produit	DC	DC	LCF	OAL	LS	DCON MS
	(mm)	(inch)						(mm)	(mm)				
A5535.0	5.00	0.1969	36.0	79.0	36.0	6.00	A55311.3	11.30	0.4449	94.0	150.0	45.0	12.00
A5535.2	5.20	0.2047	38.0	79.0	36.0	6.00	A55311.5	11.50	0.4528	94.0	150.0	45.0	12.00
A5535.5	5.50	0.2165	40.0	79.0	36.0	6.00	A55312.0	12.00	0.4724	94.0	150.0	45.0	12.00
A5536.0	6.00	0.2362	43.0	79.0	36.0	6.00	A55312.5	12.50	0.4921	101.0	160.0	45.0	14.00
A5536.3	6.30	0.2480	46.0	87.0	36.0	8.00	A55313.0	13.00	0.5118	101.0	160.0	45.0	14.00
A5536.5	6.50	0.2559	47.0	87.0	36.0	8.00	A55313.5	13.50	0.5315	101.0	160.0	45.0	14.00
A5536.8	6.80	0.2677	48.0	87.0	36.0	8.00	A55314.0	14.00	0.5512	101.0	160.0	45.0	14.00
A5536.9	6.90	0.2717	48.0	87.0	36.0	8.00	A55314.25	14.25	0.5610	108.0	170.0	48.0	16.00
A5537.0	7.00	0.2756	48.0	87.0	36.0	8.00	A55314.5	14.50	0.5709	108.0	170.0	48.0	16.00
A5537.4	7.40	0.2913	54.0	94.0	36.0	8.00	A55315.0	15.00	0.5906	108.0	170.0	48.0	16.00
A5537.5	7.50	0.2953	54.0	94.0	36.0	8.00	A55315.25	15.25	0.6004	108.0	170.0	48.0	16.00
A5538.0	8.00	0.3150	58.0	94.0	36.0	8.00	A55315.5	15.50	0.6102	108.0	170.0	48.0	16.00
A5538.5	8.50	0.3346	75.0	130.0	40.0	10.00	A55316.0	16.00	0.6299	108.0	170.0	48.0	16.00
A5538.7	8.70	0.3425	75.0	130.0	40.0	10.00	A55316.5	16.50	0.6496	125.0	190.0	48.0	18.00
A5539.0	9.00	0.3543	75.0	130.0	40.0	10.00	A55317.0	17.00	0.6693	125.0	190.0	48.0	18.00
A5539.5	9.50	0.3740	75.0	130.0	40.0	10.00	A55317.5	17.50	0.6890	130.0	190.0	48.0	18.00
A55310.0	10.00	0.3937	75.0	130.0	40.0	10.00	A55317.75	17.75	0.6988	130.0	190.0	48.0	18.00
A55310.2	10.20	0.4016	87.0	150.0	45.0	12.00	A55318.0	18.00	0.7087	130.0	190.0	48.0	18.00
A55310.3	10.30	0.4055	87.0	150.0	45.0	12.00	A55319.0	19.00	0.7480	135.0	200.0	50.0	20.00
A55310.5	10.50	0.4134	87.0	150.0	45.0	12.00	A55319.25	19.25	0.7579	140.0	200.0	50.0	20.00
A55311.0	11.00	0.4331	94.0	150.0	45.0	12.00	A55320.0	20.00	0.7874	140.0	200.0	50.0	20.00



A900



Foret court PFX en HSS-E (5% cobalt), finition brillante

Foret haute performance capable de produire des trous de haute qualité et précis à des vitesses et des avances élevées (tolérance de trou H10). Sa pointe auto-centrante à 130° et la conception spéciale de sa goujure parabolique permettent de percer des trous profonds en une seule passe. Convient à de nombreux matériaux.

PFX

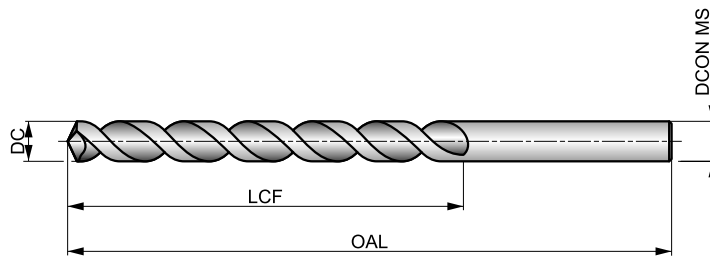

HSS-E	DIN ANSI	6×D
130°	Bright	
λ>35°	R	DC h8

Adéquation du groupe de matériaux de la pièce, valeurs de départ pour la vitesse de coupe (m/min) et code Alpha d'avance. Les tableaux d'avances par tour se trouvent à partir de la page 175.

P1.1 ■ 34 H	P1.2 ■ 39 H	P1.3 ■ 40 H	P2.1 ■ 30 H	P2.2 ■ 26 H	P2.3 ■ 23 E	P3.1 ■ 31 H	P3.2 ■ 25 H	P3.3 ■ 21 E	P4.1 ■ 19 H	P4.2 ■ 16 E	P4.3 ■ 13 E	M1.1 ■ 21 E	M1.2 ■ 17 E
M2.1 ■ 18 E	M2.2 ■ 15 E	M3.1 ■ 8 E	M3.2 ■ 7 E	M3.3 ■ 6 E	M4.1 ■ 9 C	K1.1 ■ 24 J	K1.2 ■ 18 J	K1.3 ■ 13 J	K2.1 ■ 23 J	K2.2 ■ 19 J	K2.3 ■ 15 I	K3.1 ■ 21 J	K3.2 ■ 16 J
K3.3 ■ 13 I	K4.1 ■ 19 J	K4.2 ■ 14 J	K4.3 ■ 11 I	K4.4 ■ 9 I	K4.5 ■ 8 I	K5.1 ■ 22 J	K5.2 ■ 16 J	K5.3 ■ 13 I	N1.1 ■ 60 J	N1.2 ■ 45 J	N1.3 ■ 30 N	N2.1 ■ 62 N	N2.2 ■ 55 N
N2.3 ■ 40 N	N3.1 ■ 90 H	N3.2 ■ 53 I	N3.3 ■ 27 G	N4.1 ■ 55 I	N4.2 ■ 40 G	S1.1 ■ 22 E	S1.2 ■ 15 E	S1.3 ■ 6 C	S2.1 ■ 9 G	S2.2 ■ 8 C	S3.1 ■ 7 G	S3.2 ■ 6 C	S4.1 ■ 5 G
S4.2 ■ 5 C													

Produit	DC	DC	DC	LCF	OAL	DCON MS
	(inch)	(mm)	(inch)	(mm)	(mm)	(mm)
A9001.0	–	1.00	0.0394	12.0	34.0	1.00
A9001.1	–	1.10	0.0433	14.0	36.0	1.10
A9003/64	3/64	1.19	0.0469	19.0	44.0	1.19
A9001.2	–	1.20	0.0472	16.0	38.0	1.20
A9001.25	–	1.25	0.0492	16.0	36.0	1.25
A9001.3	–	1.30	0.0512	16.0	38.0	1.30
A9001.4	–	1.40	0.0551	18.0	40.0	1.40
A9001.5	–	1.50	0.0591	18.0	40.0	1.50
A9001.55	–	1.55	0.0610	20.0	43.0	1.55
A9001/16	1/16	1.59	0.0625	22.0	48.0	1.59
A9001.6	–	1.60	0.0630	20.0	43.0	1.60
A9001.7	–	1.70	0.0669	20.0	43.0	1.70
A9001.75	–	1.75	0.0689	22.0	46.0	1.75
A9001.8	–	1.80	0.0709	22.0	46.0	1.80
A9001.9	–	1.90	0.0748	22.0	46.0	1.90
A9005/64	5/64	1.98	0.0781	25.0	51.0	1.98
A9002.0	–	2.00	0.0787	24.0	49.0	2.00
A9002.1	–	2.10	0.0827	24.0	49.0	2.10
A9002.15	–	2.15	0.0846	27.0	53.0	2.15
A9002.2	–	2.20	0.0866	27.0	53.0	2.20
A9002.3	–	2.30	0.0906	27.0	53.0	2.30
A9003/32	3/32	2.38	0.0937	32.0	57.0	2.38
A9002.4	–	2.40	0.0945	30.0	57.0	2.40
A9002.5	–	2.50	0.0984	30.0	57.0	2.50

Produit	DC	DC	DC	LCF	OAL	DCON MS
	(inch)	(mm)	(inch)	(mm)	(mm)	(mm)
A9002.6	–	2.60	0.1024	30.0	57.0	2.60
A9002.7	–	2.70	0.1063	33.0	61.0	2.70
A9007/64	7/64	2.78	0.1094	38.0	67.0	2.78
A9002.8	–	2.80	0.1102	33.0	61.0	2.80
A9002.9	–	2.90	0.1142	33.0	61.0	2.90
A9003.0	–	3.00	0.1181	33.0	61.0	3.00
A9003.1	–	3.10	0.1220	36.0	65.0	3.10
A9001/8	1/8	3.18	0.1250	41.0	70.0	3.18
A9003.2	–	3.20	0.1260	36.0	65.0	3.20
A9003.3	–	3.30	0.1299	36.0	65.0	3.30
A9003.4	–	3.40	0.1339	39.0	70.0	3.40
A9003.5	–	3.50	0.1378	39.0	70.0	3.50
A9009/64	9/64	3.57	0.1406	44.0	73.0	3.57
A9003.6	–	3.60	0.1417	39.0	70.0	3.60
A9003.7	–	3.70	0.1457	39.0	70.0	3.70
A9003.8	–	3.80	0.1496	43.0	75.0	3.80
A9003.9	–	3.90	0.1535	43.0	75.0	3.90
A9005/32	5/32	3.97	0.1563	51.0	79.0	3.97
A9004.0	–	4.00	0.1575	43.0	75.0	4.00
A9004.1	–	4.10	0.1614	43.0	75.0	4.10
A9004.2	–	4.20	0.1654	43.0	75.0	4.20
A9004.3	–	4.30	0.1693	47.0	80.0	4.30
A90011/64	11/64	4.37	0.1719	54.0	83.0	4.37
A9004.4	–	4.40	0.1732	47.0	80.0	4.40



A901



Foret court PFX en HSS-E (5% Cobalt), revêtement Alcrona

Foret haute performance capable de produire des trous de haute qualité et précis à des vitesses et des avances élevées (tolérance de trou H10). Il possède une pointe à 130° et une conception spéciale de goujure parabolique. Convient à de nombreux matériaux. Le revêtement Alcrona-TOP améliore les performances et prolonge la durée de vie de l'outil.

PFX

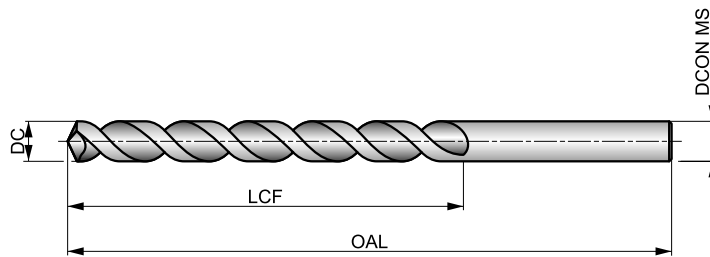

HSS-E	DIN ANSI	6xD
130°	Alcrona Top	
λ > 35°	R	DC h8

Adéquation du groupe de matériaux de la pièce, valeurs de départ pour la vitesse de coupe (m/min) et code Alpha d'avance. Les tableaux d'avances par tour se trouvent à partir de la page 175.

P1.1 ■ 58 J	P1.2 ■ 65 J	P1.3 ■ 68 J	P2.1 ■ 50 J	P2.2 ■ 44 I	P2.3 ■ 39 G	P3.1 ■ 49 I	P3.2 ■ 39 I	P3.3 ■ 33 G	P4.1 ■ 29 I	P4.2 ■ 25 G	P4.3 ■ 20 G	M1.1 ■ 23 E	M1.2 ■ 20 E
M2.1 ■ 21 E	M2.2 ■ 17 E	M3.1 ■ 10 E	M3.2 ■ 9 E	M3.3 ■ 8 E	M4.1 ■ 11 C	K1.1 ■ 58 I	K1.2 ■ 43 I	K1.3 ■ 32 I	K2.1 ■ 42 J	K2.2 ■ 34 J	K2.3 ■ 27 I	K3.1 ■ 37 J	K3.2 ■ 28 J
K3.3 ■ 23 I	K4.1 ■ 34 J	K4.2 ■ 26 J	K4.3 ■ 19 I	K4.4 ■ 16 I	K4.5 ■ 14 I	K5.1 ■ 39 J	K5.2 ■ 29 J	K5.3 ■ 23 I	S1.1 ■ 35 G	S1.2 ■ 24 G	S1.3 ■ 10 E	S2.1 ■ 15 I	S2.2 ■ 14 E
S3.1 ■ 11 I	S3.2 ■ 10 E	S4.1 ■ 9 I	S4.2 ■ 8 E										

Produit	DC	DC	DC	LCF	OAL	DCON MS
	(inch)	(mm)	(inch)	(mm)	(mm)	(mm)
A9011.5	—	1.50	0.0591	18.0	40.0	1.50
A9011.55	—	1.55	0.0610	20.0	43.0	1.55
A9011/16	1/16	1.59	0.0625	22.0	48.0	1.59
A9011.6	—	1.60	0.0630	20.0	43.0	1.60
A9011.75	—	1.75	0.0689	22.0	46.0	1.75
A9011.8	—	1.80	0.0709	22.0	46.0	1.80
A9011.9	—	1.90	0.0748	22.0	46.0	1.90
A9015/64	5/64	1.98	0.0781	25.0	51.0	1.98
A9012.0	—	2.00	0.0787	24.0	49.0	2.00
A9012.1	—	2.10	0.0827	24.0	49.0	2.10
A9012.15	—	2.15	0.0846	27.0	53.0	2.15
A9013/32	3/32	2.38	0.0937	32.0	57.0	2.38
A9012.4	—	2.40	0.0945	30.0	57.0	2.40
A9012.5	—	2.50	0.0984	30.0	57.0	2.50
A9012.6	—	2.60	0.1024	30.0	57.0	2.60
A9012.7	—	2.70	0.1063	33.0	61.0	2.70
A9017/64	7/64	2.78	0.1094	38.0	67.0	2.78
A9012.9	—	2.90	0.1142	33.0	61.0	2.90
A9013.0	—	3.00	0.1181	33.0	61.0	3.00
A9013.1	—	3.10	0.1220	36.0	65.0	3.10
A9011/8	1/8	3.18	0.1250	41.0	70.0	3.18
A9013.2	—	3.20	0.1260	36.0	65.0	3.20
A9013.3	—	3.30	0.1299	36.0	65.0	3.30
A9013.4	—	3.40	0.1339	39.0	70.0	3.40
A9013.5	—	3.50	0.1378	39.0	70.0	3.50
A9013.6	—	3.60	0.1417	39.0	70.0	3.60

Produit	DC	DC	DC	LCF	OAL	DCON MS
	(inch)	(mm)	(inch)	(mm)	(mm)	(mm)
A9019/64	9/64	3.57	0.1406	44.0	73.0	3.57
A9013.7	—	3.70	0.1457	39.0	70.0	3.70
A9013.8	—	3.80	0.1496	43.0	75.0	3.80
A9013.9	—	3.90	0.1535	43.0	75.0	3.90
A9015/32	5/32	3.97	0.1563	51.0	79.0	3.97
A9014.0	—	4.00	0.1575	43.0	75.0	4.00
A9014.1	—	4.10	0.1614	43.0	75.0	4.10
A9014.2	—	4.20	0.1654	43.0	75.0	4.20
A9014.3	—	4.30	0.1693	47.0	80.0	4.30
A90111/64	11/64	4.37	0.1719	54.0	83.0	4.37
A9014.4	—	4.40	0.1732	47.0	80.0	4.40
A9014.5	—	4.50	0.1772	47.0	80.0	4.50
A9014.6	—	4.60	0.1811	47.0	80.0	4.60
A9014.7	—	4.70	0.1850	47.0	80.0	4.70
A9013/16	3/16	4.76	0.1875	59.0	89.0	4.76
A9014.8	—	4.80	0.1890	52.0	86.0	4.80
A9014.9	—	4.90	0.1929	52.0	86.0	4.90
A9015.0	—	5.00	0.1969	52.0	86.0	5.00
A9015.1	—	5.10	0.2008	52.0	86.0	5.10
A90113/64	13/64	5.16	0.2031	62.0	92.0	5.16
A9015.2	—	5.20	0.2047	52.0	86.0	5.20
A9015.3	—	5.30	0.2087	52.0	86.0	5.30
A9015.4	—	5.40	0.2126	57.0	93.0	5.40
A9015.5	—	5.50	0.2165	57.0	93.0	5.50
A9017/32	7/32	5.56	0.2188	64.0	95.0	5.56
A9015.6	—	5.60	0.2205	57.0	93.0	5.60



Produit	DC	DC	DC	LCF	OAL	DCON MS
	(inch)	(mm)	(inch)	(mm)	(mm)	(mm)
A9015.7	–	5.70	0.2244	57.0	93.0	5.70
A9015.8	–	5.80	0.2283	57.0	93.0	5.80
A9015.9	–	5.90	0.2323	57.0	93.0	5.90
A90115/64	15/64	5.95	0.2344	67.0	98.0	5.95
A9016.0	–	6.00	0.2362	57.0	93.0	6.00
A9016.1	–	6.10	0.2402	63.0	101.0	6.10
A9016.2	–	6.20	0.2441	63.0	101.0	6.20
A9016.3	–	6.30	0.2480	63.0	101.0	6.30
A9011/4	1/4	6.35	0.2500	70.0	102.0	6.35
A9016.4	–	6.40	0.2520	63.0	101.0	6.40
A9016.5	–	6.50	0.2559	63.0	101.0	6.50
A9016.6	–	6.60	0.2598	63.0	101.0	6.60
A9016.7	–	6.70	0.2638	63.0	101.0	6.70
A90117/64	17/64	6.75	0.2656	73.0	105.0	6.75
A9016.8	–	6.80	0.2677	69.0	109.0	6.80
A9016.9	–	6.90	0.2717	69.0	109.0	6.90
A9017.0	–	7.00	0.2756	69.0	109.0	7.00
A9017.1	–	7.10	0.2795	69.0	109.0	7.10
A9019/32	9/32	7.14	0.2813	75.0	108.0	7.14
A9017.2	–	7.20	0.2835	69.0	109.0	7.20
A9017.3	–	7.30	0.2874	69.0	109.0	7.30
A9017.4	–	7.40	0.2913	69.0	109.0	7.40
A9017.5	–	7.50	0.2953	69.0	109.0	7.50
A90119/64	19/64	7.54	0.2969	78.0	111.0	7.54
A9017.6	–	7.60	0.2992	75.0	117.0	7.60
A9017.7	–	7.70	0.3031	75.0	117.0	7.70
A9017.8	–	7.80	0.3071	75.0	117.0	7.80
A9017.9	–	7.90	0.3110	75.0	117.0	7.90
A9015/16	5/16	7.94	0.3125	81.0	114.0	7.94
A9018.0	–	8.00	0.3150	75.0	117.0	8.00
A9018.1	–	8.10	0.3189	75.0	117.0	8.10
A9018.2	–	8.20	0.3228	75.0	117.0	8.20
A9018.3	–	8.30	0.3268	75.0	117.0	8.30
A90121/64	21/64	8.33	0.3281	84.0	117.0	8.33
A9018.4	–	8.40	0.3307	75.0	117.0	8.40
A9018.5	–	8.50	0.3346	75.0	117.0	8.50
A9018.6	–	8.60	0.3386	81.0	125.0	8.60
A9018.7	–	8.70	0.3425	81.0	125.0	8.70
A90111/32	11/32	8.73	0.3438	87.0	121.0	8.73
A9018.8	–	8.80	0.3465	81.0	125.0	8.80
A9018.9	–	8.90	0.3504	81.0	125.0	8.90
A9019.0	–	9.00	0.3543	81.0	125.0	9.00
A9019.1	–	9.10	0.3583	81.0	125.0	9.10

Produit	DC	DC	DC	LCF	OAL	DCON MS
	(inch)	(mm)	(inch)	(mm)	(mm)	(mm)
A90123/64	23/64	9.13	0.3594	89.0	124.0	9.13
A9019.2	–	9.20	0.3622	81.0	125.0	9.20
A9019.3	–	9.30	0.3661	81.0	125.0	9.30
A9019.4	–	9.40	0.3701	81.0	125.0	9.40
A9019.5	–	9.50	0.3740	81.0	125.0	9.50
A9013/8	3/8	9.52	0.3750	92.0	127.0	9.52
A9019.6	–	9.60	0.3780	87.0	133.0	9.60
A9019.7	–	9.70	0.3819	87.0	133.0	9.70
A9019.8	–	9.80	0.3858	87.0	133.0	9.80
A9019.9	–	9.90	0.3898	87.0	133.0	9.90
A90125/64	25/64	9.92	0.3906	95.0	130.0	9.92
A90110.0	–	10.00	0.3937	87.0	133.0	10.00
A90110.2	–	10.20	0.4016	87.0	133.0	10.20
A90110.3	–	10.30	0.4055	87.0	133.0	10.30
A90113/32	13/32	10.32	0.4063	98.0	133.0	10.32
A90110.4	–	10.40	0.4094	87.0	133.0	10.40
A90110.5	–	10.50	0.4134	87.0	133.0	10.50
A90127/64	27/64	10.72	0.4219	100.0	137.0	10.72
A90110.8	–	10.80	0.4252	94.0	142.0	10.80
A90111.0	–	11.00	0.4331	94.0	142.0	11.00
A9017/16	7/16	11.11	0.4375	103.0	140.0	11.11
A90111.5	–	11.50	0.4528	94.0	142.0	11.50
A90129/64	29/64	11.51	0.4531	106.0	143.0	11.51
A90111.8	–	11.80	0.4646	94.0	142.0	11.80
A90115/32	15/32	11.91	0.4688	110.0	146.0	11.91
A90112.0	–	12.00	0.4724	101.0	151.0	12.00
A90131/64	31/64	12.30	0.4844	111.0	149.0	12.30
A90112.5	–	12.50	0.4921	101.0	151.0	12.50
A9011/2	1/2	12.70	0.5000	101.0	151.0	12.70
A90113.0	–	13.00	0.5118	101.0	151.0	13.00
A90133/64	33/64	13.10	0.5156	122.0	168.0	13.10
A90113.5	–	13.50	0.5315	108.0	160.0	13.50
A90135/64	35/64	13.89	0.5469	122.0	168.0	13.89
A90114.0	–	14.00	0.5512	108.0	160.0	14.00
A9019/16	9/16	14.29	0.5625	122.0	168.0	14.29
A90114.5	–	14.50	0.5709	114.0	169.0	14.50
A90137/64	37/64	14.68	0.5781	122.0	168.0	14.68
A90115.0	–	15.00	0.5906	114.0	169.0	15.00
A90119/32	19/32	15.08	0.5938	132.0	181.0	15.08
A90139/64	39/64	15.48	0.6094	132.0	181.0	15.48
A90115.5	–	15.50	0.6102	120.0	178.0	15.50
A9015/8	5/8	15.88	0.6250	132.0	181.0	15.88
A90116.0	–	16.00	0.6299	120.0	178.0	16.00



A170



Foret en HSS à queue réduite, finition avec traitement vapeur

Foret à queue cylindrique de ½ pouce (12,7 mm) permettant, même avec un grand diamètre de coupe, d'être serré dans des outils électriques conventionnels et portatifs. Une pointe à 118° facilite le réaffûtage. La finition avec traitement vapeur retient le fluide de coupe et empêche le collage des copeaux sur l'outil. Convient pour percer de nombreux matériaux.

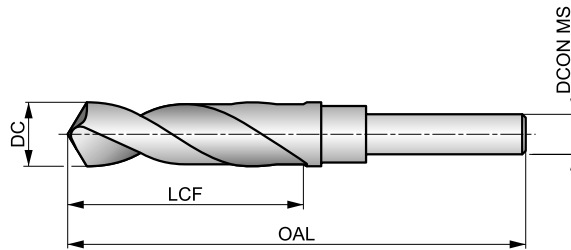

HSS	DORMER	4xD
118°	ST	
λ 20-35°	R	DC h8

Adéquation du groupe de matériaux de la pièce, valeurs de départ pour la vitesse de coupe (m/min) et code Alpha d'avance. Les tableaux d'avances par tour se trouvent à partir de la page 175.

P1.1 ■ 33 H	P1.2 ■ 37 H	P1.3 ■ 38 H	P2.1 ■ 28 H	P2.2 ■ 25 F	P2.3 ■ 22 D	P3.1 ■ 19 E	P3.2 ■ 15 E	P3.3 ■ 13 D	P4.1 ■ 11 E	P4.2 ■ 10 D	P4.3 ■ 8 C	M1.1 ■ 21 D	M1.2 ■ 17 D
M2.1 ■ 18 D	M2.2 ■ 15 D	M3.1 ■ 8 F	M3.2 ■ 7 F	M3.3 ■ 6 F	M4.1 ■ 7 B	K1.1 ■ 27 H	K1.2 ■ 20 E	K1.3 ■ 15 E	K2.1 ■ 23 D	K2.2 ■ 19 D	K2.3 ■ 15 D	K3.1 ■ 21 D	K3.2 ■ 16 D
K3.3 ■ 13 D	K4.1 ■ 19 D	K4.2 ■ 14 D	K4.3 ■ 11 D	K4.4 ■ 19 D	K4.5 ■ 8 D	K5.1 ■ 22 D	K5.2 ■ 16 D	K5.3 ■ 13 D	N1.1 ■ 33 I	N1.2 ■ 25 I	N1.3 ■ 17 H	N2.1 ■ 42 G	N2.2 ■ 37 G
N2.3 ■ 27 G	N3.1 ■ 56 G	N3.2 ■ 33 H	N3.3 ■ 17 F	N4.1 ■ 30 I	N4.2 ■ 28 G	N4.3 ■ 14 E	S1.1 ■ 17 E	S1.2 ■ 9 C	S1.3 ■ 5 A	S2.1 ■ 5 D	S2.2 ■ 4 A	S3.1 ■ 4 D	S3.2 ■ 3 A
S4.1 ■ 3 D	S4.2 ■ 2 A												

Produit	DC	DC	DC	LCF	OAL	LCF	OAL	DCON MS
	(inch)	(mm)	(inch)	(inch)	(inch)	(mm)	(mm)	
A17013.0	–	13.00	0.5118	–	–	83.0	156.0	12,7
A17033/64	33/64	13.10	0.5156	3.1/8	6"	–	–	12,7
A17017/32	17/32	13.49	0.5313	3.1/8	6"	–	–	12,7
A17013.5	–	13.50	0.5315	–	–	83.0	156.0	12,7
A17035/64	35/64	13.89	0.5469	3.1/8	6"	–	–	12,7
A17014.0	–	14.00	0.5512	–	–	83.0	156.0	12,7
A1709/16	9/16	14.29	0.5625	3.1/8	6"	–	–	12,7
A17014.5	–	14.50	0.5709	–	–	83.0	156.0	12,7
A17037/64	37/64	14.68	0.5781	3.1/8	6"	–	–	12,7
A17015.0	–	15.00	0.5906	–	–	83.0	156.0	12,7
A17019/32	19/32	15.08	0.5938	3.1/8	6"	–	–	12,7
A17039/64	39/64	15.48	0.6094	3.1/8	6"	–	–	12,7
A17015.5	–	15.50	0.6102	–	–	83.0	156.0	12,7
A1705/8	5/8	15.88	0.6250	3.1/8	6"	–	–	12,7
A17016.0	–	16.00	0.6299	–	–	84.0	157.0	12,7
A17041/64	41/64	16.27	0.6406	3.1/8	6"	–	–	12,7
A17016.5	–	16.50	0.6496	–	–	84.0	157.0	12,7
A17021/32	21/32	16.67	0.6563	3.1/8	6"	–	–	12,7
A17017.0	–	17.00	0.6693	–	–	84.0	157.0	12,7
A17043/64	43/64	17.07	0.6719	3.1/8	6"	–	–	12,7
A17011/16	11/16	17.46	0.6875	3.1/8	6"	–	–	12,7
A17017.5	–	17.50	0.6890	–	–	84.0	157.0	12,7
A17045/64	45/64	17.86	0.7031	3.1/8	6"	–	–	12,7
A17018.0	–	18.00	0.7087	–	–	84.0	157.0	12,7



Produit	DC	DC	DC	LCF	OAL	LCF	OAL	DCON MS
	(inch)	(mm)	(inch)	(inch)	(inch)	(mm)	(mm)	(mm)
A17023/32	23/32	18.26	0.7188	3.1/8	6"	—	—	12,7
A17018.5	—	18.50	0.7283	—	—	84.0	157.0	12,7
A17047/64	47/64	18.65	0.7344	3.1/8	6"	—	—	12,7
A17019.0	—	19.00	0.7480	—	—	84.0	157.0	12,7
A1703/4	3/4	19.05	0.7500	3.1/8	6"	—	—	12,7
A17049/64	49/64	19.45	0.7656	3"	6"	—	—	12,7
A17019.5	—	19.50	0.7677	—	—	81.0	158.0	12,7
A17025/32	25/32	19.84	0.7813	3"	6"	—	—	12,7
A17020.0	—	20.00	0.7874	—	—	81.0	158.0	12,7
A17051/64	51/64	20.24	0.7969	3"	6"	—	—	12,7
A17013/16	13/16	20.64	0.8125	3"	6"	—	—	12,7
A17021.0	—	21.00	0.8268	—	—	82.0	158.0	12,7
A17053/64	53/64	21.03	0.8281	3"	6"	—	—	12,7
A17027/32	27/32	21.43	0.8437	3"	6"	—	—	12,7
A17055/64	55/64	21.83	0.8594	3"	6"	—	—	12,7
A17022.0	—	22.00	0.8661	—	—	82.0	158.0	12,7
A1707/8	7/8	22.22	0.8750	3"	6"	—	—	12,7
A17057/64	57/64	22.62	0.8906	3"	6"	—	—	12,7
A17023.0	—	23.00	0.9055	—	—	82.0	158.0	12,7
A17029/32	29/32	23.02	0.9063	3"	6"	—	—	12,7
A17059/64	59/64	23.42	0.9219	3"	6"	—	—	12,7
A17015/16	15/16	23.81	0.9375	3"	6"	—	—	12,7
A17024.0	—	24.00	0.9449	—	—	83.0	159.0	12,7
A17061/64	61/64	24.21	0.9531	3"	6"	—	—	12,7
A17031/32	31/32	24.61	0.9688	3"	6"	—	—	12,7
A17025.0	—	25.00	0.9843	—	—	83.0	159.0	12,7
A17063/64	63/64	25.00	0.9844	3"	6"	—	—	12,7
A1701	1"	25.40	1.0000	3"	6"	—	—	12,7
A1701.1/32	1.1/32	26.19	1.0313	3"	6"	—	—	12,7
A1701.1/16	1.1/16	26.99	1.0625	3"	6"	—	—	12,7
A1701.7/64	1.7/64	28.18	1.1094	3"	6"	—	—	12,7
A1701.1/8	1.1/8	28.58	1.1250	3"	6"	—	—	12,7
A1701.9/64	1.9/64	28.97	1.1406	3"	6"	—	—	12,7
A1701.5/32	1.5/32	29.37	1.1563	3"	6"	—	—	12,7
A1701.3/16	1.3/16	30.16	1.1875	3"	6"	—	—	12,7
A1701.7/32	1.7/32	30.96	1.2188	3"	6"	—	—	12,7
A1701.1/4	1.1/4	31.75	1.2500	3"	6"	—	—	12,7
A1701.5/16	1.5/16	33.34	1.3125	3"	6"	—	—	12,7
A1701.3/8	1.3/8	34.93	1.3750	3"	6"	—	—	12,7
A1701.7/16	1.7/16	36.51	1.4375	3"	6"	—	—	12,7
A1701.1/2	1.1/2	38.10	1.5000	3"	6"	—	—	12,7



A243



Foret aéronautique série longue en HSS, finition brillante

Foret à la norme standard NAS907 équipé d'une pointe à 135° avec affûtage en croix qui facilite l'auto-centrage et empêche la pointe du foret de déraiper sur la surface du matériau. La grande longueur totale combinée à une courte longueur de goujure en fait un outil idéal pour le perçage dans les zones difficiles à atteindre et convient à de nombreux matériaux.

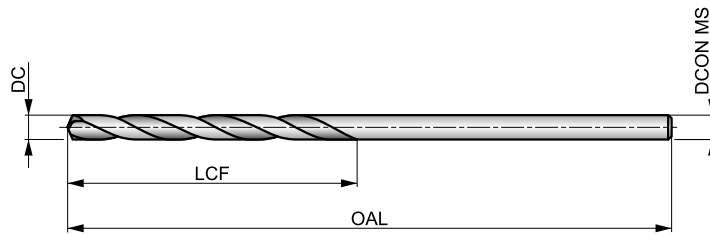

HSS	NAS 907	4xD
135°	Bright	
λ 20-35°	R	DC h8

Adéquation du groupe de matériaux de la pièce, valeurs de départ pour la vitesse de coupe (m/min) et code Alpha d'avance. Les tableaux d'avances par tour se trouvent à partir de la page 175.

P2.2 ▣ 25 F	P2.3 ▣ 22 E	P3.1 ▣ 19 F	P3.2 ▣ 15 F	P3.3 ▣ 13 E	P4.1 ▣ 11 F	P4.2 ▣ 10 E	P4.3 ▣ 8 D	M1.1 ▣ 21 E	M1.2 ▣ 17 E	M2.1 ▣ 18 E	M2.2 ▣ 15 E	M3.1 ▣ 9 G	M3.2 ▣ 8 G
M3.3 ▣ 7 G	M4.1 ▣ 9 C	K1.1 ▣ 30 I	K1.2 ▣ 22 F	K1.3 ▣ 17 F	K2.1 ▣ 25 E	K2.2 ▣ 20 E	K2.3 ▣ 16 E	K3.1 ▣ 22 E	K3.2 ▣ 17 E	K3.3 ▣ 13 E	K4.1 ▣ 20 E	K4.2 ▣ 15 E	K4.3 ▣ 11 E
K4.4 ▣ 10 E	K4.5 ▣ 8 E	K5.1 ▣ 23 E	K5.2 ▣ 17 E	K5.3 ▣ 13 E	N3.1 ▣ 27 H	S1.1 ▣ 23 F	S1.2 ▣ 12 D	S1.3 ▣ 6 B	S2.1 ▣ 8 E	S2.2 ▣ 4 A	S3.1 ▣ 6 E	S3.2 ▣ 3 A	S4.1 ▣ 5 E
S4.2 ▣ 2 A													

OAL 6" soit 150 mm.

Produit	DC (inch)	DC (inch)	LCF (inch)	OAL (inch)	DCON MS (inch)
A2433/32X6	3/32	0.0938	1.1/4	6"	0.0938
A243N40X6	N40	0.0980	1.3/8	6"	0.0980
A2431/8X6	1/8	0.1250	1.5/8	6"	0.1250
A243N30X6	N30	0.1285	1.5/8	6"	0.1285
A2435/32X6	5/32	0.1563	2"	6"	0.1563
A243N21X6	N21	0.1590	2.1/8	6"	0.1590

Produit	DC (inch)	DC (inch)	LCF (inch)	OAL (inch)	DCON MS (inch)
A243N20X6	N20	0.1610	2.1/8	6"	0.1610
A2433/16X6	3/16	0.1875	2.5/16	6"	0.1875
A243N11X6	N11	0.1910	2.5/16	6"	0.1910
A243N10X6	N10	0.1935	2.7/16	6"	0.1935
A2431/4X6	1/4	0.2500	2.3/4	6"	0.2500



A244



Foret aéronautique série longue en HSS, finition brillante

Foret à la norme standard NAS907 équipé d'une pointe à 118° avec affûtage en croix qui facilite l'auto-centrage et empêche la pointe du foret de dérapier sur la surface du matériau. La grande longueur totale combinée à une courte longueur de goujure en fait un outil idéal pour le perçage dans les zones difficiles à atteindre et convient à de nombreux matériaux.

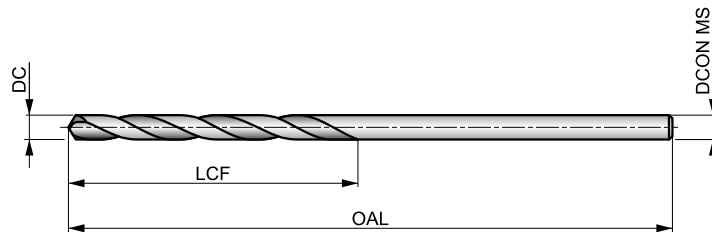

HSS	NAS 907	4xD
118°	Bright	
20-35°	R	DC h8

Adéquation du groupe de matériaux de la pièce, valeurs de départ pour la vitesse de coupe (m/min) et code Alpha d'avance. Les tableaux d'avances par tour se trouvent à partir de la page 175.

P2.2 ▣25 F	P2.3 ▣22 E	P3.1 ▣19 F	P3.2 ▣15 F	P3.3 ▣13 E	P4.1 ▣11 F	P4.2 ▣10 E	P4.3 ▣8 D	M1.1 ▣21 E	M1.2 ▣17 E	M2.1 ▣18 E	M2.2 ▣15 E	M3.1 ▣9 G	M3.2 ▣8 G
M3.3 ▣7 G	M4.1 ▣9 C	K1.1 ▣30 I	K1.2 ▣22 F	K1.3 ▣17 F	K2.1 ▣25 E	K2.2 ▣20 E	K2.3 ▣16 E	K3.1 ▣22 E	K3.2 ▣17 E	K3.3 ▣13 E	K4.1 ▣20 E	K4.2 ▣15 E	K4.3 ▣11 E
K4.4 ▣10 E	K4.5 ▣8 E	K5.1 ▣23 E	K5.2 ▣17 E	K5.3 ▣13 E	N3.1 ▣27 H	S1.1 ▣23 F	S1.2 ▣12 D	S1.3 ▣6 B	S2.1 ▣8 E	S2.2 ▣4 A	S3.1 ▣6 E	S3.2 ▣3 A	S4.1 ▣5 E
S4.2 ▣2 A													

OAL 6" soit 150 mm.

Produit	DC	DC	LCF	OAL	DCON MS
	(inch)	(inch)	(inch)	(inch)	(inch)
A2441/8X6	1/8	0.1250	1.5/8	6"	0.1250
A2445/32X6	5/32	0.1563	2"	6"	0.1563
A2443/16X6	3/16	0.1875	2.5/16	6"	0.1875
A2441/4X6	1/4	0.2500	2.3/4	6"	0.2500



A110



Foret série longue en HSS, finition avec traitement vapeur

Foret pour perçage de trous plus profonds. Sa pointe conventionnelle à 118° offre de la résistance et est facile à réaffûter ce qui la rend très économique. Convient pour percer de nombreux matériaux. La finition avec traitement vapeur retient le fluide de coupe et empêche le collage des copeaux sur l'outil. Pour le perçage manuel et sur machines.

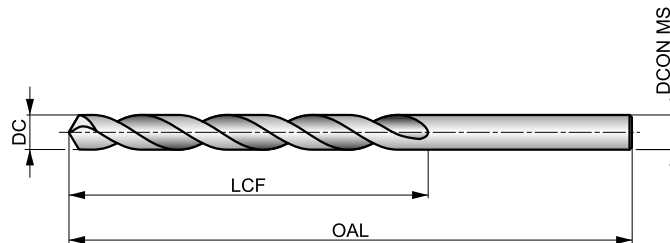

HSS	DIN 340	6xD
118°	ST	
λ 20-35°	R	DC h8

Adéquation du groupe de matériaux de la pièce, valeurs de départ pour la vitesse de coupe (m/min) et code Alpha d'avance. Les tableaux d'avances par tour se trouvent à partir de la page 175.

P1.1 ■ 27 G	P1.2 ■ 30 G	P1.3 ■ 31 G	P2.1 ■ 23 G	P2.2 ■ 20 E	P2.3 ■ 18 D	P3.1 ■ 13 E	P3.2 ■ 11 E	P3.3 ■ 9 D	P4.1 ■ 8 E	P4.2 ■ 7 D	P4.3 ■ 5 B	M1.1 ■ 14 D	M1.2 ■ 12 D
M2.1 ■ 12 D	M2.2 ■ 10 D	M3.1 ■ 7 F	M3.2 ■ 6 F	M3.3 ■ 5 F	M4.1 ■ 4 B	K1.1 ■ 28 H	K1.2 ■ 21 E	K1.3 ■ 16 E	K2.1 ■ 18 D	K2.2 ■ 15 D	K2.3 ■ 12 D	K3.1 ■ 16 D	K3.2 ■ 12 D
K3.3 ■ 10 D	K4.1 ■ 15 D	K4.2 ■ 11 D	K4.3 ■ 8 D	K4.4 ■ 7 D	K4.5 ■ 6 D	K5.1 ■ 17 D	K5.2 ■ 13 D	K5.3 ■ 10 D	N1.1 ■ 32 I	N1.2 ■ 24 I	N1.3 ■ 16 H	N2.1 ■ 42 G	N2.2 ■ 37 G
N2.3 ■ 27 G	N3.1 ■ 54 G	N3.2 ■ 32 H	N3.3 ■ 16 E	N4.1 ■ 35 I	N4.2 ■ 26 G	N4.3 ■ 12 E	S1.1 ■ 17 E	S1.2 ■ 9 C	S1.3 ■ 4 A	S2.1 ■ 5 D	S2.2 ■ 4 A	S3.1 ■ 4 D	S3.2 ■ 3 A
S4.1 ■ 3 D	S4.2 ■ 2 A												

DC <= 1mm; 1/16" Brillant.

Produit	DC	DC	DC	LCF	OAL	DCON MS
	(inch)	(mm)	(inch)			
A110.5	-	0.50	0.0197	12.0	32.0	0.50
A110.6	-	0.60	0.0236	15.0	35.0	0.60
A110.7	-	0.70	0.0276	21.0	42.0	0.70
A1101/32	1/32	0.79	0.0313	25.0	46.0	0.79
A110.8	-	0.80	0.0315	25.0	46.0	0.80
A110.9	-	0.90	0.0354	29.0	51.0	0.90
A1101.0	-	1.00	0.0394	33.0	56.0	1.00
A1101.1	-	1.10	0.0433	37.0	60.0	1.10
A1101.2	-	1.20	0.0472	41.0	65.0	1.20
A1101.3	-	1.30	0.0512	41.0	65.0	1.30
A1101.4	-	1.40	0.0551	45.0	70.0	1.40
A1101.5	-	1.50	0.0591	45.0	70.0	1.50
A1101/16	1/16	1.59	0.0625	50.0	76.0	1.59
A1101.6	-	1.60	0.0630	50.0	76.0	1.60
A1101.7	-	1.70	0.0669	50.0	76.0	1.70
A1101.75	-	1.75	0.0689	53.0	80.0	1.75
A1101.8	-	1.80	0.0709	53.0	80.0	1.80
A1101.9	-	1.90	0.0748	53.0	80.0	1.90
A1105/64	5/64	1.98	0.0781	56.0	85.0	1.98
A1102.0	-	2.00	0.0787	56.0	85.0	2.00
A1102.05	-	2.05	0.0807	56.0	85.0	2.05
A1102.1	-	2.10	0.0827	56.0	85.0	2.10
A1102.2	-	2.20	0.0866	59.0	90.0	2.20
A1102.25	-	2.25	0.0886	59.0	90.0	2.25

Produit	DC	DC	DC	LCF	OAL	DCON MS
	(inch)	(mm)	(inch)			
A1102.3	-	2.30	0.0906	59.0	90.0	2.30
A1103/32	3/32	2.38	0.0938	62.0	95.0	2.38
A1102.4	-	2.40	0.0945	62.0	95.0	2.40
A1102.5	-	2.50	0.0984	62.0	95.0	2.50
A1102.6	-	2.60	0.1024	62.0	95.0	2.60
A1102.7	-	2.70	0.1063	66.0	100.0	2.70
A1107/64	7/64	2.78	0.1094	66.0	100.0	2.78
A1102.8	-	2.80	0.1102	66.0	100.0	2.80
A1102.9	-	2.90	0.1142	66.0	100.0	2.90
A1103.0	-	3.00	0.1181	66.0	100.0	3.00
A1103.1	-	3.10	0.1220	69.0	106.0	3.10
A1101/8	1/8	3.18	0.1250	69.0	106.0	3.18
A1103.2	-	3.20	0.1260	69.0	106.0	3.20
A1103.25	-	3.25	0.1280	69.0	106.0	3.25
A1103.3	-	3.30	0.1299	69.0	106.0	3.30
A1103.4	-	3.40	0.1339	73.0	112.0	3.40
A1103.5	-	3.50	0.1378	73.0	112.0	3.50
A1109/64	9/64	3.57	0.1406	73.0	112.0	3.57
A1103.6	-	3.60	0.1417	73.0	112.0	3.60
A1103.7	-	3.70	0.1457	73.0	112.0	3.70
A1103.75	-	3.75	0.1476	73.0	112.0	3.75
A1103.8	-	3.80	0.1496	78.0	119.0	3.80
A1103.9	-	3.90	0.1535	78.0	119.0	3.90
A1105/32	5/32	3.97	0.1563	78.0	119.0	3.97



A940



Foret série longue PFX en HSS-E (5% cobalt), finition brillante

Foret haute performance capable de produire des trous de haute qualité et précis à des vitesses et des avances élevées (tolérance de trou H10). Sa pointe auto-centrante à 130° et la conception spéciale de sa goujure parabolique permettent de percer des trous très profonds en une seule passe. Convient à de nombreux matériaux.

PFX

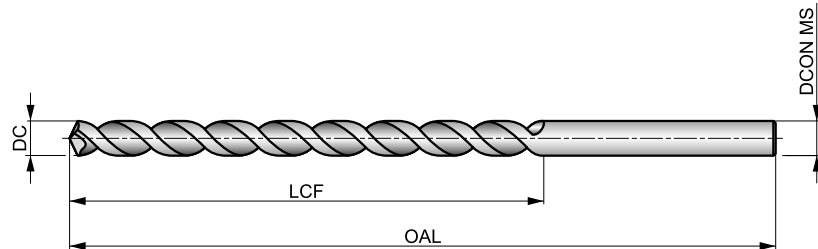

HSS-E	DIN ANSI	10xD
130°	Bright	
λ > 35°	R	DC h8

Adéquation du groupe de matériaux de la pièce, valeurs de départ pour la vitesse de coupe (m/min) et code Alpha d'avance. Les tableaux d'avances par tour se trouvent à partir de la page 175.

P1.1 ■ 29 F	P1.2 ■ 33 F	P1.3 ■ 34 F	P2.1 ■ 25 F	P2.2 ■ 22 G	P2.3 ■ 19 C	P3.1 ■ 25 G	P3.2 ■ 20 G	P3.3 ■ 17 C	P4.1 ■ 15 G	P4.2 ■ 13 C	P4.3 ■ 10 C	M1.1 ■ 21 C	M1.2 ■ 17 C
M2.1 ■ 18 C	M2.2 ■ 15 C	M3.1 ■ 8 E	M3.2 ■ 7 E	M3.3 ■ 6 E	M4.1 ■ 9 B	K2.1 ■ 20 I	K2.2 ■ 16 I	K2.3 ■ 13 H	K3.1 ■ 17 I	K3.2 ■ 13 I	K3.3 ■ 11 H	K4.1 ■ 16 I	K4.2 ■ 12 I
K4.3 ■ 9 H	K4.4 ■ 8 H	K4.5 ■ 6 H	K5.1 ■ 18 I	K5.2 ■ 14 I	K5.3 ■ 11 H	N1.1 ■ 53 H	N1.2 ■ 40 H	N1.3 ■ 27 N	N2.1 ■ 62 N	N2.2 ■ 55 N	N2.3 ■ 40 N	N3.1 ■ 119 G	N3.2 ■ 70 F
N3.3 ■ 35 F	N4.1 ■ 55 H	N4.2 ■ 40 F	S1.1 ■ 18 E	S1.2 ■ 13 C	S1.3 ■ 6 C								

DC >= 9.6mm moins de 10xD.

Produit	DC	DC	DC	LCF	OAL	DCON MS
	(inch)	(mm)	(inch)			
A9401.0	-	1.00	0.0394	33.0	56.0	1.00
A9401.1	-	1.10	0.0433	37.0	60.0	1.10
A9403/64	3/64	1.19	0.0469	29.0	57.0	1.19
A9401.2	-	1.20	0.0472	41.0	65.0	1.20
A9401.3	-	1.30	0.0512	41.0	65.0	1.30
A9401.4	-	1.40	0.0551	45.0	70.0	1.40
A9401.5	-	1.50	0.0591	45.0	70.0	1.50
A9401/16	1/16	1.59	0.0625	44.0	76.0	1.59
A9401.6	-	1.60	0.0630	50.0	76.0	1.60
A9401.7	-	1.70	0.0669	50.0	76.0	1.70
A9401.8	-	1.80	0.0709	53.0	80.0	1.80
A9401.9	-	1.90	0.0748	53.0	80.0	1.90
A9405/64	5/64	1.98	0.0781	51.0	95.0	1.98
A9402.0	-	2.00	0.0787	56.0	85.0	2.00
A9402.1	-	2.10	0.0827	56.0	85.0	2.10
A9402.2	-	2.20	0.0866	59.0	90.0	2.20
A9402.3	-	2.30	0.0906	59.0	90.0	2.30
A9403/32	3/32	2.38	0.0938	57.0	108.0	2.38
A9402.4	-	2.40	0.0945	62.0	95.0	2.40
A9402.5	-	2.50	0.0984	62.0	95.0	2.50
A9402.6	-	2.60	0.1024	62.0	95.0	2.60
A9402.7	-	2.70	0.1063	66.0	100.0	2.70
A9407/64	7/64	2.78	0.1094	64.0	117.0	2.78
A9402.8	-	2.80	0.1102	66.0	100.0	2.80
A9402.9	-	2.90	0.1142	66.0	100.0	2.90

Produit	DC	DC	DC	LCF	OAL	DCON MS
	(inch)	(mm)	(inch)			
A9403.0	-	3.00	0.1181	66.0	100.0	3.00
A9403.1	-	3.10	0.1220	69.0	106.0	3.10
A9401/8	1/8	3.18	0.1250	70.0	130.0	3.18
A9403.2	-	3.20	0.1260	69.0	106.0	3.20
A9403.3	-	3.30	0.1299	69.0	106.0	3.30
A9403.4	-	3.40	0.1339	73.0	112.0	3.40
A9403.5	-	3.50	0.1378	73.0	112.0	3.50
A9409/64	9/64	3.57	0.1406	76.0	137.0	3.57
A9403.6	-	3.60	0.1417	73.0	112.0	3.60
A9403.7	-	3.70	0.1457	73.0	112.0	3.70
A9403.8	-	3.80	0.1496	78.0	119.0	3.80
A9403.9	-	3.90	0.1535	78.0	119.0	3.90
A9405/32	5/32	3.97	0.1563	76.0	137.0	3.97
A9404.0	-	4.00	0.1575	78.0	119.0	4.00
A9404.1	-	4.10	0.1614	78.0	119.0	4.10
A9404.2	-	4.20	0.1654	78.0	119.0	4.20
A9404.3	-	4.30	0.1693	82.0	126.0	4.30
A94011/64	11/64	4.37	0.1719	86.0	146.0	4.37
A9404.4	-	4.40	0.1732	82.0	126.0	4.40
A9404.5	-	4.50	0.1772	82.0	126.0	4.50
A9404.6	-	4.60	0.1811	82.0	126.0	4.60
A9404.7	-	4.70	0.1850	82.0	126.0	4.70
A9403/16	3/16	4.76	0.1875	86.0	146.0	4.76
A9404.8	-	4.80	0.1890	87.0	132.0	4.80
A9404.9	-	4.90	0.1929	87.0	132.0	4.90



Produit	DC	DC	DC	LCF	OAL	D CON MS
	(inch)	(mm)	(inch)	(mm)	(mm)	(mm)
A9405.0	–	5.00	0.1969	87.0	132.0	5.00
A9405.1	–	5.10	0.2008	87.0	132.0	5.10
A94013/64	13/64	5.16	0.2031	92.0	152.0	5.16
A9405.2	–	5.20	0.2047	87.0	132.0	5.20
A9405.3	–	5.30	0.2087	87.0	132.0	5.30
A9405.4	–	5.40	0.2126	91.0	139.0	5.40
A9405.5	–	5.50	0.2165	91.0	139.0	5.50
A9407/32	7/32	5.56	0.2188	92.0	152.0	5.56
A9405.6	–	5.60	0.2205	91.0	139.0	5.60
A9405.7	–	5.70	0.2244	91.0	139.0	5.70
A9405.8	–	5.80	0.2283	91.0	139.0	5.80
A9405.9	–	5.90	0.2323	91.0	139.0	5.90
A94015/64	15/64	5.95	0.2344	95.0	156.0	5.95
A9406.0	–	6.00	0.2362	91.0	139.0	6.00
A9406.1	–	6.10	0.2402	97.0	148.0	6.10
A9406.2	–	6.20	0.2441	97.0	148.0	6.20
A9406.3	–	6.30	0.2480	97.0	148.0	6.30
A9401/4	1/4	6.35	0.2500	95.0	156.0	6.35
A9406.4	–	6.40	0.2520	97.0	148.0	6.40
A9406.5	–	6.50	0.2559	97.0	148.0	6.50
A9406.6	–	6.60	0.2598	97.0	148.0	6.60
A9406.7	–	6.70	0.2638	97.0	148.0	6.70
A94017/64	17/64	6.75	0.2656	98.0	159.0	6.75
A9406.8	–	6.80	0.2677	102.0	156.0	6.80
A9406.9	–	6.90	0.2717	102.0	156.0	6.90
A9407.0	–	7.00	0.2756	102.0	156.0	7.00
A9407.1	–	7.10	0.2795	102.0	156.0	7.10
A9409/32	9/32	7.14	0.2813	98.0	159.0	7.14
A9407.2	–	7.20	0.2835	102.0	156.0	7.20
A9407.3	–	7.30	0.2874	102.0	156.0	7.30
A9407.4	–	7.40	0.2913	102.0	156.0	7.40
A9407.5	–	7.50	0.2953	102.0	156.0	7.50
A94019/64	19/64	7.54	0.2969	102.0	162.0	7.54
A9407.6	–	7.60	0.2992	109.0	165.0	7.60
A9407.7	–	7.70	0.3031	109.0	165.0	7.70
A9407.8	–	7.80	0.3071	109.0	165.0	7.80
A9407.9	–	7.90	0.3110	109.0	165.0	7.90
A9405/16	5/16	7.94	0.3125	102.0	162.0	7.94
A9408.0	–	8.00	0.3150	109.0	165.0	8.00
A9408.1	–	8.10	0.3189	109.0	165.0	8.10
A9408.2	–	8.20	0.3228	109.0	165.0	8.20
A9408.3	–	8.30	0.3268	109.0	165.0	8.30
A94021/64	21/64	8.33	0.3281	105.0	165.0	8.33
A9408.4	–	8.40	0.3307	109.0	165.0	8.40
A9408.5	–	8.50	0.3346	109.0	165.0	8.50
A9408.6	–	8.60	0.3386	115.0	175.0	8.60
A9408.7	–	8.70	0.3425	115.0	175.0	8.70
A94011/32	11/32	8.73	0.3438	105.0	165.0	8.73
A9408.8	–	8.80	0.3465	115.0	175.0	8.80
A9408.9	–	8.90	0.3504	115.0	175.0	8.90
A9409.0	–	9.00	0.3543	115.0	175.0	9.00
A9409.1	–	9.10	0.3583	115.0	175.0	9.10
A94023/64	23/64	9.13	0.3594	108.0	171.0	9.13
A9409.2	–	9.20	0.3622	115.0	175.0	9.20
A9409.3	–	9.30	0.3661	115.0	175.0	9.30
A9409.4	–	9.40	0.3701	115.0	175.0	9.40

Produit	DC	DC	DC	LCF	OAL	D CON MS
	(inch)	(mm)	(inch)	(mm)	(mm)	(mm)
A9409.5	–	9.50	0.3740	115.0	175.0	9.50
A9403/8	3/8	9.52	0.3750	108.0	171.0	9.52
A9409.6	–	9.60	0.3780	121.0	184.0	9.60
A9409.7	–	9.70	0.3819	121.0	184.0	9.70
A9409.8	–	9.80	0.3858	121.0	184.0	9.80
A9409.9	–	9.90	0.3898	121.0	184.0	9.90
A94025/64	25/64	9.92	0.3906	111.0	178.0	9.92
A94010.0	–	10.00	0.3937	121.0	184.0	10.00
A94010.2	–	10.20	0.4016	121.0	184.0	10.20
A94010.3	–	10.30	0.4055	121.0	184.0	10.30
A94013/32	13/32	10.32	0.4063	111.0	178.0	10.32
A94010.5	–	10.50	0.4134	121.0	184.0	10.50
A94027/64	27/64	10.72	0.4219	117.0	184.0	10.72
A94011.0	–	11.00	0.4331	128.0	195.0	11.00
A9407/16	7/16	11.11	0.4375	117.0	184.0	11.11
A94011.2	–	11.20	0.4409	128.0	195.0	11.20
A94011.5	–	11.50	0.4528	128.0	195.0	11.50
A94029/64	29/64	11.51	0.4531	121.0	190.0	11.51
A94011.8	–	11.80	0.4646	128.0	195.0	11.80
A94015/32	15/32	11.91	0.4688	121.0	190.0	11.91
A94012.0	–	12.00	0.4724	134.0	205.0	12.00
A94012.2	–	12.20	0.4803	134.0	205.0	12.20
A94031/64	31/64	12.30	0.4844	121.0	197.0	12.30
A94012.5	–	12.50	0.4921	134.0	205.0	12.50
A9401/2	1/2	12.70	0.5000	121.0	197.0	12.70
A94013.0	–	13.00	0.5118	134.0	205.0	13.00
A94033/64	33/64	13.10	0.5156	121.0	203.0	13.10
A94017/32	17/32	13.49	0.5313	121.0	203.0	13.49
A94013.5	–	13.50	0.5315	140.0	214.0	13.50
A94035/64	35/64	13.89	0.5469	124.0	210.0	13.89
A94014.0	–	14.00	0.5512	140.0	214.0	14.00
A9409/16	9/16	14.29	0.5625	124.0	210.0	14.29
A94014.5	–	14.50	0.5709	144.0	220.0	14.50
A94037/64	37/64	14.68	0.5781	124.0	222.0	14.68
A94015.0	–	15.00	0.5906	144.0	220.0	15.00
A94019/32	19/32	15.08	0.5938	124.0	222.0	15.08
A94039/64	39/64	15.48	0.6094	124.0	222.0	15.48
A94015.5	–	15.50	0.6102	149.0	227.0	15.50
A9405/8	5/8	15.88	0.6250	124.0	222.0	15.88
A94016.0	–	16.00	0.6299	149.0	227.0	16.00
A94041/64	41/64	16.27	0.6406	130.0	229.0	16.27
A94016.5	–	16.50	0.6496	154.0	235.0	16.50
A94021/32	21/32	16.67	0.6563	130.0	229.0	16.67
A94017.0	–	17.00	0.6693	154.0	235.0	17.00
A94043/64	43/64	17.07	0.6719	137.0	235.0	17.07
A94011/16	11/16	17.46	0.6875	137.0	235.0	17.46
A94017.5	–	17.50	0.6890	158.0	241.0	17.50
A94045/64	45/64	17.86	0.7031	143.0	241.0	17.86
A94018.0	–	18.00	0.7087	158.0	241.0	18.00
A94023/32	23/32	18.26	0.7188	143.0	241.0	18.26
A94047/64	47/64	18.65	0.7344	149.0	248.0	18.65
A94019.0	–	19.00	0.7480	162.0	247.0	19.00
A9403/4	3/4	19.05	0.7500	149.0	248.0	19.05
A94049/64	49/64	19.45	0.7656	152.0	251.0	19.45
A94025/32	25/32	19.84	0.7813	152.0	251.0	19.84
A94020.0	–	20.00	0.7874	166.0	254.0	20.00



A941



Foret série longue PFX en HSS-E (5% cobalt), revêtement Alcrona

Foret haute performance capable de produire des trous de haute qualité et précis à des vitesses et des avances élevées (tolérance de trou H10). Il possède une pointe auto-centrante à 130° et une conception spéciale de goujure parabolique. Convient à de nombreux matériaux. Le revêtement Alcrona-TOP améliore les performances et prolonge la durée de vie de l'outil.



PFX

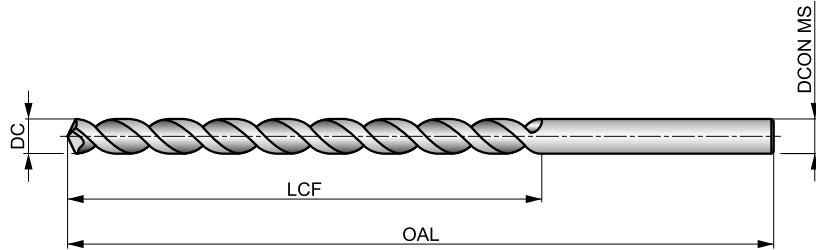

HSS-E	DIN ANSI	10xD
130°	Alcrona Top	
λ > 35°	R	DC h8

Adéquation du groupe de matériaux de la pièce, valeurs de départ pour la vitesse de coupe (m/min) et code Alpha d'avance. Les tableaux d'avances par tour se trouvent à partir de la page 175.

P1.1 ■ 48 G	P1.2 ■ 53 G	P1.3 ■ 55 G	P2.1 ■ 41 G	P2.2 ■ 36 G	P2.3 ■ 32 D	P3.1 ■ 34 G	P3.2 ■ 27 G	P3.3 ■ 23 D	P4.1 ■ 20 G	P4.2 ■ 17 D	P4.3 ■ 14 D	M1.1 ■ 23 C	M1.2 ■ 20 C
M2.1 ■ 21 C	M2.2 ■ 17 C	M3.1 ■ 10 E	M3.2 ■ 9 E	M3.3 ■ 8 E	M4.1 ■ 11 B	K1.1 ■ 36 I	K1.2 ■ 27 I	K1.3 ■ 20 I	K2.1 ■ 37 I	K2.2 ■ 30 I	K2.3 ■ 24 H	K3.1 ■ 33 I	K3.2 ■ 25 I
K3.3 ■ 20 H	K4.1 ■ 30 I	K4.2 ■ 23 I	K4.3 ■ 17 H	K4.4 ■ 14 H	K4.5 ■ 12 H	K5.1 ■ 34 I	K5.2 ■ 26 I	K5.3 ■ 20 H	S1.1 ■ 25 F	S1.2 ■ 18 D	S1.3 ■ 18 D		

DC >= 9.6mm moins de 10xD.

Produit	DC	DC	DC	LCF	OAL	DCON MS
	(inch)	(mm)	(inch)			
A9411.0	-	1.00	0.0394	33.0	56.0	1.00
A9413/64	3/64	1.19	0.0469	29.0	57.0	1.19
A9411.5	-	1.50	0.0591	45.0	70.0	1.50
A9411/16	1/16	1.59	0.0625	44.0	76.0	1.59
A9415/64	5/64	1.98	0.0781	51.0	95.0	1.98
A9412.0	-	2.00	0.0787	56.0	85.0	2.00
A9413/32	3/32	2.38	0.0938	57.0	108.0	2.38
A9412.5	-	2.50	0.0984	62.0	95.0	2.50
A9417/64	7/64	2.78	0.1094	64.0	117.0	2.78
A9413.0	-	3.00	0.1181	66.0	100.0	3.00
A9413.1	-	3.10	0.1220	69.0	106.0	3.10
A9411/8	1/8	3.18	0.1250	70.0	130.0	3.18
A9413.2	-	3.20	0.1260	69.0	106.0	3.20
A9413.3	-	3.30	0.1299	69.0	106.0	3.30
A9413.4	-	3.40	0.1339	73.0	112.0	3.40
A9413.5	-	3.50	0.1378	73.0	112.0	3.50
A9419/64	9/64	3.57	0.1406	76.0	137.0	3.57
A9413.6	-	3.60	0.1417	73.0	112.0	3.60
A9413.7	-	3.70	0.1457	73.0	112.0	3.70
A9413.8	-	3.80	0.1496	78.0	119.0	3.80
A9413.9	-	3.90	0.1535	78.0	119.0	3.90
A9415/32	5/32	3.97	0.1563	76.0	137.0	3.97
A9414.0	-	4.00	0.1575	78.0	119.0	4.00
A9414.1	-	4.10	0.1614	78.0	119.0	4.10
A9414.2	-	4.20	0.1654	78.0	119.0	4.20
A9414.3	-	4.30	0.1693	82.0	126.0	4.30
A94111/64	11/64	4.37	0.1719	86.0	146.0	4.37

Produit	DC	DC	DC	LCF	OAL	DCON MS
	(inch)	(mm)	(inch)			
A9414.4	-	4.40	0.1732	82.0	126.0	4.40
A9414.5	-	4.50	0.1772	82.0	126.0	4.50
A9414.6	-	4.60	0.1811	82.0	126.0	4.60
A9414.7	-	4.70	0.1850	82.0	126.0	4.70
A9413/16	3/16	4.76	0.1875	86.0	146.0	4.76
A9414.8	-	4.80	0.1890	87.0	132.0	4.80
A9414.9	-	4.90	0.1929	87.0	132.0	4.90
A9415.0	-	5.00	0.1969	87.0	132.0	5.00
A9415.1	-	5.10	0.2008	87.0	132.0	5.10
A94113/64	13/64	5.16	0.2031	92.0	152.0	5.16
A9415.2	-	5.20	0.2047	87.0	132.0	5.20
A9415.3	-	5.30	0.2087	87.0	132.0	5.30
A9415.4	-	5.40	0.2126	91.0	139.0	5.40
A9415.5	-	5.50	0.2165	91.0	139.0	5.50
A9417/32	7/32	5.56	0.2188	92.0	152.0	5.56
A9415.6	-	5.60	0.2205	91.0	139.0	5.60
A9415.7	-	5.70	0.2244	91.0	139.0	5.70
A9415.8	-	5.80	0.2283	91.0	139.0	5.80
A9415.9	-	5.90	0.2323	91.0	139.0	5.90
A94115/64	15/64	5.95	0.2344	95.0	156.0	5.95
A9416.0	-	6.00	0.2362	91.0	139.0	6.00
A9416.1	-	6.10	0.2402	97.0	148.0	6.10
A9416.2	-	6.20	0.2441	97.0	148.0	6.20
A9416.3	-	6.30	0.2480	97.0	148.0	6.30
A9411/4	1/4	6.35	0.2500	95.0	156.0	6.35
A9416.4	-	6.40	0.2520	97.0	148.0	6.40
A9416.5	-	6.50	0.2559	97.0	148.0	6.50



Produit	DC	DC	DC	LCF	OAL	DCON MS
	(inch)	(mm)	(inch)	(mm)	(mm)	(mm)
A9416.6	–	6.60	0.2598	97.0	148.0	6.60
A9416.7	–	6.70	0.2638	97.0	148.0	6.70
A94117/64	17/64	6.75	0.2656	98.0	159.0	6.75
A9416.8	–	6.80	0.2677	102.0	156.0	6.80
A9416.9	–	6.90	0.2717	102.0	156.0	6.90
A9417.0	–	7.00	0.2756	102.0	156.0	7.00
A9417.1	–	7.10	0.2795	102.0	156.0	7.10
A9419/32	9/32	7.14	0.2813	98.0	159.0	7.14
A9417.2	–	7.20	0.2835	102.0	156.0	7.20
A9417.3	–	7.30	0.2874	102.0	156.0	7.30
A9417.4	–	7.40	0.2913	102.0	156.0	7.40
A9417.5	–	7.50	0.2953	102.0	156.0	7.50
A94119/64	19/64	7.54	0.2969	102.0	162.0	7.54
A9417.6	–	7.60	0.2992	109.0	165.0	7.60
A9417.7	–	7.70	0.3031	109.0	165.0	7.70
A9417.8	–	7.80	0.3071	109.0	165.0	7.80
A9417.9	–	7.90	0.3110	109.0	165.0	7.90
A9415/16	5/16	7.94	0.3125	102.0	162.0	7.94
A9418.0	–	8.00	0.3150	109.0	165.0	8.00
A9418.1	–	8.10	0.3189	109.0	165.0	8.10
A9418.2	–	8.20	0.3228	109.0	165.0	8.20
A9418.3	–	8.30	0.3268	109.0	165.0	8.30
A94121/64	21/64	8.33	0.3281	105.0	165.0	8.33
A9418.4	–	8.40	0.3307	109.0	165.0	8.40
A9418.5	–	8.50	0.3346	109.0	165.0	8.50
A9418.6	–	8.60	0.3386	115.0	175.0	8.60
A9418.7	–	8.70	0.3425	115.0	175.0	8.70
A94111/32	11/32	8.73	0.3438	105.0	165.0	8.73
A9418.8	–	8.80	0.3465	115.0	175.0	8.80
A9418.9	–	8.90	0.3504	115.0	175.0	8.90
A9419.0	–	9.00	0.3543	115.0	175.0	9.00
A9419.1	–	9.10	0.3583	115.0	175.0	9.10
A94123/64	23/64	9.13	0.3594	108.0	171.0	9.13
A9419.2	–	9.20	0.3622	115.0	175.0	9.20
A9419.3	–	9.30	0.3661	115.0	175.0	9.30
A9419.4	–	9.40	0.3701	115.0	175.0	9.40
A9419.5	–	9.50	0.3740	115.0	175.0	9.50
A9413/8	3/8	9.52	0.3750	108.0	171.0	9.52

Produit	DC	DC	DC	LCF	OAL	DCON MS
	(inch)	(mm)	(inch)	(mm)	(mm)	(mm)
A9419.6	–	9.60	0.3780	121.0	184.0	9.60
A9419.7	–	9.70	0.3819	121.0	184.0	9.70
A9419.8	–	9.80	0.3858	121.0	184.0	9.80
A9419.9	–	9.90	0.3898	121.0	184.0	9.90
A94125/64	25/64	9.92	0.3906	111.0	178.0	9.92
A94110.0	–	10.00	0.3937	121.0	184.0	10.00
A94110.2	–	10.20	0.4016	121.0	184.0	10.20
A94110.3	–	10.30	0.4055	121.0	184.0	10.30
A94113/32	13/32	10.32	0.4063	111.0	178.0	10.32
A94110.5	–	10.50	0.4134	121.0	184.0	10.50
A94127/64	27/64	10.72	0.4219	117.0	184.0	10.72
A94111.0	–	11.00	0.4331	128.0	195.0	11.00
A9417/16	7/16	11.11	0.4375	117.0	184.0	11.11
A94111.2	–	11.20	0.4409	128.0	195.0	11.20
A94111.5	–	11.50	0.4528	128.0	195.0	11.50
A94129/64	29/64	11.51	0.4531	121.0	190.0	11.51
A94111.8	–	11.80	0.4646	128.0	195.0	11.80
A94115/32	15/32	11.91	0.4688	121.0	190.0	11.91
A94112.0	–	12.00	0.4724	134.0	205.0	12.00
A94112.2	–	12.20	0.4803	134.0	205.0	12.20
A94131/64	31/64	12.30	0.4844	121.0	197.0	12.30
A94112.5	–	12.50	0.4921	134.0	205.0	12.50
A9411/2	1/2	12.70	0.5000	121.0	197.0	12.70
A94113.0	–	13.00	0.5118	134.0	205.0	13.00
A94133/64	33/64	13.10	0.5156	121.0	203.0	13.10
A94113.5	–	13.50	0.5315	140.0	214.0	13.50
A94135/64	35/64	13.89	0.5469	124.0	210.0	13.89
A94114.0	–	14.00	0.5512	140.0	214.0	14.00
A9419/16	9/16	14.29	0.5625	124.0	210.0	14.29
A94114.5	–	14.50	0.5709	144.0	220.0	14.50
A94137/64	37/64	14.68	0.5781	124.0	222.0	14.68
A94115.0	–	15.00	0.5906	144.0	220.0	15.00
A94119/32	19/32	15.08	0.5938	124.0	222.0	15.08
A94139/64	39/64	15.48	0.6094	124.0	222.0	15.48
A94115.5	–	15.50	0.6102	149.0	227.0	15.50
A9415/8	5/8	15.88	0.6250	124.0	222.0	15.88
A94116.0	–	16.00	0.6299	149.0	227.0	16.00



A125



Foret série extra-longue en HSS, finition avec traitement vapeur

Foret avec finition traitement vapeur recommandé pour les trous très profonds ou difficilement accessibles. Pointe conventionnelle à 118° offrant de la résistance et permettant d'économiser sur les affûtages simples. Convient à de nombreux matériaux. La finition avec traitement vapeur retient le liquide de coupe et empêche le collage des copeaux sur l'outil. Moins adapté au perçage à la main.

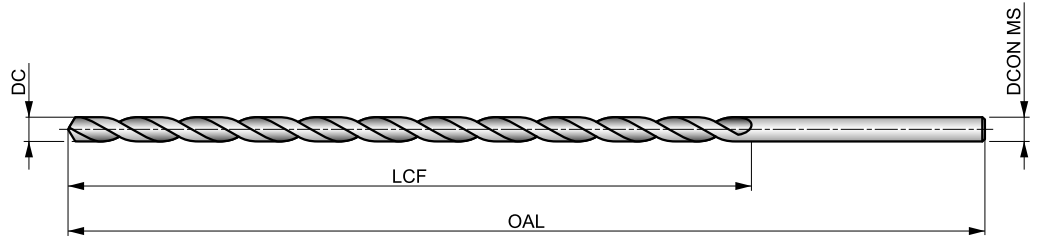

HSS	BS 328	10×D
118°	ST	
λ 20-35°	R	DC h8

Adéquation du groupe de matériaux de la pièce, valeurs de départ pour la vitesse de coupe (m/min) et code Alpha d'avance. Les tableaux d'avances par tour se trouvent à partir de la page 175.

P1.1 ■ 21 E	P1.2 ■ 24 E	P1.3 ■ 25 E	P2.1 ■ 18 E	P2.2 ■ 16 C	P2.3 ■ 14 A	P3.1 ■ 9 C	P3.2 ■ 7 C	P3.3 ■ 6 A	P4.1 ■ 5 C	P4.2 ■ 4 A	P4.3 ■ 4 A	M1.1 ■ 12 C	M1.2 ■ 10 C
M2.1 ■ 11 C	M2.2 ■ 9 C	M3.1 ■ 5 E	M3.2 ■ 4 E	M3.3 ■ 4 E	M4.1 ■ 8 A	K1.1 ■ 22 G	K1.2 ■ 16 D	K1.3 ■ 12 D	K2.1 ■ 16 C	K2.2 ■ 13 C	K2.3 ■ 10 C	K3.1 ■ 14 C	K3.2 ■ 11 C
K3.3 ■ 9 C	K4.1 ■ 13 C	K4.2 ■ 10 C	K4.3 ■ 7 C	K4.4 ■ 6 C	K4.5 ■ 5 C	K5.1 ■ 15 C	K5.2 ■ 11 C	K5.3 ■ 9 C	N1.1 ■ 24 H	N1.2 ■ 18 H	N1.3 ■ 12 G	N2.1 ■ 34 F	N2.2 ■ 30 F
N2.3 ■ 22 F	N3.1 ■ 56 F	N3.2 ■ 33 G	N3.3 ■ 17 D	N4.1 ■ 30 H	N4.2 ■ 26 F	N4.3 ■ 10 D	S1.1 ■ 11 D	S1.2 ■ 9 B	S1.3 ■ 5 A	S2.1 ■ 5 C	S2.2 ■ 4 A	S3.1 ■ 4 C	S3.2 ■ 3 A
S4.1 ■ 3 C	S4.2 ■ 2 A												

DC <= 2.2mm; 5/64" Brillant.

Produit	DC	DC	DC	LCF	OAL	DCON MS
	(inch)	(mm)	(inch)			
A1251.4X160	-	1.40	0.0551	100.0	160.0	1.40
A1251.5X125	-	1.50	0.0591	80.0	125.0	1.50
A1251.5X160	-	1.50	0.0591	100.0	160.0	1.50
A1251/16X125	1/16	1.59	0.0625	80.0	125.0	1.59
A1251/16X160	1/16	1.59	0.0625	100.0	160.0	1.59
A1251.8X160	-	1.80	0.0709	100.0	160.0	1.80
A1255/64X125	5/64	1.98	0.0781	80.0	125.0	1.98
A1255/64X160	5/64	1.98	0.0781	100.0	160.0	1.98
A1252.0X125	-	2.00	0.0787	80.0	125.0	2.00
A1252.0X160	-	2.00	0.0787	100.0	160.0	2.00
A1252.2X160	-	2.20	0.0866	100.0	160.0	2.20
A1253/32X125	3/32	2.38	0.0938	80.0	125.0	2.38
A1253/32X160	3/32	2.38	0.0938	100.0	160.0	2.38
A1252.5X125	-	2.50	0.0984	80.0	125.0	2.50
A1252.5X160	-	2.50	0.0984	100.0	160.0	2.50
A1257/64X125	7/64	2.78	0.1094	80.0	125.0	2.78
A1257/64X160	7/64	2.78	0.1094	100.0	160.0	2.78
A1253.0X160	-	3.00	0.1181	100.0	160.0	3.00
A1253.0X200	-	3.00	0.1181	150.0	200.0	3.00
A1253.0X250	-	3.00	0.1181	200.0	250.0	3.00
A1251/8X160	1/8	3.18	0.1252	100.0	160.0	3.18
A1251/8X200	1/8	3.18	0.1252	150.0	200.0	3.18
A1251/8X250	1/8	3.18	0.1252	200.0	250.0	3.18
A1251/8X315	1/8	3.18	0.1252	250.0	310.0	3.18
A1253.3X160	-	3.30	0.1299	100.0	160.0	3.30
A1253.5X160	-	3.50	0.1378	100.0	160.0	3.50

Produit	DC	DC	DC	LCF	OAL	DCON MS
	(inch)	(mm)	(inch)			
A1253.5X200	-	3.50	0.1378	150.0	200.0	3.50
A1253.5X250	-	3.50	0.1378	200.0	250.0	3.50
A1259/64X160	9/64	3.57	0.1406	100.0	160.0	3.57
A1259/64X200	9/64	3.57	0.1406	150.0	200.0	3.57
A1259/64X315	9/64	3.57	0.1406	250.0	310.0	3.57
A1255/32X160	5/32	3.97	0.1563	100.0	160.0	3.97
A1255/32X200	5/32	3.97	0.1563	150.0	200.0	3.97
A1255/32X250	5/32	3.97	0.1563	200.0	250.0	3.97
A1255/32X315	5/32	3.97	0.1563	250.0	310.0	3.97
A1254.0X160	-	4.00	0.1575	100.0	160.0	4.00
A1254.0X200	-	4.00	0.1575	150.0	200.0	4.00
A1254.0X250	-	4.00	0.1575	200.0	250.0	4.00
A1254.0X315	-	4.00	0.1575	250.0	310.0	4.00
A12511/64X160	11/64	4.37	0.1719	100.0	160.0	4.37
A12511/64X200	11/64	4.37	0.1719	150.0	200.0	4.37
A12511/64X315	11/64	4.37	0.1719	250.0	310.0	4.37
A1254.5X160	-	4.50	0.1772	100.0	160.0	4.50
A1254.5X200	-	4.50	0.1772	150.0	200.0	4.50
A1254.5X250	-	4.50	0.1772	200.0	250.0	4.50
A1254.5X315	-	4.50	0.1772	250.0	310.0	4.50
A1253/16X160	3/16	4.76	0.1875	100.0	160.0	4.76
A1253/16X200	3/16	4.76	0.1875	150.0	200.0	4.76
A1253/16X250	3/16	4.76	0.1875	200.0	250.0	4.76
A1253/16X315	3/16	4.76	0.1875	250.0	310.0	4.76
A1253/16X400	3/16	4.76	0.1875	300.0	400.0	4.76
A1255.0X160	-	5.00	0.1969	100.0	160.0	5.00



A976



Foret extra-long PFX en HSS-E (5% cobalt) (DIN 1869 série 1), finition brillante

Foret recommandé pour le perçage de trous très profonds ou pour les applications où une très longue portée est nécessaire. Les goujures paraboliques spécialement conçues éliminent le besoin de percer des trous profonds par petites étapes (débouillage). Pointe à 130°. Le centrage avec un foret PFX court 3xD est recommandé (pour garder la même tolérance sur DC). Convient pour le perçage de nombreux matériaux.

PFX

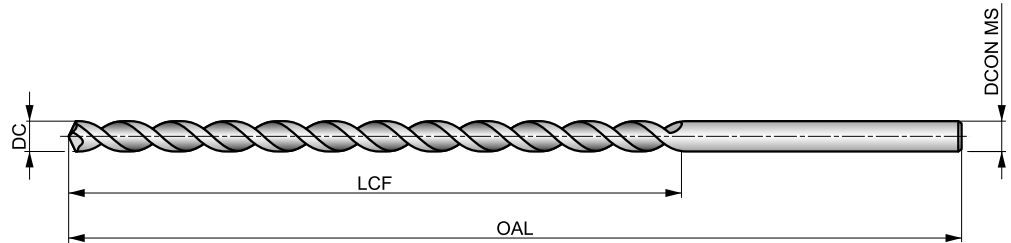

HSS-E	DIN 1869-1	15×D
130°	Bright	
λ>35°	R	DC h8

Adéquation du groupe de matériaux de la pièce, valeurs de départ pour la vitesse de coupe (m/min) et code Alpha d'avance. Les tableaux d'avances par tour se trouvent à partir de la page 175.

P1.1 ▣29 C	P1.2 ▣33 C	P1.3 ▣34 C	P2.1 ▣25 C	P2.2 ▣22 C	P2.3 ▣19 A	P3.1 ▣18 C	P3.2 ▣14 C	P3.3 ▣12 A	P4.1 ▣11 C	P4.2 ▣9 A	P4.3 ▣7 A	M1.1 ▣16 B	M1.2 ▣14 B
M2.1 ▣15 B	M2.2 ▣12 B	M3.1 ▣8 C	M3.2 ▣7 C	M3.3 ▣6 C	M4.1 ▣8 A	K2.1 ▣20 C	K2.2 ▣16 C	K2.3 ▣13 A	K3.1 ▣17 C	K3.2 ▣13 C	K3.3 ▣11 A	K4.1 ▣16 C	K4.2 ▣12 C
K4.3 ▣9 A	K4.4 ▣8 A	K4.5 ▣6 A	K5.1 ▣18 C	K5.2 ▣14 C	K5.3 ▣11 A	N3.1 ▣30 D	S1.1 ▣15 C	S1.2 ▣11 A	S1.3 ▣5 A				

Produit	DC	DC	DC	LCF	OAL	DCON MS
	(inch)	(mm)	(inch)	(mm)	(mm)	(mm)
A9761.5	–	1.50	0.0591	75.0	115.0	1.50
A9762.0X125	–	2.00	0.0787	85.0	125.0	2.00
A9762.1X125	–	2.10	0.0827	85.0	125.0	2.10
A9762.2X135	–	2.20	0.0866	90.0	135.0	2.20
A9762.3X135	–	2.30	0.0906	90.0	135.0	2.30
A9762.4X140	–	2.40	0.0945	95.0	140.0	2.40
A9762.5X140	–	2.50	0.0984	95.0	140.0	2.50
A9762.6X140	–	2.60	0.1024	95.0	140.0	2.60
A9762.7X150	–	2.70	0.1063	100.0	150.0	2.70
A9762.8X150	–	2.80	0.1102	100.0	150.0	2.80
A9762.9X150	–	2.90	0.1142	100.0	150.0	2.90
A9763.0X150	–	3.00	0.1181	100.0	150.0	3.00
A9763.1X155	–	3.10	0.1220	105.0	155.0	3.10
A9761/8	1/8	3.18	0.1252	105.0	155.0	3.18
A9763.2X155	–	3.20	0.1260	105.0	155.0	3.20
A9763.3X155	–	3.30	0.1299	105.0	155.0	3.30
A9763.4X165	–	3.40	0.1339	115.0	165.0	3.40
A9763.5X165	–	3.50	0.1378	115.0	165.0	3.50
A9763.6X165	–	3.60	0.1417	115.0	165.0	3.60
A9763.7X165	–	3.70	0.1457	115.0	165.0	3.70
A9763.8X175	–	3.80	0.1496	120.0	175.0	3.80
A9763.9X175	–	3.90	0.1535	120.0	175.0	3.90
A9765/32	5/32	3.97	0.1563	120.0	175.0	3.97
A9764.0X175	–	4.00	0.1575	120.0	175.0	4.00
A9764.1X175	–	4.10	0.1614	120.0	175.0	4.10
A9764.2X175	–	4.20	0.1654	120.0	175.0	4.20
A9764.3X185	–	4.30	0.1693	125.0	185.0	4.30
A9764.4X185	–	4.40	0.1732	125.0	185.0	4.40

Produit	DC	DC	DC	LCF	OAL	DCON MS
	(inch)	(mm)	(inch)	(mm)	(mm)	(mm)
A9764.5X185	–	4.50	0.1772	125.0	185.0	4.50
A9764.6X185	–	4.60	0.1811	125.0	185.0	4.60
A9764.7X185	–	4.70	0.1850	125.0	185.0	4.70
A9763/16	3/16	4.76	0.1875	135.0	195.0	4.76
A9764.8X195	–	4.80	0.1890	135.0	195.0	4.80
A9764.9X195	–	4.90	0.1929	135.0	195.0	4.90
A9765.0X195	–	5.00	0.1969	135.0	195.0	5.00
A9765.1X195	–	5.10	0.2008	135.0	195.0	5.10
A9765.2X195	–	5.20	0.2047	135.0	195.0	5.20
A9765.3X195	–	5.30	0.2087	135.0	195.0	5.30
A9765.4X205	–	5.40	0.2126	140.0	205.0	5.40
A9765.5X205	–	5.50	0.2165	140.0	205.0	5.50
A9765.6X205	–	5.60	0.2205	140.0	205.0	5.60
A9765.7X205	–	5.70	0.2244	140.0	205.0	5.70
A9765.8X205	–	5.80	0.2283	140.0	205.0	5.80
A9765.9X205	–	5.90	0.2323	140.0	205.0	5.90
A9766.0X205	–	6.00	0.2362	140.0	205.0	6.00
A9766.1X215	–	6.10	0.2402	150.0	215.0	6.10
A9766.2X215	–	6.20	0.2441	150.0	215.0	6.20
A9766.3X215	–	6.30	0.2480	150.0	215.0	6.30
A9761/4	1/4	6.35	0.2500	150.0	215.0	6.35
A9766.4X215	–	6.40	0.2520	150.0	215.0	6.40
A9766.5X215	–	6.50	0.2559	150.0	215.0	6.50
A9766.6X215	–	6.60	0.2598	150.0	215.0	6.60
A9766.7X215	–	6.70	0.2638	150.0	215.0	6.70
A9766.8X225	–	6.80	0.2677	155.0	225.0	6.80
A9766.9X225	–	6.90	0.2717	155.0	225.0	6.90
A9767.0X225	–	7.00	0.2756	155.0	225.0	7.00



Produit	DC	DC	DC	LCF	OAL	DCON MS
	(inch)	(mm)	(inch)	(mm)	(mm)	(mm)
A9767.5X225	–	7.50	0.2953	155.0	225.0	7.50
A9765/16	5/16	7.94	0.3125	165.0	240.0	7.94
A9768.0X240	–	8.00	0.3150	165.0	240.0	8.00
A9768.5X240	–	8.50	0.3346	165.0	240.0	8.50
A97611/32	11/32	8.73	0.3438	175.0	250.0	8.73
A9769.0X250	–	9.00	0.3543	175.0	250.0	9.00
A9769.5X250	–	9.50	0.3740	175.0	250.0	9.50
A9763/8	3/8	9.52	0.3750	185.0	265.0	9.52
A97610.0X265	–	10.00	0.3937	185.0	265.0	10.00

¹⁾ Standard Dormer.

Produit	DC	DC	DC	LCF	OAL	DCON MS
	(inch)	(mm)	(inch)	(mm)	(mm)	(mm)
A97610.5	–	10.50	0.4134	185.0	265.0	10.50
A97611.0	–	11.00	0.4331	195.0	280.0	11.00
A9767/16	7/16	11.11	0.4375	195.0	280.0	11.11
A97611.5	–	11.50	0.4528	195.0	280.0	11.50
A97612.0	–	12.00	0.4724	205.0	295.0	12.00
A97612.5	–	12.50	0.4921	205.0	295.0	12.50
A9761/2	1/2	12.70	0.5000	205.0	295.0	12.70
A97613.0	–	13.00	0.5118	205.0	295.0	13.00
A97614.0 ¹⁾	–	14.00	0.5512	215.0	310.0	14.00



A977



Foret extra-long PFX en HSS-E (5% cobalt) (DIN 1869 série 2), finition brillante

Foret recommandé pour le perçage de trous très profonds et dans les applications où une très longue portée est nécessaire. Les goujures paraboliques spécialement conçues éliminent le besoin de percer des trous profonds par petites étapes (débouillage). Pointe à 130°. Le centrage avec un foret PFX court 3xD est recommandé (pour garder la même tolérance sur DC). Convient pour le perçage de nombreux matériaux.

PFX

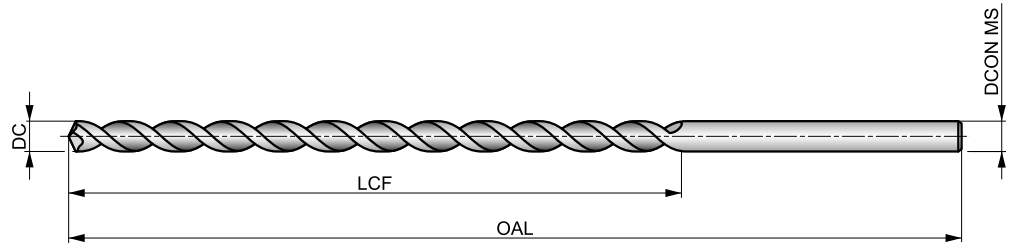

HSS-E	DIN 1869-2	20xD
130°	Bright	
$\lambda > 35^\circ$	R	DC h8

Adéquation du groupe de matériaux de la pièce, valeurs de départ pour la vitesse de coupe (m/min) et code Alpha d'avance. Les tableaux d'avances par tour se trouvent à partir de la page 175.

P1.1 ▣29 B	P1.2 ▣33 B	P1.3 ▣34 B	P2.1 ▣25 B	P2.2 ▣22 B	P2.3 ▣19 A	P3.1 ▣18 B	P3.2 ▣14 B	P3.3 ▣12 A	P4.1 ▣11 B	P4.2 ▣9 A	P4.3 ▣7 A	M1.1 ▣16 B	M1.2 ▣14 B
M2.1 ▣15 B	M2.2 ▣12 B	M3.1 ▣8 B	M3.2 ▣7 B	M3.3 ▣6 B	M4.1 ▣8 A	K2.1 ▣20 B	K2.2 ▣16 B	K2.3 ▣13 A	K3.1 ▣17 B	K3.2 ▣13 B	K3.3 ▣11 A	K4.1 ▣16 B	K4.2 ▣12 B
K4.3 ▣9 A	K4.4 ▣8 A	K4.5 ▣6 A	K5.1 ▣18 B	K5.2 ▣14 B	K5.3 ▣11 A	N3.1 ▣30 C	S1.1 ▣15 B	S1.2 ▣11 A	S1.3 ▣5 A				

Produit	DC	DC	DC	LCF	OAL	DCON MS
	(inch)	(mm)	(inch)	(mm)	(mm)	(mm)
A9771.5 ¹⁾	—	1.50	0.0591	100.0	150.0	1.50
A9771/16 ¹⁾	1/16	1.59	0.0625	100.0	150.0	1.59
A9772.0 ¹⁾	—	2.00	0.0787	110.0	160.0	2.00
A9773/32 ¹⁾	3/32	2.38	0.0938	115.0	170.0	2.38
A9773.0X190	—	3.00	0.1181	130.0	190.0	3.00
A9771/8	1/8	3.18	0.1250	135.0	200.0	3.18
A9773.5X210	—	3.50	0.1378	145.0	210.0	3.50
A9774.0X220	—	4.00	0.1575	150.0	220.0	4.00
A9774.5X235	—	4.50	0.1772	160.0	235.0	4.50
A9773/16	3/16	4.76	0.1875	170.0	245.0	4.76
A9775.0X245	—	5.00	0.1969	170.0	245.0	5.00
A9775.5X260	—	5.50	0.2165	180.0	260.0	5.50
A9776.0X260	—	6.00	0.2362	180.0	260.0	6.00
A9771/4	1/4	6.35	0.2500	190.0	275.0	6.35
A9776.5X275	—	6.50	0.2559	190.0	275.0	6.50

Produit	DC	DC	DC	LCF	OAL	DCON MS
	(inch)	(mm)	(inch)	(mm)	(mm)	(mm)
A9777.0X290	—	7.00	0.2756	200.0	290.0	7.00
A9777.5X290	—	7.50	0.2953	200.0	290.0	7.50
A9778.0X305	—	8.00	0.3150	210.0	305.0	8.00
A9778.5X305	—	8.50	0.3346	210.0	305.0	8.50
A97711/32	11/32	8.73	0.3438	220.0	320.0	8.73
A9779.0X320	—	9.00	0.3543	220.0	320.0	9.00
A9779.5X320	—	9.50	0.3740	220.0	320.0	9.50
A97710.0X340	—	10.00	0.3937	235.0	340.0	10.00
A97710.5	—	10.50	0.4134	235.0	340.0	10.50
A97711.0	—	11.00	0.4331	250.0	365.0	11.00
A97711.5	—	11.50	0.4528	250.0	365.0	11.50
A97712.0	—	12.00	0.4724	260.0	375.0	12.00
A97712.5	—	12.50	0.4921	260.0	375.0	12.50
A97713.0	—	13.00	0.5118	260.0	375.0	13.00
A97714.0 ¹⁾	—	14.00	0.5512	270.0	390.0	14.00

¹⁾ Standard Dormer.



A978



Foret extra-long PFX en HSS-E (5% cobalt) (DIN 1869-3), finition brillante

Foret recommandé pour les trous extra profonds et pour les applications nécessitant une plus grande portée. Les goujures paraboliques spécialement conçues éliminent le besoin de percer des trous profonds par petites étapes (débourrage). Pointe à 130°. Le centrage avec un foret PFX court 3xD est recommandé (pour garder la même tolérance sur DC). Convient pour le perçage de nombreux matériaux.

PFX

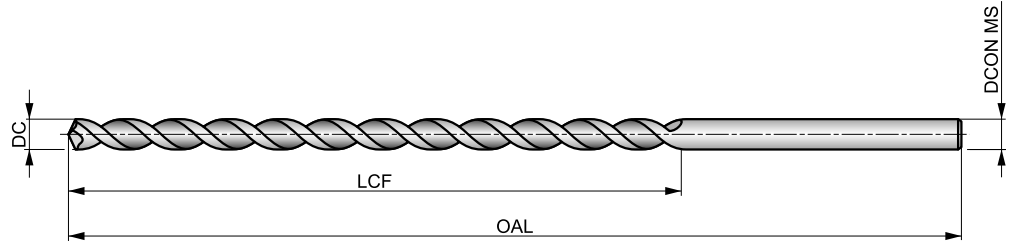

HSS-E	DIN 1869-3	25xD
130°	Bright	
$\lambda > 35^\circ$	R	DC h8

Adéquation du groupe de matériaux de la pièce, valeurs de départ pour la vitesse de coupe (m/min) et code Alpha d'avance. Les tableaux d'avances par tour se trouvent à partir de la page 175.

P1.1 ▣29 A	P1.2 ▣33 A	P1.3 ▣34 A	P2.1 ▣25 A	P2.2 ▣22 A	P2.3 ▣19 A	P3.1 ▣18 A	P3.2 ▣14 A	P3.3 ▣12 A	P4.1 ▣11 A	P4.2 ▣9 A	P4.3 ▣7 A	M1.1 ▣16 A	M1.2 ▣14 A
M2.1 ▣15 A	M2.2 ▣12 A	M3.1 ▣8 A	M3.2 ▣17 A	M3.3 ▣6 A	M4.1 ▣8 A	K2.1 ▣20 A	K2.2 ▣16 A	K2.3 ▣13 A	K3.1 ▣17 A	K3.2 ▣13 A	K3.3 ▣11 A	K4.1 ▣16 A	K4.2 ▣12 A
K4.3 ▣9 A	K4.4 ▣8 A	K4.5 ▣6 A	K5.1 ▣18 A	K5.2 ▣14 A	K5.3 ▣11 A	N3.1 ▣30 B	S1.1 ▣15 A	S1.2 ▣11 A	S1.3 ▣5 A				

Produit	DC	DC	DC	LCF	OAL	DCON MS
	(inch)	(mm)	(inch)	(mm)	(mm)	(mm)
A9783.0 ¹⁾	–	3.00	0.1181	160.0	240.0	3.00
A9783.5X265	–	3.50	0.1378	180.0	265.0	3.50
A9784.0X280	–	4.00	0.1575	190.0	280.0	4.00
A9784.5X295	–	4.50	0.1772	200.0	295.0	4.50
A9785.0X315	–	5.00	0.1969	210.0	315.0	5.00
A9785.5X330	–	5.50	0.2165	225.0	330.0	5.50
A9786.0X330	–	6.00	0.2362	225.0	330.0	6.00
A9781/4	1/4	6.35	0.2500	235.0	350.0	6.35
A9786.5X350	–	6.50	0.2559	235.0	350.0	6.50
A9787.0X370	–	7.00	0.2756	250.0	370.0	7.00
A9787.5X370	–	7.50	0.2953	250.0	370.0	7.50
A9788.0X390	–	8.00	0.3150	265.0	390.0	8.00
A9788.5X390	–	8.50	0.3346	265.0	390.0	8.50
A9789.0X410	–	9.00	0.3543	280.0	410.0	9.00
A9789.5X410	–	9.50	0.3740	280.0	410.0	9.50
A97810.0X430	–	10.00	0.3937	295.0	430.0	10.00

¹⁾ Standard Dormer.



A130



Foret à queue cône morse en HSS, finition avec traitement vapeur

Foret polyvalent pour les grands diamètres - jusqu'à 50,80 mm (2 pouces). Sa queue conique offre une meilleure prise pour le tenir dans la machine. Sa pointe conventionnelle à 118° assure la résistance et facilite le réaffûtage. La finition avec traitement vapeur retient le liquide de coupe et empêche le collage des copeaux sur l'outil. Convient pour le perçage de nombreux matériaux.

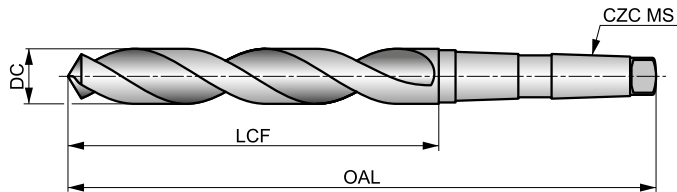

HSS	DIN 345	4xD
118°	ST	
λ 20-35°	R	DC h8

Adéquation du groupe de matériaux de la pièce, valeurs de départ pour la vitesse de coupe (m/min) et code Alpha d'avance. Les tableaux d'avances par tour se trouvent à partir de la page 175.

P1.1 ■ 33 I	P1.2 ■ 37 I	P1.3 ■ 38 I	P2.1 ■ 28 I	P2.2 ■ 25 F	P2.3 ■ 22 E	P3.1 ■ 18 F	P3.2 ■ 14 F	P3.3 ■ 12 E	P4.1 ■ 11 F	P4.2 ■ 9 E	P4.3 ■ 7 D	M1.1 ■ 21 E	M1.2 ■ 17 E
M2.1 ■ 18 E	M2.2 ■ 15 E	M3.1 ■ 10 G	M3.2 ■ 9 G	M3.3 ■ 8 G	M4.1 ■ 10 C	K1.1 ■ 30 I	K1.2 ■ 22 E	K1.3 ■ 17 E	K2.1 ■ 25 E	K2.2 ■ 20 E	K2.3 ■ 16 E	K3.1 ■ 22 E	K3.2 ■ 17 E
K3.3 ■ 13 E	K4.1 ■ 20 E	K4.2 ■ 15 E	K4.3 ■ 11 E	K4.4 ■ 10 E	K4.5 ■ 8 E	K5.1 ■ 23 E	K5.2 ■ 17 E	K5.3 ■ 13 E	N1.1 ■ 26 J	N1.2 ■ 20 J	N1.3 ■ 13 I	N2.1 ■ 43 H	N2.2 ■ 39 H
N2.3 ■ 28 H	N3.1 ■ 59 H	N3.2 ■ 35 I	N3.3 ■ 18 F	N4.1 ■ 30 K	N4.2 ■ 28 J	N4.3 ■ 14 H	S1.1 ■ 23 F	S1.2 ■ 13 D	S1.3 ■ 7 B	S2.1 ■ 9 E	S2.2 ■ 6 A	S3.1 ■ 7 E	S3.2 ■ 4 A
S4.1 ■ 5 E	S4.2 ■ 3 A												

DC > 14mm avec pointe amincie.

Produit	DC	DC	DC	LCF	OAL	CZC MS
	(inch)	(mm)	(inch)	(mm)	(mm)	
A1303.0	—	3.00	0.1181	33.0	114.0	MK 1
A1301/8	1/8	3.18	0.1252	36.0	117.0	MK 1
A1303.2	—	3.20	0.1260	36.0	117.0	MK 1
A1303.25	—	3.25	0.1280	36.0	117.0	MK 1
A1303.3	—	3.30	0.1299	36.0	117.0	MK 1
A1303.5	—	3.50	0.1378	39.0	120.0	MK 1
A1309/64	9/64	3.57	0.1406	39.0	120.0	MK 1
A1303.75	—	3.75	0.1476	39.0	120.0	MK 1
A1305/32	5/32	3.97	0.1563	43.0	124.0	MK 1
A1304.0	—	4.00	0.1575	43.0	124.0	MK 1
A1304.1	—	4.10	0.1614	43.0	124.0	MK 1
A1304.2	—	4.20	0.1654	43.0	124.0	MK 1
A1304.25	—	4.25	0.1673	43.0	124.0	MK 1
A13011/64	11/64	4.37	0.1719	47.0	128.0	MK 1
A1304.5	—	4.50	0.1772	47.0	128.0	MK 1
A1304.75	—	4.75	0.1870	52.0	128.0	MK 1
A1303/16	3/16	4.76	0.1875	52.0	133.0	MK 1
A1304.8	—	4.80	0.1890	52.0	133.0	MK 1
A1304.9	—	4.90	0.1929	52.0	133.0	MK 1
A1305.0	—	5.00	0.1969	52.0	133.0	MK 1
A1305.1	—	5.10	0.2008	52.0	133.0	MK 1
A13013/64	13/64	5.16	0.2031	52.0	133.0	MK 1
A1305.2	—	5.20	0.2047	52.0	133.0	MK 1



Produit	DC	DC	DC	LCF	OAL	CZC MS
	(inch)	(mm)	(inch)	(mm)	(mm)	
A1305.25	–	5.25	0.2067	52.0	133.0	MK 1
A1305.4	–	5.40	0.2126	57.0	138.0	MK 1
A1305.5	–	5.50	0.2165	57.0	138.0	MK 1
A1307/32	7/32	5.56	0.2188	57.0	138.0	MK 1
A1305.7	–	5.70	0.2244	57.0	138.0	MK 1
A1305.75	–	5.75	0.2264	57.0	138.0	MK 1
A1305.8	–	5.80	0.2283	57.0	138.0	MK 1
A1305.9	–	5.90	0.2323	57.0	138.0	MK 1
A13015/64	15/64	5.95	0.2344	57.0	138.0	MK 1
A1306.0	–	6.00	0.2362	57.0	138.0	MK 1
A1306.1	–	6.10	0.2402	63.0	144.0	MK 1
A1306.2	–	6.20	0.2441	63.0	144.0	MK 1
A1306.25	–	6.25	0.2461	63.0	144.0	MK 1
A1306.3	–	6.30	0.2480	63.0	144.0	MK 1
A1301/4	1/4	6.35	0.2500	63.0	144.0	MK 1
A1306.4	–	6.40	0.2520	63.0	144.0	MK 1
A1306.5	–	6.50	0.2559	63.0	144.0	MK 1
A1306.6	–	6.60	0.2598	63.0	144.0	MK 1
A1306.7	–	6.70	0.2638	63.0	144.0	MK 1
A13017/64	17/64	6.75	0.2656	69.0	150.0	MK 1
A1306.75	–	6.75	0.2657	69.0	150.0	MK 1
A1306.8	–	6.80	0.2677	69.0	150.0	MK 1
A1306.9	–	6.90	0.2717	69.0	150.0	MK 1
A1307.0	–	7.00	0.2756	69.0	150.0	MK 1
A1309/32	9/32	7.14	0.2813	69.0	150.0	MK 1
A1307.2	–	7.20	0.2835	69.0	150.0	MK 1
A1307.25	–	7.25	0.2854	69.0	150.0	MK 1
A1307.3	–	7.30	0.2874	69.0	150.0	MK 1
A1307.4	–	7.40	0.2913	69.0	150.0	MK 1
A1307.5	–	7.50	0.2953	69.0	150.0	MK 1
A13019/64	19/64	7.54	0.2969	75.0	156.0	MK 1
A1307.7	–	7.70	0.3031	75.0	156.0	MK 1
A1307.75	–	7.75	0.3051	75.0	156.0	MK 1
A1307.8	–	7.80	0.3071	75.0	156.0	MK 1
A1307.9	–	7.90	0.3110	75.0	156.0	MK 1
A1305/16	5/16	7.94	0.3125	75.0	156.0	MK 1
A1308.0	–	8.00	0.3150	75.0	156.0	MK 1
A1308.1	–	8.10	0.3189	75.0	156.0	MK 1
A1308.2	–	8.20	0.3228	75.0	156.0	MK 1
A1308.25	–	8.25	0.3248	75.0	156.0	MK 1
A1308.3	–	8.30	0.3268	75.0	156.0	MK 1
A13021/64	21/64	8.33	0.3281	75.0	156.0	MK 1
A1308.4	–	8.40	0.3307	75.0	156.0	MK 1
A1308.5	–	8.50	0.3346	75.0	156.0	MK 1
A1308.6	–	8.60	0.3386	81.0	162.0	MK 1
A1308.7	–	8.70	0.3425	81.0	162.0	MK 1
A13011/32	11/32	8.73	0.3438	81.0	162.0	MK 1
A1308.75	–	8.75	0.3445	81.0	162.0	MK 1
A1308.8	–	8.80	0.3465	81.0	162.0	MK 1
A1308.9	–	8.90	0.3504	81.0	162.0	MK 1
A1309.0	–	9.00	0.3543	81.0	162.0	MK 1
A1309.1	–	9.10	0.3583	81.0	162.0	MK 1
A13023/64	23/64	9.13	0.3594	81.0	162.0	MK 1
A1309.2	–	9.20	0.3622	81.0	162.0	MK 1
A1309.25	–	9.25	0.3642	81.0	162.0	MK 1
A1309.3	–	9.30	0.3661	81.0	162.0	MK 1
A1309.5	–	9.50	0.3740	81.0	162.0	MK 1
A1303/8	3/8	9.52	0.3750	87.0	168.0	MK 1
A1309.6	–	9.60	0.3780	87.0	168.0	MK 1
A1309.7	–	9.70	0.3819	87.0	168.0	MK 1
A1309.75	–	9.75	0.3839	87.0	168.0	MK 1
A1309.8	–	9.80	0.3858	87.0	168.0	MK 1



Produit	DC	DC	DC	LCF	OAL	CZC MS
	(inch)	(mm)	(inch)	(mm)	(mm)	
A1309.9	–	9.90	0.3898	87.0	168.0	MK 1
A13025/64	25/64	9.92	0.3906	87.0	168.0	MK 1
A13010.0	–	10.00	0.3937	87.0	168.0	MK 1
A13010.1	–	10.10	0.3976	87.0	168.0	MK 1
A13010.2	–	10.20	0.4016	87.0	168.0	MK 1
A13010.25	–	10.25	0.4035	87.0	168.0	MK 1
A13010.3	–	10.30	0.4055	87.0	168.0	MK 1
A13013/32	13/32	10.32	0.4063	87.0	168.0	MK 1
A13010.5	–	10.50	0.4134	87.0	168.0	MK 1
A13027/64	27/64	10.72	0.4219	94.0	175.0	MK 1
A13010.75	–	10.75	0.4232	94.0	175.0	MK 1
A13010.8	–	10.80	0.4252	94.0	175.0	MK 1
A13010.9	–	10.90	0.4291	94.0	175.0	MK 1
A13011.0	–	11.00	0.4331	94.0	175.0	MK 1
A13011.1	–	11.10	0.4370	94.0	175.0	MK 1
A1307/16	7/16	11.11	0.4375	94.0	175.0	MK 1
A13011.2	–	11.20	0.4409	94.0	175.0	MK 1
A13011.25	–	11.25	0.4429	94.0	175.0	MK 1
A13011.3	–	11.30	0.4449	94.0	175.0	MK 1
A13011.4	–	11.40	0.4488	94.0	175.0	MK 1
A13011.5	–	11.50	0.4528	94.0	175.0	MK 1
A13029/64	29/64	11.51	0.4531	94.0	175.0	MK 1
A13011.6	–	11.60	0.4567	94.0	175.0	MK 1
A13011.7	–	11.70	0.4606	94.0	175.0	MK 1
A13011.75	–	11.75	0.4626	94.0	175.0	MK 1
A13011.8	–	11.80	0.4646	94.0	175.0	MK 1
A13011.9	–	11.90	0.4685	101.0	182.0	MK 1
A13015/32	15/32	11.91	0.4688	101.0	182.0	MK 1
A13012.0	–	12.00	0.4724	101.0	182.0	MK 1
A13012.1	–	12.10	0.4764	101.0	182.0	MK 1
A13012.2	–	12.20	0.4803	101.0	182.0	MK 1
A13012.25	–	12.25	0.4823	101.0	182.0	MK 1
A13031/64	31/64	12.30	0.4844	101.0	182.0	MK 1
A13012.3	–	12.30	0.4843	101.0	182.0	MK 1
A13012.4	–	12.40	0.4882	101.0	182.0	MK 1
A13012.5	–	12.50	0.4921	101.0	182.0	MK 1
A13012.6	–	12.60	0.4961	101.0	182.0	MK 1
A13012.7	–	12.70	0.5000	101.0	182.0	MK 1
A1301/2	1/2	12.70	0.5000	101.0	182.0	MK 1
A13012.75	–	12.75	0.5020	101.0	182.0	MK 1
A13012.8	–	12.80	0.5039	101.0	182.0	MK 1
A13012.9	–	12.90	0.5079	101.0	182.0	MK 1
A13013.0	–	13.00	0.5118	101.0	182.0	MK 1
A13033/64	33/64	13.10	0.5156	101.0	182.0	MK 1
A13013.2	–	13.20	0.5197	101.0	182.0	MK 1
A13013.25	–	13.25	0.5217	108.0	189.0	MK 1
A13017/32	17/32	13.49	0.5313	108.0	189.0	MK 1
A13013.5	–	13.50	0.5315	108.0	189.0	MK 1
A13013.6	–	13.60	0.5354	108.0	189.0	MK 1
A13013.7	–	13.70	0.5394	108.0	189.0	MK 1
A13013.75	–	13.75	0.5413	108.0	189.0	MK 1
A13013.8	–	13.80	0.5433	108.0	189.0	MK 1
A13035/64	35/64	13.89	0.5469	108.0	189.0	MK 1
A13013.9	–	13.90	0.5472	108.0	189.0	MK 1
A13014.0	–	14.00	0.5512	108.0	189.0	MK 1
A13014.1	–	14.10	0.5551	114.0	212.0	MK 2
A13014.2	–	14.20	0.5591	114.0	212.0	MK 2
A13014.25	–	14.25	0.5610	114.0	212.0	MK 2
A1309/16	9/16	14.29	0.5625	114.0	212.0	MK 2
A13014.3	–	14.30	0.5630	114.0	212.0	MK 2
A13014.4	–	14.40	0.5669	114.0	212.0	MK 2
A13014.5	–	14.50	0.5709	114.0	212.0	MK 2



Produit	DC	DC	DC	LCF	OAL	CZC MS
	(inch)	(mm)	(inch)	(mm)	(mm)	
A13014.6	–	14.60	0.5748	114.0	212.0	MK 2
A13037/64	37/64	14.68	0.5781	114.0	212.0	MK 2
A13014.7	–	14.70	0.5787	114.0	212.0	MK 2
A13014.75	–	14.75	0.5807	114.0	212.0	MK 2
A13014.8	–	14.80	0.5827	114.0	212.0	MK 2
A13014.9	–	14.90	0.5866	114.0	212.0	MK 2
A13015.0	–	15.00	0.5906	114.0	212.0	MK 2
A13019/32	19/32	15.08	0.5938	120.0	218.0	MK 2
A13015.1	–	15.10	0.5945	120.0	218.0	MK 2
A13015.2	–	15.20	0.5984	120.0	218.0	MK 2
A13015.25	–	15.25	0.6004	120.0	218.0	MK 2
A13039/64	39/64	15.48	0.6094	120.0	218.0	MK 2
A13015.5	–	15.50	0.6102	120.0	218.0	MK 2
A13015.7	–	15.70	0.6181	120.0	218.0	MK 2
A13015.75	–	15.75	0.6201	120.0	218.0	MK 2
A13015.8	–	15.80	0.6220	120.0	218.0	MK 2
A1305/8	5/8	15.88	0.6250	120.0	218.0	MK 2
A13015.9	–	15.90	0.6260	120.0	218.0	MK 2
A13016.0	–	16.00	0.6299	120.0	218.0	MK 2
A13016.1	–	16.10	0.6339	125.0	223.0	MK 2
A13016.2	–	16.20	0.6378	125.0	223.0	MK 2
A13016.25	–	16.25	0.6398	125.0	223.0	MK 2
A13041/64	41/64	16.27	0.6406	125.0	223.0	MK 2
A13016.5	–	16.50	0.6496	125.0	223.0	MK 2
A13021/32	21/32	16.67	0.6563	125.0	223.0	MK 2
A13016.75	–	16.75	0.6594	125.0	223.0	MK 2
A13017.0	–	17.00	0.6693	125.0	223.0	MK 2
A13043/64	43/64	17.07	0.6719	130.0	228.0	MK 2
A13017.25	–	17.25	0.6791	130.0	228.0	MK 2
A13011/16	11/16	17.46	0.6875	130.0	228.0	MK 2
A13017.5	–	17.50	0.6890	130.0	228.0	MK 2
A13017.75	–	17.75	0.6988	130.0	228.0	MK 2
A13045/64	45/64	17.86	0.7031	130.0	228.0	MK 2
A13018.0	–	18.00	0.7087	130.0	228.0	MK 2
A13018.25	–	18.25	0.7185	135.0	233.0	MK 2
A13023/32	23/32	18.26	0.7188	135.0	233.0	MK 2
A13018.5	–	18.50	0.7283	135.0	233.0	MK 2
A13047/64	47/64	18.65	0.7344	135.0	233.0	MK 2
A13018.75	–	18.75	0.7382	135.0	233.0	MK 2
A13019.0	–	19.00	0.7480	135.0	233.0	MK 2
A1303/4	3/4	19.05	0.7500	140.0	238.0	MK 2
A13019.25	–	19.25	0.7579	140.0	238.0	MK 2
A13049/64	49/64	19.45	0.7656	140.0	238.0	MK 2
A13019.5	–	19.50	0.7677	140.0	238.0	MK 2
A13019.75	–	19.75	0.7776	140.0	238.0	MK 2
A13025/32	25/32	19.84	0.7813	140.0	238.0	MK 2
A13020.0	–	20.00	0.7874	140.0	238.0	MK 2
A13051/64	51/64	20.24	0.7969	145.0	243.0	MK 2
A13020.25	–	20.25	0.7972	145.0	243.0	MK 2
A13020.4	–	20.40	0.8031	145.0	243.0	MK 2
A13020.5	–	20.50	0.8071	145.0	243.0	MK 2
A13013/16	13/16	20.64	0.8125	145.0	243.0	MK 2
A13020.75	–	20.75	0.8169	145.0	243.0	MK 2
A13021.0	–	21.00	0.8268	145.0	243.0	MK 2
A13053/64	53/64	21.03	0.8281	145.0	243.0	MK 2
A13021.25	–	21.25	0.8366	150.0	248.0	MK 2
A13027/32	27/32	21.43	0.8437	150.0	248.0	MK 2
A13021.5	–	21.50	0.8465	150.0	248.0	MK 2
A13021.75	–	21.75	0.8563	150.0	248.0	MK 2
A13055/64	55/64	21.83	0.8594	150.0	248.0	MK 2
A13022.0	–	22.00	0.8661	150.0	248.0	MK 2
A1307/8	7/8	22.22	0.8750	150.0	248.0	MK 2



Produit	DC	DC	DC	LCF	OAL	CZC MS
	(inch)	(mm)	(inch)	(mm)	(mm)	
A13022.25	–	22.25	0.8760	150.0	248.0	MK 2
A13022.5	–	22.50	0.8858	155.0	253.0	MK 2
A13057/64	57/64	22.62	0.8906	155.0	253.0	MK 2
A13022.75	–	22.75	0.8957	155.0	253.0	MK 2
A13023.0	–	23.00	0.9055	155.0	253.0	MK 2
A13029/32	29/32	23.02	0.9063	155.0	253.0	MK 2
A13023.25	–	23.25	0.9154	155.0	276.0	MK 3
A13059/64	59/64	23.42	0.9219	155.0	276.0	MK 3
A13023.5	–	23.50	0.9252	155.0	276.0	MK 3
A13023.75	–	23.75	0.9350	160.0	281.0	MK 3
A13015/16	15/16	23.81	0.9375	160.0	281.0	MK 3
A13024.0	–	24.00	0.9449	160.0	281.0	MK 3
A13061/64	61/64	24.21	0.9531	160.0	281.0	MK 3
A13024.25	–	24.25	0.9547	160.0	281.0	MK 3
A13024.5	–	24.50	0.9646	160.0	281.0	MK 3
A13031/32	31/32	24.61	0.9688	160.0	281.0	MK 3
A13024.75	–	24.75	0.9744	160.0	281.0	MK 3
A13025.0	–	25.00	0.9843	160.0	281.0	MK 3
A13063/64	63/64	25.00	0.9844	160.0	286.0	MK 3
A13025.25	–	25.25	0.9941	165.0	286.0	MK 3
A1301	1"	25.40	1.0000	165.0	286.0	MK 3
A13025.5	–	25.50	1.0039	165.0	286.0	MK 3
A13025.75	–	25.75	1.0138	165.0	286.0	MK 3
A13026.0	–	26.00	1.0236	165.0	286.0	MK 3
A13026.25	–	26.25	1.0335	165.0	286.0	MK 3
A13026.5	–	26.50	1.0433	165.0	286.0	MK 3
A13026.75	–	26.75	1.0531	170.0	291.0	MK 3
A1301.1/16	1.1/16	26.99	1.0625	170.0	291.0	MK 3
A13027.0	–	27.00	1.0630	170.0	291.0	MK 3
A13027.25	–	27.25	1.0728	170.0	291.0	MK 3
A13027.5	–	27.50	1.0827	170.0	291.0	MK 3
A13027.75	–	27.75	1.0925	170.0	291.0	MK 3
A13028.0	–	28.00	1.1024	170.0	291.0	MK 3
A13028.25	–	28.25	1.1122	175.0	296.0	MK 3
A13028.5	–	28.50	1.1220	175.0	296.0	MK 3
A1301.1/8	1.1/8	28.58	1.1250	175.0	296.0	MK 3
A13028.75	–	28.75	1.1319	175.0	296.0	MK 3
A13029.0	–	29.00	1.1417	175.0	296.0	MK 3
A13029.25	–	29.25	1.1516	175.0	296.0	MK 3
A1301.5/32	1.5/32	29.37	1.1563	175.0	296.0	MK 3
A13029.5	–	29.50	1.1614	175.0	296.0	MK 3
A13029.75	–	29.75	1.1713	175.0	296.0	MK 3
A13030.0	–	30.00	1.1811	175.0	296.0	MK 3
A1301.3/16	1.3/16	30.16	1.1875	180.0	301.0	MK 3
A13030.25	–	30.25	1.1909	180.0	301.0	MK 3
A13030.5	–	30.50	1.2008	180.0	301.0	MK 3
A13030.75	–	30.75	1.2106	180.0	301.0	MK 3
A1301.7/32	1.7/32	30.96	1.2188	180.0	301.0	MK 3
A13031.0	–	31.00	1.2205	180.0	301.0	MK 3
A13031.25	–	31.25	1.2303	180.0	301.0	MK 3
A13031.5	–	31.50	1.2402	180.0	301.0	MK 3
A13031.75	–	31.75	1.2500	185.0	306.0	MK 3
A1301.1/4	1.1/4	31.75	1.2500	185.0	306.0	MK 3
A13032.0	–	32.00	1.2598	185.0	334.0	MK 4
A13032.5	–	32.50	1.2795	185.0	334.0	MK 4
A1301.9/32	1.9/32	32.54	1.2813	185.0	334.0	MK 4
A13033.0	–	33.00	1.2992	185.0	334.0	MK 4
A1301.5/16	1.5/16	33.34	1.3125	185.0	334.0	MK 4
A13033.5	–	33.50	1.3189	185.0	334.0	MK 4
A13034.0	–	34.00	1.3386	190.0	339.0	MK 4
A1301.11/32	1.11/32	34.13	1.3438	190.0	339.0	MK 4
A13034.5	–	34.50	1.3583	190.0	339.0	MK 4



Produit	DC	DC	DC	LCF	OAL	CZC MS
	(inch)	(mm)	(inch)	(mm)	(mm)	
A1301.3/8	1.3/8	34.93	1.3750	190.0	339.0	MK 4
A13035.0	–	35.00	1.3780	190.0	339.0	MK 4
A13035.5	–	35.50	1.3976	190.0	339.0	MK 4
A1301.13/32	1.13/32	35.72	1.4063	195.0	344.0	MK 4
A13036.0	–	36.00	1.4173	195.0	344.0	MK 4
A13036.5	–	36.50	1.4370	195.0	344.0	MK 4
A1301.7/16	1.7/16	36.51	1.4375	195.0	344.0	MK 4
A13037.0	–	37.00	1.4567	195.0	344.0	MK 4
A13037.5	–	37.50	1.4764	195.0	344.0	MK 4
A13038.0	–	38.00	1.4961	200.0	349.0	MK 4
A1301.1/2	1.1/2	38.10	1.5000	200.0	349.0	MK 4
A13038.5	–	38.50	1.5157	200.0	349.0	MK 4
A13039.0	–	39.00	1.5354	200.0	349.0	MK 4
A13039.5	–	39.50	1.5551	200.0	349.0	MK 4
A1301.9/16	1.9/16	39.69	1.5625	200.0	349.0	MK 4
A13040.0	–	40.00	1.5748	200.0	349.0	MK 4
A13040.5	–	40.50	1.5945	205.0	354.0	MK 4
A13041.0	–	41.00	1.6142	205.0	354.0	MK 4
A1301.5/8	1.5/8	41.28	1.6250	205.0	354.0	MK 4
A13041.5	–	41.50	1.6339	205.0	354.0	MK 4
A13042.0	–	42.00	1.6535	205.0	354.0	MK 4
A13042.5	–	42.50	1.6732	205.0	354.0	MK 4
A1301.11/16	1.11/16	42.86	1.6875	210.0	359.0	MK 4
A13043.0	–	43.00	1.6929	210.0	359.0	MK 4
A13043.5	–	43.50	1.7126	210.0	359.0	MK 4
A13044.0	–	44.00	1.7323	210.0	359.0	MK 4
A1301.3/4	1.3/4	44.45	1.7500	210.0	359.0	MK 4
A13044.5	–	44.50	1.7520	210.0	359.0	MK 4
A13045.0	–	45.00	1.7717	210.0	359.0	MK 4
A13045.5	–	45.50	1.7913	215.0	364.0	MK 4
A13046.0	–	46.00	1.8110	215.0	364.0	MK 4
A13046.5	–	46.50	1.8307	215.0	364.0	MK 4
A13047.0	–	47.00	1.8504	215.0	364.0	MK 4
A13047.5	–	47.50	1.8701	215.0	364.0	MK 4
A13048.0	–	48.00	1.8898	220.0	369.0	MK 4
A13048.5	–	48.50	1.9094	220.0	369.0	MK 4
A13049.0	–	49.00	1.9291	220.0	369.0	MK 4
A13049.5	–	49.50	1.9488	220.0	369.0	MK 4
A13050.0	–	50.00	1.9685	220.0	369.0	MK 4
A1302	2"	50.80	2.0000	225.0	374.0	MK 4



A530



Foret à queue cône morse en HSS, revêtement TiN

Foret à pointe conventionnelle résistante à 118° qui facilite le réaffûtage. Conception robuste offrant des performances accrues lors d'utilisations sur des machines conventionnelles. Convient pour percer de nombreux matériaux. Le revêtement TiN améliore les performances et prolonge la durée de vie de l'outil.

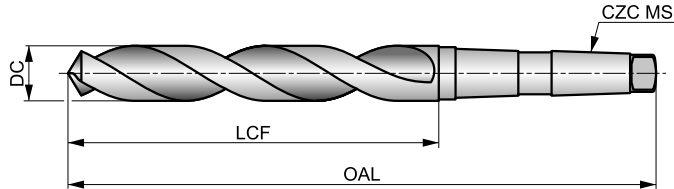

HSS	DIN 345	4xD
118°	TiN	
λ 20-35°	R	DC h8

Adéquation du groupe de matériaux de la pièce, valeurs de départ pour la vitesse de coupe (m/min) et code Alpha d'avance. Les tableaux d'avances par tour se trouvent à partir de la page 175.

P1.1 ■ 40 I	P1.2 ■ 45 I	P1.3 ■ 46 I	P2.1 ■ 34 I	P2.2 ■ 30 F	P2.3 ■ 27 E	P3.1 ■ 29 F	P3.2 ■ 24 F	P3.3 ■ 20 E	P4.1 ■ 18 F	P4.2 ■ 15 E	P4.3 ■ 12 D	M1.1 ■ 33 E	M1.2 ■ 28 E
M2.1 ■ 29 E	M2.2 ■ 24 E	M3.1 ■ 15 G	M3.2 ■ 13 G	M3.3 ■ 12 G	M4.1 ■ 20 C	K1.1 ■ 36 I	K1.2 ■ 27 E	K1.3 ■ 20 E	K2.1 ■ 33 E	K2.2 ■ 27 E	K2.3 ■ 22 E	K3.1 ■ 29 E	K3.2 ■ 22 E
K3.3 ■ 18 E	K4.1 ■ 27 E	K4.2 ■ 21 E	K4.3 ■ 15 E	K4.4 ■ 13 E	K4.5 ■ 11 E	K5.1 ■ 31 E	K5.2 ■ 23 E	K5.3 ■ 18 E	N1.1 ■ 55 I	N1.2 ■ 41 I	N1.3 ■ 28 I	N2.1 ■ 54 G	N2.2 ■ 48 G
N2.3 ■ 35 G	N3.1 ■ 93 G	N3.2 ■ 55 I	N3.3 ■ 28 G	N4.1 ■ 50 J	N4.2 ■ 50 H	N4.3 ■ 35 F	S1.1 ■ 32 F	S1.2 ■ 18 D	S1.3 ■ 13 B	S2.1 ■ 8 E	S2.2 ■ 4 A	S3.1 ■ 6 E	S3.2 ■ 3 A
S4.1 ■ 5 E	S4.2 ■ 2 A												

DC >= 14mm avec pointe amincie.

Produit	DC	DC	LCF	OAL	CZC MS
	(mm)	(inch)			
A5308.5	8.50	0.3346	75.0	156.0	MK 1
A5309.0	9.00	0.3543	81.0	162.0	MK 1
A53010.0	10.00	0.3937	87.0	168.0	MK 1
A53010.2	10.20	0.4016	87.0	168.0	MK 1
A53010.5	10.50	0.4134	87.0	168.0	MK 1
A53011.0	11.00	0.4331	94.0	175.0	MK 1
A53011.5	11.50	0.4528	94.0	175.0	MK 1
A53011.75	11.75	0.4626	94.0	175.0	MK 1
A53012.0	12.00	0.4724	101.0	182.0	MK 1
A53012.5	12.50	0.4921	101.0	182.0	MK 1
A53013.0	13.00	0.5118	101.0	182.0	MK 1
A53013.5	13.50	0.5315	108.0	189.0	MK 1
A53014.0	14.00	0.5512	108.0	189.0	MK 1
A53014.5	14.50	0.5709	114.0	212.0	MK 2
A53015.0	15.00	0.5906	114.0	212.0	MK 2
A53015.25	15.25	0.6004	120.0	218.0	MK 2
A53015.5	15.50	0.6102	120.0	218.0	MK 2
A53016.0	16.00	0.6299	120.0	218.0	MK 2
A53016.5	16.50	0.6496	125.0	223.0	MK 2
A53017.0	17.00	0.6693	125.0	223.0	MK 2
A53017.5	17.50	0.6890	130.0	228.0	MK 2
A53018.0	18.00	0.7087	130.0	228.0	MK 2
A53018.5	18.50	0.7283	135.0	233.0	MK 2
A53019.0	19.00	0.7480	135.0	233.0	MK 2
A53019.5	19.50	0.7677	140.0	238.0	MK 2
A53020.0	20.00	0.7874	140.0	238.0	MK 2

Produit	DC	DC	LCF	OAL	CZC MS
	(mm)	(inch)			
A53020.5	20.50	0.8071	145.0	243.0	MK 2
A53021.0	21.00	0.8268	145.0	243.0	MK 2
A53021.5	21.50	0.8465	150.0	248.0	MK 2
A53022.0	22.00	0.8661	150.0	248.0	MK 2
A53022.5	22.50	0.8858	155.0	253.0	MK 2
A53023.0	23.00	0.9055	155.0	253.0	MK 2
A53023.5	23.50	0.9252	155.0	276.0	MK 3
A53024.0	24.00	0.9449	160.0	281.0	MK 3
A53024.5	24.50	0.9646	160.0	281.0	MK 3
A53025.0	25.00	0.9843	160.0	281.0	MK 3
A53025.5	25.50	1.0039	165.0	286.0	MK 3
A53026.0	26.00	1.0236	165.0	286.0	MK 3
A53026.5	26.50	1.0433	165.0	286.0	MK 3
A53027.0	27.00	1.0630	170.0	291.0	MK 3
A53027.5	27.50	1.0827	170.0	291.0	MK 3
A53028.0	28.00	1.1024	170.0	291.0	MK 3
A53028.5	28.50	1.1220	175.0	296.0	MK 3
A53029.0	29.00	1.1417	175.0	296.0	MK 3
A53029.5	29.50	1.1614	175.0	296.0	MK 3
A53030.0	30.00	1.1811	175.0	296.0	MK 3
A53031.0	31.00	1.2205	180.0	301.0	MK 3
A53032.0	32.00	1.2598	185.0	334.0	MK 4
A53033.0	33.00	1.2992	185.0	334.0	MK 4
A53035.0	35.00	1.3780	190.0	339.0	MK 4
A53040.0	40.00	1.5748	200.0	349.0	MK 4



A730



Foret à queue cône morse en HSS-E (8% cobalt), finition avec traitement bronze

Foret recommandé pour les matériaux et les applications difficiles. La pointe à 118° est résistante et facile à réaffûter. Convient pour le perçage de nombreux matériaux. La finition avec traitement bronze est une fine couche d'oxyde et c'est une indication pour le cobalt.

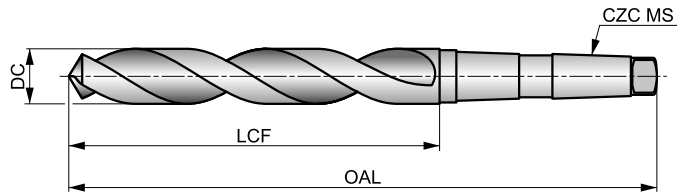

HSS-E	DIN 345	4xD
118°	Bronze	
λ 20-35°	R	DC h8

Adéquation du groupe de matériaux de la pièce, valeurs de départ pour la vitesse de coupe (m/min) et code Alpha d'avance. Les tableaux d'avances par tour se trouvent à partir de la page 175.

P1.1 ■ 36 H	P1.2 ■ 40 H	P1.3 ■ 41 H	P2.1 ■ 31 H	P2.2 ■ 27 G	P2.3 ■ 24 E	P3.1 ■ 25 F	P3.2 ■ 20 F	P3.3 ■ 17 E	P4.1 ■ 15 F	P4.2 ■ 13 E	P4.3 ■ 10 D	M1.1 ■ 33 E	M1.2 ■ 28 E
M2.1 ■ 29 E	M2.2 ■ 24 E	M3.1 ■ 13 G	M3.2 ■ 11 G	M3.3 ■ 10 G	M4.1 ■ 17 C	K1.1 ■ 35 J	K1.2 ■ 26 G	K1.3 ■ 19 G	K2.1 ■ 27 E	K2.2 ■ 22 E	K2.3 ■ 18 E	K3.1 ■ 24 E	K3.2 ■ 18 E
K3.3 ■ 15 E	K4.1 ■ 22 E	K4.2 ■ 17 E	K4.3 ■ 12 E	K4.4 ■ 11 E	K4.5 ■ 9 E	K5.1 ■ 25 E	K5.2 ■ 19 E	K5.3 ■ 15 E	N1.1 ■ 33 J	N1.2 ■ 25 J	N1.3 ■ 17 I	N2.1 ■ 46 H	N2.2 ■ 42 H
N2.3 ■ 30 H	N3.1 ■ 68 H	N3.2 ■ 40 J	N3.3 ■ 20 L	N4.1 ■ 35 K	N4.2 ■ 28 J	N4.3 ■ 20 H	S1.1 ■ 28 G	S1.2 ■ 20 D	S1.3 ■ 11 C	S2.1 ■ 9 E	S2.2 ■ 8 B	S3.1 ■ 7 E	S3.2 ■ 6 B
S4.1 ■ 5 E	S4.2 ■ 5 B												

DC >= 14mm avec pointe amincie.

Produit	DC	DC	LCF	OAL	CZC MS	Produit	DC	DC	LCF	OAL	CZC MS
	(mm)	(inch)					(mm)	(mm)			
A73010.0	10.00	0.3937	87.0	168.0	MK 1	A73016.25	16.25	0.6398	120.0	218.0	MK 2
A73010.2	10.20	0.4016	87.0	168.0	MK 1	A73016.5	16.50	0.6496	125.0	223.0	MK 2
A73010.5	10.50	0.4134	87.0	168.0	MK 1	A73017.0	17.00	0.6693	125.0	223.0	MK 2
A73010.8	10.80	0.4252	94.0	175.0	MK 1	A73017.25	17.25	0.6791	130.0	228.0	MK 2
A73011.0	11.00	0.4331	94.0	175.0	MK 1	A73017.5	17.50	0.6890	130.0	228.0	MK 2
A73011.5	11.50	0.4528	94.0	175.0	MK 1	A73017.75	17.75	0.6988	130.0	228.0	MK 2
A73011.8	11.80	0.4646	94.0	175.0	MK 1	A73018.0	18.00	0.7087	130.0	228.0	MK 2
A73012.0	12.00	0.4724	101.0	182.0	MK 1	A73018.25	18.25	0.7185	135.0	233.0	MK 2
A73012.2	12.20	0.4803	101.0	182.0	MK 1	A73018.5	18.50	0.7283	135.0	233.0	MK 2
A73012.5	12.50	0.4921	101.0	182.0	MK 1	A73018.75	18.75	0.7382	135.0	233.0	MK 2
A73012.8	12.80	0.5039	101.0	182.0	MK 1	A73019.0	19.00	0.7480	135.0	233.0	MK 2
A73013.0	13.00	0.5118	101.0	182.0	MK 1	A73019.25	19.25	0.7579	140.0	238.0	MK 2
A73013.5	13.50	0.5315	108.0	189.0	MK 1	A73019.5	19.50	0.7677	140.0	238.0	MK 2
A73013.8	13.80	0.5433	108.0	189.0	MK 1	A73019.75	19.75	0.7776	140.0	238.0	MK 2
A73014.0	14.00	0.5512	108.0	189.0	MK 1	A73020.0	20.00	0.7874	140.0	238.0	MK 2
A73014.25	14.25	0.5610	114.0	212.0	MK 2	A73020.25	20.25	0.7972	145.0	243.0	MK 2
A73014.5	14.50	0.5709	114.0	212.0	MK 2	A73020.5	20.50	0.8071	145.0	243.0	MK 2
A73014.75	14.75	0.5807	114.0	212.0	MK 2	A73020.75	20.75	0.8169	145.0	243.0	MK 2
A73015.0	15.00	0.5906	114.0	212.0	MK 2	A73021.0	21.00	0.8268	145.0	243.0	MK 2
A73015.25	15.25	0.6004	120.0	218.0	MK 2	A73021.5	21.50	0.8465	150.0	248.0	MK 2
A73015.5	15.50	0.6102	120.0	218.0	MK 2	A73022.0	22.00	0.8661	150.0	248.0	MK 2
A73015.75	15.75	0.6201	120.0	218.0	MK 2	A73022.5	22.50	0.8858	155.0	253.0	MK 2
A73016.0	16.00	0.6299	120.0	218.0	MK 2	A73023.0	23.00	0.9055	155.0	253.0	MK 2



Produit	DC	DC	LCF	OAL	CZC MS
	(mm)	(inch)	(mm)	(mm)	
A73023.5	23.50	0.9252	155.0	276.0	MK 3
A73024.0	24.00	0.9449	160.0	281.0	MK 3
A73024.5	24.50	0.9646	160.0	281.0	MK 3
A73025.0	25.00	0.9843	160.0	281.0	MK 3
A73025.5	25.50	1.0039	165.0	286.0	MK 3
A73026.0	26.00	1.0236	165.0	286.0	MK 3
A73026.5	26.50	1.0433	165.0	286.0	MK 3
A73027.0	27.00	1.0630	170.0	291.0	MK 3

Produit	DC	DC	LCF	OAL	CZC MS
	(mm)	(inch)	(mm)	(mm)	
A73027.5	27.50	1.0827	170.0	291.0	MK 3
A73028.0	28.00	1.1024	170.0	291.0	MK 3
A73028.5	28.50	1.1220	175.0	296.0	MK 3
A73029.0	29.00	1.1417	175.0	296.0	MK 3
A73030.0	30.00	1.1811	175.0	296.0	MK 3
A73031.0	31.00	1.2205	180.0	301.0	MK 3
A73032.0	32.00	1.2598	185.0	334.0	MK 4



A166



Foret à queue cône morse en HSS, finition avec traitement vapeur, avec pointe en carbure brasée

Foret à pointe en carbure brasée offrant les performances élevées d'un foret en carbure monobloc grâce à son corps en HSS moins cassant. Sa pointe à 118° à quatre facettes facilite l'auto-centrage et est facile à réaffûter, ce qui en fait un choix économique pour le perçage de matériaux en fonte.

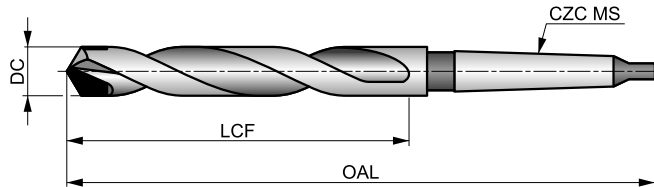

HSS HM	DIN 345	4xD
118°	Bright ST	
20-35°	R	DC h8

Adéquation du groupe de matériaux de la pièce, valeurs de départ pour la vitesse de coupe (m/min) et code Alpha d'avance. Les tableaux d'avances par tour se trouvent à partir de la page 175.

P1.1 73 E	P1.2 82 E	P1.3 85 E	P2.1 63 E	P2.2 55 D	P2.3 49 C	P3.1 59 D	P3.2 47 D	P3.3 40 C	P4.1 35 D	P4.2 30 C	P4.3 24 A	M1.1 55 B	M1.2 46 B
M2.1 49 B	M2.2 40 B	M3.1 41 C	M3.2 35 C	M3.3 32 C	M4.1 35 A	K1.1 50 C	K1.2 37 C	K1.3 28 C	K2.1 43 C	K2.2 35 C	K2.3 28 A	K3.1 38 C	K3.2 29 C
K3.3 24 A	K4.1 35 C	K4.2 27 C	K4.3 20 A	K4.4 17 A	K4.5 14 A	K5.1 40 C	K5.2 30 C	K5.3 23 A	N1.1 50 I	N1.2 38 I	N1.3 25 H	N2.1 62 G	N2.2 55 G
N2.3 40 G	N3.1 127 C	N3.2 75 G	N3.3 38 D	N4.2 60 E	S1.1 35 A	S1.2 35 A	S1.3 25 A	S2.1 33 A	S2.2 28 A	S3.1 25 A	S3.2 20 A	S4.1 20 A	S4.2 16 A

Produit	DC	DC	LCF	OAL	CZC MS	Produit	DC	DC	LCF	OAL	CZC MS
	(mm)	(inch)					(mm)	(mm)			
A16610.0	10.00	0.3937	87.0	168.0	MK 1	A16620.0	20.00	0.7874	140.0	238.0	MK 2
A16610.5	10.50	0.4134	87.0	168.0	MK 1	A16621.0	21.00	0.8268	145.0	243.0	MK 2
A16611.0	11.00	0.4331	94.0	175.0	MK 1	A16622.0	22.00	0.8661	150.0	248.0	MK 2
A16611.5	11.50	0.4528	94.0	175.0	MK 1	A16622.5	22.50	0.8858	155.0	253.0	MK 2
A16612.0	12.00	0.4724	101.0	182.0	MK 1	A16623.0	23.00	0.9055	155.0	253.0	MK 2
A16613.0	13.00	0.5118	101.0	182.0	MK 1	A16624.0	24.00	0.9449	160.0	281.0	MK 3
A16613.5	13.50	0.5315	108.0	189.0	MK 1	A16625.0	25.00	0.9843	160.0	281.0	MK 3
A16614.0	14.00	0.5512	108.0	189.0	MK 1	A16626.0	26.00	1.0236	165.0	286.0	MK 3
A16615.0	15.00	0.5906	114.0	212.0	MK 2	A16627.0	27.00	1.0630	170.0	291.0	MK 3
A16616.0	16.00	0.6299	120.0	218.0	MK 2	A16628.0	28.00	1.1024	170.0	291.0	MK 3
A16617.0	17.00	0.6693	125.0	223.0	MK 2	A16629.0	29.00	1.1417	175.0	296.0	MK 3
A16617.5	17.50	0.6890	130.0	228.0	MK 2	A16630.0	30.00	1.1811	175.0	296.0	MK 3
A16618.0	18.00	0.7087	130.0	228.0	MK 2	A16632.0	32.00	1.2598	185.0	334.0	MK 4
A16619.0	19.00	0.7480	135.0	233.0	MK 2	A16633.0	33.00	1.2992	185.0	334.0	MK 4



A350



Foret à queue cône morse série longue en HSS, finition avec traitement vapeur

Foret recommandé pour le perçage de trous profonds ou pour les applications nécessitant une portée accrue. La finition avec traitement vapeur retient le liquide de coupe et empêche le collage des copeaux sur l'outil. L'angle de pointe à 118° est facile à réaffûter et procure de la résistance. Convient pour le perçage de nombreux matériaux.

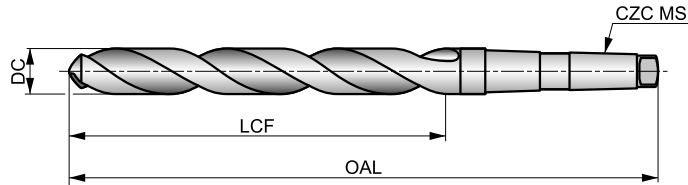

HSS	DIN 341	6xD
118°	ST	
λ 20-35°	R	DC h8

Adéquation du groupe de matériaux de la pièce, valeurs de départ pour la vitesse de coupe (m/min) et code Alpha d'avance. Les tableaux d'avances par tour se trouvent à partir de la page 175.

P1.1 ■ 27 I	P1.2 ■ 30 I	P1.3 ■ 31 I	P2.1 ■ 23 I	P2.2 ■ 20 G	P2.3 ■ 18 E	P3.1 ■ 15 F	P3.2 ■ 12 F	P3.3 ■ 10 E	P4.1 ■ 9 F	P4.2 ■ 7 E	P4.3 ■ 6 D	M1.1 ■ 18 E	M1.2 ■ 15 E
M2.1 ■ 16 E	M2.2 ■ 13 E	M3.1 ■ 5 G	M3.2 ■ 4 G	M3.3 ■ 4 G	M4.1 ■ 8 C	K1.1 ■ 26 I	K1.2 ■ 19 F	K1.3 ■ 14 F	K2.1 ■ 22 E	K2.2 ■ 18 E	K2.3 ■ 14 E	K3.1 ■ 20 E	K3.2 ■ 15 E
K3.3 ■ 12 E	K4.1 ■ 18 E	K4.2 ■ 14 E	K4.3 ■ 10 E	K4.4 ■ 9 E	K4.5 ■ 7 E	K5.1 ■ 21 E	K5.2 ■ 15 E	K5.3 ■ 12 E	N1.1 ■ 33 J	N1.2 ■ 25 J	N1.3 ■ 17 I	N2.1 ■ 42 H	N2.2 ■ 37 H
N2.3 ■ 27 H	N3.1 ■ 59 H	N3.2 ■ 35 I	N3.3 ■ 18 F	N4.1 ■ 35 L	N4.2 ■ 26 J	N4.3 ■ 12 H	S1.1 ■ 16 F	S1.2 ■ 9 D	S1.3 ■ 5 B	S2.1 ■ 5 E	S2.2 ■ 4 A	S3.1 ■ 4 E	S3.2 ■ 3 A
S4.1 ■ 3 E	S4.2 ■ 2 A												

Produit	DC	DC	LCF	OAL	CZC MS
	(mm)	(inch)			
A3505.0	5.00	0.1969	74.0	155.0	MK 1
A3505.5	5.50	0.2165	80.0	161.0	MK 1
A3506.0	6.00	0.2362	80.0	161.0	MK 1
A3506.7	6.70	0.2638	86.0	167.0	MK 1
A3506.8	6.80	0.2677	93.0	174.0	MK 1
A3507.0	7.00	0.2756	93.0	174.0	MK 1
A3507.5	7.50	0.2953	93.0	174.0	MK 1
A3508.0	8.00	0.3150	100.0	181.0	MK 1
A3508.4	8.40	0.3307	100.0	181.0	MK 1
A3508.5	8.50	0.3346	100.0	181.0	MK 1
A3508.75	8.75	0.3445	107.0	188.0	MK 1
A3509.0	9.00	0.3543	107.0	188.0	MK 1
A3509.5	9.50	0.3740	107.0	188.0	MK 1
A3509.8	9.80	0.3858	116.0	197.0	MK 1
A35010.0	10.00	0.3937	116.0	197.0	MK 1
A35010.2	10.20	0.4016	116.0	197.0	MK 1
A35010.5	10.50	0.4134	116.0	197.0	MK 1
A35010.7	10.70	0.4213	125.0	206.0	MK 1
A35011.0	11.00	0.4331	125.0	206.0	MK 1
A35011.5	11.50	0.4528	125.0	206.0	MK 1
A35011.75	11.75	0.4626	125.0	206.0	MK 1
A35011.8	11.80	0.4646	125.0	206.0	MK 1
A35012.0	12.00	0.4724	134.0	215.0	MK 1
A35012.5	12.50	0.4921	134.0	215.0	MK 1

Produit	DC	DC	LCF	OAL	CZC MS
	(mm)	(inch)			
A35013.0	13.00	0.5118	134.0	215.0	MK 1
A35013.5	13.50	0.5315	142.0	223.0	MK 1
A35014.0	14.00	0.5512	142.0	223.0	MK 1
A35014.25	14.25	0.5610	147.0	245.0	MK 2
A35014.5	14.50	0.5709	147.0	245.0	MK 2
A35014.75	14.75	0.5807	147.0	245.0	MK 2
A35015.0	15.00	0.5906	147.0	245.0	MK 2
A35015.25	15.25	0.6004	153.0	251.0	MK 2
A35015.5	15.50	0.6102	153.0	251.0	MK 2
A35015.75	15.75	0.6201	153.0	251.0	MK 2
A35016.0	16.00	0.6299	153.0	251.0	MK 2
A35016.25	16.25	0.6398	159.0	257.0	MK 2
A35016.5	16.50	0.6496	159.0	257.0	MK 2
A35016.75	16.75	0.6594	159.0	257.0	MK 2
A35017.0	17.00	0.6693	159.0	257.0	MK 2
A35017.25	17.25	0.6791	165.0	263.0	MK 2
A35017.5	17.50	0.6890	165.0	263.0	MK 2
A35018.0	18.00	0.7087	165.0	263.0	MK 2
A35018.5	18.50	0.7283	171.0	269.0	MK 2
A35019.0	19.00	0.7480	171.0	269.0	MK 2
A35019.5	19.50	0.7677	177.0	275.0	MK 2
A35019.75	19.75	0.7776	177.0	275.0	MK 2
A35020.0	20.00	0.7874	177.0	275.0	MK 2
A35020.25	20.25	0.7972	184.0	282.0	MK 2



Produit	DC	DC	LCF	OAL	CZC MS
	(mm)	(inch)	(mm)	(mm)	
A35020.5	20.50	0.8071	184.0	282.0	MK 2
A35021.0	21.00	0.8268	184.0	282.0	MK 2
A35021.5	21.50	0.8465	191.0	289.0	MK 2
A35022.0	22.00	0.8661	191.0	289.0	MK 2
A35022.5	22.50	0.8858	198.0	296.0	MK 2
A35023.0	23.00	0.9055	198.0	296.0	MK 2
A35023.5	23.50	0.9252	198.0	319.0	MK 3
A35024.0	24.00	0.9449	206.0	327.0	MK 3
A35024.5	24.50	0.9646	206.0	327.0	MK 3
A35025.0	25.00	0.9843	206.0	327.0	MK 3
A35025.5	25.50	1.0039	214.0	335.0	MK 3
A35026.0	26.00	1.0236	214.0	335.0	MK 3
A35026.5	26.50	1.0433	214.0	335.0	MK 3
A35027.0	27.00	1.0630	222.0	343.0	MK 3
A35027.5	27.50	1.0827	222.0	343.0	MK 3
A35028.0	28.00	1.1024	222.0	343.0	MK 3
A35029.0	29.00	1.1417	230.0	351.0	MK 3
A35030.0	30.00	1.1811	230.0	351.0	MK 3
A35030.5	30.50	1.2008	239.0	360.0	MK 3
A35031.0	31.00	1.2205	239.0	360.0	MK 3

Produit	DC	DC	LCF	OAL	CZC MS
	(mm)	(inch)	(mm)	(mm)	
A35031.5	31.50	1.2402	239.0	360.0	MK 3
A35032.0	32.00	1.2598	248.0	397.0	MK 4
A35033.0	33.00	1.2992	248.0	397.0	MK 4
A35034.0	34.00	1.3386	257.0	406.0	MK 4
A35035.0	35.00	1.3780	257.0	406.0	MK 4
A35036.0	36.00	1.4173	267.0	416.0	MK 4
A35037.0	37.00	1.4567	267.0	416.0	MK 4
A35038.0	38.00	1.4961	277.0	426.0	MK 4
A35039.0	39.00	1.5354	277.0	426.0	MK 4
A35040.0	40.00	1.5748	277.0	426.0	MK 4
A35041.0	41.00	1.6142	287.0	436.0	MK 4
A35042.0	42.00	1.6535	287.0	436.0	MK 4
A35043.0	43.00	1.6929	298.0	447.0	MK 4
A35044.0	44.00	1.7323	298.0	447.0	MK 4
A35045.0	45.00	1.7717	298.0	447.0	MK 4
A35046.0	46.00	1.8110	310.0	459.0	MK 4
A35047.0	47.00	1.8504	310.0	459.0	MK 4
A35048.0	48.00	1.8898	321.0	470.0	MK 4
A35050.0	50.00	1.9685	321.0	470.0	MK 4



A345



Foret série longue à queue cône morse (DIN 1870 série 1) en HSS, finition avec traitement vapeur

Foret recommandé pour le perçage de trous très profonds ou pour les applications nécessitant une portée accrue. La pointe à 118° est facile à réaffûter et procure de la résistance. La finition avec traitement vapeur retient le liquide de coupe et empêche le collage des copeaux sur l'outil. Convient pour le perçage de nombreux matériaux.

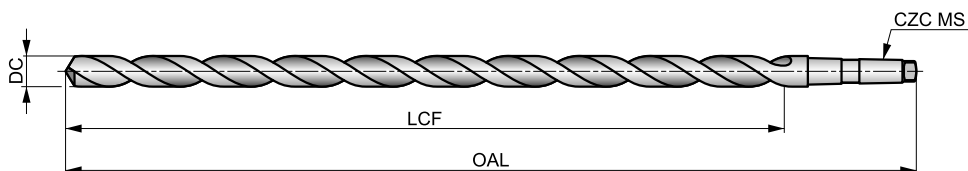

HSS	DIN 1870(1)	10xD
118°	ST	
λ 20-35°	R	DC h8

Adéquation du groupe de matériaux de la pièce, valeurs de départ pour la vitesse de coupe (m/min) et code Alpha d'avance. Les tableaux d'avances par tour se trouvent à partir de la page 175.

P1.1 ■ 23 G	P1.2 ■ 25 G	P1.3 ■ 26 G	P2.1 ■ 19 G	P2.2 ■ 17 E	P2.3 ■ 15 C	P3.1 ■ 9 D	P3.2 ■ 7 D	P3.3 ■ 6 C	P4.1 ■ 5 D	P4.2 ■ 4 C	P4.3 ■ 4 B	M1.1 ■ 16 C	M1.2 ■ 14 C
M2.1 ■ 15 C	M2.2 ■ 12 C	M3.1 ■ 5 E	M3.2 ■ 4 E	M3.3 ■ 4 E	M4.1 ■ 8 A	K1.1 ■ 22 G	K1.2 ■ 16 D	K1.3 ■ 12 D	K2.1 ■ 16 C	K2.2 ■ 13 C	K2.3 ■ 10 C	K3.1 ■ 14 C	K3.2 ■ 11 C
K3.3 ■ 9 C	K4.1 ■ 13 C	K4.2 ■ 10 C	K4.3 ■ 7 C	K4.4 ■ 6 C	K4.5 ■ 5 C	K5.1 ■ 15 C	K5.2 ■ 11 C	K5.3 ■ 9 C	N1.1 ■ 33 H	N1.2 ■ 25 H	N1.3 ■ 17 G	N2.1 ■ 42 F	N2.2 ■ 37 F
N2.3 ■ 27 F	N3.1 ■ 56 F	N3.2 ■ 33 G	N3.3 ■ 17 D	N4.1 ■ 30 J	N4.2 ■ 30 H	N4.3 ■ 10 F	S1.1 ■ 15 D	S1.2 ■ 9 B	S1.3 ■ 5 A	S2.1 ■ 5 C	S2.2 ■ 4 A	S3.1 ■ 4 C	S3.2 ■ 3 A
S4.1 ■ 3 C	S4.2 ■ 2 A												

DC > 25.4mm moins de 10xD.

Produit	DC	DC	DC	LCF	OAL	CZC MS
	(inch)	(mm)	(inch)			
A3458.0	–	8.00	0.3150	165.0	265.0	MK 1
A3458.5	–	8.50	0.3346	165.0	265.0	MK 1
A3459.0	–	9.00	0.3543	175.0	275.0	MK 1
A3459.5	–	9.50	0.3740	175.0	275.0	MK 1
A3453/8	3/8	9.52	0.3750	185.0	285.0	MK 1
A34510.0	–	10.00	0.3937	185.0	285.0	MK 1
A34513/32	13/32	10.32	0.4063	185.0	285.0	MK 1
A34510.5	–	10.50	0.4134	185.0	285.0	MK 1
A34511.0	–	11.00	0.4331	195.0	300.0	MK 1
A3457/16	7/16	11.11	0.4375	195.0	300.0	MK 1
A34511.5	–	11.50	0.4528	195.0	300.0	MK 1
A34529/64	29/64	11.51	0.4531	205.0	310.0	MK 1
A34512.0	–	12.00	0.4724	205.0	310.0	MK 1
A34512.5	–	12.50	0.4921	205.0	310.0	MK 1
A3451/2	1/2	12.70	0.5000	205.0	310.0	MK 1
A34513.0	–	13.00	0.5118	205.0	310.0	MK 1
A34517/32	17/32	13.49	0.5313	220.0	325.0	MK 1
A34513.5	–	13.50	0.5315	220.0	325.0	MK 1
A34514.0	–	14.00	0.5512	220.0	325.0	MK 1
A3459/16	9/16	14.29	0.5625	220.0	340.0	MK 2
A34537/64	37/64	14.68	0.5781	220.0	340.0	MK 2
A34515.0	–	15.00	0.5906	220.0	340.0	MK 2
A34539/64	39/64	15.48	0.6094	230.0	355.0	MK 2

Produit	DC	DC	DC	LCF	OAL	CZC MS
	(inch)	(mm)	(inch)			
A34515.5	–	15.50	0.6102	230.0	355.0	MK 2
A3455/8	5/8	15.88	0.6250	230.0	355.0	MK 2
A34516.0	–	16.00	0.6299	230.0	355.0	MK 2
A34541/64	41/64	16.27	0.6406	230.0	355.0	MK 2
A34516.5	–	16.50	0.6496	230.0	355.0	MK 2
A34521/32	21/32	16.67	0.6563	230.0	355.0	MK 2
A34517.0	–	17.00	0.6693	230.0	355.0	MK 2
A34511/16	11/16	17.46	0.6875	245.0	370.0	MK 2
A34517.5	–	17.50	0.6890	245.0	370.0	MK 2
A34518.0	–	18.00	0.7087	245.0	370.0	MK 2
A34518.5	–	18.50	0.7283	245.0	370.0	MK 2
A34519.0	–	19.00	0.7480	245.0	370.0	MK 2
A3453/4	3/4	19.05	0.7500	260.0	385.0	MK 2
A34519.5	–	19.50	0.7677	260.0	385.0	MK 2
A34520.0	–	20.00	0.7874	260.0	385.0	MK 2
A34520.5	–	20.50	0.8071	260.0	385.0	MK 2
A34521.0	–	21.00	0.8268	260.0	385.0	MK 2
A34521.5	–	21.50	0.8465	270.0	405.0	MK 2
A34522.0	–	22.00	0.8661	270.0	405.0	MK 2
A3457/8	7/8	22.22	0.8750	270.0	405.0	MK 2
A34522.5	–	22.50	0.8858	270.0	405.0	MK 3
A34523.0	–	23.00	0.9055	270.0	405.0	MK 3
A34523.5	–	23.50	0.9252	270.0	425.0	MK 3



Produit	DC	DC	DC	LCF	OAL	CZC MS
	(inch)	(mm)	(inch)	(mm)	(mm)	
A34524.0	–	24.00	0.9449	290.0	440.0	MK 3
A34524.5	–	24.50	0.9646	290.0	440.0	MK 3
A34525.0	–	25.00	0.9843	290.0	440.0	MK 3
A3451	1"	25.40	1.0000	290.0	440.0	MK 3
A34525.5	–	25.50	1.0039	290.0	440.0	MK 3
A34526.0	–	26.00	1.0236	290.0	440.0	MK 3
A34526.5	–	26.50	1.0433	290.0	440.0	MK 3
A34527.0	–	27.00	1.0630	305.0	460.0	MK 3
A34528.0	–	28.00	1.1024	305.0	460.0	MK 3
A34529.0	–	29.00	1.1417	305.0	460.0	MK 3
A34530.0	–	30.00	1.1811	305.0	460.0	MK 3
A3451.1/4	1.1/4	31.75	1.2500	320.0	480.0	MK 3

Produit	DC	DC	DC	LCF	OAL	CZC MS
	(inch)	(mm)	(inch)	(mm)	(mm)	
A34531.0	–	31.00	1.2205	320.0	480.0	MK 3
A34532.0	–	32.00	1.2598	320.0	505.0	MK 4
A34533.0	–	33.00	1.2992	320.0	505.0	MK 4
A34534.0	–	34.00	1.3386	340.0	530.0	MK 4
A34535.0	–	35.00	1.3780	340.0	530.0	MK 4
A34536.0	–	36.00	1.4173	340.0	530.0	MK 4
A34537.0	–	37.00	1.4567	340.0	530.0	MK 4
A34538.0	–	38.00	1.4961	360.0	555.0	MK 4
A3451.1/2	1.1/2	38.10	1.5000	360.0	555.0	MK 4
A34539.0	–	39.00	1.5354	360.0	555.0	MK 4
A34540.0	–	40.00	1.5748	360.0	555.0	MK 4



A951



Foret à queue cône morse (DIN 1870 série 1) série extra longue PFX en HSS, finition brillante

Foret polyvalent avec une conception spéciale de goujure parabolique pour percer des trous profonds en un seul passage. Le foret a une pointe auto-centrante à 130° (le centrage avec un foret PFX court est recommandé) de sorte que la force nécessaire pour percer le trou est réduite. Convient pour percer de nombreux matériaux.

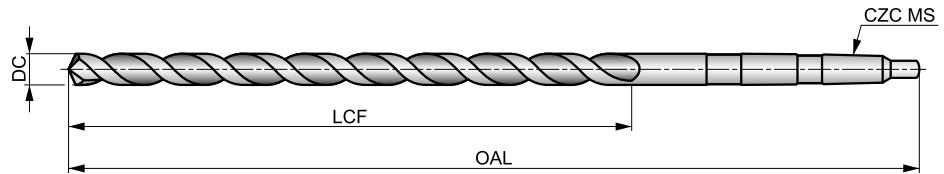

HSS	DIN 1870(1)	15×D
130°	Bright ST	
$\lambda > 35^\circ$	R	DC h8

Adéquation du groupe de matériaux de la pièce, valeurs de départ pour la vitesse de coupe (m/min) et code Alpha d'avance. Les tableaux d'avances par tour se trouvent à partir de la page 175.

P1.1 ■ 25 G	P1.2 ■ 28 G	P1.3 ■ 29 G	P2.1 ■ 22 G	P2.2 ■ 19 E	P2.3 ■ 17 C	P3.1 ■ 12 D	P3.2 ■ 9 D	P3.3 ■ 8 C	P4.1 ■ 7 D	P4.2 ■ 6 C	P4.3 ■ 5 B	M1.1 ■ 16 C	M1.2 ■ 14 C
M2.1 ■ 15 C	M2.2 ■ 12 C	M3.1 ■ 7 E	M3.2 ■ 6 E	M3.3 ■ 5 E	M4.1 ■ 12 A	K1.1 ■ 22 G	K1.2 ■ 16 D	K1.3 ■ 12 D	K2.1 ■ 16 C	K2.2 ■ 13 C	K2.3 ■ 10 C	K3.1 ■ 14 C	K3.2 ■ 11 C
K3.3 ■ 9 C	K4.1 ■ 13 C	K4.2 ■ 10 C	K4.3 ■ 7 C	K4.4 ■ 6 C	K4.5 ■ 5 C	K5.1 ■ 15 C	K5.2 ■ 11 C	K5.3 ■ 9 C	N1.1 ■ 30 H	N1.2 ■ 23 H	N1.3 ■ 15 G	N2.1 ■ 37 F	N2.2 ■ 33 F
N2.3 ■ 24 F	N3.1 ■ 56 F	N3.2 ■ 33 G	N3.3 ■ 17 D	N4.1 ■ 30 J	N4.2 ■ 30 H	N4.3 ■ 10 F	S1.1 ■ 18 D	S1.2 ■ 10 B	S1.3 ■ 6 A	S2.1 ■ 7 C	S2.2 ■ 4 A	S3.1 ■ 5 C	S3.2 ■ 3 A
S4.1 ■ 4 C	S4.2 ■ 2 A												

DC >= 14.5mm moins de 15xD; DC > 23mm Brillant.

Produit	DC	DC	LCF	OAL	CZC MS
	(mm)	(inch)			
A95110.0	10.00	0.3937	185.0	285.0	MK 1
A95111.0	11.00	0.4331	195.0	300.0	MK 1
A95112.0	12.00	0.4724	205.0	310.0	MK 1
A95112.5	12.50	0.4921	205.0	310.0	MK 1
A95113.0	13.00	0.5118	205.0	310.0	MK 1
A95113.5	13.50	0.5315	220.0	325.0	MK 1
A95114.0	14.00	0.5512	220.0	325.0	MK 1
A95114.5	14.50	0.5709	220.0	340.0	MK 2
A95115.0	15.00	0.5906	220.0	340.0	MK 2
A95115.5	15.50	0.6102	230.0	355.0	MK 2
A95116.0	16.00	0.6299	230.0	355.0	MK 2
A95116.5	16.50	0.6496	230.0	355.0	MK 2
A95117.0	17.00	0.6693	230.0	355.0	MK 2
A95117.5	17.50	0.6890	245.0	370.0	MK 2
A95118.0	18.00	0.7087	245.0	370.0	MK 2

Produit	DC	DC	LCF	OAL	CZC MS
	(mm)	(inch)			
A95118.5	18.50	0.7283	245.0	370.0	MK 2
A95119.0	19.00	0.7480	245.0	370.0	MK 2
A95119.5	19.50	0.7677	260.0	385.0	MK 2
A95120.0	20.00	0.7874	260.0	385.0	MK 2
A95121.0	21.00	0.8268	260.0	385.0	MK 2
A95122.0	22.00	0.8661	270.0	405.0	MK 2
A95123.0	23.00	0.9055	270.0	405.0	MK 2
A95124.0	24.00	0.9449	290.0	440.0	MK 3
A95125.0	25.00	0.9843	290.0	440.0	MK 3
A95126.0	26.00	1.0236	290.0	440.0	MK 3
A95127.0	27.00	1.0630	305.0	460.0	MK 3
A95128.0	28.00	1.1024	305.0	460.0	MK 3
A95129.0	29.00	1.1417	305.0	460.0	MK 3
A95130.0	30.00	1.1811	305.0	460.0	MK 3



A952



Foret à queue cône morse (DIN 1870 série 2) série extra longue PFX en HSS, finition brillante

Foret polyvalent avec une conception spéciale de goujure parabolique pour percer des trous profonds en un seul passage. Le foret a une pointe auto-centrante à 130° (le centrage avec un foret PFX court est recommandé) de sorte que la force nécessaire pour percer le trou est réduite. Convient pour percer de nombreux matériaux.

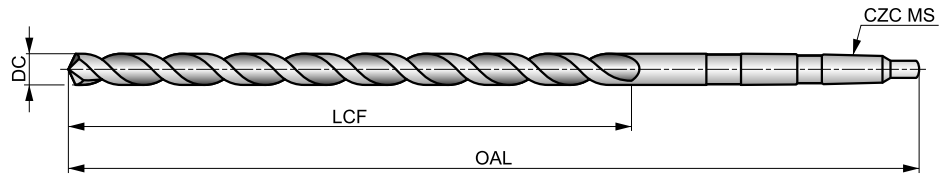

HSS	DIN 1870(2)	20xD
130°	Bright ST	
$\lambda > 35^\circ$	R	DC h8

Adéquation du groupe de matériaux de la pièce, valeurs de départ pour la vitesse de coupe (m/min) et code Alpha d'avance. Les tableaux d'avances par tour se trouvent à partir de la page 175.

P1.1 ■ 25 G	P1.2 ■ 28 G	P1.3 ■ 29 G	P2.1 ■ 22 G	P2.2 ■ 19 E	P2.3 ■ 17 C	P3.1 ■ 12 D	P3.2 ■ 9 D	P3.3 ■ 8 C	P4.1 ■ 7 D	P4.2 ■ 6 C	P4.3 ■ 5 B	M1.1 ■ 16 C	M1.2 ■ 14 C
M2.1 ■ 15 C	M2.2 ■ 12 C	M3.1 ■ 17 E	M3.2 ■ 16 E	M3.3 ■ 5 E	M4.1 ■ 12 A	K1.1 ■ 22 G	K1.2 ■ 16 D	K1.3 ■ 12 D	K2.1 ■ 16 C	K2.2 ■ 13 C	K2.3 ■ 10 C	K3.1 ■ 14 C	K3.2 ■ 11 C
K3.3 ■ 9 C	K4.1 ■ 13 C	K4.2 ■ 10 C	K4.3 ■ 7 C	K4.4 ■ 6 C	K4.5 ■ 5 C	K5.1 ■ 15 C	K5.2 ■ 11 C	K5.3 ■ 9 C	N1.1 ■ 30 H	N1.2 ■ 23 H	N1.3 ■ 15 G	N2.1 ■ 37 F	N2.2 ■ 33 F
N2.3 ■ 24 F	N3.1 ■ 56 F	N3.2 ■ 33 G	N3.3 ■ 17 D	N4.1 ■ 30 J	N4.2 ■ 30 H	N4.3 ■ 10 F	S1.1 ■ 18 D	S1.2 ■ 10 B	S1.3 ■ 6 A	S2.1 ■ 7 C	S2.2 ■ 4 A	S3.1 ■ 5 C	S3.2 ■ 3 A
S4.1 ■ 4 C	S4.2 ■ 2 A												

DC >= 14.5mm moins de 20xD; DC > 23mm Brillant.

Produit	DC	DC	LCF	OAL	CZC MS	Produit	DC	DC	LCF	OAL	CZC MS
	(mm)	(inch)					(mm)	(mm)			
A9528.0	8.00	0.3150	210.0	330.0	MK 1	A95219.0	19.00	0.7480	310.0	465.0	MK 2
A9528.5	8.50	0.3346	210.0	330.0	MK 1	A95219.5	19.50	0.7677	325.0	490.0	MK 2
A9529.0	9.00	0.3543	220.0	345.0	MK 1	A95220.0	20.00	0.7874	325.0	490.0	MK 2
A95210.0	10.00	0.3937	235.0	360.0	MK 1	A95221.0	21.00	0.8268	325.0	490.0	MK 2
A95210.5	10.50	0.4134	235.0	360.0	MK 1	A95222.0	22.00	0.8661	345.0	515.0	MK 2
A95211.0	11.00	0.4331	250.0	375.0	MK 1	A95223.0	23.00	0.9055	345.0	515.0	MK 2
A95211.5	11.50	0.4528	250.0	375.0	MK 1	A95224.0	24.00	0.9449	365.0	555.0	MK 3
A95212.0	12.00	0.4724	260.0	395.0	MK 1	A95225.0	25.00	0.9843	365.0	555.0	MK 3
A95212.5	12.50	0.4921	260.0	395.0	MK 1	A95226.0	26.00	1.0236	365.0	555.0	MK 3
A95213.0	13.00	0.5118	260.0	395.0	MK 1	A95227.0	27.00	1.0630	385.0	580.0	MK 3
A95213.5	13.50	0.5315	275.0	410.0	MK 1	A95228.0	28.00	1.1024	385.0	580.0	MK 3
A95214.0	14.00	0.5512	275.0	410.0	MK 1	A95229.0	29.00	1.1417	385.0	580.0	MK 3
A95214.5	14.50	0.5709	275.0	425.0	MK 2	A95230.0	30.00	1.1811	385.0	580.0	MK 3
A95215.0	15.00	0.5906	275.0	425.0	MK 2	A95231.0	31.00	1.2205	410.0	610.0	MK 3
A95215.5	15.50	0.6102	295.0	445.0	MK 2	A95232.0	32.00	1.2598	410.0	635.0	MK 4
A95216.0	16.00	0.6299	295.0	445.0	MK 2	A95233.0	33.00	1.2992	410.0	635.0	MK 4
A95216.5	16.50	0.6496	295.0	445.0	MK 2	A95234.0	34.00	1.3386	430.0	665.0	MK 4
A95217.0	17.00	0.6693	295.0	445.0	MK 2	A95235.0	35.00	1.3780	430.0	665.0	MK 4
A95217.5	17.50	0.6890	310.0	465.0	MK 2	A95238.0	38.00	1.4961	460.0	695.0	MK 4
A95218.0	18.00	0.7087	310.0	465.0	MK 2	A95240.0	40.00	1.5748	460.0	695.0	MK 4
A95218.5	18.50	0.7283	310.0	465.0	MK 2						



A400



Foret étagé en HSS, finition avec traitement vapeur

Foret polyvalent conçu pour percer des trous de passage chanfreinés pour des vis à têtes fraisées métriques standard. Pointe à 118° avec chanfrein à 90°. Convient à la fois aux machines CNC et conventionnelles. La finition avec traitement vapeur retient le fluide de coupe et empêche le collage des copeaux sur l'outil. Convient pour percer de nombreux matériaux.

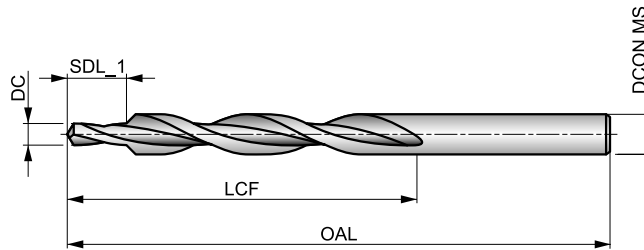

HSS	DIN 8374	4xD
90°	ST	
λ 20-35°	R	118°

Adéquation du groupe de matériaux de la pièce, valeurs de départ pour la vitesse de coupe (m/min) et code Alpha d'avance. Les tableaux d'avances par tour se trouvent à partir de la page 175.

P1.1 ■ 29 G	P1.2 ■ 33 G	P1.3 ■ 34 G	P2.1 ■ 25 G	P2.2 ■ 22 E	P2.3 ■ 19 C	P3.1 ■ 15 E	P3.2 ■ 12 E	P3.3 ■ 10 C	P4.1 ■ 9 E	P4.2 ■ 7 C	P4.3 ■ 6 C	M1.1 ■ 22 E	M1.2 ■ 19 E
M2.1 ■ 20 E	M2.2 ■ 16 E	M3.1 ■ 10 G	M3.2 ■ 9 G	M3.3 ■ 8 G	M4.1 ■ 12 C	K1.1 ■ 30 G	K1.2 ■ 22 E	K1.3 ■ 17 E	K2.1 ■ 23 E	K2.2 ■ 19 E	K2.3 ■ 15 C	K3.1 ■ 21 E	K3.2 ■ 16 E
K3.3 ■ 13 C	K4.1 ■ 19 E	K4.2 ■ 14 E	K4.3 ■ 11 C	K4.4 ■ 9 C	K4.5 ■ 8 C	K5.1 ■ 22 E	K5.2 ■ 16 E	K5.3 ■ 13 C	N1.1 ■ 45 E	N1.2 ■ 34 E	N1.3 ■ 23 E	N2.1 ■ 49 E	N2.2 ■ 44 E
N2.3 ■ 32 E	N3.1 ■ 68 E	N3.2 ■ 40 E	N3.3 ■ 20 E	N4.1 ■ 30 I	S1.1 ■ 23 E	S1.2 ■ 14 C	S1.3 ■ 8 A	S2.1 ■ 8 C	S2.2 ■ 6 A	S3.1 ■ 6 C	S3.2 ■ 4 A	S4.1 ■ 5 C	S4.2 ■ 3 A

Produit	TDZ	DC	DC	LCF	OAL	SDL_1	DCON MS
		(mm)	(inch)				
A400M3	M3	3.20	0.1260	57.0	93.0	9.00	6.00
A400M4	M4	4.30	0.1693	75.0	117.0	11.00	8.00
A400M5	M5	5.30	0.2087	87.0	133.0	13.00	10.00
A400M6	M6	6.40	0.2520	94.0	142.0	15.00	11.50
A400M8	M8	8.40	0.3307	114.0	169.0	19.00	15.00
A400M10	M10	10.50	0.4134	135.0	198.0	23.00	19.00



A402

Foret étagé en HSS, finition avec traitement vapeur

Foret polyvalent recommandé pour percer des trous de passage lamés pour les vis CHC métriques standard. Pointe à 118° avec épaulement à 180°. La finition avec traitement vapeur retient le fluide de coupe et empêche le collage des copeaux sur l'outil. Convient pour percer de nombreux matériaux.

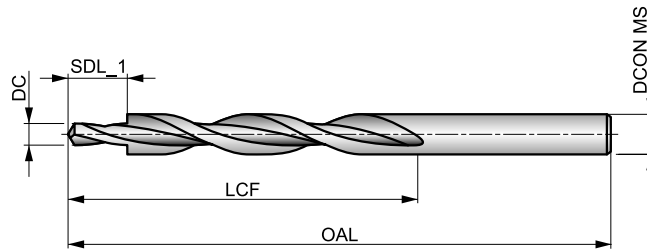

HSS	DIN 8376	4xD
180°	ST	
λ 20-35°	R	118°

Adéquation du groupe de matériaux de la pièce, valeurs de départ pour la vitesse de coupe (m/min) et code Alpha d'avance. Les tableaux d'avances par tour se trouvent à partir de la page 175.

P1.1 ■ 29 G	P1.2 ■ 33 G	P1.3 ■ 34 G	P2.1 ■ 25 G	P2.2 ■ 22 E	P2.3 ■ 19 C	P3.1 ■ 15 E	P3.2 ■ 12 E	P3.3 ■ 10 C	P4.1 ■ 9 E	P4.2 ■ 17 C	P4.3 ■ 6 C	M1.1 ■ 22 E	M1.2 ■ 19 E
M2.1 ■ 20 E	M2.2 ■ 16 E	M3.1 ■ 10 G	M3.2 ■ 9 G	M3.3 ■ 8 G	M4.1 ■ 12 C	K1.1 ■ 30 G	K1.2 ■ 22 E	K1.3 ■ 17 E	K2.1 ■ 23 E	K2.2 ■ 19 E	K2.3 ■ 15 C	K3.1 ■ 21 E	K3.2 ■ 16 E
K3.3 ■ 13 C	K4.1 ■ 19 E	K4.2 ■ 14 E	K4.3 ■ 11 C	K4.4 ■ 9 C	K4.5 ■ 8 C	K5.1 ■ 22 E	K5.2 ■ 16 E	K5.3 ■ 13 C	N1.1 ■ 45 E	N1.2 ■ 34 E	N1.3 ■ 23 E	N2.1 ■ 49 E	N2.2 ■ 44 E
N2.3 ■ 32 E	N3.1 ■ 68 E	N3.2 ■ 40 E	N3.3 ■ 20 E	N4.1 ■ 30 I	S1.1 ■ 23 E	S1.2 ■ 14 C	S1.3 ■ 8 A	S2.1 ■ 8 C	S2.2 ■ 6 A	S3.1 ■ 6 C	S3.2 ■ 4 A	S4.1 ■ 5 C	S4.2 ■ 3 A

Produit	TDZ	DC	DC	LCF	OAL	SDL_1	DCON MS
		(mm)	(inch)				
A402M3	M3	3.40	0.1339	57.0	93.0	9.00	6.00
A402M4	M4	4.50	0.1772	75.0	117.0	11.00	8.00
A402M5	M5	5.50	0.2165	87.0	133.0	13.00	10.00
A402M6	M6	6.60	0.2598	94.0	142.0	15.00	11.00
A402M8	M8	9.00	0.3543	114.0	169.0	19.00	15.00
A402M10	M10	11.00	0.4331	130.0	191.0	23.00	18.00



A405



Foret étagé à queue cône morse en HSS, finition avec traitement vapeur

Foret polyvalent recommandé pour percer des trous de passage lamés pour les vis CHC métriques standard. Pointe à 118° avec épaulement à 180°. Convient à la fois aux machines CNC et conventionnelles. La finition avec traitement vapeur retient le fluide de coupe et empêche le collage des copeaux sur l'outil. Convient pour percer de nombreux matériaux.

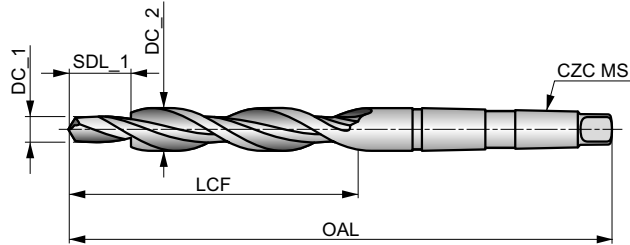

HSS	DIN 8377	4xD
180°	ST	
λ 20-35°	R	118°

Adéquation du groupe de matériaux de la pièce, valeurs de départ pour la vitesse de coupe (m/min) et code Alpha d'avance. Les tableaux d'avances par tour se trouvent à partir de la page 175.

P1.1 ■ 29 G	P1.2 ■ 33 G	P1.3 ■ 34 G	P2.1 ■ 25 G	P2.2 ■ 22 E	P2.3 ■ 19 C	P3.1 ■ 15 E	P3.2 ■ 12 E	P3.3 ■ 10 C	P4.1 ■ 9 E	P4.2 ■ 7 C	P4.3 ■ 6 C	M1.1 ■ 22 E	M1.2 ■ 19 E
M2.1 ■ 20 E	M2.2 ■ 16 E	M3.1 ■ 10 G	M3.2 ■ 9 G	M3.3 ■ 8 G	M4.1 ■ 12 C	K1.1 ■ 30 G	K1.2 ■ 22 E	K1.3 ■ 17 E	K2.1 ■ 23 E	K2.2 ■ 19 E	K2.3 ■ 15 C	K3.1 ■ 21 E	K3.2 ■ 16 E
K3.3 ■ 13 C	K4.1 ■ 19 E	K4.2 ■ 14 E	K4.3 ■ 11 C	K4.4 ■ 9 C	K4.5 ■ 8 C	K5.1 ■ 22 E	K5.2 ■ 16 E	K5.3 ■ 13 C	N1.1 ■ 45 E	N1.2 ■ 34 E	N1.3 ■ 23 E	N2.1 ■ 49 E	N2.2 ■ 44 E
N2.3 ■ 32 E	N3.1 ■ 68 E	N3.2 ■ 40 E	N3.3 ■ 20 E	N4.1 ■ 30 I	S1.1 ■ 23 E	S1.2 ■ 14 C	S1.3 ■ 8 A	S2.1 ■ 8 C	S2.2 ■ 6 A	S3.1 ■ 6 C	S3.2 ■ 4 A	S4.1 ■ 5 C	S4.2 ■ 3 A

Produit	TDZ	DC_1	DC_1	DC_2	LCF	OAL	SDL_1	CZC MS
		(mm)	(inch)	(mm)	(mm)	(mm)	(mm)	
A405M6	M6	6.60	0.2598	11.00	94.0	175.0	15.00	MK 1
A405M8	M8	9.00	0.3543	15.00	114.0	212.0	19.00	MK 2
A405M10	M10	11.00	0.4331	18.00	130.0	228.0	23.00	MK 2
A405M12	M12	13.50	0.5315	20.00	140.0	238.0	27.00	MK 2
A405M14	M14	15.50	0.6102	24.00	160.0	281.0	31.00	MK 3
A405M16	M16	17.50	0.6890	26.00	165.0	286.0	35.00	MK 3
A405M18	M18	20.00	0.7874	30.00	175.0	296.0	39.00	MK 3



A412



Foret étagé en HSS, finition avec traitement vapeur

Foret conçu pour percer des trous de passage chanfreinés pour des vis à têtes fraisées métriques standard. Un angle de pointe de 118° sur le pilote de forage avec un chanfrein de 90°. La finition avec traitement vapeur retient le fluide de coupe et empêche le collage des copeaux sur l'outil. Convient pour percer de nombreux matériaux. Il convient aux machines CNC et conventionnelles.

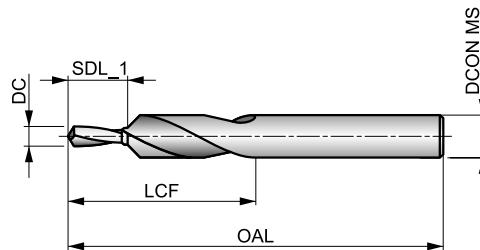

HSS	DORMER	2.5×D
90°	ST	
R	118°	

Adéquation du groupe de matériaux de la pièce, valeurs de départ pour la vitesse de coupe (m/min) et code Alpha d'avance. Les tableaux d'avances par tour se trouvent à partir de la page 175.

P1.1 ■ 29 I	P1.2 ■ 33 I	P1.3 ■ 34 I	P2.1 ■ 25 I	P2.2 ■ 22 G	P2.3 ■ 19 E	P3.1 ■ 15 G	P3.2 ■ 12 G	P3.3 ■ 10 E	P4.1 ■ 9 G	P4.2 ■ 7 E	P4.3 ■ 6 C	M1.1 ■ 22 G	M1.2 ■ 19 G
M2.1 ■ 20 G	M2.2 ■ 16 G	M3.1 ■ 10 I	M3.2 ■ 9 I	M3.3 ■ 8 I	M4.1 ■ 12 E	K1.1 ■ 30 G	K1.2 ■ 22 E	K1.3 ■ 17 E	K2.1 ■ 23 E	K2.2 ■ 19 E	K2.3 ■ 15 E	K3.1 ■ 21 E	K3.2 ■ 16 E
K3.3 ■ 13 E	K4.1 ■ 19 E	K4.2 ■ 14 E	K4.3 ■ 11 E	K4.4 ■ 9 E	K4.5 ■ 8 E	K5.1 ■ 22 E	K5.2 ■ 16 E	K5.3 ■ 13 E	N1.1 ■ 45 G	N1.2 ■ 34 G	N1.3 ■ 23 G	N2.1 ■ 42 G	N2.2 ■ 37 G
N2.3 ■ 27 G	N3.1 ■ 68 G	N3.2 ■ 40 G	N3.3 ■ 20 G	N4.1 ■ 30 I	S1.1 ■ 27 G	S1.2 ■ 16 E	S1.3 ■ 8 C	S2.1 ■ 11 G	S2.2 ■ 6 C	S3.1 ■ 8 G	S3.2 ■ 4 C	S4.1 ■ 6 G	S4.2 ■ 3 C

Produit	TDZ	DC	DC	LCF	OAL	SDL_1	DCON MS
		(mm)	(inch)				
A412M3	M3	3.40	0.1339	31.0	70.0	9.00	6.60
A412M4	M4	4.50	0.1772	40.0	84.0	11.00	9.00
A412M5	M5	5.50	0.2165	47.0	95.0	13.00	11.00
A412M6	M6	6.60	0.2598	51.0	102.0	15.00	13.00
A412M8	M8	9.00	0.3543	62.0	123.0	19.00	17.20
A412M10	M10	11.00	0.4331	70.0	141.0	23.00	21.50



A413



Foret étagé en HSS, finition avec traitement vapeur

Foret polyvalent recommandé pour percer des trous de passage lamés pour les vis CHC métriques standard. Pointe à 118° avec épaulement à 180°. La finition avec traitement vapeur retient le fluide de coupe et empêche le collage des copeaux sur l'outil. Convient à la fois aux machines CNC et conventionnelles. Convient pour percer de nombreux matériaux.

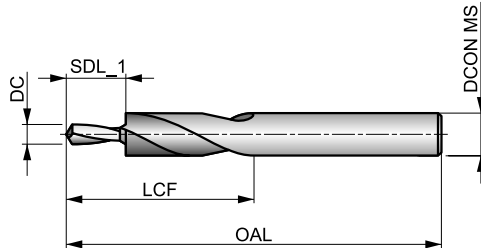

HSS	DORMER	2.5xD
180°	ST	
R	118°	

Adéquation du groupe de matériaux de la pièce, valeurs de départ pour la vitesse de coupe (m/min) et code Alpha d'avance. Les tableaux d'avances par tour se trouvent à partir de la page 175.

P1.1 ■ 29 I	P1.2 ■ 33 I	P1.3 ■ 34 I	P2.1 ■ 25 I	P2.2 ■ 22 G	P2.3 ■ 19 E	P3.1 ■ 15 G	P3.2 ■ 12 G	P3.3 ■ 10 E	P4.1 ■ 9 G	P4.2 ■ 7 E	P4.3 ■ 6 C	M1.1 ■ 22 G	M1.2 ■ 19 G
M2.1 ■ 20 G	M2.2 ■ 16 G	M3.1 ■ 10 I	M3.2 ■ 9 I	M3.3 ■ 8 I	M4.1 ■ 12 E	K1.1 ■ 30 G	K1.2 ■ 22 E	K1.3 ■ 17 E	K2.1 ■ 23 E	K2.2 ■ 19 E	K2.3 ■ 15 E	K3.1 ■ 21 E	K3.2 ■ 16 E
K3.3 ■ 13 E	K4.1 ■ 19 E	K4.2 ■ 14 E	K4.3 ■ 11 E	K4.4 ■ 9 E	K4.5 ■ 8 E	K5.1 ■ 22 E	K5.2 ■ 16 E	K5.3 ■ 13 E	N1.1 ■ 45 G	N1.2 ■ 34 G	N1.3 ■ 23 G	N2.1 ■ 42 G	N2.2 ■ 37 G
N2.3 ■ 27 G	N3.1 ■ 68 G	N3.2 ■ 40 G	N3.3 ■ 20 G	N4.1 ■ 30 I	S1.1 ■ 27 G	S1.2 ■ 16 E	S1.3 ■ 8 C	S2.1 ■ 11 G	S2.2 ■ 6 C	S3.1 ■ 8 G	S3.2 ■ 4 C	S4.1 ■ 6 G	S4.2 ■ 3 C

Produit	TDZ	DC	DC	LCF	OAL	SDL_1	DCON MS
		(mm)	(inch)				
A413M3	M3	3.40	0.1339	28.0	66.0	9.00	6.00
A413M4	M4	4.50	0.1772	37.0	79.0	11.00	8.00
A413M5	M5	5.50	0.2165	43.0	89.0	13.00	10.00
A413M6	M6	6.60	0.2598	47.0	95.0	15.00	11.00
A413M8	M8	9.00	0.3543	56.0	111.0	19.00	15.00
A413M10	M10	11.00	0.4331	62.0	123.0	23.00	18.00



A200



Foret à centrer en HSS avec pointe à 118° et chanfrein à 60°, finition brillante

Foret à centrer avec deux extrémités de perçage qui permettent d'augmenter la productivité par outil. Convient à de nombreux matériaux.

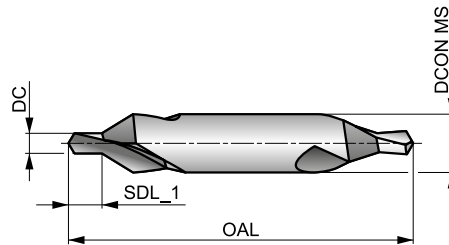

HSS	DIN 333A	1×D
60°	Bright	
R	118°	

Adéquation du groupe de matériaux de la pièce, valeurs de départ pour la vitesse de coupe (m/min) et code Alpha d'avance. Les tableaux d'avances par tour se trouvent à partir de la page 175.

P1.1 ■ 33 I	P1.2 ■ 37 I	P1.3 ■ 38 I	P2.1 ■ 28 I	P2.2 ■ 25 G	P2.3 ■ 22 E	P3.1 ■ 19 F	P3.2 ■ 15 F	P3.3 ■ 13 E	P4.1 ■ 11 F	P4.2 ■ 10 E	P4.3 ■ 8 D	M1.1 ■ 21 E	M1.2 ■ 17 E
M2.1 ■ 18 E	M2.2 ■ 15 E	M3.1 ■ 9 G	M3.2 ■ 8 G	M3.3 ■ 7 G	M4.1 ■ 10 C	K1.1 ■ 30 I	K1.2 ■ 22 F	K1.3 ■ 17 F	K2.1 ■ 25 E	K2.2 ■ 20 E	K2.3 ■ 16 E	K3.1 ■ 22 E	K3.2 ■ 17 E
K3.3 ■ 13 E	K4.1 ■ 20 E	K4.2 ■ 15 E	K4.3 ■ 11 E	K4.4 ■ 10 E	K4.5 ■ 8 E	K5.1 ■ 23 E	K5.2 ■ 17 E	K5.3 ■ 13 E	N1.1 ■ 33 J	N1.2 ■ 25 J	N1.3 ■ 17 I	N2.1 ■ 42 H	N2.2 ■ 37 H
N2.3 ■ 27 H	N3.1 ■ 56 H	N3.2 ■ 33 I	N3.3 ■ 17 G	N4.1 ■ 30 J	N4.2 ■ 28 H	N4.3 ■ 14 F	S1.1 ■ 24 F	S1.2 ■ 13 D	S1.3 ■ 7 B	S2.1 ■ 7 E	S2.2 ■ 6 A	S3.1 ■ 5 E	S3.2 ■ 4 A
S4.1 ■ 4 E	S4.2 ■ 3 A												

Les produits de cette série sont également disponibles en coffret. Voir A296.

Produit	DC	DC	SDL_1	OAL	DCON MS
	(mm)	(inch)	(mm)	(mm)	(mm)
A200.5X3.15 ¹⁾	0.50	0.0197	0.9 - 0.6	25.0	3.15
A200.8X3.15 ¹⁾	0.80	0.0315	1.3 - 1.0	25.0	3.15
A2001.0X3.15	1.00	0.0394	1.7 - 1.3	31.0	3.15
A2001.25X3.15	1.25	0.0492	2.0 - 1.6	31.0	3.15
A2001.6X4.0	1.60	0.0630	2.6 - 2.0	35.0	4.00
A2002.0X5.0	2.00	0.0787	3.1 - 2.5	40.0	5.00
A2002.5X6.3	2.50	0.0984	3.8 - 3.1	45.0	6.30
A2003.15X8.0	3.15	0.1240	4.6 - 3.9	50.0	8.00
A2004.0X10.0	4.00	0.1575	5.9 - 5.0	55.0	10.00
A2005.0X12.5	5.00	0.1969	7.2 - 6.3	63.0	12.50
A2006.3X16.0	6.30	0.2480	8.9 - 8.0	71.0	16.00
A2008.0X20.0	8.00	0.3150	11.1 - 10.1	80.0	20.00
A20010.0X25.0	10.00	0.3937	13.8 - 12.8	100.0	25.00
A20012.5X31.5	12.50	0.4921	17.5 - 16.5	125.0	31.50

¹⁾ Une seule pointe.



A205



Foret à centrer en HSS avec pointe à 118° et chanfrein à 60°, revêtement TiN

Foret à centrer avec deux extrémités de perçage qui permettent d'augmenter la productivité par outil. Le revêtement TiN améliore les performances et prolonge la durée de vie de l'outil. Convient pour le perçage de nombreux matériaux.

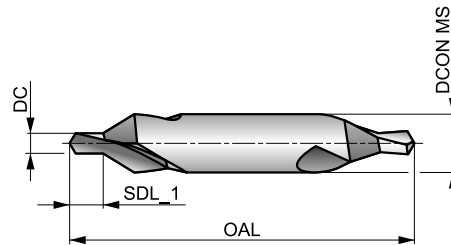

HSS	DIN 333A	1xD
60°	TiN	
R	118°	

Adéquation du groupe de matériaux de la pièce, valeurs de départ pour la vitesse de coupe (m/min) et code Alpha d'avance. Les tableaux d'avances par tour se trouvent à partir de la page 175.

P1.1 ■ 40 I	P1.2 ■ 45 I	P1.3 ■ 46 I	P2.1 ■ 34 I	P2.2 ■ 30 G	P2.3 ■ 27 E	P3.1 ■ 24 F	P3.2 ■ 19 F	P3.3 ■ 16 E	P4.1 ■ 14 F	P4.2 ■ 12 E	P4.3 ■ 10 D	M1.1 ■ 25 E	M1.2 ■ 21 E
M2.1 ■ 22 E	M2.2 ■ 18 E	M3.1 ■ 12 G	M3.2 ■ 10 G	M3.3 ■ 9 G	M4.1 ■ 12 C	K1.1 ■ 36 I	K1.2 ■ 27 F	K1.3 ■ 20 F	K2.1 ■ 30 E	K2.2 ■ 24 E	K2.3 ■ 19 E	K3.1 ■ 26 E	K3.2 ■ 20 E
K3.3 ■ 16 E	K4.1 ■ 24 E	K4.2 ■ 18 E	K4.3 ■ 13 E	K4.4 ■ 11 E	K4.5 ■ 10 E	K5.1 ■ 27 E	K5.2 ■ 21 E	K5.3 ■ 16 E	N1.1 ■ 40 J	N1.2 ■ 30 J	N1.3 ■ 20 I	N2.1 ■ 49 H	N2.2 ■ 44 H
N2.3 ■ 32 H	N3.1 ■ 68 H	N3.2 ■ 40 I	N3.3 ■ 20 G	N4.1 ■ 36 J	N4.2 ■ 34 H	N4.3 ■ 17 F	S1.1 ■ 29 F	S1.2 ■ 16 D	S1.3 ■ 8 B	S2.1 ■ 8 E	S2.2 ■ 7 A	S3.1 ■ 6 E	S3.2 ■ 5 A
S4.1 ■ 5 E	S4.2 ■ 4 A												

Produit	DC	DC	SDL_1	OAL	DCON MS
	(mm)	(inch)	(mm)	(mm)	(mm)
A2051.0X3.15	1.00	0.0394	1.7 - 1.3	31.0	3.15
A2051.25X3.15	1.25	0.0492	2.0 - 1.6	31.0	3.15
A2051.6X4.0	1.60	0.0630	2.6 - 2.0	35.0	4.00
A2052.0X5.0	2.00	0.0787	3.1 - 2.5	40.0	5.00
A2052.5X6.3	2.50	0.0984	3.8 - 3.1	45.0	6.30
A2053.15X8.0	3.15	0.1240	4.6 - 3.9	50.0	8.00
A2054.0X10.0	4.00	0.1575	5.9 - 5.0	55.0	10.00
A2055.0X12.5	5.00	0.1969	7.2 - 6.3	63.0	12.50



A206



Foret à centrer en HSS-E avec pointe à 118° et chanfrein à 60°, finition brillante

Foret à centrer avec deux extrémités de perçage qui permettent d'augmenter la productivité par outil. Convient pour le perçage de nombreux matériaux.

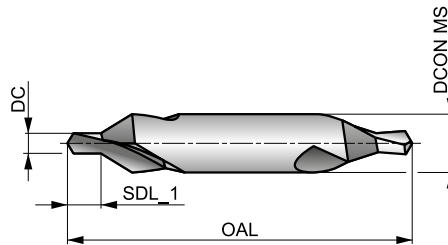

HSS-E	DIN 333A	1xD
60°	Bright	
R	118°	

Adéquation du groupe de matériaux de la pièce, valeurs de départ pour la vitesse de coupe (m/min) et code Alpha d'avance. Les tableaux d'avances par tour se trouvent à partir de la page 175.

P1.1 ■ 40 I	P1.2 ■ 45 I	P1.3 ■ 46 I	P2.1 ■ 34 I	P2.2 ■ 30 G	P2.3 ■ 27 E	P3.1 ■ 24 F	P3.2 ■ 19 F	P3.3 ■ 16 E	P4.1 ■ 14 F	P4.2 ■ 12 E	P4.3 ■ 10 D	M1.1 ■ 25 E	M1.2 ■ 21 E
M2.1 ■ 22 E	M2.2 ■ 18 E	M3.1 ■ 12 G	M3.2 ■ 10 G	M3.3 ■ 9 G	M4.1 ■ 12 C	K1.1 ■ 36 I	K1.2 ■ 27 F	K1.3 ■ 20 F	K2.1 ■ 30 E	K2.2 ■ 24 E	K2.3 ■ 19 E	K3.1 ■ 26 E	K3.2 ■ 20 E
K3.3 ■ 16 E	K4.1 ■ 24 E	K4.2 ■ 18 E	K4.3 ■ 13 E	K4.4 ■ 11 E	K4.5 ■ 10 E	K5.1 ■ 27 E	K5.2 ■ 21 E	K5.3 ■ 16 E	N1.1 ■ 40 J	N1.2 ■ 30 J	N1.3 ■ 20 I	N2.1 ■ 49 H	N2.2 ■ 44 H
N2.3 ■ 32 H	N3.1 ■ 68 H	N3.2 ■ 40 I	N3.3 ■ 20 G	N4.1 ■ 36 J	N4.2 ■ 34 H	N4.3 ■ 17 F	S1.1 ■ 29 F	S1.2 ■ 16 D	S1.3 ■ 8 B	S2.1 ■ 8 E	S2.2 ■ 7 A	S3.1 ■ 6 E	S3.2 ■ 5 A
S4.1 ■ 5 E	S4.2 ■ 4 A												

Produit	DC	DC	SDL_1	OAL	DCON MS
	(mm)	(inch)			
A2061.0X3.15	1.00	0.0394	1.7 - 1.3	31.0	3.15
A2061.25X3.15	1.25	0.0492	2.0 - 1.6	31.0	3.15
A2061.6X4.0	1.60	0.0630	2.6 - 2.0	35.0	4.00
A2062.0X5.0	2.00	0.0787	3.1 - 2.5	40.0	5.00
A2062.5X6.3	2.50	0.0984	3.8 - 3.1	45.0	6.30
A2063.15X8.0	3.15	0.1240	4.6 - 3.9	50.0	8.00
A2064.0X10.0	4.00	0.1575	5.9 - 5.0	55.0	10.00
A2065.0X12.5	5.00	0.1969	7.2 - 6.3	63.0	12.50



A266

DORMER

Foret à centrer en HSS-E avec pointe à 118° et chanfrein à 60°, revêtement TiAlN

Foret à centrer avec deux extrémités de perçage qui permettent d'augmenter la productivité par outil. Le revêtement TiAlN améliore les performances et prolonge la durée de vie de l'outil. Convient pour le perçage de nombreux matériaux.

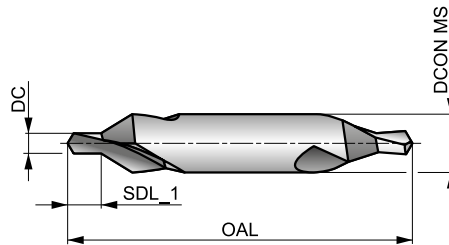

HSS-E	DIN 333A	1xD
60°	TiAlN	
R	118°	

Adéquation du groupe de matériaux de la pièce, valeurs de départ pour la vitesse de coupe (m/min) et code Alpha d'avance. Les tableaux d'avances par tour se trouvent à partir de la page 175.

P1.1 ■ 40 I	P1.2 ■ 45 I	P1.3 ■ 46 I	P2.1 ■ 34 I	P2.2 ■ 30 G	P2.3 ■ 27 E	P3.1 ■ 24 F	P3.2 ■ 19 F	P3.3 ■ 16 E	P4.1 ■ 14 F	P4.2 ■ 12 E	P4.3 ■ 10 D	M1.1 ■ 25 E	M1.2 ■ 21 E
M2.1 ■ 22 E	M2.2 ■ 18 E	M3.1 ■ 12 G	M3.2 ■ 10 G	M3.3 ■ 9 G	M4.1 ■ 12 C	K1.1 ■ 36 I	K1.2 ■ 27 F	K1.3 ■ 20 F	K2.1 ■ 30 E	K2.2 ■ 24 E	K2.3 ■ 19 E	K3.1 ■ 26 E	K3.2 ■ 20 E
K3.3 ■ 16 E	K4.1 ■ 24 E	K4.2 ■ 18 E	K4.3 ■ 13 E	K4.4 ■ 11 E	K4.5 ■ 10 E	K5.1 ■ 27 E	K5.2 ■ 21 E	K5.3 ■ 16 E	N1.1 ■ 40 J	N1.2 ■ 30 J	N1.3 ■ 20 I	N2.1 ■ 49 H	N2.2 ■ 44 H
N2.3 ■ 32 H	N3.1 ■ 68 H	N3.2 ■ 40 I	N3.3 ■ 20 G	N4.1 ■ 36 J	N4.2 ■ 34 H	N4.3 ■ 17 F	S1.1 ■ 29 F	S1.2 ■ 16 D	S1.3 ■ 8 B	S2.1 ■ 8 E	S2.2 ■ 7 A	S3.1 ■ 6 E	S3.2 ■ 5 A
S4.1 ■ 5 E	S4.2 ■ 4 A												

Produit	DC	DC	SDL_1	OAL	DCON MS
	(mm)	(inch)	(mm)	(mm)	(mm)
A2661.0X3.15	1.00	0.0394	1.7 - 1.3	31.0	3.15
A2661.25X3.15	1.25	0.0492	2.0 - 1.6	31.0	3.15
A2661.6X4.0	1.60	0.0630	2.6 - 2.0	35.0	4.00
A2662.0X5.0	2.00	0.0787	3.1 - 2.5	40.0	5.00
A2662.5X6.3	2.50	0.0984	3.8 - 3.1	45.0	6.30
A2663.15X8.0	3.15	0.1240	4.6 - 3.9	50.0	8.00
A2664.0X10.0	4.00	0.1575	5.9 - 5.0	55.0	10.00
A2665.0X12.5	5.00	0.1969	7.2 - 6.3	63.0	12.50



A210

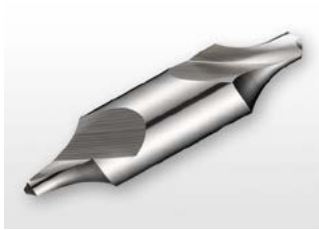

Foret à centrer en HSS avec pointe à 118° et chanfrein concave, finition brillante

Foret à centrer avec deux extrémités de perçage qui permettent d'augmenter la productivité par outil. Peut être utilisé pour usiner un certain nombre de matériaux.

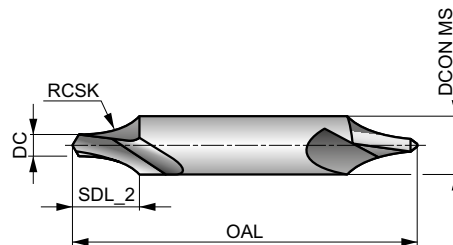

HSS	DIN 333R	1xD
R	Bright	
R	118°	

Adéquation du groupe de matériaux de la pièce, valeurs de départ pour la vitesse de coupe (m/min) et code Alpha d'avance. Les tableaux d'avances par tour se trouvent à partir de la page 175.

P1.1 ■ 33 I	P1.2 ■ 37 I	P1.3 ■ 38 I	P2.1 ■ 28 I	P2.2 ■ 25 G	P2.3 ■ 22 E	P3.1 ■ 19 F	P3.2 ■ 15 F	P3.3 ■ 13 E	P4.1 ■ 11 F	P4.2 ■ 10 E	P4.3 ■ 8 D	M1.1 ■ 21 E	M1.2 ■ 17 E
M2.1 ■ 18 E	M2.2 ■ 15 E	M3.1 ■ 9 G	M3.2 ■ 8 G	M3.3 ■ 7 G	M4.1 ■ 10 C	K1.1 ■ 30 I	K1.2 ■ 22 F	K1.3 ■ 17 F	K2.1 ■ 25 E	K2.2 ■ 20 E	K2.3 ■ 16 E	K3.1 ■ 22 E	K3.2 ■ 17 E
K3.3 ■ 13 E	K4.1 ■ 20 E	K4.2 ■ 15 E	K4.3 ■ 11 E	K4.4 ■ 10 E	K4.5 ■ 8 E	K5.1 ■ 23 E	K5.2 ■ 17 E	K5.3 ■ 13 E	N1.1 ■ 33 J	N1.2 ■ 25 J	N1.3 ■ 17 I	N2.1 ■ 42 H	N2.2 ■ 37 H
N2.3 ■ 27 H	N3.1 ■ 56 H	N3.2 ■ 33 I	N3.3 ■ 17 G	N4.1 ■ 30 J	N4.2 ■ 28 H	N4.3 ■ 14 F	S1.1 ■ 24 F	S1.2 ■ 13 D	S1.3 ■ 7 B	S2.1 ■ 7 E	S2.2 ■ 6 A	S3.1 ■ 5 E	S3.2 ■ 4 A
S4.1 ■ 4 E	S4.2 ■ 3 A												

Produit	DC	DC	SDL_2	OAL	RCSK	DCON MS
	(mm)	(inch)	(mm)	(mm)	(mm)	(mm)
A210.5X3.15 ¹⁾	0.50	0.0197	2.6 - 2.3	25.0	2.50 - 2.00	3.15
A210.8X3.15 ¹⁾	0.80	0.0315	2.9 - 2.6	25.0	3.15 - 2.50	3.15
A2101.0X3.15	1.00	0.0394	3.3 - 3.0	31.0	3.65 - 2.90	3.15
A2101.25X3.15	1.25	0.0492	3.6 - 3.3	31.0	3.95 - 3.15	3.15
A2101.6X4.0	1.60	0.0630	4.7 - 4.2	35.0	5.00 - 4.00	4.00
A2102.0X5.0	2.00	0.0787	5.4 - 5.0	40.0	6.25 - 5.00	5.00
A2102.5X6.3	2.50	0.0984	6.8 - 6.3	45.0	7.88 - 6.30	6.30
A2103.15X8.0	3.15	0.1240	8.5 - 8.0	50.0	10.00 - 8.00	8.00
A2104.0X10.0	4.00	0.1575	10.6 - 10.0	55.0	12.50 - 10.00	10.00
A2105.0X12.5	5.00	0.1969	13.1 - 12.5	63.0	15.63 - 12.50	12.50
A2106.3X16.0	6.30	0.2480	16.6 - 16.0	71.0	20.00 - 16.00	16.00
A2108.0X20.0	8.00	0.3150	20.7 - 20.0	80.0	25.00 - 20.00	20.00
A21010.0X25.0	10.00	0.3937	25.7 - 25.0	100.0	31.25 - 25.00	25.00

¹⁾ Une seule pointe.



A201

DORMER



Foret à centrer en HSS avec pointe à 122° et chanfrein à 60°, finition brillante

Foret à centrer avec deux extrémités de perçage qui permettent d'augmenter la productivité par outil. Convient pour le perçage de nombreux matériaux.

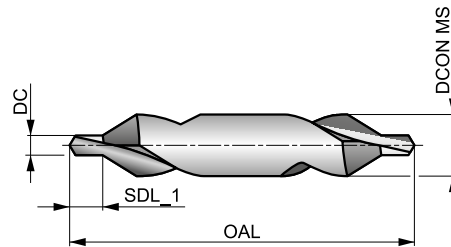

HSS	DORMER	1xD
60°	Bright	
R	122°	

Adéquation du groupe de matériaux de la pièce, valeurs de départ pour la vitesse de coupe (m/min) et code Alpha d'avance. Les tableaux d'avances par tour se trouvent à partir de la page 175.

P1.1 ■ 33 I	P1.2 ■ 37 I	P1.3 ■ 38 I	P2.1 ■ 28 I	P2.2 ■ 25 G	P2.3 ■ 22 E	P3.1 ■ 19 F	P3.2 ■ 15 F	P3.3 ■ 13 E	P4.1 ■ 11 F	P4.2 ■ 10 E	P4.3 ■ 8 D	M1.1 ■ 21 E	M1.2 ■ 17 E
M2.1 ■ 18 E	M2.2 ■ 15 E	M3.1 ■ 9 G	M3.2 ■ 8 G	M3.3 ■ 7 G	M4.1 ■ 10 C	K1.1 ■ 30 I	K1.2 ■ 22 F	K1.3 ■ 17 F	K2.1 ■ 25 E	K2.2 ■ 20 E	K2.3 ■ 16 E	K3.1 ■ 22 E	K3.2 ■ 17 E
K3.3 ■ 13 E	K4.1 ■ 20 E	K4.2 ■ 15 E	K4.3 ■ 11 E	K4.4 ■ 10 E	K4.5 ■ 8 E	K5.1 ■ 23 E	K5.2 ■ 17 E	K5.3 ■ 13 E	N1.1 ■ 33 J	N1.2 ■ 25 J	N1.3 ■ 17 I	N2.1 ■ 42 H	N2.2 ■ 37 H
N2.3 ■ 27 H	N3.1 ■ 56 H	N3.2 ■ 33 I	N3.3 ■ 17 G	N4.1 ■ 30 J	N4.2 ■ 28 H	N4.3 ■ 14 F	S1.1 ■ 24 F	S1.2 ■ 13 D	S1.3 ■ 7 B	S2.1 ■ 7 E	S2.2 ■ 6 A	S3.1 ■ 5 E	S3.2 ■ 4 A
S4.1 ■ 4 E	S4.2 ■ 3 A												

Produit	DC	DC	SDL_1	OAL	DCON MS
	(mm)	(inch)	(mm)	(mm)	(mm)
A201.63X3.15 ¹⁾	0.63	0.0248	1.2 - 0.9	20.0	3.15
A201.75X3.5	0.75	0.0295	1.3 - 1.0	35.0	3.50
A2011.0X4.0	1.00	0.0394	2.1 - 1.5	35.0	4.00
A2011.5X5.0	1.50	0.0591	2.8 - 2.0	40.0	5.00
A2011.6X5.0	1.60	0.0630	2.4 - 2.0	40.0	5.00
A2012.0X6.0	2.00	0.0787	4.0 - 3.0	45.0	6.00
A2012.0X6.3	2.00	0.0787	2.9 - 2.5	45.0	6.30
A2012.5X8.0	2.50	0.0984	4.5 - 3.5	50.0	8.00
A2013.0X8.0	3.00	0.1181	4.4 - 3.9	50.0	8.00
A2013.0X10.0	3.00	0.1181	5.0 - 4.0	56.0	10.00
A2013.15X10.0	3.15	0.1240	4.4 - 3.9	56.0	10.00
A2014.0X12.0	4.00	0.1575	6.2 - 5.0	66.0	12.00
A2015.0X14.0	5.00	0.1969	7.7 - 6.5	78.0	14.00
A2016.0X18.0	6.00	0.2362	9.2 - 8.0	90.0	18.00

¹⁾ Une seule pointe.



A225

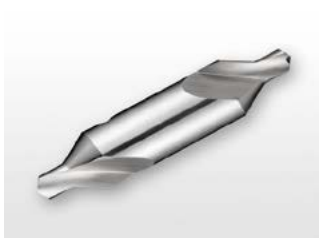

Foret à centrer en HSS avec pointe à 120° et chanfrein à 60°, finition brillante

Foret à centrer à la norme britannique 328 avec deux extrémités de perçage qui permettent d'augmenter la productivité par outil. Convient pour le perçage de nombreux matériaux.

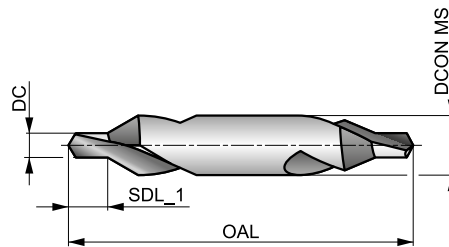

HSS	BS 328	1×D
60°	Bright	
R	120°	

Adéquation du groupe de matériaux de la pièce, valeurs de départ pour la vitesse de coupe (m/min) et code Alpha d'avance. Les tableaux d'avances par tour se trouvent à partir de la page 175.

P1.1 ■ 33 I	P1.2 ■ 37 I	P1.3 ■ 38 I	P2.1 ■ 28 I	P2.2 ■ 25 G	P2.3 ■ 22 E	P3.1 ■ 19 F	P3.2 ■ 15 F	P3.3 ■ 13 E	P4.1 ■ 11 F	P4.2 ■ 10 E	P4.3 ■ 8 D	M1.1 ■ 21 E	M1.2 ■ 17 E
M2.1 ■ 18 E	M2.2 ■ 15 E	M3.1 ■ 9 G	M3.2 ■ 8 G	M3.3 ■ 7 G	M4.1 ■ 10 C	K1.1 ■ 30 I	K1.2 ■ 22 F	K1.3 ■ 17 F	K2.1 ■ 25 E	K2.2 ■ 20 E	K2.3 ■ 16 E	K3.1 ■ 22 E	K3.2 ■ 17 E
K3.3 ■ 13 E	K4.1 ■ 20 E	K4.2 ■ 15 E	K4.3 ■ 11 E	K4.4 ■ 10 E	K4.5 ■ 8 E	K5.1 ■ 23 E	K5.2 ■ 17 E	K5.3 ■ 13 E	N1.1 ■ 33 J	N1.2 ■ 25 J	N1.3 ■ 17 I	N2.1 ■ 42 H	N2.2 ■ 37 H
N2.3 ■ 27 H	N3.1 ■ 56 H	N3.2 ■ 33 I	N3.3 ■ 17 G	N4.1 ■ 30 J	N4.2 ■ 28 H	N4.3 ■ 14 F	S1.1 ■ 24 F	S1.2 ■ 13 D	S1.3 ■ 7 B	S2.1 ■ 7 E	S2.2 ■ 6 A	S3.1 ■ 5 E	S3.2 ■ 4 A
S4.1 ■ 4 E	S4.2 ■ 3 A												

Les produits de cette série sont également disponibles en coffret. Voir A296.

Produit	Nr.	DC (inch)	DC (inch)	SDL_1 (inch)	OAL (inch)	DCONMS (inch)
A225BS1	BS1	3/64	0.0469	5/64 - 1/16	1.1/2	1/8
A225BS2	BS2	1/16	0.0625	3/32 - 5/64	1.3/4	3/16
A225BS3	BS3	3/32	0.0938	5/32 - 1/8	2"	1/4
A225BS4	BS4	1/8	0.1250	3/16 - 5/32	2.1/4	5/16
A225BS5	BS5	3/16	0.1875	9/32 - 1/4	2.1/2	7/16
A225BS5A	BSSA	7/32	0.2188	5/16 - 9/32	2.3/4	1/2
A225BS6	BS6	1/4	0.2500	3/8 - 5/16	3"	5/8
A225BS7	BS7	5/16	0.3125	15/32 - 13/32	3.1/2	3/4



A237

DORMER



Foret à centrer en HSS-E (5% cobalt), pointe à 118°, chanfrein à 60°, finition brillante

Foret à centrer avec deux extrémités de perçage qui augmentent la productivité par outil. Il a une finition brillante et convient pour percer de nombreux matériaux.

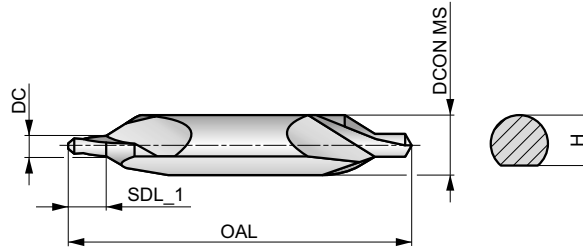

HSS-E	DIN 333A	1xD
60°	Bright	H
R	118°	

Adéquation du groupe de matériaux de la pièce, valeurs de départ pour la vitesse de coupe (m/min) et code Alpha d'avance. Les tableaux d'avances par tour se trouvent à partir de la page 175.

P1.1 ■ 33 I	P1.2 ■ 37 I	P1.3 ■ 38 I	P2.1 ■ 28 I	P2.2 ■ 25 G	P2.3 ■ 22 E	P3.1 ■ 19 F	P3.2 ■ 15 F	P3.3 ■ 13 E	P4.1 ■ 11 F	P4.2 ■ 10 E	P4.3 ■ 8 D	M1.1 ■ 21 E	M1.2 ■ 17 E
M2.1 ■ 18 E	M2.2 ■ 15 E	M3.1 ■ 9 G	M3.2 ■ 8 G	M3.3 ■ 7 G	M4.1 ■ 10 C	K1.1 ■ 30 I	K1.2 ■ 22 F	K1.3 ■ 17 F	K2.1 ■ 25 E	K2.2 ■ 20 E	K2.3 ■ 16 E	K3.1 ■ 22 E	K3.2 ■ 17 E
K3.3 ■ 13 E	K4.1 ■ 20 E	K4.2 ■ 15 E	K4.3 ■ 11 E	K4.4 ■ 10 E	K4.5 ■ 8 E	K5.1 ■ 23 E	K5.2 ■ 17 E	K5.3 ■ 13 E	N1.1 ■ 33 J	N1.2 ■ 25 J	N1.3 ■ 17 I	N2.1 ■ 42 H	N2.2 ■ 37 H
N2.3 ■ 27 H	N3.1 ■ 56 H	N3.2 ■ 33 I	N3.3 ■ 17 G	N4.1 ■ 30 J	N4.2 ■ 28 H	N4.3 ■ 14 F	S1.1 ■ 24 F	S1.2 ■ 13 D	S1.3 ■ 7 B	S2.1 ■ 7 E	S2.2 ■ 6 A	S3.1 ■ 5 E	S3.2 ■ 4 A
S4.1 ■ 4 E	S4.2 ■ 3 A												

Produit	DC	DC	SDL_1	OAL	DCON MS	H
	(mm)	(inch)	(mm)	(mm)	(mm)	(mm)
A2371.6X4.0	1.60	0.0630	2.6 - 2.0	35.0	4.00	3.25 - 3.15
A2372.0X5.0	2.00	0.0787	3.1 - 2.5	40.0	5.00	4.20 - 4.10
A2372.5X6.3	2.50	0.0984	3.8 - 3.1	45.0	6.30	5.35 - 5.25
A2373.15X8.0	3.15	0.1240	4.6 - 3.9	50.0	8.00	6.95 - 6.85
A2374.0X10.0	4.00	0.1575	5.9 - 5.0	55.0	10.00	8.40 - 8.30
A2375.0X12.5	5.00	0.1969	7.2 - 6.3	63.0	12.50	10.95 - 10.85
A2376.3X16.0	6.30	0.2480	8.9 - 8.0	71.0	16.00	14.00 - 13.90
A2378.0X20.0	8.00	0.3150	11.1 - 10.1	80.0	20.00	17.90 - 17.80
A23710.0X25.0	10.00	0.3937	13.8 - 12.8	100.0	25.00	22.50 - 22.40



A238



Foret à centrer en HSS-E (5% Co), pointe à 118°, chnafrein concave, finition brillante

Foret à centrer avec deux extrémités de perçage qui augmentent la productivité par outil. Convient pour percer de nombreux matériaux. Finition brillante et peut être utilisé avec des adaptateurs de chanfreinage spéciaux.

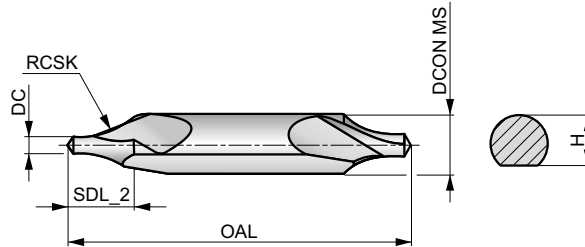

HSS-E	DIN 333R	1xD
R	Bright	H
R	118°	

Adéquation du groupe de matériaux de la pièce, valeurs de départ pour la vitesse de coupe (m/min) et code Alpha d'avance. Les tableaux d'avances par tour se trouvent à partir de la page 175.

P1.1 ■ 33 I	P1.2 ■ 37 I	P1.3 ■ 38 I	P2.1 ■ 28 I	P2.2 ■ 25 G	P2.3 ■ 22 E	P3.1 ■ 19 F	P3.2 ■ 15 F	P3.3 ■ 13 E	P4.1 ■ 11 F	P4.2 ■ 10 E	P4.3 ■ 8 D	M1.1 ■ 21 E	M1.2 ■ 17 E
M2.1 ■ 18 E	M2.2 ■ 15 E	M3.1 ■ 9 G	M3.2 ■ 8 G	M3.3 ■ 7 G	M4.1 ■ 10 C	K1.1 ■ 30 I	K1.2 ■ 22 F	K1.3 ■ 17 F	K2.1 ■ 25 E	K2.2 ■ 20 E	K2.3 ■ 16 E	K3.1 ■ 22 E	K3.2 ■ 17 E
K3.3 ■ 13 E	K4.1 ■ 20 E	K4.2 ■ 15 E	K4.3 ■ 11 E	K4.4 ■ 10 E	K4.5 ■ 8 E	K5.1 ■ 23 E	K5.2 ■ 17 E	K5.3 ■ 13 E	N1.1 ■ 33 J	N1.2 ■ 25 J	N1.3 ■ 17 I	N2.1 ■ 42 H	N2.2 ■ 37 H
N2.3 ■ 27 H	N3.1 ■ 56 H	N3.2 ■ 33 I	N3.3 ■ 17 G	N4.1 ■ 30 J	N4.2 ■ 28 H	N4.3 ■ 14 F	S1.1 ■ 24 F	S1.2 ■ 13 D	S1.3 ■ 7 B	S2.1 ■ 7 E	S2.2 ■ 6 A	S3.1 ■ 5 E	S3.2 ■ 4 A
S4.1 ■ 4 E	S4.2 ■ 3 A												

Produit	DC	DC	SDL_2	OAL	RCSR	DCON MS	H
	(mm)	(inch)	(mm)	(mm)	(mm)	(mm)	(mm)
A2381.6X4.0	1.60	0.0630	4.7 - 4.2	35.0	5.00 - 4.00	4.00	3.25 - 3.15
A2382.0X5.0	2.00	0.0787	5.4 - 5.0	40.0	6.25 - 5.00	5.00	4.20 - 4.10
A2382.5X6.3	2.50	0.0984	6.8 - 6.3	45.0	7.88 - 6.30	6.30	5.35 - 5.25
A2383.15X8.0	3.15	0.1240	8.5 - 8.0	50.0	10.00 - 8.00	8.00	6.95 - 6.85
A2384.0X10.0	4.00	0.1575	10.6 - 10.0	55.0	12.50 - 10.00	10.00	8.40 - 8.30
A2385.0X12.5	5.00	0.1969	13.1 - 12.5	63.0	15.63 - 12.50	12.50	10.95 - 10.85
A2386.3X16.0	6.30	0.2480	16.6 - 16.0	71.0	20.00 - 16.00	16.00	14.00 - 13.90
A2388.0X20.0	8.00	0.3150	20.7 - 20.0	80.0	25.00 - 20.00	20.00	17.90 - 17.80



A242



Foret à centrer long en HSS-E (5% Co), pointe à 118°, chanfrein à 60°, finition brillante

Foret à centrer avec deux extrémités de perçage qui augmentent la productivité par outil. Convient pour percer de nombreux matériaux.

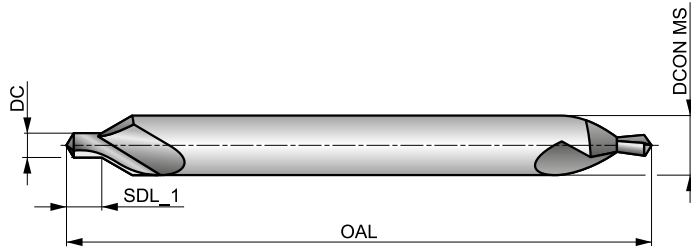

HSS-E		1xD
60°	Bright	
R	118°	

Adéquation du groupe de matériaux de la pièce, valeurs de départ pour la vitesse de coupe (m/min) et code Alpha d'avance. Les tableaux d'avances par tour se trouvent à partir de la page 175.

P1.1 ■ 33 I	P1.2 ■ 37 I	P1.3 ■ 38 I	P2.1 ■ 28 I	P2.2 ■ 25 G	P2.3 ■ 22 E	P3.1 ■ 19 F	P3.2 ■ 15 F	P3.3 ■ 13 E	P4.1 ■ 11 F	P4.2 ■ 10 E	P4.3 ■ 8 D	M1.1 ■ 21 E	M1.2 ■ 17 E
M2.1 ■ 18 E	M2.2 ■ 15 E	M3.1 ■ 9 G	M3.2 ■ 8 G	M3.3 ■ 7 G	M4.1 ■ 10 C	K1.1 ■ 30 I	K1.2 ■ 22 F	K1.3 ■ 17 F	K2.1 ■ 25 E	K2.2 ■ 20 E	K2.3 ■ 16 E	K3.1 ■ 22 E	K3.2 ■ 17 E
K3.3 ■ 13 E	K4.1 ■ 20 E	K4.2 ■ 15 E	K4.3 ■ 11 E	K4.4 ■ 10 E	K4.5 ■ 8 E	K5.1 ■ 23 E	K5.2 ■ 17 E	K5.3 ■ 13 E	N1.1 ■ 33 J	N1.2 ■ 25 J	N1.3 ■ 17 I	N2.1 ■ 42 H	N2.2 ■ 37 H
N2.3 ■ 27 H	N3.1 ■ 56 H	N3.2 ■ 33 I	N3.3 ■ 17 G	N4.1 ■ 30 J	N4.2 ■ 28 H	N4.3 ■ 14 F	S1.1 ■ 24 F	S1.2 ■ 13 D	S1.3 ■ 7 B	S2.1 ■ 7 E	S2.2 ■ 6 A	S3.1 ■ 5 E	S3.2 ■ 4 A
S4.1 ■ 4 E	S4.2 ■ 3 A												

Produit	DC	DC	SDL_1	OAL	DCON MS
	(mm)	(inch)	(mm)	(mm)	(mm)
A2421.0X4.0	1.00	0.0394	1.7 - 1.3	100.0	4.00
A2421.5X5.0	1.50	0.0591	2.6 - 2.0	100.0	5.00
A2422.0X6.0	2.00	0.0787	3.1 - 2.5	100.0	6.00
A2422.5X8.0	2.50	0.0984	3.8 - 3.1	100.0	8.00
A2423.0X8.0	3.00	0.1181	4.6 - 3.9	100.0	8.00
A2423.0X10.0	3.00	0.1181	4.6 - 3.9	100.0	10.00
A2424.0X10.0	4.00	0.1575	5.9 - 5.0	100.0	10.00
A2424.0X12.0	4.00	0.1575	5.9 - 5.0	100.0	12.00
A2425.0X12.0	5.00	0.1969	7.2 - 6.3	100.0	12.00



A088

DORMER



Coffret de forets extra-court A022 en HSS, revêtement TiN en pointe

Coffret robuste contenant 24 diamètres différents de forets extra-courts A022. Les forets conviennent à la fois au perçage sur machines et manuel dans de nombreuses applications. Le revêtement TiN en pointe améliore les performances et prolonge la durée de vie de l'outil.

HSS	DIN ANSI	2.5×D
135°	TiN-Tip	
20-35°	R	DC h8

A=Types dans le coffret, B=Quantité dans le coffret, C=Diamètres dans le coffret.

Produit	Nr.	A	B	C
A0882005	2005	A022	24	1.0 mm - 10.5 mm x 0.5 mm + 3.3 mm, 4.2 mm, 6.8 mm, 10.2 mm

A095

DORMER



Coffret de forets courts A002 en HSS, revêtement TiN en pointe

Coffrets utile en plastique avec différentes tailles métriques, par incréments de 0,5 mm, de nos forets A002. Le coffret regroupe tous les forets ensemble, avec les tailles clairement affichées pour une sélection plus facile. Les forets conviennent à la fois aux machines et aux appareils portatifs. Le revêtement TiN en pointe améliore les performances et prolonge la durée de vie de l'outil.

HSS	DIN 338	4×D
118°	TiN-Tip	
20-35°	R	DC h8

1.0mm =< DC >= 2.9mm avec pointe 4 facettes à 118°. A=Types dans le coffret, B=Quantité dans le coffret, C=Diamètres dans le coffret.

Produit	Nr.	A	B	C
A09518	18	A002	29	1/16 inch - 1/2 inch x 1/64 inch
A09520	20	A002	15	1/16 inch - 1/2 inch x 1/32 inch
A095200	200	A002	24	1.0 mm - 10.5 mm x 0.5 mm + 3.3 mm, 4.2 mm, 6.8 mm, 10.2 mm
A095201	201	A002	19	1.0 mm - 10.0 mm x 0.5 mm
A095202	202	A002	51	1.0 mm - 6.0 mm x 0.1 mm
A095203	203	A002	41	6.0 mm - 10.0 mm x 0.1 mm
A095204	204	A002	25	1.0 mm - 13.0 mm x 0.5 mm
A095206	206	A002	29	1.0 mm - 13.0 mm x 0.5 mm + 3.3 mm, 4.2 mm, 6.8 mm, 10.2 mm
A095209	209	A002	91	1.0 mm - 10.0 mm x 0.1 mm



A087

DORMER



Coffret de forets courts A002 en HSS, revêtement TiN en pointe

Coffret compact facile à transporter contenant 19 diamètres différents de forets populaires A002, avec les tailles clairement affichées pour en faciliter la sélection. Les forets conviennent à la fois au perçage sur machines et manuel ainsi que pour de nombreuses applications. Le revêtement TiN en pointe améliore les performances et prolonge la durée de vie de l'outil.

HSS	DIN 338	4×D
118°	TiN-Tip	
λ20-35°		DC h8

A=Types dans le coffret, B=Quantité dans le coffret, C=Diamètres dans le coffret. 1.0mm =< DC >= 2.9mm avec pointe 4 facettes à 118°.

Produit	Nr.	A	B	C
A087201	201	A002	19	1.0 mm - 10.0 mm x 0.5 mm

A094

DORMER



Coffret de forets courts A002 en HSS, revêtement TiN en pointe

Coffret rotatif contenant des forets A002 de différents diamètres métriques astucieusement conçu pour faciliter la sélection de la taille requise. Faites pivoter le dessus en plastique transparent jusqu'à ce que la taille requise soit mise en évidence par le trou dans le boîtier, et retournez l'ensemble pour retirer le foret.

HSS	DIN 338	4×D
118°	TiN-Tip	
λ20-35°		DC h8

A=Types dans le coffret, B=Quantité dans le coffret, C=Diamètres dans le coffret. 1.0mm =< DC >= 2.9mm avec pointe 4 facettes à 118°.

Produit	Nr.	A	B	C
A094413	413	A002	13	1.5 mm - 6.5 mm x 0.5 mm + 3.3 mm, 4.2 mm
A094419	419	A002	19	1.0 mm - 10.0 mm x 0.5 mm



A089



Coffret de forets courts A002 en HSS, revêtement TiN en pointe

Coffret pratique contenant 5 diamètres différents de forets populaires A002. Les forets conviennent à la fois au perçage sur machines et manuel dans de nombreuses applications. Le revêtement TiN en pointe améliore les performances et prolonge la durée de vie de l'outil.

HSS	DIN 338	4xD
118°	TiN-Tip	
20-35°	R	DC h8

A=Types dans le coffret, B=Quantité dans le coffret, C=Diamètres dans le coffret.

Produit	Nr.	A	B	C
A08910	10	A002	5	A0024.0, A0025.0, A0026.0, A0028.0, A00210.0



A099

DORMER



Présentoir de comptoir avec forets courts A002 en HSS, revêtement TiN en pointe

Présentoir autonome de comptoir contenant une large gamme de tailles de forets A002. Conçu pour être posé sur un comptoir ou toute autre surface plane appropriée pour un affichage bien visible et où les forets peuvent être facilement retirés en cas de besoin. Facile à recharger avec d'autres forets A002, il vous rendra service pendant des années.

HSS	DIN 338	4xD
118°	TiN-Tip	
λ 20-35°	R	DC h8

1.0mm =< DC >= 2.9mm avec pointe 4 facettes à 118°. A=Types dans le coffret, B=Quantité dans le coffret, C=Diamètres dans le coffret.

Produit	Nr.	A	B	C
A099F1	F1	A002	380	5 x (13/32, 7/16, 15/32, 1/2) inch; 10 x (5/64, 7/64, 9/64, 11/64, 13/64, 15/64, 17/64, 9/32, 19/64, 5/16, 21/64, 11/32, 23/64, 3/8) inch; 20 x (1/16, 7/32, 1/4) inch; 30 x 3/32 inch; 40 x (5/32, 3/16) inch; 50 x 1/8 inch
A099M1	M1	A002	340	5 x (10.50, 11.00, 11.50, 12.00, 12.50, 13.00) mm; 10 x (1.50, 2.50, 3.50, 4.50, 5.50, 6.50, 7.00, 7.50, 8.00, 8.50, 9.00, 9.50, 10.00) mm; 20 x (1.00, 5.00, 6.00) mm; 30 x 2.00 mm; 40 x 4.00 mm; 50 x 3.00 mm

A099

DORMER



Présentoir Drillboy avec forets courts A002 en HSS, revêtement TiN en pointe

Présentoir autonome de comptoir contenant une large gamme de tailles de forets A002. Conçu pour être posé sur un comptoir ou toute autre surface plane appropriée pour un affichage bien visible et où les forets peuvent être facilement retirés en cas de besoin. Facile à recharger avec d'autres forets A002, il vous rendra service pendant des années.

HSS	DIN 338	4xD
118°	TiN-Tip	
λ 20-35°	R	DC h8

1.0mm =< DC >= 2.9mm avec pointe 4 facettes à 118°. A=Types dans le coffret, B=Quantité dans le coffret, C=Diamètres dans le coffret.

Produit	Nr.	A	B	C
A099DRILLBOY	DRILLBOY	A002	43	3 x (3.0 mm, 3.3 mm, 3.5 mm, 4.0 mm) + 2 x (4.2 mm, 4.5 mm, 5.0 mm, 5.5 mm, 6.0 mm, 6.5 mm, 6.8 mm, 7.0 mm, 7.5 mm, 8.0 mm) + 8.5 mm, 9.0 mm, 9.5 mm, 10.0 mm, 10.2 mm, 10.5 mm, 11.0 mm, 11.5 mm, 12.0 mm, 12.5 mm, 13.0 mm



A199

DORMER



Présentoir de comptoir avec forets courts A100 en HSS

Présentoir autonome de comptoir contenant une large gamme de tailles de forets A100. Conçu pour être posé sur un comptoir ou toute autre surface plane appropriée pour un affichage bien visible et où les forets peuvent être facilement retirés en cas de besoin. Facile à remplir avec d'autres forets A100, il vous rendra service pendant des années.

HSS	DIN 338	4xD
118°	ST	
20-35°		DC h8

A=Types dans le coffret, B=Quantité dans le coffret, C=Diamètres dans le coffret.

Produit	Nr.	A	B	C
A199F1	F1	A100	380	5 x (13/32, 7/16, 15/32, 1/2) inch; 10 x (5/64, 7/64, 9/64, 11/64, 13/64, 15/64, 17/64, 9/32, 19/64, 5/16, 21/64, 11/32, 23/64, 3/8) inch; 20 x (1/16, 7/32, 1/4) inch; 30 x 3/32 inch; 40 x (5/32, 3/16) inch; 50 x 1/8 inch
A199M1	M1	A100	340	5 x (10.50, 11.00, 11.50, 12.00, 12.50, 13.00) mm; 10 x (1.50, 2.50, 3.50, 4.50, 5.50, 6.50, 7.00, 7.50, 8.00, 8.50, 9.00, 9.50, 10.00) mm; 20 x (1.00, 5.00, 6.00) mm; 30 x 2.00 mm; 40 x 4.00 mm; 50 x 3.00mm

A080

DORMER



Présentoir vide

Présentoir fourni vide afin que les forets puissent être achetés séparément en choisissant les quantités en fonction des ventes au comptoir. Il est en plastique rouge marqué du logo Dormer et d'une image de différents forets Dormer. Les diamètres des forets sont indiqués sur les trois étagères.

Présentoir vide.

Produit	Nr.	C
A080M1EMPTY	M1EMPTY	(1.00, 1.50, 2.00, 2.50, 3.00, 3.50, 4.00, 4.50, 5.00, 5.50, 6.00, 6.50, 7.00, 7.50, 8.00, 8.50, 9.00, 9.50, 10.00, 10.50, 11.00, 11.50, 12.00) mm
A080F1EMPTY	F1EMPTY	(1/16, 5/64, 3/32, 7/64, 1/8, 9/64, 5/32, 11/64, 3/16, 13/64, 7/32, 15/64, 1/4, 17/64, 9/32, 19/64, 5/16, 21/64, 11/32, 3/8, 13/32, 7/16, 1/2) inch



A190

DORMER



Coffret de forets courts A100 en HSS, finition avec traitement vapeur

Coffret pratique en plastique contenant des forets courts A100 avec pointe conventionnelle à 118°. Fourni en jeux de tailles métriques par incréments de 0,1 mm ou 0,5 mm et en pouces rangés pour faciliter la sélection de la taille de foret.

HSS	DIN 338	4xD
118°		
λ 20-35°		DC h8

A=Types dans le coffret, B=Quantité dans le coffret, C=Diamètres dans le coffret. DC ≤ 1mm; 3/64"; N60 Brillant.

Produit	Nr.	A	B	C
A1903	3	A100	21	1/16 inch - 3/8 inch x 1/64 inch
A19012	12	A100	60	No.1 - No.60
A19018	18	A100	29	1/16 inch - 1/2 inch x 1/64 inch
A19020	20	A100	15	1/16 inch - 1/2 inch x 1/32 inch
A190201	201	A100	19	1.0 mm - 10.0 mm x 0.5 mm
A190202	202	A100	51	1.0 mm - 6.0 mm x 0.1 mm
A190203	203	A100	41	6.0 mm - 10.0 mm x 0.1 mm
A190204	204	A100	25	1.0 mm - 13.0 mm x 0.5 mm
A190206	206	A100	29	1.0 mm - 13.0 mm x 0.5 mm + 3.3 mm, 4.2 mm, 6.8 mm, 10.2 mm
A190209 ¹⁾	209	A100	91	1.0 mm - 10.0 mm x 0.1 mm

¹⁾ Vendu en 2 boîtes: boîte 1 contient les tailles (1.0-5.9 x 0.1mm); boîte 2 contient les tailles (6.0-10.0 x 0.1mm).



A191

DORMER



Coffret de forets courts A100 en HSS, finition avec traitement vapeur

Coffret contenant des forets A100 de différents diamètres métriques dans un boîtier compact facile à transporter avec des tailles clairement affichées et une sélection de forets plus facile. Forets courts A100 avec pointe conventionnelle à 118°. Fourni en jeux de tailles métriques ou en pouces dans un boîtier en plastique pratique qui facilite la sélection de la taille de foret.

HSS	DIN 338	4xD
118°	ST	
20-35°		DC h8

A=Types dans le coffret, B=Quantité dans le coffret, C=Diamètres dans le coffret. DC <= 1mm; 3/64"; N60 Brillant.

Produit	Nr.	A	B	C
A19131M	31M	A100	20	0.3 mm - 1.0 mm x 0.05 mm + 0.38 mm, 0.52 mm, 0.58 mm, 0.78 mm, 0.82 mm
A19161-80	61-80	A100	20	No.61 - No. 80

A191

DORMER



Coffret rotatif de forets courts A100 en HSS, finition avec traitement vapeur

Coffret rotatif contenant des forets A100 de différents diamètres métriques astucieusement conçu pour faciliter la sélection de la taille requise. Faites pivoter le dessus en plastique transparent jusqu'à ce que la taille requise soit mise en évidence par le trou dans le boîtier, et retournez l'ensemble pour retirer le foret.

HSS	DIN 338	4xD
118°	ST	
20-35°		DC h8

A=Types dans le coffret, B=Quantité dans le coffret, C=Diamètres dans le coffret. DC <= 1mm; 3/64"; N60 Brillant.

Produit	Nr.	A	B	C
A191413	413	A100	13	1.5 mm - 6.5 mm x 0.5 mm + 3.3 mm, 4.2 mm
A191419	419	A100	19	1.0 mm - 10.0 mm x 0.5 mm



A188

DORMER



Coffret de forets courts A108 en HSS, finition avec traitement vapeur

Coffret utile en plastique avec différentes tailles, par incréments de 0,5 mm, de nos forets A108. Peut être utilisé dans de nombreuses applications sur machine et manuelles.

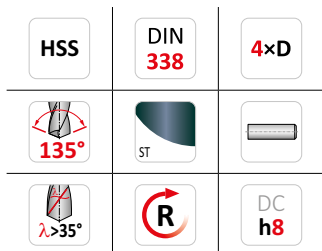

A=Types dans le coffret, B=Quantité dans le coffret, C=Diamètres dans le coffret. DC > 1.5mm; 1/16" avec affûtage en croix.

Produit	Nr.	A	B	C
A188201	201	A108	19	1.0 mm - 10.0 mm x 0.5 mm
A188204	204	A108	25	1.0 mm - 13.0 mm x 0.5 mm

A295

DORMER



Coffret de forets courts A777 en HSS-E (8% cobalt), finition avec traitement bronze

Coffret utile en plastique avec différentes tailles, par incréments de 0,5 mm, de nos forets A777. Il regroupe tous les forets ensemble et dans l'ordre, avec les tailles clairement affichées pour une sélection plus facile. Les forets A777 sont conçus avec une pointe à 135° avec affûtage en croix pour aider à centrer automatiquement le foret et réduire les forces de coupe.

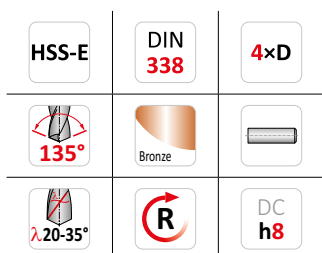

A=Types dans le coffret, B=Quantité dans le coffret, C=Diamètres dans le coffret. DC ≤ 1.4mm avec pointe 4 facettes.

Produit	Nr.	A	B	C
A295219	219	A777	19	1.0 mm - 10.0 mm x 0.5 mm
A295225	225	A777	25	1.0 mm - 13.0 mm x 0.5 mm



A296

DORMER



Coffret de forets à centrer en HSS

Coffret de cinq forets à centrer qui sont livrés dans un boîtier en plastique pratique pour garder tous vos forets ensemble. Les deux extrémités de perçage procurent plus de productivité par outil.

A296200 - 118° de pointe DIN333A, A296225 - 120° de pointe BS328. A=Types dans le coffret, B=Quantité dans le coffret, C=Diamètres dans le coffret.

Produit	Nr.	A	B	C
A296200	200	A200	5	1.00 mm, 2.00 mm, 2.50 mm, 3.15 mm, 4.00 mm
A296225	225	A225	5	BS1, BS2, BS3, BS4, BS5

M150

DORMER



Cône de réduction, trempé

Adaptateur utilisé pour permettre aux forets avec des queues coniques plus petites d'être maintenues dans des broches de machines avec des cônes morse plus grands.

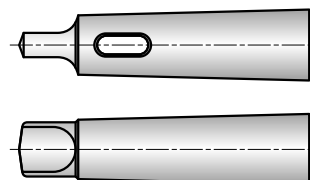

K= cône morse extérieur; K1=cône morse intérieur.

Produit	Nr.	K = Nr.	K1 = Nr.
M1501-0	10	Nr. 1	Nr. 0
M1502-1	21	Nr. 2	Nr. 1
M1503-1	31	Nr. 3	Nr. 1
M1504-1	41	Nr. 4	Nr. 1
M1503-2	32	Nr. 3	Nr. 2
M1504-2	42	Nr. 4	Nr. 2
M1505-2	52	Nr. 5	Nr. 2
M1504-3	43	Nr. 4	Nr. 3
M1505-3	53	Nr. 5	Nr. 3
M1505-4	54	Nr. 5	Nr. 4
M1506-5	65	Nr. 6	Nr. 5



M151

DORMER



Cône de réduction, trempé

Adaptateur utilisé pour permettre aux forets avec des queues coniques plus petites d'être maintenues dans des broches de machines avec des cônes morse plus grands.

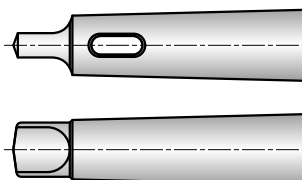

K= cône morse extérieur; K1=cône morse intérieur.

Produit	Nr.	K = Nr.	K1 = Nr.
M1511-0	10	Nr. 1	Nr. 0
M1512-1	21	Nr. 2	Nr. 1
M1513-1	31	Nr. 3	Nr. 1
M1514-1	41	Nr. 4	Nr. 1
M1513-2	32	Nr. 3	Nr. 2
M1514-2	42	Nr. 4	Nr. 2
M1515-2	52	Nr. 5	Nr. 2
M1514-3	43	Nr. 4	Nr. 3
M1515-3	53	Nr. 5	Nr. 3
M1515-4	54	Nr. 5	Nr. 4
M1516-5	65	Nr. 6	Nr. 5

M152

DORMER



Extracteur de foret

Extracteur utilisé pour éjecter les forets à queue conique des broches de machines et des manchons à queue cône morse.



Produit	Nr.
M1520	Nr. 0
M15212	Nr. 1 + 2
M15234	Nr. 3 + 4
M15245	Nr. 4 + 5
M1526	Nr. 6



TABLEAU DES AVANCES POUR LES FORETS MONOBLOCS

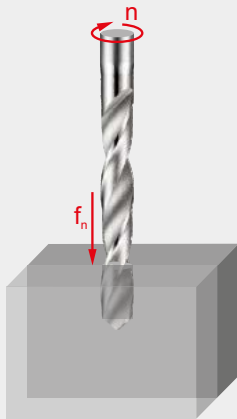

Avance par tour (f_n en mm/tr)
Ajuster ces valeurs de $\pm 25\%$ selon les conditions de travail.

Comment trouver l'avance par tour (f_n) grâce à ce tableau :

1. Rechercher le code Alpha sur la page produit (par ex. 46J, « J » étant le code Alpha).
2. Trouver le diamètre le plus proche de celui recherché pour votre application (première ligne du tableau).
3. Rechercher votre code Alpha dans la colonne gauche du tableau.
4. La cellule à l'intersection de la colonne Diamètre et de la ligne code Alpha indique l'avance par tour (f_n).

		ø DC (mm)																		
		0.15	0.50	1.00	2.00	3.00	4.00	5.00	6.00	8.00	10.00	12.00	15.00	16.00	20.00	25.00	30.00	40.00	50.00	100.00
Avances	A	0.003	0.006	0.012	0.023	0.029	0.032	0.036	0.042	0.054	0.062	0.069	0.082	0.086	0.110	0.125	0.135	0.155	0.175	0.263
	B	0.004	0.007	0.014	0.028	0.037	0.041	0.046	0.053	0.067	0.080	0.090	0.103	0.108	0.135	0.153	0.165	0.188	0.208	0.312
	C	0.004	0.008	0.015	0.032	0.044	0.050	0.056	0.064	0.080	0.098	0.110	0.125	0.130	0.160	0.180	0.195	0.220	0.240	0.360
	D	0.004	0.008	0.016	0.038	0.053	0.060	0.068	0.078	0.098	0.119	0.130	0.149	0.155	0.188	0.210	0.228	0.253	0.275	0.413
	E	0.004	0.009	0.017	0.043	0.062	0.071	0.080	0.092	0.115	0.140	0.150	0.173	0.180	0.215	0.240	0.260	0.285	0.310	0.465
	F	0.005	0.009	0.018	0.050	0.073	0.084	0.095	0.109	0.138	0.165	0.178	0.202	0.210	0.248	0.275	0.295	0.320	0.343	0.515
	G	0.005	0.010	0.019	0.056	0.084	0.096	0.109	0.126	0.160	0.190	0.205	0.231	0.240	0.280	0.310	0.330	0.355	0.375	0.563
	H	0.005	0.010	0.020	0.066	0.102	0.116	0.130	0.150	0.190	0.228	0.243	0.271	0.280	0.320	0.355	0.375	0.398	0.418	0.627
	I	0.005	0.011	0.021	0.076	0.119	0.134	0.150	0.173	0.220	0.265	0.280	0.310	0.320	0.360	0.400	0.420	0.440	0.460	0.690
	J	0.006	0.012	0.024	0.084	0.135	0.152	0.170	0.197	0.250	0.298	0.315	0.349	0.360	0.405	0.445	0.465	0.485	0.503	0.755
	K	0.007	0.013	0.026	0.092	0.150	0.170	0.190	0.220	0.280	0.330	0.350	0.388	0.400	0.450	0.490	0.510	0.530	0.545	0.818
	L	0.007	0.014	0.028	0.101	0.165	0.186	0.208	0.240	0.305	0.360	0.385	0.419	0.430	0.485	0.525	0.545	0.568	0.588	0.882
	M	0.008	0.015	0.030	0.110	0.180	0.202	0.225	0.260	0.330	0.390	0.420	0.450	0.460	0.520	0.560	0.580	0.605	0.630	0.945
	N	0.008	0.016	0.032	0.119	0.195	0.218	0.242	0.280	0.355	0.420	0.455	0.481	0.490	0.555	0.595	0.615	0.642	0.672	1.008
	S	0.002	0.004	0.008	0.014	0.020	0.025	0.030	0.037	0.050	0.080	0.100	0.123	0.130	0.150	0.170	0.190	0.220	0.240	–
	T	0.004	0.008	0.015	0.028	0.040	0.050	0.060	0.070	0.090	0.110	0.130	0.160	0.170	0.190	0.210	0.230	0.260	0.275	–
	U	0.007	0.013	0.026	0.048	0.070	0.080	0.090	0.107	0.140	0.170	0.200	0.223	0.230	0.240	0.270	0.300	0.360	0.375	–
	V	0.010	0.019	0.038	0.069	0.100	0.115	0.130	0.153	0.200	0.250	0.280	0.310	0.320	0.340	0.400	0.440	0.510	0.530	–
	W	0.012	0.025	0.049	0.089	0.130	0.150	0.170	0.200	0.260	0.330	0.380	0.418	0.430	0.450	0.470	0.490	0.520	0.540	–
	X	0.014	0.028	0.056	0.103	0.150	0.180	0.210	0.250	0.330	0.420	0.480	0.533	0.550	0.580	–	–	–	–	–
Y	0.017	0.034	0.068	0.124	0.180	0.220	0.260	0.317	0.430	0.550	0.700	0.700	0.700	0.740	–	–	–	–	–	
Z	0.024	0.047	0.094	0.172	0.250	0.325	0.400	0.533	0.800	1.000	1.100	1.175	1.200	1.200	–	–	–	–	–	



PERÇAGE
INFORMATIONS TECHNIQUES

FORETS MONOBLOCS – INFORMATIONS TECHNIQUES

Nomenclature

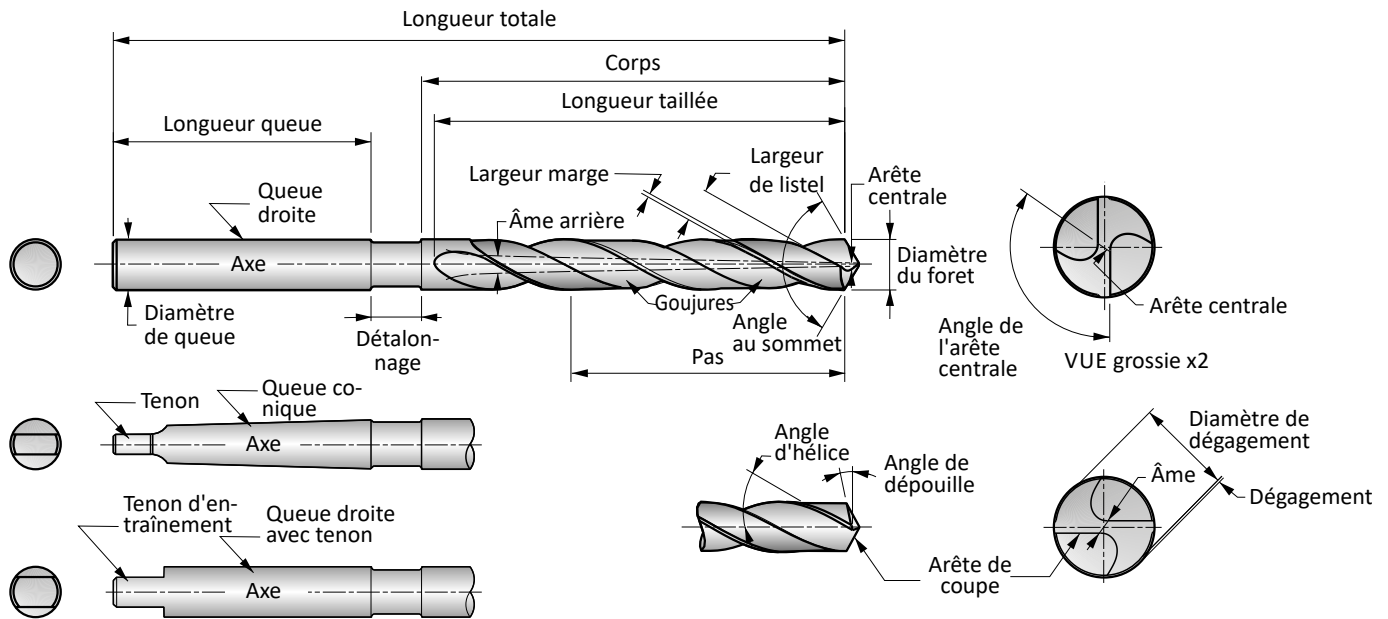

- **Axe** : ligne droite imaginaire qui forme l'axe longitudinal d'un foret.
- **Conicité arrière** : légère réduction de diamètre longitudinal vers la queue d'un foret.
- **Corps** : partie du foret qui s'étend de la queue ou du détailonnage jusqu'à l'extrémité des arêtes de coupe.
- **Dégagement** : partie du listel qui a été réduite pour offrir une dépouille et éviter le contact avec les parois du trou.
- **Arête centrale** : intersection des arêtes de coupe à l'extrémité de l'âme.
- **Angle de l'arête centrale** : angle obtus entre l'arête centrale et l'arête de coupe, vu de l'extrémité du foret.
- **Diamètre de dégagement** : diamètre de dégagement (partie retirée) derrière les listels.
- **Foret** : outil de coupe rotatif ayant une ou plusieurs arêtes de coupe et une ou plusieurs goujures hélicoïdales ou droites pour l'évacuation des copeaux et le passage d'un fluide de coupe.
- **Diamètre du foret** : diamètre d'un foret mesuré à son extrémité.
- **Longueur taillée** : distance entre les angles externes des arêtes de coupe et l'extrémité des goujures côté queue. Cette distance s'étend jusqu'à la naissance des goujures et ne correspond donc pas à la longueur utile de ces dernières.
- **Goujures** : rainures hélicoïdales ou droites taillées dans le corps d'un foret pour former des arêtes de coupe, permettre l'évacuation des copeaux et laisser le fluide de coupe atteindre le tranchant.
- **Angle d'hélice** : angle formé entre la tangente en un point au bord d'attaque du listel et un plan contenant l'axe d'un foret.
- **Listel** : partie périphérique du corps entre les goujures adjacentes.
- **Largeur de listel** : distance entre le bord d'attaque et le talon du listel, mesurée à angle droit par rapport au bord d'attaque.
- **Pas** : avance axiale d'un bord d'attaque du listel en un tour complet de ce dernier.
- **Angle de dépouille** : angle de dépouille axial à l'angle externe de l'arête, mesuré par projection sur un plan tangent à la périphérie à l'angle externe de l'arête.
- **Arêtes** : arêtes de coupe d'un foret à deux goujures s'étendant du bord de l'arête centrale à la périphérie.
- **Marge** : partie cylindrique du listel, qui n'a pas été retirée, pour offrir un dégagement.
- **Détalonnage** : section cylindrique de diamètre réduit entre le corps et la queue d'un foret.
- **Longueur totale** : distance entre l'extrémité de la queue et les angles externes des arêtes de coupe. Cette distance n'inclut pas la queue conique souvent présente sur les forets de ce type, ni l'extrémité de coupe conique présente sur les forets à queue droite comme à queue conique.
- **Pointe** : extrémité coupante d'un foret formée par les extrémités des listels et de l'âme. La pointe semble conique, visuellement, mais elle ne l'est pas vraiment pour offrir un dégagement entre les arêtes de coupe.
- **Pointe conventionnelle** : les pointes conventionnelles présentent un angle de 118° et sont les plus couramment utilisées car elles donnent des résultats satisfaisants dans une grande variété de matériaux. Une limite à cette polyvalence est toutefois l'arête centrale droite qui contribue à une certaine déviation au point de perçage, ce qui rend souvent nécessaire de repérer le trou pour améliorer la précision.

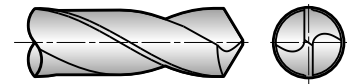

- **Pointe en croix** : les forets à pointe en croix (communément appelées « forets de vilebrequin ») ont été initialement développés pour percer des trous d'huile profonds dans les vilebrequins automobiles. Depuis, cette conception a été largement adoptée pour de nombreux types de forets, à 118° et 135°, y compris les forets à angles au sommet. Ses principaux avantages sont la réduction des contraintes de poussée et l'élimination de toute déviation au point de perçage. Ce dernier avantage est particulièrement intéressant en perçage manuel ou lorsqu'il est impossible d'utiliser

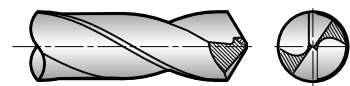

FORETS MONOBLOCS – INFORMATIONS TECHNIQUES

- **Pointe fendue** : les forets à pointe fendue ont été développés pour le perçage d'alliages tenaces. Les forets à âme épaisse incluent souvent une pointe fendue pour que celle-ci résiste aux contraintes de poussée plus élevées, imposées lors du perçage de ce type de matériaux. Comme pour la pointe en croix, la pointe fendue possède deux arêtes de coupe positives s'étendant jusqu'au centre du foret. Ces arêtes de coupe secondaires, qui ne dépassent pas la moitié de l'arête de coupe principale, peuvent aider à contrôler l'évacuation des copeaux et à réduire le couple nécessaire au perçage des matériaux tenaces. Les pointes fendues peuvent être intégrées à des forets de 118° et 135°, faisant d'eux des outils très polyvalents.

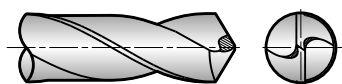

- **Angle au sommet** : angle formé entre les arêtes de coupe projetées sur un plan parallèle à l'axe du foret et aux deux arêtes.
- **Hauteur d'arête relative** : différence de relevé entre les arêtes de coupe d'un foret, mesurée à angle droit par rapport à l'arête et à une distance donnée par rapport à l'axe de l'outil.
- **Queue** : partie du foret utilisée pour la prise et l'entraînement.
- **Tenon** : extrémité plate d'une queue conique destinée à s'insérer dans la fente d'une douille.
- **Tenon d'entraînement** : deux découpes plates d'entraînement parallèles et opposées à l'extrémité d'une queue droite.
- **Queue conique** : les forets à queue conique conviennent au montage direct dans les broches de machines, les manchons d'entraînement ou les douilles. Les queues coniques sont généralement dotées d'un tenon.
- **Âme** : partie centrale du corps d'un foret où se rejoignent les liscs. L'extrémité de l'âme forme l'arête centrale d'un foret à deux goujures.
- **Épaisseur de l'âme** : épaisseur de l'âme mesurée à l'extrémité du foret, sauf mention contraire.

Recommandations générales pour le perçage

1. Sélectionner le foret le mieux adapté à l'application, en tenant compte du matériau à usiner, de la capacité de la machine-outil et du fluide de coupe utilisé.
2. La flexibilité entre la pièce et l'axe de la machine peut abîmer le foret aussi bien que la pièce et la machine. Il faut donc assurer un maximum de stabilité à toutes les étapes. Vous pouvez limiter ce problème en choisissant le foret le plus court possible pour l'application.
3. Le mandrin est un aspect important dans l'opération de perçage et le foret ne peut se permettre de casser ou de bouger du porte-outil.
4. Pour bien utiliser des forets à queue cône Morse, un ajustement précis entre les surfaces coniques de l'outil et le porte-outil est in-

dispensable. Il est recommandé d'utiliser un maillet en caoutchouc pour enfoncer le foret dans le porte-outil.

5. Il est recommandé d'utiliser les fluides et les lubrifiants requis pour l'opération de perçage en question. Lors de l'utilisation de fluides de coupe ou de lubrifiants, il faut assurer un arrosage copieux, et plus particulièrement à la pointe du foret.
6. L'évacuation des copeaux durant le perçage est essentielle pour assurer une bonne opération de perçage. Ne jamais permettre aux copeaux de rester dans la goujure.
7. Lors du réaffûtage d'un foret, toujours veiller à ce que la géométrie de la pointe soit respectée et que toute trace d'usure ait été éliminée.



FORETS MONOBLOCS – INFORMATIONS TECHNIQUES

Stratégie de perçage de trous profonds

Lors du perçage de trous profonds, il est possible d'utiliser différentes méthodes. L'exemple ci-dessous nous montre quatre possibilités de perçage de trous de 10 x le diamètre.

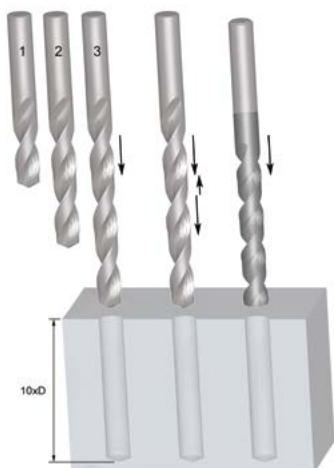

	Perçage en série	Perçage en série
No de forets	3 (2,5×D, 6×D, 10×D)	2 (2,5×D, 10×D)
Type de forets	Géométrie standard, utilisation générale	Géométrie standard, utilisation générale
+ / -	Coûteux Long	Plus rentable Rapide

	Perçage en plusieurs passes	Perçage en une seule passe
No de forets	1 (10×D)	1 (10×D)
Type de forets	Géométrie standard, utilisation générale	Outils d'utilisation spécifique
+ / -	Long	Rentable Rapide

Pression de refroidissement interne

Problème	Cause	Remède
Tenon cassé ou tordu	Mauvais contact entre la queue et le porte-outil	S'assurer du bon état de la queue et du porte-outil
Casse de l'âme	Avance trop élevée	Réduire l'avance à un taux optimum
	Dépouille initiale insuffisante	Réaffûter selon les spécifications correctes
	Amincissement de l'âme excessif	Réaffûter selon les spécifications correctes
	Lourd impact au niveau de la pointe du foret	Eviter tout impact au niveau de la pointe du foret. Faire attention lors de la mise en place ou de l'éjection des forets queue cône morse de l'axe
Usure des angles extérieurs	Vitesse excessive	Réduire la vitesse – peut-être augmenter l'avance
Casse des angles extérieurs	Pièce à usiner instable	Réduire le jeu de la pièce
Eclat des lèvres de coupe	Dépouille initiale excessive	Réaffûter selon les spécifications correctes
Casse de la goujure	Choc sur les goujures	Adopter un concept de perçage en plusieurs passes/en série
	Glisse du foret	S'assurer que le foret est bien maintenu dans le mandrin et dans l'axe
Finition en spirale dans le trou	Avance insuffisante	Augmenter la vitesse de coupe
	Manque de précision dans le positionnement	Utiliser un foret de pré-perçage avant le perçage
Trou trop grand	Géométrie de pointe incorrecte	Vérifier la géométrie de pointe
	Mauvaise évacuation des copeaux	Ajuster la vitesse, l'avance et la longueur des passes pour obtenir une meilleure fragmentation des copeaux



FORETS MONOBLOCS – INFORMATIONS TECHNIQUES

Dimension de trou et tolérances acceptables

Plus les configurations géométrie / substrat / revêtement sont méthodiques, plus la capacité d'un foret à produire un trou précis augmente. En général, un outil à géométrie standard produira un trou

d'une tolérance H12. Cependant, lorsque la configuration du foret devient plus méthodique, la dimension du trou fini, dans des conditions favorables, peut se rapprocher de la tolérance H8.

Pour offrir une vue d'ensemble exhaustive, voici une liste des types de produits et des tolérances de trous correspondantes :

Forets acier rapide (HSS) d'utilisation générale – H12

Forets à rainure parabolique acier rapide (HSS) / HSCo pour trous profonds (PFX) – H10

Forets acier rapide (HSS) / HSCo à revêtement TiN / TiALN hautes performances (ADX) – H10

Forets monoblocs en carbure à revêtement TiN / TiALN hautes performances (CDX, Force) – H8/H9

Diamètre de trou nominal (mm)

Ø (mm)	H8	H9	H10	H12
≤ 3	0 / +0.014	0 / +0.025	0 / +0.040	0 / +0.100
> 3 ≤ 6	0 / +0.018	0 / +0.030	0 / +0.048	0 / +0.120
> 6 ≤ 10	0 / +0.022	0 / +0.036	0 / +0.058	0 / +0.150
> 10 ≤ 18	0 / +0.027	0 / +0.043	0 / +0.070	0 / +0.180
> 18 ≤ 30	0 / +0.033	0 / +0.052	0 / +0.084	0 / +0.210

Diamètre de trou nominal (pouces)

Ø (po)	H8	H9	H10	H12
≤ .1181	0 / +0.0006"	0 / +0.0010"	0 / +0.0016"	0 / +0.0040"
>.1181≤.2362	0 / +0.0007"	0 / +0.0012"	0 / +0.0019"	0 / +0.0048"
>.2362≤.3937	0 / +0.0009"	0 / +0.0015"	0 / +0.0023"	0 / +0.0059"
>.3937≤.7087	0 / +0.0011"	0 / +0.0017"	0 / +0.0028"	0 / +0.0071"
>.7087≤1.1811	0 / +0.0013"	0 / +0.0021"	0 / +0.0033"	0 / +0.0083"

Compte tenu de la capacité de certains forets à produire des trous avec une tolérance très serrée, il convient d'accorder une attention particulière aux trous devant faire l'objet d'opérations secondaires

(taraudage, alésage, etc.). Le diamètre du foret devra être supérieur à la recommandation pour tenir compte du fait que la taille du trou produit sera plus petite.

Optimisation des opérations de perçage et résolution de problèmes

Choix du foret

Utiliser le foret le plus court possible pour l'application afin d'obtenir une rigidité maximale de l'outil.

Porte-outils

Les porte-outils et pinces de serrage doivent assurer une bonne concentricité entre le foret et la broche de la machine. Utiliser une butée positive pour empêcher l'outil de reculer dans le porte-outil. Ne jamais serrer l'outil par les goujures ni serrer exagérément le porte-outil. La sortie en longueur de l'outil dans le porte-outil doit être vérifiée et maintenue avec précision.

Pièce usinée

La pièce à usiner doit être stable et correctement fixée pour limiter

toute déviation, en particulier pour les trous débouchants.

Fluides de coupe

L'utilisation d'un fluide de coupe est recommandée pour le perçage des aciers doux et des alliages haute température. Le fluide de coupe a pour objectif d'évacuer les copeaux loin de l'outil et de la pièce usinée. Une pression ou un volume excessifs de fluide de coupe pourrait avoir un impact négatif sur les performances. Dans les forets à canaux de refroidissement, la pression du fluide de coupe requise est supérieure à celle normalement exigée : elle doit être d'au moins 10,3 bar ou 150 PSI. Plus le diamètre du foret est petit, plus la pression augmente, ce qui permet d'évacuer plus efficacement les copeaux dans des zones étroites.



FORETS MONOBLOCS – INFORMATIONS TECHNIQUES

Guide de résolution de problèmes

Problème	Solution
Usure des angles externes	Réduire la vitesse de coupe.
	Augmenter l'avance (IPR).
	Améliorer l'orientation du flux du fluide de coupe.
	Augmenter la pression du fluide de coupe.
	Ajouter une arête.
Écaillage de l'arête centrale	Vérifier la précision de sortie du foret.
	Vérifier le serrage de la pièce usinée et le mouvement.
	Vérifier le centrage de la pointe et la hauteur d'arête.
	Augmenter l'avance.
Écaillage des arêtes de coupe	Vérifier la précision de sortie du foret.
	Vérifier le serrage de la pièce usinée et le mouvement.
	Réduire la vitesse.
	Réduire le jeu de la pointe.
	Réaffûter.
Listels ébréchés	Vérifier que la pièce usinée ne bouge pas.
	Augmenter la conicité arrière.
	Vérifier la précision de sortie du foret.
	Bourrage de copeaux ; augmenter l'angle d'hélice des goujures ou le nombre de passes (HSS ou HSCO uniquement).
	Ralentir l'hélice, perçage horizontal.
	Augmenter la vitesse de coupe.
	En préperçage, réduire l'avance.
	Améliorer l'orientation du flux du fluide de coupe.
Augmenter la pression du fluide de coupe.	
Trou surdimensionné	Augmenter la vitesse, réduire l'avance.
	Vérifier le serrage de la pièce usinée et le mouvement.
	Vérifier la précision de sortie du foret.
	Bourrage de copeaux ; augmenter l'angle d'hélice des goujures ou le nombre de passes (HSS ou HSCO uniquement).
	Vérifier le centrage de la pointe et la hauteur d'arête.
Trou sous dimensionné	Améliorer l'orientation du flux du fluide de coupe.
	Réduire la vitesse de coupe, augmenter l'avance.
	Vérifier le diamètre du foret.
Trou non rond	Vérifier la précision de sortie du foret.
	Vérifier le serrage de la pièce usinée et le mouvement.
	Vérifier le centrage de la pointe et la hauteur d'arête.
	Bourrage de copeaux ; augmenter l'angle d'hélice des goujures ou le nombre de passes (HSS ou HSCO uniquement).
Rupture du foret	Bourrage de copeaux ; augmenter l'angle d'hélice des goujures ou le nombre de passes (HSS ou HSCO uniquement).
	Vérifier le serrage de la pièce usinée et le mouvement.
	Vérifier la précision de sortie du foret.
	Réduire la vitesse de coupe, augmenter l'avance.
	Améliorer l'orientation du flux du fluide de coupe.
	Augmenter la pression du fluide de coupe.



INFORMATIONS TECHNIQUES GÉNÉRALES

	Nuance	Dureté (HV10)	C %	W %	Mo %	Cr %	V %	Co %	Matériau de l'outil
	M2	810 – 850	0.9	6.4	5.0	4.2	1.8	–	HSS
	M35	830 – 870	0.93	6.4	5.0	4.2	1.8	4.8	HSCO
	M42	870 – 960	1.08	1.5	9.4	3.9	1.2	8.0	

Propriétés	Aciers rapides (HSS)	Carbures	K10/30F (pour outils monoblocs généralement)
Dureté (HV30)	800-950	1300 – 1800	1600
Densité (g/cm ³)	8.0 – 9.0	7.2 – 15	14.45
Résistance à la compression (N/mm ²)	3000 – 4000	3000 – 8000	6250
Résistance à la flexion (N/mm ²)	2500 – 4000	1000 – 4700	4300
Résistance thermique (°C)	550	1000	900
Module de cisaillement (KN/mm ²)	260 – 300	460 – 630	580
Taille de grain (µm)	–	0.2 – 10	0.8

La combinaison de particules dures (WC) et d'un métal liant (Co) fait évoluer les caractéristiques comme suit :

Caractéristique	Teneur supérieure en WC	Teneur supérieure en Co
Dureté	Dureté supérieure	Dureté inférieure
Résistance à la compression (CS)	CS supérieure	CS inférieure
Résistance à la flexion (BS)	BS inférieure	BS supérieure

La taille de grain a également une influence sur les propriétés du matériau. Plus la taille est réduite, plus la dureté augmente ; la ténacité augmente avec la taille du grain.

Exemples de propriétés de revêtement et traitement de surface

Traitements de surface	Couleur	Matériau de revêtement	Dureté (HV)	Épaisseur (µm)	Structure du revêtement	Coef. frott. contre acier	Temp. max. appli. (°C)
	Gris foncé	Fe 304	400	Max. 5	Conversion en surface	–	550
	Bronze	Fe 304	400	Max. 5	Conversion en surface	–	550
	Doré	TiN	2300	1-4	Monocouche	0.4	600
	Gris noir	TiAlN	3300	3	Nanostructure	0.3-0.35	900



INFORMATIONS TECHNIQUES GÉNÉRALES

Tolérances standard pour les arbres et trous

Valeurs de tolérance exprimées en microns (μm)

Formule ...1 μm = 0,001 mm / 0,000039" pouce

Tolérance	Diamètre (mm)							
	> 1 ≤ 3	> 3 ≤ 6	> 6 ≤ 10	> 10 ≤ 18	> 18 ≤ 30	> 30 ≤ 50	> 50 ≤ 80	> 80 ≤ 120
	Diamètre (pouces)							
	> 0.039" ≤ 0.118"	> 0.118" ≤ 0.236"	> 0.236" ≤ 0.394"	> 0.394" ≤ 0.709"	> 0.709" ≤ 1.181"	> 1.181" ≤ 1.968"	> 1.968" ≤ 3.149"	> 3.149" ≤ 4.724"
Valeurs de tolérance (μm)								
e8	-14 / -28	-20 / -38	-25 / -47	-32 / -59	-40 / -73	-50 / -89	-60 / -106	-72 / -126
f6	-6 / -12	-10 / -18	-13 / -22	-16 / -27	-20 / -33	-25 / -41	-30 / -49	-36 / -58
f7	-6 / -16	-10 / -22	-13 / -28	-16 / -34	-20 / -41	-25 / -50	-30 / -60	-36 / -71
h6	0 / -6	0 / -8	0 / -9	0 / -11	0 / -13	0 / -16	0 / -19	0 / -22
h7	0 / -10	0 / -12	0 / -15	0 / -18	0 / -21	0 / -25	0 / -30	0 / -35
h8	0 / -14	0 / -18	0 / -22	0 / -27	0 / -33	0 / -39	0 / -46	0 / -54
h9	0 / -25	0 / -30	0 / -36	0 / -43	0 / -52	0 / -62	0 / -74	0 / -87
h10	0 / -40	0 / -48	0 / -58	0 / -70	0 / -84	0 / -100	0 / -120	0 / -140
h11	0 / -60	0 / -75	0 / -90	0 / -110	0 / -130	0 / -160	0 / -190	0 / -220
h12	0 / -100	0 / -120	0 / -150	0 / -180	0 / -210	0 / -250	0 / -300	0 / -350
k10	+40 / 0	+48 / 0	+58 / 0	+70 / 0	+84 / 0	+100 / 0	+120 / 0	+140 / 0
k12	+100 / 0	+120 / 0	+150 / 0	+180 / 0	+210 / 0	+250 / 0	+300 / 0	+350 / 0
m7	+2 / +12	+4 / +16	+6 / +21	+7 / +25	+8 / +29	+9 / +34	+11 / +41	+13 / +48
js14	+/- 125	+/- 150	+/- 180	+/- 215	+/- 260	+/- 310	+/- 370	+/- 435
js16	+/- 300	+/- 375	+/- 450	+/- 550	+/- 650	+/- 800	+/- 950	+/- 1100
H7	+10 / 0	+12 / 0	+15 / 0	+18 / 0	+21 / 0	+25 / 0	+30 / 0	+35 / 0
H8	+14 / 0	+18 / 0	+22 / 0	+27 / 0	+33 / 0	+39 / 0	+46 / 0	+54 / 0
H9	+25 / 0	+30 / 0	+36 / 0	+43 / 0	+52 / 0	+62 / 0	+74 / 0	+87 / 0
H12	+100 / 0	+120 / 0	+150 / 0	+180 / 0	+210 / 0	+250 / 0	+300 / 0	+350 / 0
P9	-6 / -31	-12 / -42	-15 / -51	-18 / -61	-22 / -74	-26 / -86	-32 / -106	-37 / -124
S7	-13 / -22	-15 / -27	-17 / -32	-21 / -39	-27 / -48	-34 / -59	-42 / -72	-58 / -93



INFORMATIONS TECHNIQUES GÉNÉRALES

Tableau des vitesses de coupe

		Vc															
m/min.		5	8	10	15	20	25	30	40	50	60	70	80	90	100	110	150
SFM (pieds/min.)		16	26	32	50	66	82	98	130	165	197	230	262	296	330	362	495
Ø		Tr/min															
mm	po																
1.00	—	1592	2546	3183	4775	6366	7958	9549	12732	15916	19099	22282	25465	28648	31831	35014	47747
1.50	—	1061	1698	2122	3183	4244	5305	6366	8488	10610	12732	14854	16977	19099	21221	23343	31831
2.00	—	796	1273	1592	2387	3183	3979	4775	6366	7958	9549	11141	12732	14324	15916	17507	23873
2.50	—	637	1019	1273	1910	2546	3183	3820	5093	6366	7639	8913	10186	11459	12732	14006	19099
3.00	—	531	849	1061	1592	2122	2653	3183	4244	5305	6366	7427	8488	9549	10610	11671	15916
3.18	1/8	500	801	1001	1501	2002	2502	3003	4004	5005	6006	7007	8008	9009	10010	11011	15015
3.50	—	455	728	909	1364	1819	2274	2728	3638	4547	5457	6366	7276	8185	9095	10004	13642
4.00	—	398	637	796	1194	1592	1989	2387	3183	3979	4775	5570	6366	7162	7958	8754	11937
4.50	—	354	566	707	1061	1415	1768	2122	2829	3537	4244	4951	5659	6366	7074	7781	10610
4.76	3/16	334	535	669	1003	1337	1672	2006	2675	3344	4012	4681	5350	6018	6687	7356	10031
5.00	—	318	509	637	955	1273	1592	1910	2546	3183	3820	4456	5093	5730	6366	7003	9549
6.00	—	265	424	531	796	1061	1326	1592	2122	2653	3183	3714	4244	4775	5305	5836	7958
6.35	1/4	251	401	501	752	1003	1253	1504	2005	2506	3008	3509	4010	4511	5013	5514	7519
7.00	—	227	364	455	682	909	1137	1364	1819	2274	2728	3183	3638	4093	4547	5002	6821
7.94	5/16	200	321	401	601	802	1002	1203	1604	2004	2405	2806	3207	3608	4009	4410	6013
8.00	—	199	318	398	597	796	995	1194	1592	1989	2387	2785	3183	3581	3979	4377	5968
9.00	—	177	283	354	531	707	884	1061	1415	1768	2122	2476	2829	3183	3537	3890	5305
9.53	3/8	167	267	334	501	668	835	1002	1336	1670	2004	2338	2672	3006	3340	3674	5010
10.00	—	159	255	318	477	637	796	955	1273	1592	1910	2228	2546	2865	3183	3501	4775
11.11	7/16	143	229	287	430	573	716	860	1146	1433	1719	2006	2292	2579	2865	3152	4298
12.00	—	133	212	265	398	531	663	796	1061	1326	1592	1857	2122	2387	2653	2918	3979
12.70	1/2	125	201	251	376	501	627	752	1003	1253	1504	1754	2005	2256	2506	2757	3760
14.00	—	114	182	227	341	455	568	682	909	1137	1364	1592	1819	2046	2274	2501	3410
14.29	9/16	111	178	223	334	446	557	668	891	1114	1337	1559	1782	2005	2228	2450	3341
15.00	—	106	170	212	318	424	531	637	849	1061	1273	1485	1698	1910	2122	2334	3183
15.88	5/8	100	160	200	301	401	501	601	802	1002	1203	1403	1604	1804	2004	2205	3007
16.00	—	99	159	199	298	398	497	597	796	995	1194	1393	1592	1790	1989	2188	2984
17.46	11/16	91	146	182	273	365	456	547	729	912	1094	1276	1458	1641	1823	2005	2735
18.00	—	88	141	177	265	354	442	531	707	884	1061	1238	1415	1592	1768	1945	2653
19.05	3/4	84	134	167	251	334	418	501	668	835	1003	1170	1337	1504	1671	1838	2506
20.00	—	80	127	159	239	318	398	477	637	796	955	1114	1273	1432	1592	1751	2387
24.00	—	66	106	133	199	265	332	398	531	663	796	928	1061	1194	1326	1459	1989
25.00	—	64	102	127	191	255	318	382	509	637	764	891	1019	1146	1273	1401	1910
27.00	—	59	94	118	177	236	295	354	472	589	707	825	943	1061	1179	1297	1768
30.00	—	53	85	106	159	212	265	318	424	531	637	743	849	955	1061	1167	1592
32.00	—	50	80	99	149	199	249	298	398	497	597	696	796	895	995	1094	1492
36.00	—	44	71	88	133	177	221	265	354	442	531	619	707	796	884	973	1326
40.00	—	40	64	80	119	159	199	239	318	398	477	557	637	716	796	875	1194
50.00	—	32	51	64	95	127	159	191	255	318	382	446	509	573	637	700	955



INFORMATIONS TECHNIQUES GÉNÉRALES

Dureté et résistance à la traction

HV	HRC	HB	Résistance	
			N/mm ²	Tonnes/po ²
Vickers	Rockwell	Brinell		
940	68	–	–	–
900	67	–	–	–
864	66	–	–	–
829	65	–	–	–
800	64	–	–	–
773	63	–	–	–
745	62	–	–	–
720	61	–	–	–
698	60	–	–	–
675	59	–	–	–
655	58	–	2200	142
650	–	618	2180	141
640	–	608	2145	139
639	57	607	2140	138
630	–	599	2105	136
620	–	589	2070	134
615	56	584	2050	133
610	–	580	2030	131
600	–	570	1995	129
596	55	567	1980	128
590	–	561	1955	126
580	–	551	1920	124
578	54	549	1910	124
570	–	542	1880	122
560	53	532	1845	119
550	–	523	1810	117
544	52	517	1790	116
540	–	513	1775	115
530	–	504	1740	113
527	51	501	1730	112
520	–	494	1700	110
514	50	488	1680	109
510	–	485	1665	108
500	–	475	1630	105
497	49	472	1620	105
490	–	466	1595	103
484	48	460	1570	102
480	–	456	1555	101
473	47	449	1530	99
470	–	447	1520	98
460	–	437	1485	96
458	46	435	1480	96
450	–	428	1455	94
446	45	424	1440	93
440	–	418	1420	92

HV	HRC	HB	Résistance	
			N/mm ²	Tonnes/po ²
Vickers	Rockwell	Brinell		
434	44	413	1400	91
423	43	402	1360	88
413	42	393	1330	86
403	41	383	1300	84
392	40	372	1260	82
382	39	363	1230	80
373	38	354	1200	78
364	37	346	1170	76
355	36	337	1140	74
350	–	333	1125	73
345	35	328	1110	72
340	–	323	1095	71
336	34	319	1080	70
330	–	314	1060	69
327	33	311	1050	68
320	–	304	1030	67
317	32	301	1020	66
310	31	295	995	64
302	30	287	970	63
300	–	285	965	62
295	–	280	950	61
293	29	278	940	61
290	–	276	930	60
287	28	273	920	60
285	–	271	915	59
280	27	266	900	58
275	–	261	880	57
272	26	258	870	56
270	–	257	865	56
268	25	255	860	56
265	–	252	850	55
260	24	247	835	54
255	23	242	820	53
250	22	238	800	52
245	–	233	785	51
243	21	231	780	50
240	–	228	770	50
235	–	223	755	49
230	–	219	740	48
225	–	214	720	47
220	–	209	705	46
215	–	204	690	45
210	–	199	675	44
205	–	195	660	43
200	–	190	640	41



FLUIDES DE COUPE



M200-1



M200 no. 1 Bleue, Huile de coupe pour usinage en conditions difficiles

Une huile de coupe haute performance pour les opérations difficiles, telles que le taraudage, le brochage et le perçage à la main ou avec une perceuse à colonne. Pour augmenter la durée de vie des outils et améliorer les états de surface. Recommandation de premier choix pour l'acier à haute résistance, l'acier inoxydable et les superalliages

Produit	Nr.
M2000.25NR.1BLUE	1/4 Ltr. 12x
M2001.0NR.1BLUE	1 Ltr.
M2005.0NR.1BLUE	5 Ltr.
M20020.0NR.1BLUE	20 Ltr.

M200-2



M200 no. 2 Rouge, Huile de coupe pour Métaux non-ferreux

Une huile pure pour les opérations d'usinage nécessitant l'enlèvement de copeaux dans l'aluminium et ses alliages. Pour la lubrification et le refroidissement afin de favoriser une longue durée de vie des outils et d'assurer un excellent état de surface. Faible impact sur l'environnement grâce à d'excellentes propriétés antibuée, une grande stabilité à l'oxydation et de faibles odeurs.

Produit	Nr.
M2000.25NR.2RED	1/4 Ltr. 12x
M2001.0NR.2RED	1 Ltr.
M2005.0NR.2RED	5 Ltr.



M200-3



M200 no. 3 Verte, Huile de coupe pour applications générales

Une huile de coupe haute performance avec des additifs extrême pression (EP) pour une plus longue durée de vie des outils. Pour les opérations générales de coupe ou de formage, telles que le taraudage, le brochage et le perçage dans l'acier ou l'acier moulé et l'acier inoxydable.

Produit	Nr.
M2000.25NR.3GREEN	1/4 Ltr. 12x
M2001.0NR.3GREEN	1 Ltr.
M2005.0NR.3GREEN	5 Ltr.



DORMER PRAMET



DES NOUVEAUTÉS À PROFUSION

Nous avons ajouté des centaines de nouveaux produits à notre assortiment global d'outils de coupe, avec une attention particulière pour les applications du secteur de l'aéronautique. Toutes ces nouveautés sont désormais réunies en une seule publication disponible au téléchargement. **Simply Reliable.**





ALÉSOIRS ET FRAISES À CHANFREINER





PERÇAGE ET ALÉSAGE – CONTENU GÉNÉRAL

6		WMG ET ISO 13399
12	FORETS MONOBLOCS	INSTRUCTIONS
15		FORETS CARBURE
66		FORETS HSS
176		INFORMATIONS TECHNIQUES
186		FLUIDES DE COUPE
190		ALÉSOIRS ET FRAISES À CHANFREINER
264	FORETS INDEXABLES	INSTRUCTIONS
271		FORETS HYDRA À TÊTE INTERCHANGEABLE
297		INFORMATIONS TECHNIQUES
307		FORETS À PLAQUETTES INDEXABLES
327		INFORMATIONS TECHNIQUES
350	SYSTÈMES D'ALÉSAGE	INSTRUCTIONS
359		TÊTES À ALÉSER
376		ACCESSOIRES D'ALÉSAGE
381		PLAQUETTES
404		ATTACHEMENTS
418		KITS D'ALÉSAGE
429		INFORMATIONS TECHNIQUES



ALÉSOIRS ET FRAISES À CHANFREINER – PAGE DE PRÉSENTATION

1

B400



3

Alésoir machine en carbure à queue cylindrique, précision H7, finition brillante

Alésoir conçu pour fournir une finition dans les limites de la tolérance des trous H7. Offre des performances supérieures et une durée de vie prolongée de l'outil lors de l'alésage de matériaux durs et abrasifs. La conception des goujures en spirale espacées inégalement réduit les vibrations et améliore la cylindricité, la taille et la finition de surface des trous.

2

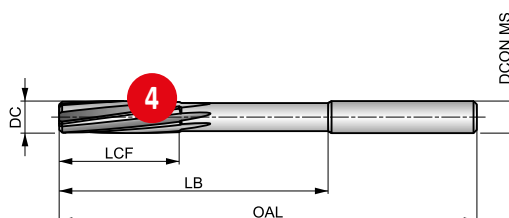

HM	Bright	DIN 8093
R	B	
H7		

5

Adéquation du groupe de matériaux de la pièce, valeurs de départ pour la vitesse de coupe (m/min) et code Alpha d'avance. Les tableaux d'avances par tour se trouvent à partir de la page XY.

P1.1	P1.2	P1.3	P2.1	P2.2	P2.3	P3.1	P3.2	P3.3	P4.1	P4.2	P4.3	M1.1	M1.2
■ 23 B	■ 26 B	■ 27 B	■ 20 B	■ 18 B	■ 16 C	■ 16 B	■ 13 B	■ 11 C	■ 10 B	■ 8 C	■ 7 C	■ 10 C	■ 8 C
M2.1	M2.2	M2.3	K1.1	K1.2	K1.3	K2.1	K2.2	K2.3	K3.1	K3.2	K3.3	K5.1	K5.2
■ 9 C	■ 7 C	■ 6 B	■ 20 D	■ 15 D	■ 11 D	■ 2	■ 17 D	■ 14 D	■ 18 D	■ 14 D	■ 11 D	■ 19 D	■ 15 D
K5.3	N1.1	N1.2	N1.3	N2.1	N2.2	N2.3	N3.1	N3.2	N3.3	N4.1	N4.2		
■ 11 D	■ 60 D	■ 45 D	■ 30 D	■ 38 D	■ 35 D	■ 25 D	■ 64 E	■ 38 E	■ 19 E	■ 35 C	■ 30 C		

6

DCON MS tolerance h6; DC >= 14 mm pointe carbure.

Product	DC	OAL	LCF	LB	NOF	DCON MS
	[mm]	[mm]	[mm]	[mm]		[mm]
B4001.0	1.00	34.0	5.5	15.00	3	1.00
B4001.2	1.20	38.0	7.5	16.50	3	1.20
B4001.4	1.40	40.0	8.0	18.00	3	1.50
B4001.5	1.50	40.0	8.0	18.00	3	1.50
B4001.6	1.60	43.0	9.0	20.00	3	1.60
B4001.8	1.80	46.0	10.0	22.00	4	1.80
B4002.0	2.00	49.0	11.0	24.00	4	2.00
B4002.2	2.20	53.0	12.0	25.00	4	2.20
B4002.5	2.50	57.0	14.0	27.00	4	2.50
B4003.0	2.80	61.0	15.0	30.00	6	3.00
B4003.0	3.00	61.0	15.0	33.00	6	3.00
B4003.2	3.20	65.0	16.0	37.00	6	3.20

7

8

Product	DC	OAL	LCF	LB	NOF	DCON MS
	[mm]	[mm]	[mm]	[mm]		[mm]
B4004.5	4.50	80.0	21.0	52.00	6	4.50
B4005.0	5.00	86.0	23.0	58.00	6	5.00
B4005.5	5.50	93.0	26.0	57.00	6	5.60
B4006.0	6.00	93.0	26.0	57.00	6	5.60
B4006.5	6.50	101.0	28.0	65.00	6	6.30
B4007.0	7.00	109.0	31.0	73.00	6	7.10
B4008.0	8.00	117.0	33.0	81.00	6	8.00
B4009.0	9.00	125.0	36.0	85.00	6	9.00
B40010.0	10.00	133.0	38.0	93.00	6	10.00
B40012.0	12.00	151.0	44.0	111.00	6	10.00
B40014.0	14.00	160.0	47.0	115.00	6	12.50
B40016.0	16.00	170.0	52.0	125.00	6	12.50

Élém.	Description
1	Désignation de l'alésoir
2	Descriptif du produit
3	Illustration
4	Schéma de l'outil

Élém.	Description
5	Caractéristiques du produit
6	Recommandations en fonction du groupe de matériaux, notamment indication de la vitesse et de l'avance
7	Code produit
8	Dimensions du produit



ALÉSOIRS ET FRAISES À CHANFREINER – PRÉSENTATION DES ICÔNES

ICÔNES GÉNÉRALES

	Utilisation principale
	Utilisation possible

TOLÉRANCE DE TROU RÉALISABLE (TCHA)

	h7 – Tolérance de trou norme usine (selon diamètre)		k11 – Tolérance de perçage norme usine (selon diamètre)
	Tolérance de trou haute précision (selon diamètre)		

ANGLE DE TRAVAIL

	Cône 100°		Foret conique 20°		Cône 82°
	Alésage 180°		Cône 60°		Cône 90°

NORME (BSG)

	ANSI – Norme taraud		DIN 219 – Alésoirs creux		DIN 8050 – Alésoirs machine queue droite
	BS 328 – Normes pour forets et alésoirs		DIN 311 – Alésoirs de chaudronnerie à queue cône Morse		DIN 8051 – Alésoirs machine queue cône Morse
	DIN 206 – Alésoirs à main		DIN 334 C – Fraises à ébavurer et à chanfreiner à queue droite		DIN 8093 – Alésoirs machine queue droite
	DIN 208 – Alésoirs machine à queue cône Morse		DIN 334 D – Fraises à ébavurer et à chanfreiner à queue cône Morse		DIN 8094 – Alésoirs machine queue cône Morse
	DIN 212 – Alésoirs machine		DIN 335 A – Fraises à ébavurer et à chanfreiner à queue droite		DIN 9 – Alésoirs machine pour goupille conique
	DIN 217 – Porte-alésoirs creux		DIN 335 C – Fraises à ébavurer et à chanfreiner à queue droite		Normes Dormer
	DIN 2179 – Alésoirs machine pour goupille conique queue cylindrique		DIN 335 D – Fraises à ébavurer et à chanfreiner à queue cône Morse		
	DIN 2180 – Alésoirs machine pour goupille conique queue cône Morse		DIN 373 – Fraises à lamer avec avant-trou		

REVÊTEMENT

	Carbonituration de titane aluminium		Combinaison brillant et traitement vapeur (oxyde)		Nitride de titane aluminium
	Brillant (non revêtu)		Oxyde de bronze et traitement vapeur		Nitride de titane

SENS DE COUPE

	Rotation / coupe à droite
--	---------------------------

CODE MATÉRIAU (BMC)

	Substrat dur (carbure monobloc)		Substrat acier rapide
	Substrat acier rapide à teneur en cobalt		



ALÉSOIRS ET FRAISES À CHANFREINER – PRÉSENTATION DES ICÔNES

FORME ALÉSOIR

A	DIN Forme A – Goujure droite $\leq \varnothing 3,5$ mm
B	DIN Forme B – Goujure hélicoïdale $\leq \varnothing 3,5$ mm
E	DIN Forme C – Hélice rapide $\leq \varnothing 4,0$ mm

QUEUE

	Queue cylindre ou droite		Queue cylindrique avec tenon
	Queue cylindrique avec 3 méplats		Queue cylindrique DIN 6535 HA
	Queue cylindrique avec extrémité hexagonale		Queue cône Morse
	Queue cylindrique avec extrémité carrée		



CONICITÉ – MILLIMÈTRE (RAPPORT DE CONICITÉ)

1:48 	Conicité (1/4" par pied)	1:50 	Conicité 2% (1 mm par 50 mm)
---	--------------------------	--	------------------------------



ALÉSOIRS ET FRAISES À CHANFREINER – RECHERCHE PAR MATÉRIAU D'OUTIL







Matériaux

Acier rapide	 HSS	Un acier rapide moyennement allié qui présente une bonne usinabilité et de bonnes performances. L'acier rapide présente des caractéristiques de dureté, de ténacité et de résistance à l'usure qui en font un bon choix pour une large gamme d'applications, notamment pour les forets et les tarauds.
Acier rapide au cobalt	 HSS-E	Cet acier rapide contient du cobalt pour une dureté à chaud accrue. La composition du HSCo apporte une bonne combinaison de ténacité et de dureté. Il présente une bonne usinabilité et une bonne résistance à l'usure. Il convient donc à la production de forets, de tarauds, de fraises et d'alésoirs.



























Carbures

Carbures (ou matériaux durs)	 HM	<p>Substrat fritté de la métallurgie des poudres, constitué d'un composite de carbure métallique avec un métal liant. La matière première essentielle est le carbure de tungstène (WC). C'est lui qui confère sa dureté au matériau. Le carbure de tantale (TaC), le carbure de titane (TiC) et le carbure de niobium (NbC) viennent compléter le WC pour obtenir les propriétés spécifiques recherchées. Ces trois matériaux sont appelés des « carbures cubiques ». Le cobalt (Co) sert de liant et assure donc l'homogénéité du matériau final.</p> <p>Les matériaux au carbure se caractérisent généralement par une haute résistance à la compression, une dureté élevée et donc une grande résistance à l'usure, mais aussi une résistance à la flexion et une ténacité limitées. Le carbure est utilisé dans la fabrication de tarauds, d'alésoirs, de fraises, de forets et de fraises à fileter.</p>
-------------------------------------	--	---

Revêtements de surface

Nitride de titane (TiN)	 TiN	Le nitride de titane est un revêtement céramique de couleur or appliqué par dépôt physique en phase vapeur (PVD). Une dureté élevée, associée à un faible frottement, permet d'augmenter considérablement la durée de vie des outils ou d'améliorer les performances de coupe des outils non revêtus. Le revêtement TiN est principalement employé sur les forets et tarauds.
Carbonitride de titane aluminium (AlTiCN)	 AlTiCN	Le carbonitride de titane aluminium (AlTiCN) est un revêtement PVD qui a été spécialement conçu pour répondre aux exigences rigoureuses de l'industrie médicale. Cependant, il convient très bien à certaines opérations des outils de coupe grâce à sa technologie de film mince de haute qualité, et ses excellentes caractéristiques de microdureté et d'adhérence.
Nitride de titane aluminium (TiAlN)	 TiAlN	Le nitride de titane aluminium est un revêtement céramique multi-couche appliqué par procédé PVD. Il confère une ténacité et une stabilité à l'oxydation élevées. Ces propriétés en font un matériau idéal pour des vitesses et avances plus élevées, tout en améliorant la durée de vie des outils. Le TiAlN est utilisé dans le perçage, le taraudage et le fraisage. Il peut également convenir aux usinages sans refroidissement.
Brillant (non revêtu)	 Bright	La finition brillante (surface non revêtue) facilite le glissement des copeaux dans les matériaux non-ferreux ou doux, tout en préservant le tranchant des arêtes de coupe.
Combinaison brillant et traitement vapeur	 Bright ST	La combinaison de la finition brillante et du traitement vapeur apporte des avantages concrets : la surface plus poreuse de l'oxyde bleu attire et retient le fluide de coupe dans le trou tandis que la surface brillante facilite l'évacuation des copeaux. Cette combinaison s'obtient par meulage de la surface brillante après traitement vapeur.
Oxyde de bronze et traitement vapeur	 ST Bronze	La combinaison de l'oxyde de bronze et du traitement vapeur apporte des avantages concrets : la surface plus poreuse de l'oxyde bleu attire et retient le fluide de coupe dans le trou tandis que la surface couleur bronze facilite l'évacuation des copeaux. Ces deux traitements de surface protègent efficacement l'outil. Pour réaliser cette combinaison, deux cycles de trempe sont nécessaires.



Code de matériau du corps (BMC)		HM	HM	HM	HM	HM	HSS	HSS	HSS	HSS-E	HSS	HSS	HSS	HSS
Revêtement		Bright	Bright	Bright	Bright	Bright	Bright ST	Bright		Bright ST	Bright ST	Bright ST	Bright	ST Bronze
Groupe standard de base (BSG)		DIN 8093	DIN 8093	DIN 8050	DIN 8094	DIN 8051	DIN 206	DORMER	DORMER	BS 328	BS 328	DIN 9	DIN 9	ANSI
Sens (direction de coupe)		R	R	R	R	R	R	R		R	R	R	R	R
Queue														
Angle d'application														
Forme d'alésoir		B	B	A	B	A	B			B	A	A	B	
Tolérance de trou réalisable (TCHA)		H7	$\begin{matrix} \phi.95-5.5 \\ +0.004 \\ \phi5.51-12 \\ +0.005 \end{matrix}$	H7	H7	H7	H7			H7				
Pente cônica - millimètre (conicité)										1:48	1:50	1:50		
Code de famille de produits		B400	B481	B441	B411	B442	B100	B334	B335	B901	B301	B903	B952	B122
		1.00 - 20.00	0.98 - 12.05	10.00 - 20.00	5.00 - 30.00	10.00 - 20.00	1.50 - 50.00	N000 - N16	N000BLADES - N16NUT	1.50 - 1/2	1/16 - 1/2	1.50 - 20.00	1.20 - 50.00	3/8 - 1.1/16
		 200	 201	 203	 204	 205	 206	 208	 209	 210	 211	 212	 213	 214
P	P1	■	■	■	■	■	■	■	■	■	■	■	■	■
	P2	■	■	■	■	■	■	■	■	■	■	■	■	■
	P3	■	■	■	■	■	■	■	■	■	■	■	■	■
	P4	■	■	■	■	■	■	■	■	■	■	■	■	■
M	M1	■	■	■	■	■	■	■	■	■	■	■	■	■
	M2	■	■	■	■	■	■	■	■	■	■	■	■	■
	M3													
	M4													
K	K1	■	■	■	■	■	■	■	■	■	■	■	■	■
	K2	■	■	■	■	■	■	■	■	■	■	■	■	■
	K3	■	■	■	■	■	■	■	■	■	■	■	■	■
	K4													
	K5	■	■	■	■	■	■	■	■	■	■	■	■	■
N	N1	■	■	■	■	■	■	■	■	■	■	■	■	■
	N2	■	■	■	■	■	■	■	■	■	■	■	■	■
	N3	■	■	■	■	■	■	■	■	■	■	■	■	■
	N4	■	■	■	■	■	■	■	■	■	■	■	■	■
	N5													
S	S1													
	S2													
	S3													
	S4													
H	H1													
	H2													
	H3													
	H4													

■ Utilisation principale ■ Utilisation possible



	HSS-E	HSS-E	HSS-E	HSS-E	HSS-E	HSS-E	HSS	HSS-E	HSS-E	HSS-E		HM	HSS	HSS
	Bright	Bright	Bright	Bright	Bright	Bright ST	Bright ST	Bright	Bright ST	Bright		Bright	Bright	TIN
	DIN 2179	DIN 212	DIN 212	DIN 212	DIN 208	BS 328	DIN 311	DIN 2180	DIN 219	DIN 217		DIN 335C	DIN 334C	DIN 334C
		B	B	E	B	B		B						
	H7		$\begin{matrix} \phi_{-0.95-5.5} \\ +0.004 \\ \phi_{5.51-12} \\ +0.005 \end{matrix}$	H7	H7	H7	k11	H7						
	1:50							1:50						
	B953	B180	B170	B157	B161	B101	B121	B954	B955	B956	B957	G400	G135	G335
	1.00 - 12.00	1.50 - 20.00	0.98 - 12.00	2.00 - 20.00	3.00 - 50.00	3.00 - 2"	10.00 - 30.00	5.00 - 30.00	25.00 - 80.00	13.00 - 40.00	N3DRIVER - N9WASHER	6.30 - 31.00	6.30 - 25.00	6.30 - 25.00
	215	216	218	220	221	222	224	225	226	227	228	229	230	231
P1	■	■	■	■	■	■	■	■	■			■	■	■
P2	■	■	■	■	■	■	■	■	■			■	■	■
P3	■	■	■	■	■	■	■	■	■			■	■	■
P4	■	■	■	■	■	■	■	■	■			■	■	■
M1	■	■	■	■	■	■		■	■			■	■	■
M2	■	■	■	■	■			■	■			■	■	■
M3												■		■
M4												■		
K1	■	■	■		■	■	■	■	■			■	■	■
K2	■	■	■		■	■	■	■	■			■	■	■
K3	■	■	■		■	■	■	■	■			■	■	■
K4												■	■	■
K5												■	■	■
N1	■	■	■	■	■	■	■	■	■			■	■	■
N2	■	■	■	■	■	■	■	■	■			■	■	■
N3	■	■	■	■	■	■	■	■	■			■	■	■
N4	■	■	■		■	■	■	■	■			■	■	■
N5														
S1												■		
S2												■		
S3												■		
S4												■		
H1												■		
H2												■		
H3												■		
H4												■		

■ Utilisation principale □ Utilisation possible



Code de matériau du corps (BMC)		HSS	HSS	HSS	HSS-E	HSS	HSS	HSS	HSS	HSS	HSS-E	HSS-E	HSS
Revêtement		Bright	Bright	Bright	Bright	Bright	TiAlN	Bright	TiAlN	Bright	AlTiCN	Bright	Bright
Groupe standard de base (BSG)		DIN 334D	DIN 335C	DORMER	DORMER	DIN 335C	DIN 335C	DIN 335C	DIN 335C	DIN 335C	DIN 335C	DORMER	DORMER
Sens (direction de coupe)		R	R	R	R	R	R	R	R	R	R	R	R
Queue													
Angle d'application		60°	82°	90°	90°	90°	90°	90°	90°	90°	90°	90°	90°
Forme d'alésoir													
Tolérance de trou réalisable (TCHA)													
Pente conique - millimètre (conicité)													
Code de famille de produits		G137	G154	G129	G149	G136	G560	G106	G506	G142	G570	G107	G600
		16.00 - 80.00	6.30 - 25.00	6.00 - 31.50	5.00 - 50.00	4.30 - 31.00	6.30 - 31.00	6.30 - 50.00	6.30 - 50.00	4.80 - 31.00	6.30 - 31.00	6.30 - 20.50	6.30 - 25.00
P	P1	■	■	■	■	■	■	■	■	■	■	■	■
	P2	■	■	■	■	■	■	■	■	■	■	■	■
	P3	■	■	■	■	■	■	■	■	■	■	■	■
	P4	■	■	■	■	■	■	■	■	■	■	■	■
M	M1	■	■	■	■	■	■	■	■	■	■	■	■
	M2	■	■	■	■	■	■	■	■	■	■	■	■
	M3									■	■	■	■
	M4									■	■	■	■
K	K1	■	■	■	■	■	■	■	■	■	■	■	■
	K2	■	■	■	■	■	■	■	■	■	■	■	■
	K3	■	■	■	■	■	■	■	■	■	■	■	■
	K4							■	■		■	■	■
	K5	■	■	■	■	■	■	■	■	■	■	■	■
N	N1	■	■	■	■	■	■	■	■	■	■	■	■
	N2	■	■	■	■	■	■	■	■	■	■	■	■
	N3	■	■	■	■	■	■	■	■	■	■	■	■
	N4	■	■	■	■	■	■	■	■	■	■	■	■
	N5									■			
S	S1												
	S2												
	S3												
	S4												
H	H1												
	H2												
	H3												
	H4												

■ Utilisation principale ■ Utilisation possible

HSS	HSS	HSS	HSS	HSS	HSS
Bright	Bright	TiN	TiAlN	Bright	Bright
DIN 335A	DIN 335D	DIN 335D	DIN 335C	DORMER	DIN 373
90°	90°	90°	100°	20°	180°



G132	G138	G338	G171	G314	G125	G236
------	------	------	------	------	------	------

8.00 - 20.00	25.00 - 80.00	25.00 - 63.00	6.30 - 25.00	4.00 - 9.00	6.50 - 20.00	Set
--------------	---------------	---------------	--------------	-------------	--------------	-----

244	245	246	247	248	249	250
-----	-----	-----	-----	-----	-----	-----

P1	■	■	■	■	■	
P2	▣	■	■	■	▣	■
P3	▣	▣	■	■	▣	▣
P4	■	▣	■	■	▣	▣
M1		▣	▣	▣	▣	▣
M2		▣	▣	▣	▣	▣
M3	▣					
M4	▣					
K1	■	▣	■	■	▣	▣
K2	▣	▣	■	■	▣	▣
K3	▣	▣	■	■	▣	▣
K4	▣		▣	▣	▣	▣
K5	▣	▣	■	■	▣	▣
N1	▣	▣	■	▣	■	■
N2	■	▣	■	■	▣	▣
N3	▣	■	■	■	■	■
N4	▣	▣	▣	▣	■	▣
N5						
S1						
S2						
S3						
S4						
H1						
H2						
H3						
H4						



B400



Alésoir machine en carbure à queue cylindrique, précision H7, finition brillante

Alésoir conçu pour fournir une finition dans les limites de la tolérance des trous H7. Offre des performances supérieures et une durée de vie prolongée de l'outil lors de l'alésage de matériaux durs et abrasifs. La conception des goujures en spirale espacées inégalement réduit les vibrations et améliore la cylindricité, la taille et la finition de surface des trous.

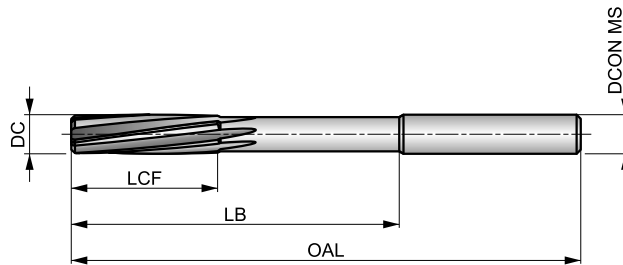

HM	Bright	DIN 8093
R		B
H7		

Adéquation du groupe de matériaux de la pièce, valeurs de départ pour la vitesse de coupe (m/min) et code Alpha d'avance. Les tableaux d'avances par tour se trouvent à partir de la page 251.

P1.1 ■ 23 B	P1.2 ■ 26 B	P1.3 ■ 27 B	P2.1 ■ 20 B	P2.2 ■ 18 B	P2.3 ■ 16 C	P3.1 ■ 16 B	P3.2 ■ 13 B	P3.3 ■ 11 C	P4.1 ■ 10 B	P4.2 ■ 8 C	P4.3 ■ 7 C	M1.1 ■ 10 C	M1.2 ■ 8 C
M2.1 ■ 19 C	M2.2 ■ 17 C	M2.3 ■ 16 B	K1.1 ■ 20 D	K1.2 ■ 15 D	K1.3 ■ 11 D	K2.1 ■ 21 D	K2.2 ■ 17 D	K2.3 ■ 14 D	K3.1 ■ 18 D	K3.2 ■ 14 D	K3.3 ■ 11 D	K5.1 ■ 19 D	K5.2 ■ 15 D
K5.3 ■ 11 D	N1.1 ■ 60 D	N1.2 ■ 45 D	N1.3 ■ 30 D	N2.1 ■ 38 D	N2.2 ■ 35 D	N2.3 ■ 25 D	N3.1 ■ 64 E	N3.2 ■ 38 E	N3.3 ■ 19 E	N4.1 ■ 35 C	N4.2 ■ 30 C		

DCON MS tolerance h6; DC >= 14 mm pointe carbure.

Produit	DC (mm)	OAL (mm)	LCF (mm)	LB (mm)	NOF	DCON MS (mm)
B4001.0	1.00	34.0	5.5	15.00	3	1.00
B4001.2	1.20	38.0	7.5	16.50	3	1.20
B4001.4	1.40	40.0	8.0	18.00	3	1.50
B4001.5	1.50	40.0	8.0	18.00	3	1.50
B4001.6	1.60	43.0	9.0	20.00	3	1.60
B4001.8	1.80	46.0	10.0	22.00	4	1.80
B4002.0	2.00	49.0	11.0	24.00	4	2.00
B4002.2	2.20	53.0	12.0	25.00	4	2.20
B4002.5	2.50	57.0	14.0	29.00	4	2.50
B4002.8	2.80	61.0	15.0	33.00	6	3.00
B4003.0	3.00	61.0	15.0	33.00	6	3.00
B4003.2	3.20	65.0	16.0	37.00	6	3.20
B4003.5	3.50	70.0	18.0	42.00	6	3.50
B4004.0	4.00	75.0	19.0	47.00	6	4.00

Produit	DC (mm)	OAL (mm)	LCF (mm)	LB (mm)	NOF	DCON MS (mm)
B4004.5	4.50	80.0	21.0	52.00	6	4.50
B4005.0	5.00	86.0	23.0	58.00	6	5.00
B4005.5	5.50	93.0	26.0	57.00	6	5.60
B4006.0	6.00	93.0	26.0	57.00	6	5.60
B4006.5	6.50	101.0	28.0	65.00	6	6.30
B4007.0	7.00	109.0	31.0	73.00	6	7.10
B4008.0	8.00	117.0	33.0	81.00	6	8.00
B4009.0	9.00	125.0	36.0	85.00	6	9.00
B40010.0	10.00	133.0	38.0	93.00	6	10.00
B40012.0	12.00	151.0	44.0	111.00	6	10.00
B40014.0	14.00	160.0	47.0	115.00	6	12.50
B40016.0	16.00	170.0	52.0	125.00	6	12.50
B40018.0	18.00	182.0	56.0	137.00	6	14.00
B40020.0	20.00	195.0	60.0	147.00	6	16.00



B481



Alésoir machine en carbure à queue cylindrique - Incréments de 0,01 mm, finition brillante

Alésoir à queue cylindrique pour de hautes performances en usinage CNC. Les arêtes en carbure de première qualité améliorent considérablement les performances et prolongent la durée de vie de l'outil lors de l'alésage de matériaux durs et abrasifs. Espacement extrêmement inégal des goujures pour réduire les vibrations.

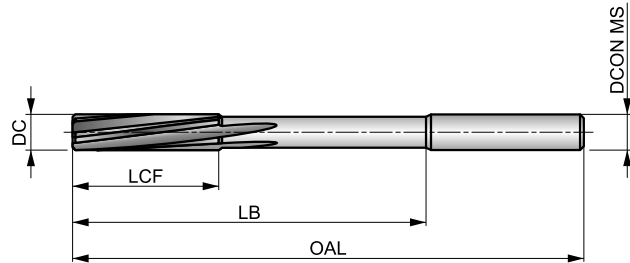

HM	Bright	DIN 8093
R	DIN 6535HA	B
$\begin{matrix} \phi .95-5.5 \\ +0.004 \\ \phi 5.51-12 \\ +0.005 \end{matrix}$		

Adéquation du groupe de matériaux de la pièce, valeurs de départ pour la vitesse de coupe (m/min) et code Alpha d'avance. Les tableaux d'avances par tour se trouvent à partir de la page 251.

P1.1 ■ 23 B	P1.2 ■ 26 B	P1.3 ■ 27 B	P2.1 ■ 20 B	P2.2 ■ 18 B	P2.3 ■ 16 C	P3.1 ■ 16 B	P3.2 ■ 13 B	P3.3 ■ 11 C	P4.1 ■ 10 B	P4.2 ■ 8 C	P4.3 ■ 7 C	M1.1 ■ 10 C	M1.2 ■ 8 C
M2.1 ■ 9 C	M2.2 ■ 7 C	M2.3 ■ 6 B	K1.1 ■ 20 D	K1.2 ■ 15 D	K1.3 ■ 11 D	K2.1 ■ 21 D	K2.2 ■ 17 D	K2.3 ■ 14 D	K3.1 ■ 18 D	K3.2 ■ 14 D	K3.3 ■ 11 D	K5.1 ■ 19 D	K5.2 ■ 15 D
K5.3 ■ 11 D	N1.1 ■ 60 D	N1.2 ■ 45 D	N1.3 ■ 30 D	N2.1 ■ 38 D	N2.2 ■ 35 D	N2.3 ■ 25 D	N3.1 ■ 64 E	N3.2 ■ 38 E	N3.3 ■ 19 E	N4.1 ■ 35 C	N4.2 ■ 30 C		

DCON MS tolérance h6.

Produit	DC	OAL	LCF	LB	NOF	DCON MS
	(mm)	(mm)	(mm)	(mm)		(mm)
B4810.98	0.98	50.0	6.0	28.00	3	3.00
B4810.99	0.99	50.0	6.0	28.00	3	3.00
B4811.00	1.00	50.0	6.0	28.00	3	3.00
B4811.01	1.01	50.0	6.0	28.00	3	3.00
B4811.02	1.02	50.0	6.0	28.00	3	3.00
B4811.03	1.03	50.0	6.0	28.00	3	3.00
B4811.48	1.48	50.0	9.0	28.00	3	3.00
B4811.49	1.49	50.0	9.0	28.00	3	3.00
B4811.50	1.50	50.0	9.0	28.00	3	3.00
B4811.51	1.51	50.0	10.0	28.00	3	3.00
B4811.52	1.52	50.0	10.0	28.00	3	3.00
B4811.53	1.53	50.0	10.0	28.00	3	3.00
B4811.98	1.98	50.0	12.0	28.00	4	3.00
B4811.99	1.99	50.0	12.0	28.00	4	3.00
B4812.00	2.00	50.0	12.0	28.00	4	3.00
B4812.01	2.01	50.0	12.0	28.00	4	3.00
B4812.02	2.02	50.0	12.0	28.00	4	3.00
B4812.03	2.03	50.0	12.0	28.00	4	3.00
B4812.48	2.48	60.0	16.0	28.00	4	3.00
B4812.49	2.49	60.0	16.0	28.00	4	3.00
B4812.50	2.50	60.0	16.0	28.00	4	3.00
B4812.51	2.51	60.0	16.0	28.00	4	3.00
B4812.52	2.52	60.0	16.0	28.00	4	3.00
B4812.53	2.53	60.0	16.0	28.00	4	3.00
B4812.97	2.97	65.0	17.0	28.00	6	4.00
B4812.98	2.98	65.0	17.0	28.00	6	4.00
B4812.99	2.99	65.0	17.0	28.00	6	4.00

Produit	DC	OAL	LCF	LB	NOF	DCON MS
	(mm)	(mm)	(mm)	(mm)		(mm)
B4813.00	3.00	65.0	17.0	28.00	6	4.00
B4813.01	3.01	65.0	17.0	28.00	6	4.00
B4813.02	3.02	65.0	17.0	28.00	6	4.00
B4813.03	3.03	65.0	17.0	28.00	6	4.00
B4813.97	3.97	75.0	19.0	28.00	6	4.00
B4813.98	3.98	75.0	19.0	28.00	6	4.00
B4813.99	3.99	75.0	19.0	28.00	6	4.00
B4814.00	4.00	75.0	19.0	28.00	6	4.00
B4814.01	4.01	75.0	19.0	28.00	6	4.00
B4814.02	4.02	75.0	19.0	28.00	6	4.00
B4814.03	4.03	75.0	19.0	28.00	6	4.00
B4814.97	4.97	93.0	23.0	36.00	6	6.00
B4814.98	4.98	93.0	23.0	36.00	6	6.00
B4814.99	4.99	93.0	23.0	36.00	6	6.00
B4815.00	5.00	93.0	23.0	36.00	6	6.00
B4815.01	5.01	93.0	23.0	36.00	6	6.00
B4815.02	5.02	93.0	23.0	36.00	6	6.00
B4815.03	5.03	93.0	23.0	36.00	6	6.00
B4815.97	5.97	93.0	26.0	36.00	6	6.00
B4815.98	5.98	93.0	26.0	36.00	6	6.00
B4815.99	5.99	93.0	26.0	36.00	6	6.00
B4816.00	6.00	93.0	26.0	36.00	6	6.00
B4816.01	6.01	93.0	26.0	36.00	6	6.00
B4816.02	6.02	93.0	26.0	36.00	6	6.00
B4816.03	6.03	93.0	26.0	36.00	6	6.00
B4817.97	7.97	117.0	33.0	36.00	6	8.00
B4817.98	7.98	117.0	33.0	36.00	6	8.00



Produit	DC	OAL	LCF	LB	NOF	DCON MS
	(mm)	(mm)	(mm)	(mm)		(mm)
B4817.99	7.99	117.0	33.0	36.00	6	8.00
B4818.00	8.00	117.0	33.0	36.00	6	8.00
B4818.01	8.01	117.0	33.0	36.00	6	8.00
B4818.02	8.02	117.0	33.0	36.00	6	8.00
B4818.03	8.03	117.0	33.0	36.00	6	8.00
B4818.04	8.04	117.0	33.0	36.00	6	8.00
B4819.97	9.97	133.0	38.0	40.00	6	10.00
B4819.98	9.98	133.0	38.0	40.00	6	10.00
B4819.99	9.99	133.0	38.0	40.00	6	10.00
B48110.00	10.00	133.0	38.0	40.00	6	10.00
B48110.01	10.01	133.0	38.0	40.00	6	10.00
B48110.02	10.02	133.0	38.0	40.00	6	10.00

Produit	DC	OAL	LCF	LB	NOF	DCON MS
	(mm)	(mm)	(mm)	(mm)		(mm)
B48110.03	10.03	133.0	38.0	40.00	6	10.00
B48110.04	10.04	133.0	38.0	40.00	6	10.00
B48110.05	10.05	133.0	38.0	40.00	6	10.00
B48111.97	11.97	151.0	44.0	45.00	6	12.00
B48111.98	11.98	151.0	44.0	45.00	6	12.00
B48111.99	11.99	151.0	44.0	45.00	6	12.00
B48112.00	12.00	151.0	44.0	45.00	6	12.00
B48112.01	12.01	151.0	44.0	45.00	6	12.00
B48112.02	12.02	151.0	44.0	45.00	6	12.00
B48112.03	12.03	151.0	44.0	45.00	6	12.00
B48112.04	12.04	151.0	44.0	45.00	6	12.00
B48112.05	12.05	151.0	44.0	45.00	6	12.00



B441



Alésoir machine en carbure à queue cylindrique, précision H7, finition brillante

Alésoir avec extrémité en carbure brasée offrant une durée de vie prolongée et des performances supérieures lors de l'alésage de trous dans les limites de la tolérance H7. La conception extrêmement inégale des goujures réduit les vibrations et améliore la cylindricité, l'état de surface et la taille des trous. L'outil offre de grandes performances sur machines CNC.

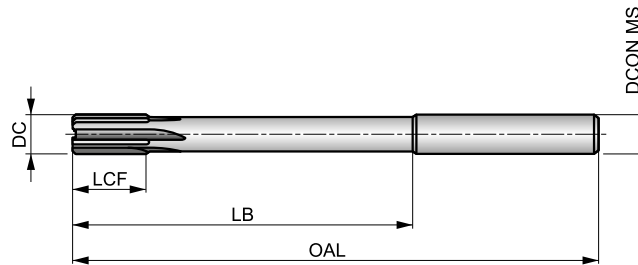

HM	Bright	DIN 8050
R		A
H7		

Adéquation du groupe de matériaux de la pièce, valeurs de départ pour la vitesse de coupe (m/min) et code Alpha d'avance. Les tableaux d'avances par tour se trouvent à partir de la page 251.

P1.1 ■ 23 B	P1.2 ■ 26 B	P1.3 ■ 27 B	P2.1 ■ 20 B	P2.2 ■ 18 B	P2.3 ■ 16 C	P3.1 ■ 16 B	P3.2 ■ 13 B	P3.3 ■ 11 C	P4.1 ■ 10 B	P4.2 ■ 8 C	P4.3 ■ 7 C	M1.1 ▣ 10 C	M1.2 ▣ 8 C
M2.1 ▣ 9 C	M2.2 ▣ 7 C	M2.3 ▣ 6 B	K1.1 ■ 20 D	K1.2 ■ 15 D	K1.3 ■ 11 D	K2.1 ■ 21 D	K2.2 ■ 17 D	K2.3 ■ 14 D	K3.1 ■ 18 D	K3.2 ■ 14 D	K3.3 ■ 11 D	K5.1 ■ 19 D	K5.2 ■ 15 D
K5.3 ■ 11 D	N1.1 ▣ 60 D	N1.2 ■ 45 D	N1.3 ■ 30 D	N2.1 ■ 38 D	N2.2 ■ 35 D	N2.3 ■ 25 D	N3.1 ■ 64 E	N3.2 ■ 38 E	N3.3 ▣ 19 E	N4.1 ▣ 35 C	N4.2 ▣ 30 C		

DCON MS tolerance h9; pointe carbure.

Produit	DC (mm)	OAL (mm)	LCF (mm)	LB (mm)	NOF	DCON MS (mm)
B44110.0	10.00	133.0	19.0	87.00	6	10.00
B44111.0	11.00	142.0	19.0	96.00	6	10.00
B44112.0	12.00	151.0	19.0	105.00	6	10.00
B44113.0	13.00	151.0	19.0	105.00	6	10.00
B44114.0	14.00	160.0	19.0	110.00	6	12.50
B44115.0	15.00	162.0	19.0	112.00	6	12.50
B44116.0	16.00	170.0	22.0	120.00	6	12.50
B44117.0	17.00	175.0	22.0	123.00	6	14.00
B44118.0	18.00	182.0	22.0	130.00	6	14.00
B44119.0	19.00	189.0	22.0	131.00	6	16.00
B44120.0	20.00	195.0	22.0	137.00	6	16.00



B411



Alésoir machine en carbure à queue cône morse pour précision H7, finition brillante

Alésoir avec extrémité en carbure brasée améliorant considérablement les performances et prolongeant la durée de vie de l'outil lorsque vous alésez des matériaux durs et abrasifs. Les goujures en spirale présentent un espacement inégal entre elles, ce qui réduit efficacement les vibrations et améliore la cylindricité, la taille et la finition des trous.

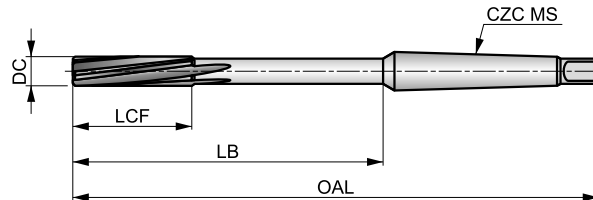

HM	Bright	DIN 8094
R		B
H7		

Adéquation du groupe de matériaux de la pièce, valeurs de départ pour la vitesse de coupe (m/min) et code Alpha d'avance. Les tableaux d'avances par tour se trouvent à partir de la page 251.

P1.1 ■ 23 B	P1.2 ■ 26 B	P1.3 ■ 27 B	P2.1 ■ 20 B	P2.2 ■ 18 B	P2.3 ■ 16 C	P3.1 ■ 16 B	P3.2 ■ 13 B	P3.3 ■ 11 C	P4.1 ■ 10 B	P4.2 ■ 8 C	P4.3 ■ 7 C	M1.1 ▣ 10 C	M1.2 ▣ 8 C
M2.1 ▣ 9 C	M2.2 ▣ 7 C	M2.3 ▣ 6 B	K1.1 ■ 20 D	K1.2 ■ 15 D	K1.3 ■ 11 D	K2.1 ■ 21 D	K2.2 ■ 17 D	K2.3 ■ 14 D	K3.1 ■ 18 D	K3.2 ■ 14 D	K3.3 ■ 11 D	K5.1 ■ 19 D	K5.2 ■ 15 D
K5.3 ■ 11 D	N1.1 ▣ 60 D	N1.2 ■ 45 D	N1.3 ■ 30 D	N2.1 ■ 38 D	N2.2 ■ 35 D	N2.3 ■ 25 D	N3.1 ■ 64 E	N3.2 ■ 38 E	N3.3 ▣ 19 E	N4.1 ▣ 35 C	N4.2 ▣ 30 C		

DC <= 16mm tête carbure; DC > 16mm pointe carbure.

Produit	DC (mm)	OAL (mm)	LCF (mm)	LB (mm)	NOF	CZC MS
B4115.0	5.00	133.0	23.0	67.50	6	MK 1
B4116.0	6.00	138.0	26.0	72.50	6	MK 1
B4117.0	7.00	150.0	31.0	84.50	6	MK 1
B4118.0	8.00	156.0	33.0	90.50	6	MK 1
B4119.0	9.00	162.0	36.0	96.50	6	MK 1
B41110.0	10.00	168.0	38.0	102.50	6	MK 1
B41112.0	12.00	182.0	44.0	116.50	6	MK 1
B41114.0	14.00	189.0	47.0	123.50	8	MK 1
B41115.0	15.00	204.0	50.0	124.00	8	MK 2
B41116.0	16.00	210.0	52.0	130.00	8	MK 2
B41117.0	17.00	214.0	54.0	134.00	6	MK 2
B41118.0	18.00	219.0	56.0	139.00	6	MK 2
B41119.0	19.00	223.0	58.0	143.00	6	MK 2
B41120.0	20.00	228.0	60.0	148.00	6	MK 2
B41122.0	22.00	237.0	64.0	157.00	6	MK 2
B41124.0	24.00	268.0	68.0	169.00	8	MK 3
B41125.0	25.00	268.0	68.0	169.00	8	MK 3
B41126.0	26.00	273.0	70.0	174.00	8	MK 3
B41130.0	30.00	281.0	73.0	182.00	8	MK 3



B442



Alésoir machine en carbure à queue conique et pour précision H7, finition brillante

Alésoir conçu avec une denture extrêmement inégale afin de réduire les vibrations et améliorer la taille du trou, la cylindricité et la finition de surface des trous. Le chanfrein à 45° assure un positionnement et un centrage précis pour une qualité de trou et des performances améliorées. La pointe en carbure brasée offre une durée de vie prolongée et des performances supérieures.

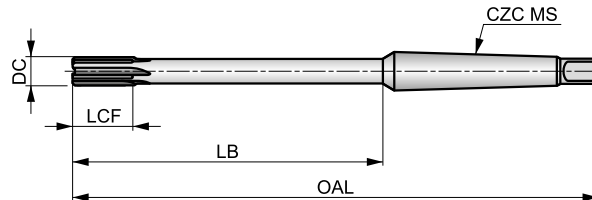

HM	Bright	DIN 8051
R		A
H7		

Adéquation du groupe de matériaux de la pièce, valeurs de départ pour la vitesse de coupe (m/min) et code Alpha d'avance. Les tableaux d'avances par tour se trouvent à partir de la page 251.

P1.1 ■ 23 B	P1.2 ■ 26 B	P1.3 ■ 27 B	P2.1 ■ 20 B	P2.2 ■ 18 B	P2.3 ■ 16 C	P3.1 ■ 16 B	P3.2 ■ 13 B	P3.3 ■ 11 C	P4.1 ■ 10 B	P4.2 ■ 8 C	P4.3 ■ 7 C	M1.1 ■ 10 C	M1.2 ■ 8 C
M2.1 ■ 9 C	M2.2 ■ 7 C	M2.3 ■ 6 B	K1.1 ■ 20 D	K1.2 ■ 15 D	K1.3 ■ 11 D	K2.1 ■ 21 D	K2.2 ■ 17 D	K2.3 ■ 14 D	K3.1 ■ 18 D	K3.2 ■ 14 D	K3.3 ■ 11 D	K5.1 ■ 19 D	K5.2 ■ 15 D
K5.3 ■ 11 D	N1.1 ■ 60 D	N1.2 ■ 45 D	N1.3 ■ 30 D	N2.1 ■ 38 D	N2.2 ■ 35 D	N2.3 ■ 25 D	N3.1 ■ 64 E	N3.2 ■ 38 E	N3.3 ■ 19 E	N4.1 ■ 35 C	N4.2 ■ 30 C		

Produit	DC (mm)	OAL (mm)	LCF (mm)	LB (mm)	NOF	CZC MS
B44210.0	10.00	168.0	19.0	102.50	6	MK 1
B44212.0	12.00	182.0	19.0	116.50	6	MK 1
B44214.0	14.00	189.0	19.0	123.50	6	MK 1
B44215.0	15.00	204.0	19.0	124.00	6	MK 2
B44216.0	16.00	210.0	22.0	130.00	6	MK 2
B44217.0	17.00	214.0	22.0	134.00	6	MK 2
B44218.0	18.00	219.0	22.0	139.00	6	MK 2
B44219.0	19.00	223.0	22.0	143.00	6	MK 2
B44220.0	20.00	228.0	22.0	148.00	6	MK 2



B100



Alésoir à main en HSS à queue cylindrique pour précision H7, finition brillante et ST

Alésoir principalement conçu pour être utilisé à la main. Il est doté d'une hélice à gauche rectifiée avec précision et d'une coupe à droite (sens des aiguilles d'une montre) pour un alésage en douceur, générant une taille de trou plus précise et une bonne finition de surface. Convient à l'alésage de nombreux matériaux, y compris les aciers.

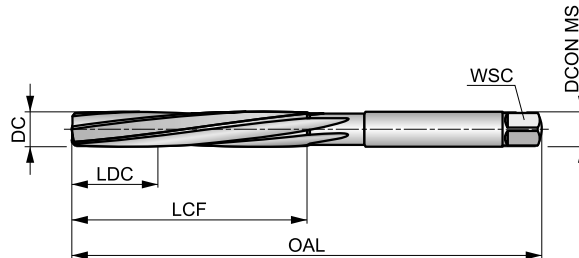

HSS	Bright ST	DIN 206
R		B
H7		

Adéquation du groupe de matériaux de la pièce, valeurs de départ pour la vitesse de coupe (m/min) et code Alpha d'avance. Les tableaux d'avances par tour se trouvent à partir de la page 251.

P1.1	P1.2	P1.3	P2.1	P2.2	P2.3	P3.1	P3.2	P3.3	P4.1	P4.2	P4.3	M1.1	M1.2
■	■	■	■	■	■	■	■	■	■	■	■	■	■
M2.1	K1.1	K1.2	K1.3	K2.1	K2.2	K2.3	K3.1	K3.2	N1.1	N1.2	N1.3	N2.1	N2.2
■	■	■	■	■	■	■	■	■	■	■	■	■	■
N2.3	N3.1	N3.2	N3.3	N4.1	N4.2								
■	■	■	■	■	■								

DCON MS tolérance e9.

Produit	DC	DC	OAL	LCF	LDC	NOF	WSC	DCON MS
	(inch)	(mm)	(mm)	(mm)	(mm)		(mm)	(mm)
B1001.5	–	1.50	41.0	20.0	5.00	3	1.12	1.50
B1001/16	1/16	1.59	41.0	20.0	5.00	3	1.12	1.59
B1001.6	–	1.60	44.0	21.0	5.00	3	1.25	1.60
B1005/64	5/64	1.98	47.0	23.0	6.00	4	1.40	1.98
B1002.0	–	2.00	50.0	25.0	6.00	4	1.60	2.00
B1003/32	3/32	2.38	54.0	27.0	7.00	4	1.80	2.38
B1002.5	–	2.50	58.0	29.0	7.00	4	2.10	2.50
B1007/64	7/64	2.78	62.0	31.0	8.00	6	2.10	2.78
B1003.0	–	3.00	62.0	31.0	8.00	6	2.40	3.00
B1001/8	1/8	3.18	66.0	33.0	8.00	6	2.40	3.18
B1003.2	–	3.20	66.0	33.0	8.00	6	2.40	3.20
B1003.5	–	3.50	71.0	35.0	9.00	6	2.70	3.50
B1009/64	9/64	3.57	71.0	35.0	9.00	6	2.70	3.57
B1005/32	5/32	3.97	76.0	38.0	10.00	6	3.00	3.97
B1004.0	–	4.00	76.0	38.0	10.00	6	3.00	4.00
B10011/64	11/64	4.37	81.0	41.0	10.00	6	3.40	4.37
B1004.5	–	4.50	81.0	41.0	10.00	6	3.40	4.50
B1003/16	3/16	4.76	87.0	44.0	11.00	6	3.80	4.76
B1005.0	–	5.00	87.0	44.0	11.00	6	3.80	5.00
B10013/64	13/64	5.16	87.0	44.0	11.00	6	3.80	5.16
B1005.5	–	5.50	93.0	47.0	12.00	6	4.30	5.50
B1007/32	7/32	5.56	93.0	47.0	12.00	6	4.30	5.56
B10015/64	15/64	5.95	93.0	47.0	12.00	6	4.90	5.95
B1006.0	–	6.00	93.0	47.0	12.00	6	4.90	6.00
B1001/4	1/4	6.35	100.0	50.0	13.00	6	4.90	6.35
B1006.5	–	6.50	100.0	50.0	13.00	6	4.90	6.50
B10017/64	17/64	6.75	107.0	54.0	14.00	6	5.50	6.75



Produit	DC	DC	OAL	LCF	LDC	NOF	WSC	DCON MS
	(inch)	(mm)	(mm)	(mm)	(mm)		(mm)	(mm)
B1007.0	–	7.00	107.0	54.0	14.00	6	5.50	7.00
B1009/32	9/32	7.14	107.0	54.0	14.00	6	6.20	7.14
B1007.5	–	7.50	107.0	54.0	14.00	6	6.20	7.50
B10019/64	19/64	7.54	115.0	58.0	15.00	6	6.20	7.54
B1005/16	5/16	7.94	115.0	58.0	15.00	6	6.20	7.94
B1008.0	–	8.00	115.0	58.0	15.00	6	6.20	8.00
B10021/64	21/64	8.33	115.0	58.0	15.00	6	7.00	8.33
B1008.5	–	8.50	115.0	58.0	15.00	6	7.00	8.50
B10011/32	11/32	8.73	124.0	62.0	16.00	6	7.00	8.73
B1009.0	–	9.00	124.0	62.0	16.00	6	7.00	9.00
B10023/64	23/64	9.13	124.0	62.0	16.00	6	8.00	9.13
B1009.5	–	9.50	124.0	62.0	16.00	6	8.00	9.50
B1003/8	3/8	9.52	124.0	62.0	17.00	6	8.00	9.52
B10025/64	25/64	9.92	133.0	66.0	17.00	6	8.00	9.92
B10010.0	–	10.00	133.0	66.0	17.00	6	8.00	10.00
B10013/32	13/32	10.32	133.0	66.0	17.00	6	8.00	10.32
B10010.5	–	10.50	133.0	66.0	17.00	6	8.00	10.50
B10011.0	–	11.00	142.0	71.0	18.00	6	9.00	11.00
B1007/16	7/16	11.11	142.0	71.0	18.00	6	9.00	11.11
B10011.5	–	11.50	142.0	71.0	18.00	6	9.00	11.50
B10012.0	–	12.00	152.0	76.0	19.00	6	9.00	12.00
B10012.5	–	12.50	152.0	76.0	19.00	6	10.00	12.50
B1001/2	1/2	12.70	152.0	76.0	19.00	6	10.00	12.70
B10013.0	–	13.00	152.0	76.0	19.00	6	10.00	13.00
B10017/32	17/32	13.49	163.0	81.0	20.00	8	11.00	13.49
B10013.5	–	13.50	163.0	81.0	20.00	8	11.00	13.50
B10014.0	–	14.00	163.0	81.0	20.00	8	11.00	14.00
B1009/16	9/16	14.29	163.0	81.0	20.00	8	11.00	14.29
B10014.5	–	14.50	163.0	81.0	20.00	8	11.00	14.50
B10015.0	–	15.00	163.0	81.0	20.00	8	12.00	15.00
B10019/32	19/32	15.08	163.0	81.0	22.00	8	12.00	15.08
B1005/8	5/8	15.88	175.0	87.0	22.00	8	12.00	15.88
B10016.0	–	16.00	175.0	87.0	22.00	8	12.00	16.00
B10017.0	–	17.00	175.0	87.0	22.00	8	13.00	17.00
B10011/16	11/16	17.46	188.0	93.0	23.00	8	14.50	17.46
B10018.0	–	18.00	188.0	93.0	23.00	8	14.50	18.00
B10019.0	–	19.00	188.0	93.0	23.00	8	14.50	19.00
B1003/4	3/4	19.05	188.0	93.0	25.00	8	14.50	19.05
B10020.0	–	20.00	201.0	100.0	25.00	8	16.00	20.00
B10013/16	13/16	20.64	201.0	100.0	25.00	8	16.00	20.64
B10021.0	–	21.00	201.0	100.0	25.00	8	16.00	21.00
B10022.0	–	22.00	215.0	107.0	27.00	8	18.00	22.00
B1007/8	7/8	22.22	215.0	107.0	27.00	8	18.00	22.22
B10023.0	–	23.00	215.0	107.0	27.00	8	18.00	23.00
B10024.0	–	24.00	231.0	115.0	29.00	8	18.00	24.00
B10025.0	–	25.00	231.0	115.0	29.00	8	20.00	25.00
B1001	1"	25.40	231.0	115.0	29.00	8	20.00	25.40
B10026.0	–	26.00	231.0	115.0	29.00	8	20.00	26.00
B10027.0	–	27.00	247.0	124.0	31.00	10	22.00	27.00
B10028.0	–	28.00	247.0	124.0	31.00	10	22.00	28.00
B10029.0	–	29.00	247.0	124.0	31.00	10	22.00	29.00
B10030.0	–	30.00	247.0	124.0	31.00	10	24.00	30.00
B10031.0	–	31.00	265.0	133.0	33.00	10	24.00	31.00
B10032.0	–	32.00	265.0	133.0	33.00	10	24.00	32.00
B10033.0	–	33.00	265.0	133.0	33.00	10	26.00	33.00
B10034.0	–	34.00	284.0	142.0	36.00	10	26.00	34.00
B10035.0	–	35.00	284.0	142.0	36.00	10	29.00	35.00
B10036.0	–	36.00	284.0	142.0	36.00	10	29.00	36.00
B10037.0	–	37.00	284.0	142.0	36.00	10	29.00	37.00
B10038.0	–	38.00	305.0	152.0	38.00	10	29.00	38.00
B10039.0	–	39.00	305.0	152.0	38.00	10	32.00	39.00
B10040.0	–	40.00	305.0	152.0	38.00	10	32.00	40.00
B10045.0	–	45.00	326.0	163.0	41.00	12	35.00	45.00
B10050.0	–	50.00	347.0	174.0	44.00	12	39.00	50.00



B334



Alésoir à main expansible en HSS à queue cylindrique

Cet alésoir à main est facilement réglable ce qui permet la finition de nombreux trous de diamètres différents avec un seul alésoir. Avec des lames rectifiées avec précision et une géométrie de goujure droite, on réalise un alésage en douceur et on améliore la taille du trou et l'état de surface. Convient pour l'alésage dans de nombreux matériaux.

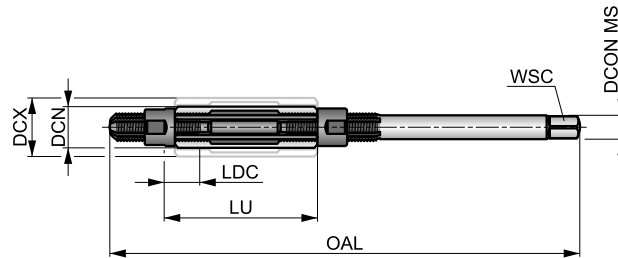

Adéquation du groupe de matériaux de la pièce, valeurs de départ pour la vitesse de coupe (m/min) et code Alpha d'avance. Les tableaux d'avances par tour se trouvent à partir de la page 251.

P1.1	P1.2	P1.3	P2.1	P2.2	P2.3	P3.1	P3.2	P3.3	P4.1	P4.2	P4.3	M1.1	M1.2
■	■	■	■	■	■	■	■	■	■	■	■	■	■
M2.1	K1.1	K1.2	K1.3	K2.1	K2.2	K2.3	K3.1	K3.2	N1.1	N1.2	N1.3	N2.1	N2.2
■	■	■	■	■	■	■	■	■	■	■	■	■	■
N2.3	N3.1	N3.2	N3.3	N4.1	N4.2								
■	■	■	■	■	■								

Produit	Nr.	DCN	DCX	OAL	LU	LDC	NOF	WSC
		(mm)	(mm)	(mm)	(mm)	(mm)		
B334000	000	6.40	7.20	110.0	32.00	7.00	4	3.00
B33400	00	7.20	8.00	110.0	32.00	7.00	4	3.40
B3340	0	8.00	9.00	115.0	34.00	9.00	5	3.80
B3341	1	9.00	10.00	115.0	34.00	9.00	5	4.30
B3342	2	10.00	11.00	115.0	34.00	9.00	5	4.90
B3343	3	11.00	12.00	125.0	35.00	9.00	5	4.90
B3344	4	12.00	13.50	135.0	41.00	9.00	5	6.20
B3345	5	13.50	15.50	146.0	50.00	12.00	5	7.00
B3346	6	15.50	18.00	166.0	60.00	12.00	5	8.00
B3347	7	18.00	21.00	178.0	65.00	15.00	5	9.00
B3348	8	21.00	24.00	195.0	76.00	15.00	5	11.00
B3349	9	24.00	27.50	218.0	82.00	18.00	5	12.00
B33410	10	27.50	31.50	245.0	86.00	18.00	5	14.50
B33411	11	31.50	37.00	280.0	98.00	18.00	6	18.00
B33412	12	37.00	45.00	325.0	108.00	20.00	6	20.00
B33413	13	45.00	55.00	370.0	118.00	20.00	6	26.00
B33414	14	55.00	67.00	400.0	125.00	20.00	6	32.00
B33415	15	67.00	80.00	435.0	140.00	23.00	8	39.00
B33416	16	80.00	95.00	475.0	155.00	23.00	8	49.00



B335

DORMER



Lames en HSS et écrous de rechange pour l'alésoir à main expansible B334

Les écrous et les lames peuvent être achetés séparément et sont chacun disponibles en 19 tailles.

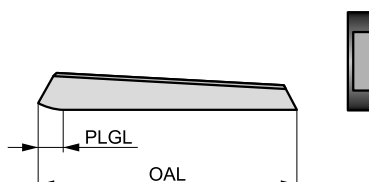

Produit	Nr.	PLGL	OAL
		(mm)	(mm)
B335000BLADES	000	7.00	32.0
B335000NUT	000	–	–
B33500BLADES	00	7.00	32.0
B33500NUT	00	–	–
B3350BLADES	0	9.00	34.0
B3350NUT	0	–	–
B3351BLADES	1	9.00	34.0
B3351NUT	1	–	–
B3352BLADES	2	9.00	34.0
B3352NUT	2	–	–
B3353BLADES	3	9.00	35.0
B3353NUT	3	–	–
B3354BLADES	4	9.00	41.0
B3354NUT	4	–	–
B3355BLADES	5	12.00	50.0
B3355NUT	5	–	–
B3356BLADES	6	12.00	60.0
B3356NUT	6	–	–
B3357BLADES	7	15.00	65.0

Produit	Nr.	PLGL	OAL
		(mm)	(mm)
B3357NUT	7	–	–
B3358BLADES	8	15.00	76.0
B3358NUT	8	–	–
B3359BLADES	9	18.00	82.0
B3359NUT	9	–	–
B33510BLADES	10	18.00	86.0
B33510NUT	10	–	–
B33511BLADES	11	18.00	98.0
B33511NUT	11	–	–
B33512BLADES	12	20.00	108.0
B33512NUT	12	–	–
B33513BLADES	13	20.00	118.0
B33513NUT	13	–	–
B33514BLADES	14	20.00	125.0
B33514NUT	14	–	–
B33515BLADES	15	23.00	140.0
B33515NUT	15	–	–
B33516BLADES	16	23.00	155.0
B33516NUT	16	–	–



B901



Alésoir machine en HSS-E à queue cylindrique, précision H7, finition brillante et ST

Alésoir avec géométrie rectifiée avec précision, hélice à gauche et coupe à droite. Améliore la taille des trous et la finition de surface. L'alésoir a une queue cylindrique pour un alésage de haute performance sur machines. Convient pour l'alésage dans de nombreux matériaux.

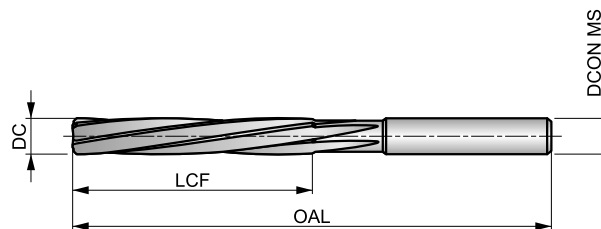

HSS-E	Bright ST	BS 328
R		B
H7		

Adéquation du groupe de matériaux de la pièce, valeurs de départ pour la vitesse de coupe (m/min) et code Alpha d'avance. Les tableaux d'avances par tour se trouvent à partir de la page 251.

P1.1 ■ 15 C	P1.2 ■ 16 C	P1.3 ■ 17 C	P2.1 ■ 13 C	P2.2 ■ 11 C	P2.3 ▧ 10 B	P3.1 ■ 7 B	P3.2 ■ 6 B	P3.3 ▧ 5 B	P4.1 ■ 4 B	P4.2 ▧ 4 B	P4.3 ▧ 3 A	M1.1 ▧ 10 C	M1.2 ▧ 8 C
M2.1 ▧ 9 C	K1.1 ■ 14 E	K1.2 ■ 10 D	K1.3 ▧ 8 D	K2.1 ■ 12 C	K2.2 ■ 10 C	K2.3 ▧ 8 C	K3.1 ▧ 11 C	K3.2 ▧ 8 C	N1.1 ▧ 23 F	N1.2 ■ 17 F	N1.3 ■ 12 F	N2.1 ■ 25 E	N2.2 ■ 22 E
N2.3 ▧ 14 E	N3.1 ■ 34 D	N3.2 ■ 20 E	N3.3 ■ 10 D	N4.1 ▧ 22 B	N4.2 ▧ 21 B								

Produit	DC	DC	OAL	LCF	NOF	DCON MS
	(inch)	(mm)	(mm)	(mm)		(mm)
B9011.5	—	1.50	44.0	21.0	4	1.50
B9011/16	1/16	1.59	44.0	21.0	4	1.59
B9012.0	—	2.00	50.0	25.0	4	2.00
B9013/32	3/32	2.38	58.0	29.0	4	2.38
B9012.5	—	2.50	58.0	29.0	4	2.50
B9013.0	—	3.00	62.0	31.0	4	3.00
B9011/8	1/8	3.18	66.0	33.0	4	3.18
B9013.5	—	3.50	71.0	35.0	4	3.50
B9015/32	5/32	3.97	76.0	38.0	6	3.97
B9014.0	—	4.00	76.0	38.0	6	4.00
B9014.5	—	4.50	81.0	41.0	6	4.50
B9013/16	3/16	4.76	87.0	44.0	6	4.76
B9015.0	—	5.00	87.0	44.0	6	5.00
B90113/64	13/64	5.16	87.0	44.0	6	5.16
B9015.5	—	5.50	93.0	47.0	6	5.50

Produit	DC	DC	OAL	LCF	NOF	DCON MS
	(inch)	(mm)	(mm)	(mm)		(mm)
B9017/32	7/32	5.56	93.0	47.0	6	5.56
B90115/64	15/64	5.95	93.0	47.0	6	5.95
B9016.0	—	6.00	93.0	47.0	6	6.00
B9011/4	1/4	6.35	100.0	50.0	6	6.35
B9017.0	—	7.00	107.0	54.0	6	7.00
B9019/32	9/32	7.14	107.0	54.0	6	7.14
B9015/16	5/16	7.94	115.0	58.0	6	7.94
B9018.0	—	8.00	115.0	58.0	6	8.00
B9019.0	—	9.00	124.0	62.0	6	9.00
B9013/8	3/8	9.52	133.0	66.0	6	9.52
B90110.0	—	10.00	133.0	66.0	6	10.00
B90111.0	—	11.00	142.0	71.0	6	11.00
B9017/16	7/16	11.11	142.0	71.0	6	11.11
B90112.0	—	12.00	152.0	76.0	6	12.00
B9011/2	1/2	12.70	152.0	76.0	6	12.70



B301



Alésoir à main conique en HSS à queue cylindrique, conicité 1:48, finition brillante et ST

Alésoir conçu pour la finition des trous coniques acceptant des goupilles coniques impériales standard de rapport 1 à 48. Avec un petit diamètre réduit, l'outil se positionne et se centre facilement dans le trou pré-percé pour améliorer la précision et les performances. Convient pour l'alésage dans de nombreux matériaux.

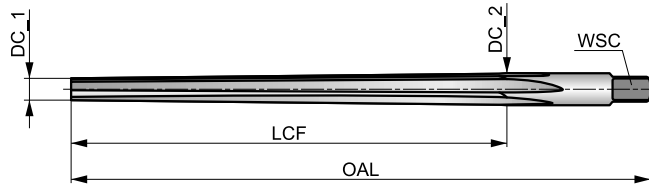

HSS	Bright ST	BS 328
R		A
1:48		

Adéquation du groupe de matériaux de la pièce, valeurs de départ pour la vitesse de coupe (m/min) et code Alpha d'avance. Les tableaux d'avances par tour se trouvent à partir de la page 251.

P1.1	P1.2	P1.3	P2.1	P2.2	P2.3	P3.1	P3.2	P3.3	P4.1	P4.2	P4.3	M1.1	M1.2
■	■	■	■	■	■	■	■	■	■	■	■	■	■
M2.1	K1.1	K1.2	K1.3	K2.1	K2.2	K2.3	K3.1	K3.2	N1.1	N1.2	N1.3	N2.1	N2.2
■	■	■	■	■	■	■	■	■	■	■	■	■	■
N2.3	N3.1	N3.2	N3.3	N4.1	N4.2								
■	■	■	■	■	■								

DC <= 1/4 limite de tolérance +0.0030; DC >= 9/32 limite de tolérance +0.0050.

Produit	nom d	DC_1	DC_2	OAL	LCF	NOF	WSC	DCON MS
		(mm)	(mm)					
B3011/16	1/16	1.10	1.63	51.0	25.0	4	1.20	1.63
B3015/64	5/64	1.50	2.03	51.0	25.0	4	1.60	2.03
B3013/32	3/32	1.75	2.41	57.0	32.0	4	2.00	2.41
B3017/64	7/64	2.03	2.82	64.0	38.0	4	2.20	2.82
B3011/8	1/8	2.30	3.23	70.0	44.0	4	2.50	3.23
B3019/64	9/64	2.64	3.63	73.0	48.0	4	2.80	3.63
B3015/32	5/32	2.95	4.01	76.0	51.0	4	3.10	4.01
B30111/64	11/64	3.23	4.42	89.0	57.0	4	3.60	4.42
B3013/16	3/16	3.50	4.95	102.0	70.0	4	4.00	4.95
B3017/32	7/32	4.13	5.59	102.0	70.0	6	4.50	5.59
B3011/4	1/4	4.64	6.43	117.0	86.0	6	5.00	6.43
B3019/32	9/32	5.23	7.42	143.0	105.0	6	5.60	7.42
B3015/16	5/16	5.84	8.03	143.0	105.0	6	6.30	8.03
B30111/32	11/32	6.43	8.81	152.0	114.0	6	7.10	8.81
B3013/8	3/8	7.03	9.68	165.0	127.0	6	8.00	9.68
B30113/32	13/32	7.42	10.46	191.0	146.0	6	8.00	10.46
B3017/16	7/16	8.21	11.25	191.0	146.0	6	9.00	11.25
B3011/2	1/2	9.41	12.85	210.0	165.0	6	10.00	12.85



B903



Alésoir à main conique en HSS à queue cylindrique, conicité 1:50, finition brillante et ST

Alésoir conçu pour la finition des trous coniques acceptant des goupilles coniques métriques standard de rapport 1 à 50. Le diamètre de la petite extrémité est réduit pour faciliter le positionnement et le centrage de l'alésoir dans le trou. Convient pour l'alésage dans de nombreux matériaux.

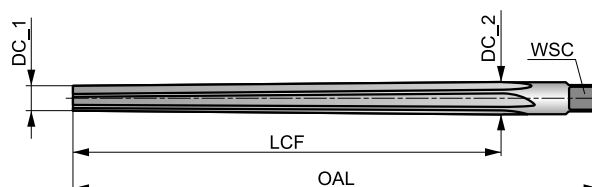

HSS	Bright ST	DIN 9
R		A
1:50		

Adéquation du groupe de matériaux de la pièce, valeurs de départ pour la vitesse de coupe (m/min) et code Alpha d'avance. Les tableaux d'avances par tour se trouvent à partir de la page 251.

P1.1	P1.2	P1.3	P2.1	P2.2	P2.3	P3.1	P3.2	P3.3	P4.1	P4.2	P4.3	M1.1	M1.2
■	■	■	■	■	■	■	■	■	■	■	■	■	■
M2.1	K1.1	K1.2	K1.3	K2.1	K2.2	K2.3	K3.1	K3.2	N1.1	N1.2	N1.3	N2.1	N2.2
■	■	■	■	■	■	■	■	■	■	■	■	■	■
N2.3	N3.1	N3.2	N3.3	N4.1	N4.2								
■	■	■	■	■	■								

DCON MS tolérance h11; DC ≤ 5mm limite de tolérance +0.0750; DC > 5mm limite de tolérance +0.1250.

Produit	nom d	DC_1	DC_2	OAL	LCF	NOF	WSC	DCON MS
		(mm)	(mm)					
B9031.5	1.5	1.40	2.14	57.0	37.0	4	1.80	2.14
B9032.0	2.0	1.90	2.86	68.0	48.0	4	2.24	2.86
B9032.5	2.5	2.40	3.36	68.0	48.0	4	2.80	3.36
B9033.0	3.0	2.90	4.06	80.0	58.0	4	3.15	4.00
B9034.0	4.0	3.90	5.26	93.0	68.0	4	4.00	5.00
B9035.0	5.0	4.90	6.36	100.0	73.0	4	5.00	6.30
B9036.0	6.0	5.90	8.00	135.0	105.0	6	6.30	7.90
B9038.0	8.0	7.90	10.80	180.0	145.0	6	8.00	10.50
B90310.0	10.0	9.90	13.40	215.0	175.0	6	10.00	13.30
B90312.0	12.0	11.80	16.00	255.0	210.0	8	11.20	16.00
B90313.0	13.0	12.86	16.74	255.0	210.0	8	12.50	16.74
B90314.0	14.0	13.86	17.74	255.0	210.0	8	12.50	17.74
B90316.0	16.0	15.80	20.40	280.0	230.0	8	14.00	20.40
B90320.0	20.0	19.80	24.80	310.0	250.0	8	18.00	24.80



B952



Alésoir à main en HSS pour goujille conique, à queue cylindrique, conicité 1:50, finition brillante

Alésoir avec une hélice à gauche et une coupe à droite, permet d'obtenir un alésage en douceur pour une tolérance de trou plus précise et une meilleure finition. Le diamètre en bout de cet alésoir a été réduit, ce qui facilite le positionnement et le centrage de l'outil dans le trou. Convient pour l'alésage dans de nombreux matériaux.

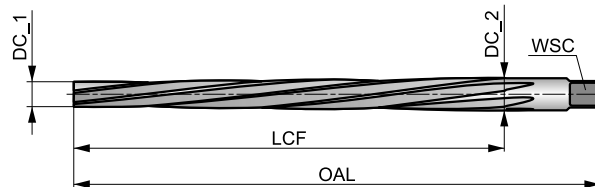

HSS	Bright	DIN 9
R		B
1:50		

Adéquation du groupe de matériaux de la pièce, valeurs de départ pour la vitesse de coupe (m/min) et code Alpha d'avance. Les tableaux d'avances par tour se trouvent à partir de la page 251.

P1.1	P1.2	P1.3	P2.1	P2.2	P2.3	P3.1	P3.2	P3.3	P4.1	P4.2	P4.3	M1.1	M1.2
■	■	■	■	■	■	■	■	■	■	■	■	■	■
M2.1	K1.1	K1.2	K1.3	K2.1	K2.2	K2.3	K3.1	K3.2	N1.1	N1.2	N1.3	N2.1	N2.2
■	■	■	■	■	■	■	■	■	■	■	■	■	■
N2.3	N3.1	N3.2	N3.3	N4.1	N4.2								
■	■	■	■	■	■								

DCON MS tolérance h11; DC <= 2.5mm. Goujure droite, forme A.

Produit	nom d	DC_1	DC_2	OAL	LCF	NOF	WSC	DCON MS
		(mm)	(mm)					
B9521.2	1.2	1.10	1.74	50.0	32.0	3	2.40	3.15
B9521.5	1.5	1.40	2.14	57.0	37.0	3	2.40	3.15
B9522.0	2.0	1.90	2.86	68.0	48.0	3	2.40	3.15
B9522.5	2.5	2.40	3.36	68.0	48.0	4	2.40	3.15
B9523.0	3.0	2.90	4.06	80.0	58.0	5	3.00	4.00
B9523.5	3.5	3.40	4.66	87.0	63.0	5	3.40	4.50
B9524.0	4.0	3.90	5.26	93.0	68.0	5	3.80	5.00
B9524.5	4.5	4.40	5.80	95.0	70.0	5	4.30	5.60
B9525.0	5.0	4.90	6.36	100.0	73.0	5	4.90	6.30
B9525.5	5.5	5.40	7.20	118.0	90.0	6	5.50	7.10
B9526.0	6.0	5.90	8.00	135.0	105.0	6	6.20	8.00
B9526.5	6.5	6.40	8.60	140.0	110.0	6	6.20	8.00
B9527.0	7.0	6.90	9.40	160.0	125.0	6	7.00	9.00
B9528.0	8.0	7.90	10.80	180.0	145.0	6	8.00	10.00
B9529.0	9.0	8.90	12.10	195.0	160.0	6	9.00	11.20
B95210.0	10.0	9.90	13.40	215.0	175.0	6	10.00	12.50
B95212.0	12.0	11.80	16.00	255.0	210.0	8	11.00	14.00
B95213.0	13.0	12.80	17.00	255.0	210.0	8	12.00	16.00
B95214.0	14.0	13.80	18.00	255.0	210.0	8	12.00	16.00
B95216.0	16.0	15.80	20.40	280.0	230.0	8	14.50	18.00
B95220.0	20.0	19.80	24.80	310.0	250.0	8	18.00	22.40
B95225.0	25.0	24.70	30.70	370.0	300.0	10	22.00	28.00
B95230.0	30.0	29.70	36.10	400.0	320.0	10	24.00	31.50
B95240.0	40.0	39.70	46.50	430.0	340.0	12	32.00	40.00
B95250.0	50.0	49.70	56.90	460.0	360.0	12	39.00	50.00



B122



Alésoir à main en HSS à queue réduite, finition traitée à la vapeur et au bronze

Alésoir conçu pour réaligner les trous dans les tôles ou pièces en acier à paroi mince avant de les boulonner ou de les riveter. Il est conçu pour être utilisé à la main. Le petit diamètre du pilote facilite le repérage et l'alignement de l'outil dans les trous pré-perçés. Convient à de nombreux matériaux.

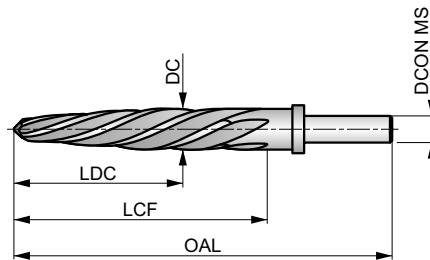

HSS	ST Bronze	ANSI
R		

Adéquation du groupe de matériaux de la pièce, valeurs de départ pour la vitesse de coupe (m/min) et code Alpha d'avance. Les tableaux d'avances par tour se trouvent à partir de la page 251.

P1.1 ■ 15 C	P1.2 ■ 16 C	P1.3 ■ 17 C	P2.1 ■ 13 C	P2.2 ■ 11 C	P3.1 ■ 7 B	M1.1 ■ 11 C	M1.2 ■ 10 B	M2.1 ■ 9 B	N1.1 ■ 23 F	N1.2 ■ 17 F	N2.1 ■ 23 E	N2.2 ■ 21 E	N3.1 ■ 34 D
N3.2 ■ 20 E	N4.1 ■ 22 B	N4.2 ■ 21 B											

Produit	DC	DC	OAL	DC	LCF	NOF	DCONMS
	(inch)	(inch)	(inch)		(inch)		(inch)
B1223/8	3/8	0.3750	4.5/8		2.1/2	4	3/8
B1221/2	1/2	0.5000	5.7/8		3.3/4	5	1/2
B1229/16	9/16	0.5625	5.7/8		3.3/4	5	1/2
B1225/8	5/8	0.6250	6.3/8		4.1/4	5	1/2
B12211/16	11/16	0.6875	6.3/8		4.1/4	5	1/2
B1223/4	3/4	0.7500	6.7/8		4.1/2	5	1/2
B12213/16	13/16	0.8125	6.7/8		4.1/2	5	1/2
B1227/8	7/8	0.8750	6.7/8		4.1/2	5	1/2
B12215/16	15/16	0.9375	6.7/8		4.1/2	5	1/2
B1221	1"	1.0000	6.7/8		4.1/2	5	1/2
B1221.1/16	1.1/16	1.0625	6.7/8		4.1/2	5	1/2



B953



Alésoir à main en HSS-E pour goupille conique, à queue cylindrique, conicité 1:50, finition brillante

Alésoir avec une spirale élevée, une hélice à gauche et une coupe à droite. Le cône de l'alésoir est conçu pour finir les trous coniques afin de recevoir des goupilles coniques métriques standard de rapport 1 à 50, tandis que l'entrée conique a un diamètre réduit pour améliorer les performances. Convient pour l'alésage dans de nombreux matériaux.

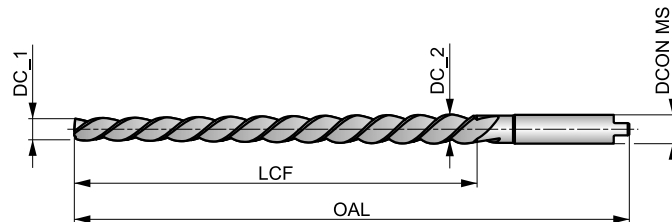

HSS-E	Bright	DIN 2179
R		1:50

Adéquation du groupe de matériaux de la pièce, valeurs de départ pour la vitesse de coupe (m/min) et code Alpha d'avance. Les tableaux d'avances par tour se trouvent à partir de la page 251.

P1.1 ■ 10 B	P1.2 ■ 12 B	P1.3 ■ 13 B	P2.1 ■ 9 B	P2.2 ■ 8 B	P2.3 ▣ 6 A	P3.1 ■ 7 A	P3.2 ▣ 6 A	P3.3 ▣ 3 A	P4.1 ■ 4 A	P4.2 ▣ 3 A	P4.3 ▣ 2 A	M1.1 ▣ 11 C	M1.2 ▣ 10 B
M2.1 ▣ 9 B	M2.2 ▣ 8 B	K1.1 ■ 10 C	K1.2 ■ 6 B	K1.3 ▣ 4 B	K2.1 ■ 8 A	K2.2 ■ 6 A	K2.3 ▣ 4 A	K3.1 ■ 7 A	K3.2 ▣ 4 A	N1.1 ▣ 14 D	N1.2 ■ 12 D	N1.3 ■ 9 D	N2.1 ■ 16 C
N2.2 ■ 14 C	N2.3 ▣ 10 C	N3.1 ■ 22 B	N3.2 ■ 14 C	N3.3 ▣ 6 B	N4.1 ▣ 22 B								

DCON MS tolérance h9.

Produit	nom d	DC_1	DC_2	OAL	LCF	NOF	DCON MS
		(mm)	(mm)	(mm)	(mm)		
B9531.0	1.0	0.80	1.46	60.0	33.0	2	1.40
B9531.5	1.5	1.40	2.14	70.0	37.0	2	2.10
B9532.0	2.0	1.90	2.86	86.0	48.0	3	3.15
B9532.5	2.5	2.40	3.36	86.0	48.0	3	3.15
B9533.0	3.0	2.90	4.06	100.0	58.0	3	4.00
B9534.0	4.0	3.90	5.26	112.0	68.0	3	5.00
B9535.0	5.0	4.90	6.36	122.0	73.0	3	6.30
B9536.0	6.0	5.90	8.00	160.0	105.0	3	8.00
B9536.5	6.5	6.40	8.78	188.0	119.0	3	8.50
B9538.0	8.0	7.90	10.80	207.0	145.0	3	10.00
B95310.0	10.0	9.90	13.40	245.0	175.0	3	12.50
B95312.0	12.0	11.80	16.00	290.0	210.0	3	16.00



B180



Alésoir machine en HSS-E à queue cylindrique pour précision H7, finition brillante

Alésoir haute performance pour les machines CNC à monter dans des porte-outils ou mandrins de haute précision. L'hélice à gauche rectifiée avec précision et l'action de coupe à droite assurent un alésage en douceur et améliorent la finition de surface et la taille des trous. Convient pour l'alésage dans de nombreux matériaux.

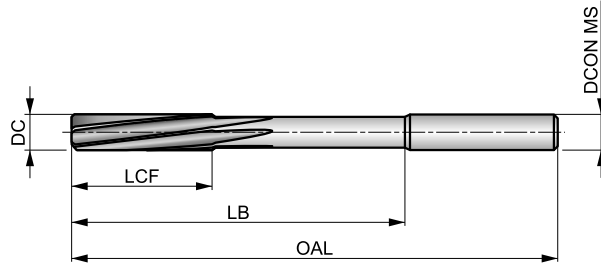

HSS-E	Bright	DIN 212
R	DIN 6535HA	B
H7		

Adéquation du groupe de matériaux de la pièce, valeurs de départ pour la vitesse de coupe (m/min) et code Alpha d'avance. Les tableaux d'avances par tour se trouvent à partir de la page 251.

P1.1 ■ 21 C	P1.2 ■ 24 C	P1.3 ■ 25 C	P2.1 ■ 18 C	P2.2 ■ 16 C	P2.3 ■ 14 B	P3.1 ■ 13 B	P3.2 ■ 11 B	P3.3 ■ 9 B	P4.1 ■ 8 B	P4.2 ■ 7 B	P4.3 ■ 5 A	M1.1 ■ 11 C	M1.2 ■ 10 B
M2.1 ■ 9 B	K1.1 ■ 16 E	K1.2 ■ 12 D	K1.3 ■ 9 D	K2.1 ■ 16 C	K2.2 ■ 13 C	K2.3 ■ 10 C	K3.1 ■ 14 C	K3.2 ■ 11 C	N1.1 ■ 24 F	N1.2 ■ 18 F	N1.3 ■ 11 F	N2.1 ■ 27 E	N2.2 ■ 24 E
N2.3 ■ 16 E	N3.1 ■ 47 D	N3.2 ■ 28 E	N3.3 ■ 14 D	N4.1 ■ 30 B									

DCON MS tolérance h6.

Produit	DC (mm)	OAL (mm)	LCF (mm)	LB (mm)	NOF	DCON MS (mm)
B1801.5	1.50	40.0	8.0	18.00	3	2.00
B1801.6	1.60	43.0	9.0	20.00	3	2.00
B1801.7	1.70	43.0	9.0	20.00	3	2.00
B1801.8	1.80	46.0	10.0	22.00	4	2.00
B1801.9	1.90	46.0	10.0	22.00	4	2.00
B1802.0	2.00	49.0	11.0	24.00	4	2.00
B1802.1	2.10	49.0	11.0	24.00	4	2.00
B1802.2	2.20	53.0	12.0	26.00	4	3.00
B1802.3	2.30	53.0	12.0	26.00	4	3.00
B1802.4	2.40	57.0	14.0	28.00	4	3.00
B1802.5	2.50	57.0	14.0	28.00	4	3.00
B1802.6	2.60	57.0	14.0	28.00	4	3.00
B1802.7	2.70	61.0	15.0	32.00	6	3.00
B1802.8	2.80	61.0	15.0	32.00	6	3.00
B1802.9	2.90	61.0	15.0	32.00	6	3.00
B1803.0	3.00	61.0	15.0	32.00	6	3.00
B1803.1	3.10	65.0	16.0	35.00	6	4.00
B1803.2	3.20	65.0	16.0	35.00	6	4.00
B1803.3	3.30	65.0	16.0	35.00	6	4.00
B1803.4	3.40	70.0	18.0	40.00	6	4.00
B1803.5	3.50	70.0	18.0	40.00	6	4.00
B1803.6	3.60	70.0	18.0	40.00	6	4.00
B1803.7	3.70	70.0	18.0	40.00	6	4.00
B1803.8	3.80	75.0	19.0	43.00	6	4.00
B1803.9	3.90	75.0	19.0	43.00	6	4.00
B1804.0	4.00	75.0	19.0	43.00	6	4.00
B1804.1	4.10	75.0	19.0	43.00	6	4.00

Produit	DC (mm)	OAL (mm)	LCF (mm)	LB (mm)	NOF	DCON MS (mm)
B1804.2	4.20	75.0	19.0	43.00	6	4.00
B1804.3	4.30	80.0	21.0	47.00	6	5.00
B1804.4	4.40	80.0	21.0	47.00	6	5.00
B1804.5	4.50	80.0	21.0	47.00	6	5.00
B1804.6	4.60	80.0	21.0	47.00	6	5.00
B1804.7	4.70	80.0	21.0	47.00	6	5.00
B1804.8	4.80	86.0	23.0	52.00	6	5.00
B1804.9	4.90	86.0	23.0	52.00	6	5.00
B1805.0	5.00	86.0	23.0	52.00	6	5.00
B1805.1	5.10	86.0	23.0	52.00	6	5.00
B1805.2	5.20	86.0	23.0	52.00	6	5.00
B1805.3	5.30	86.0	23.0	52.00	6	5.00
B1805.4	5.40	93.0	26.0	57.00	6	6.00
B1805.5	5.50	93.0	26.0	57.00	6	6.00
B1805.6	5.60	93.0	26.0	57.00	6	6.00
B1805.7	5.70	93.0	26.0	57.00	6	6.00
B1805.8	5.80	93.0	26.0	57.00	6	6.00
B1805.9	5.90	93.0	26.0	57.00	6	6.00
B1806.0	6.00	93.0	26.0	57.00	6	6.00
B1806.1	6.10	101.0	28.0	63.00	6	6.00
B1806.2	6.20	101.0	28.0	63.00	6	6.00
B1806.3	6.30	101.0	28.0	63.00	6	6.00
B1806.4	6.40	101.0	28.0	63.00	6	6.00
B1806.5	6.50	101.0	28.0	63.00	6	6.00
B1806.6	6.60	101.0	28.0	63.00	6	6.00
B1806.7	6.70	101.0	28.0	63.00	6	6.00
B1806.8	6.80	109.0	31.0	69.00	6	8.00



Produit	DC	OAL	LCF	LB	NOF	DCON MS
	(mm)	(mm)	(mm)	(mm)		(mm)
B1806.9	6.90	109.0	31.0	69.00	6	8.00
B1807.0	7.00	109.0	31.0	69.00	6	8.00
B1807.1	7.10	109.0	31.0	69.00	6	8.00
B1807.2	7.20	109.0	31.0	69.00	6	8.00
B1807.3	7.30	109.0	31.0	69.00	6	8.00
B1807.4	7.40	109.0	31.0	69.00	6	8.00
B1807.5	7.50	109.0	31.0	69.00	6	8.00
B1807.6	7.60	117.0	33.0	75.00	6	8.00
B1807.7	7.70	117.0	33.0	75.00	6	8.00
B1807.8	7.80	117.0	33.0	75.00	6	8.00
B1807.9	7.90	117.0	33.0	75.00	6	8.00
B1808.0	8.00	117.0	33.0	75.00	6	8.00
B1808.1	8.10	117.0	33.0	75.00	6	8.00
B1808.2	8.20	117.0	33.0	75.00	6	8.00
B1808.3	8.30	117.0	33.0	75.00	6	8.00
B1808.4	8.40	117.0	33.0	75.00	6	8.00
B1808.5	8.50	117.0	33.0	75.00	6	8.00
B1808.6	8.60	125.0	36.0	81.00	6	10.00
B1808.7	8.70	125.0	36.0	81.00	6	10.00
B1808.8	8.80	125.0	36.0	81.00	6	10.00
B1808.9	8.90	125.0	36.0	81.00	6	10.00

Produit	DC	OAL	LCF	LB	NOF	DCON MS
	(mm)	(mm)	(mm)	(mm)		(mm)
B1809.0	9.00	125.0	36.0	81.00	6	10.00
B1809.1	9.10	125.0	36.0	81.00	6	10.00
B1809.2	9.20	125.0	36.0	81.00	6	10.00
B1809.3	9.30	125.0	36.0	81.00	6	10.00
B1809.4	9.40	125.0	36.0	81.00	6	10.00
B1809.5	9.50	125.0	36.0	81.00	6	10.00
B1809.6	9.60	133.0	38.0	87.00	6	10.00
B1809.7	9.70	133.0	38.0	87.00	6	10.00
B1809.8	9.80	133.0	38.0	87.00	6	10.00
B1809.9	9.90	133.0	38.0	87.00	6	10.00
B18010.0	10.00	133.0	38.0	87.00	6	10.00
B18011.0	11.00	142.0	41.0	96.00	6	10.00
B18012.0	12.00	151.0	44.0	105.00	6	10.00
B18013.0	13.00	151.0	44.0	105.00	6	10.00
B18014.0	14.00	160.0	47.0	110.00	8	14.00
B18015.0	15.00	162.0	50.0	112.00	8	14.00
B18016.0	16.00	170.0	52.0	120.00	8	14.00
B18017.0	17.00	175.0	54.0	123.00	8	14.00
B18018.0	18.00	182.0	56.0	130.00	8	14.00
B18019.0	19.00	189.0	58.0	131.00	8	16.00
B18020.0	20.00	195.0	60.0	137.00	8	16.00



B170



Alésoir machine en HSS-E à queue cylindrique - Incréments de 0,01 mm, finition brillante

Alésoir disponible dans différentes tailles d'incrément au centième vous permettent de produire des tailles de trous précises et des tolérances de trous supplémentaires. Avec une hélice à gauche et une action de coupe à droite, la géométrie rectifiée avec précision permet un alésage en douceur et améliore la taille des trous et la finition de surface. Convient pour l'alésage dans de nombreux matériaux.

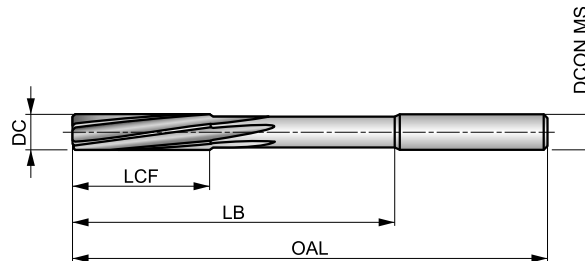

HSS-E	Bright	DIN 212
R		B
$\phi_{.95-5.5}$ $+0.004$ $\phi_{5.51-12}$ $+0.005$		

Adéquation du groupe de matériaux de la pièce, valeurs de départ pour la vitesse de coupe (m/min) et code Alpha d'avance. Les tableaux d'avances par tour se trouvent à partir de la page 251.

P1.1 ■ 21 C	P1.2 ■ 24 C	P1.3 ■ 25 C	P2.1 ■ 18 C	P2.2 ■ 16 C	P2.3 ■ 14 B	P3.1 ■ 13 B	P3.2 ■ 11 B	P3.3 ■ 9 B	P4.1 ■ 8 B	P4.2 ■ 7 B	P4.3 ■ 5 A	M1.1 ■ 11 C	M1.2 ■ 10 B
M2.1 ■ 9 B	K1.1 ■ 16 E	K1.2 ■ 12 D	K1.3 ■ 9 D	K2.1 ■ 16 C	K2.2 ■ 13 C	K2.3 ■ 10 C	K3.1 ■ 14 C	K3.2 ■ 11 C	N1.1 ■ 24 D	N1.2 ■ 18 F	N1.3 ■ 11 F	N2.1 ■ 27 E	N2.2 ■ 24 E
N2.3 ■ 16 E	N3.1 ■ 47 D	N3.2 ■ 28 E	N3.3 ■ 14 D	N4.1 ■ 30 B									

DCON MS tolérance h9.

Produit	DC	OAL	LCF	LB	NOF	DCON MS
	(mm)	(mm)	(mm)	(mm)		(mm)
B170.98	0.98	34.0	5.5	15.00	3	1.00
B170.99	0.99	34.0	5.5	15.00	3	1.00
B1701.0	1.00	34.0	5.5	15.00	3	1.00
B1701.01	1.01	34.0	5.5	15.00	3	1.00
B1701.02	1.02	34.0	5.5	15.00	3	1.00
B1701.03	1.03	34.0	5.5	15.00	3	1.00
B1701.04	1.04	34.0	5.5	15.00	3	1.00
B1701.05	1.05	34.0	5.5	15.00	3	1.00
B1701.49	1.49	40.0	8.0	18.00	3	1.50
B1701.5	1.50	40.0	8.0	18.00	3	1.50
B1701.51	1.51	43.0	9.0	20.00	3	1.60
B1701.52	1.52	43.0	9.0	20.00	3	1.60
B1701.98	1.98	49.0	11.0	24.00	4	2.00
B1701.99	1.99	49.0	11.0	24.00	4	2.00
B1702.0	2.00	49.0	11.0	24.00	4	2.00
B1702.01	2.01	49.0	11.0	24.00	4	2.00
B1702.02	2.02	49.0	11.0	24.00	4	2.00
B1702.03	2.03	49.0	11.0	24.00	4	2.00
B1702.04	2.04	49.0	11.0	24.00	4	2.00
B1702.05	2.05	49.0	11.0	24.00	4	2.00
B1702.49	2.49	57.0	14.0	28.00	4	2.50
B1702.5	2.50	57.0	14.0	28.00	4	2.50
B1702.51	2.51	57.0	14.0	28.00	4	2.50
B1702.52	2.52	57.0	14.0	28.00	4	2.50
B1702.98	2.98	61.0	15.0	32.00	6	3.00
B1702.99	2.99	61.0	15.0	32.00	6	3.00
B1703.0	3.00	61.0	15.0	32.00	6	3.00

Produit	DC	OAL	LCF	LB	NOF	DCON MS
	(mm)	(mm)	(mm)	(mm)		(mm)
B1703.01	3.01	65.0	16.0	35.00	6	3.20
B1703.02	3.02	65.0	16.0	35.00	6	3.20
B1703.03	3.03	65.0	16.0	35.00	6	3.20
B1703.04	3.04	65.0	16.0	35.00	6	3.20
B1703.05	3.05	65.0	16.0	35.00	6	3.20
B1703.49	3.49	70.0	18.0	40.00	6	3.50
B1703.5	3.50	70.0	18.0	40.00	6	3.50
B1703.51	3.51	70.0	18.0	40.00	6	3.50
B1703.52	3.52	70.0	18.0	40.00	6	3.50
B1703.98	3.98	75.0	19.0	43.00	6	4.00
B1703.99	3.99	75.0	19.0	43.00	6	4.00
B1704.0	4.00	75.0	19.0	43.00	6	4.00
B1704.01	4.01	75.0	19.0	43.00	6	4.00
B1704.02	4.02	75.0	19.0	43.00	6	4.00
B1704.03	4.03	75.0	19.0	43.00	6	4.00
B1704.04	4.04	75.0	19.0	43.00	6	4.00
B1704.05	4.05	75.0	19.0	43.00	6	4.00
B1704.49	4.49	80.0	21.0	47.00	6	4.50
B1704.5	4.50	80.0	21.0	47.00	6	4.50
B1704.51	4.51	80.0	21.0	47.00	6	4.50
B1704.52	4.52	80.0	21.0	47.00	6	4.50
B1704.98	4.98	86.0	23.0	52.00	6	5.00
B1704.99	4.99	86.0	23.0	52.00	6	5.00
B1705.0	5.00	86.0	23.0	52.00	6	5.00
B1705.01	5.01	86.0	23.0	52.00	6	5.00
B1705.02	5.02	86.0	23.0	52.00	6	5.00
B1705.03	5.03	86.0	23.0	52.00	6	5.00



Produit	DC	OAL	LCF	LB	NOF	DCON MS
	(mm)	(mm)	(mm)	(mm)		(mm)
B1705.04	5.04	86.0	23.0	52.00	6	5.00
B1705.05	5.05	86.0	23.0	52.00	6	5.00
B1705.49	5.49	93.0	26.0	57.00	6	5.60
B1705.5	5.50	93.0	26.0	57.00	6	5.60
B1705.51	5.51	93.0	26.0	57.00	6	5.60
B1705.52	5.52	93.0	26.0	57.00	6	5.60
B1705.98	5.98	93.0	26.0	57.00	6	5.60
B1705.99	5.99	93.0	26.0	57.00	6	5.60
B1706.0	6.00	93.0	26.0	57.00	6	5.60
B1706.01	6.01	101.0	28.0	63.00	6	6.30
B1706.02	6.02	101.0	28.0	63.00	6	6.30
B1706.03	6.03	101.0	28.0	63.00	6	6.30
B1706.04	6.04	101.0	28.0	63.00	6	6.30
B1706.05	6.05	101.0	28.0	63.00	6	6.30
B1706.49	6.49	101.0	28.0	63.00	6	6.30
B1706.5	6.50	101.0	28.0	63.00	6	6.30
B1706.51	6.51	101.0	28.0	63.00	6	6.30
B1706.52	6.52	101.0	28.0	63.00	6	6.30
B1706.98	6.98	109.0	31.0	69.00	6	7.10
B1706.99	6.99	109.0	31.0	69.00	6	7.10
B1707.0	7.00	109.0	31.0	69.00	6	7.10
B1707.01	7.01	109.0	31.0	69.00	6	7.10
B1707.02	7.02	109.0	31.0	69.00	6	7.10
B1707.03	7.03	109.0	31.0	69.00	6	7.10
B1707.04	7.04	109.0	31.0	69.00	6	7.10
B1707.05	7.05	109.0	31.0	69.00	6	7.10
B1707.49	7.49	109.0	31.0	69.00	6	7.10
B1707.5	7.50	109.0	31.0	69.00	6	7.10
B1707.51	7.51	117.0	33.0	75.00	6	8.00
B1707.52	7.52	117.0	33.0	75.00	6	8.00
B1707.98	7.98	117.0	33.0	75.00	6	8.00
B1707.99	7.99	117.0	33.0	75.00	6	8.00
B1708.0	8.00	117.0	33.0	75.00	6	8.00
B1708.01	8.01	117.0	33.0	75.00	6	8.00
B1708.02	8.02	117.0	33.0	75.00	6	8.00
B1708.03	8.03	117.0	33.0	75.00	6	8.00
B1708.04	8.04	117.0	33.0	75.00	6	8.00
B1708.05	8.05	117.0	33.0	75.00	6	8.00
B1708.49	8.49	117.0	33.0	75.00	6	8.00
B1708.5	8.50	117.0	33.0	75.00	6	8.00

Produit	DC	OAL	LCF	LB	NOF	DCON MS
	(mm)	(mm)	(mm)	(mm)		(mm)
B1708.51	8.51	125.0	36.0	81.00	6	9.00
B1708.52	8.52	125.0	36.0	81.00	6	9.00
B1708.98	8.98	125.0	36.0	81.00	6	9.00
B1708.99	8.99	125.0	36.0	81.00	6	9.00
B1709.0	9.00	125.0	36.0	81.00	6	9.00
B1709.01	9.01	125.0	36.0	81.00	6	9.00
B1709.02	9.02	125.0	36.0	81.00	6	9.00
B1709.03	9.03	125.0	36.0	81.00	6	9.00
B1709.04	9.04	125.0	36.0	81.00	6	9.00
B1709.05	9.05	125.0	36.0	81.00	6	9.00
B1709.49	9.49	125.0	36.0	81.00	6	9.00
B1709.5	9.50	125.0	36.0	81.00	6	9.00
B1709.51	9.51	133.0	38.0	87.00	6	10.00
B1709.52	9.52	133.0	38.0	87.00	6	10.00
B1709.98	9.98	133.0	38.0	87.00	6	10.00
B1709.99	9.99	133.0	38.0	87.00	6	10.00
B17010.0	10.00	133.0	38.0	87.00	6	10.00
B17010.01	10.01	133.0	38.0	87.00	6	10.00
B17010.02	10.02	133.0	38.0	87.00	6	10.00
B17010.03	10.03	133.0	38.0	87.00	6	10.00
B17010.04	10.04	133.0	38.0	87.00	6	10.00
B17010.05	10.05	133.0	38.0	87.00	6	10.00
B17010.49	10.49	133.0	38.0	87.00	6	10.00
B17010.51	10.51	133.0	38.0	87.00	6	10.00
B17010.52	10.52	133.0	38.0	87.00	6	10.00
B17010.98	10.98	142.0	41.0	96.00	6	10.00
B17010.99	10.99	142.0	41.0	96.00	6	10.00
B17011.0	11.00	142.0	41.0	96.00	6	10.00
B17011.01	11.01	142.0	41.0	96.00	6	10.00
B17011.02	11.02	142.0	41.0	96.00	6	10.00
B17011.03	11.03	142.0	41.0	96.00	6	10.00
B17011.04	11.04	142.0	41.0	96.00	6	10.00
B17011.05	11.05	142.0	41.0	96.00	6	10.00
B17011.49	11.49	142.0	41.0	96.00	6	10.00
B17011.5	11.50	142.0	41.0	96.00	6	10.00
B17011.51	11.51	142.0	41.0	96.00	6	10.00
B17011.52	11.52	142.0	41.0	96.00	6	10.00
B17011.98	11.98	151.0	44.0	105.00	6	10.00
B17011.99	11.99	151.0	44.0	105.00	6	10.00
B17012.0	12.00	151.0	44.0	105.00	6	10.00



B157



Alésoir machine en HSS-E à hélice rapide et à queue cylindrique, précision H7, finition brillante

Alésoir pourvu d'un grand angle d'hélice à gauche et d'une action de coupe à droite offrant de grandes performances, en particulier lors de l'usinage de matériaux non ferreux, tels que l'aluminium. Elle convient également pour l'alésage d'autres matériaux. L'entrée conique facilite le repérage et le centrage, ce qui garantit de meilleures performances et une meilleure qualité de trou.

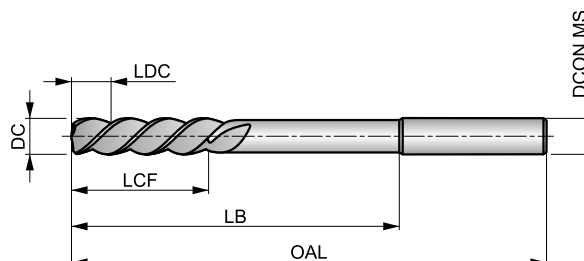

HSS-E	Bright	DIN 212
R		E
H7		

Adéquation du groupe de matériaux de la pièce, valeurs de départ pour la vitesse de coupe (m/min) et code Alpha d'avance. Les tableaux d'avances par tour se trouvent à partir de la page 251.

P1.1 ■ 21 C	P1.2 ■ 24 C	P1.3 ■ 25 C	P2.1 ■ 18 C	P2.2 ■ 16 C	P3.1 ■ 13 B	P3.2 ■ 11 B	M1.1 ■ 11 C	M1.2 ■ 10 C	M2.1 ■ 9 C	M2.2 ■ 8 B	M2.3 ■ 7 B	N1.1 ■ 28 F	N1.2 ■ 21 F
N1.3 ■ 14 F	N2.1 ■ 31 E	N2.2 ■ 28 E	N2.3 ■ 20 E										

DCON MS tolérance h9.

Produit	DC (mm)	OAL (mm)	LCF (mm)	LDC (mm)	LB (mm)	NOF	DCON MS (mm)
B1572.0	2.00	49.0	11.0	3.50	24.00	3	2.00
B1573.0	3.00	61.0	15.0	4.00	32.00	3	3.00
B1574.0	4.00	75.0	19.0	4.00	43.00	3	4.00
B1575.0	5.00	86.0	23.0	4.50	52.00	3	5.00
B1576.0	6.00	93.0	26.0	6.00	57.00	3	5.60
B1577.0	7.00	109.0	31.0	7.00	69.00	3	7.10
B1578.0	8.00	117.0	33.0	9.00	75.00	3	8.00
B1579.0	9.00	125.0	36.0	9.50	81.00	3	9.00
B15710.0	10.00	133.0	38.0	10.00	87.00	3	10.00
B15711.0	11.00	142.0	41.0	10.50	96.00	3	10.00
B15712.0	12.00	151.0	44.0	11.00	105.00	3	10.00
B15713.0	13.00	151.0	44.0	11.50	105.00	3	10.00
B15714.0	14.00	160.0	47.0	12.00	110.00	3	12.50
B15715.0	15.00	162.0	50.0	12.50	112.00	3	12.50
B15716.0	16.00	170.0	52.0	13.00	120.00	3	12.50
B15717.0	17.00	175.0	54.0	13.50	123.00	3	14.00
B15718.0	18.00	182.0	56.0	14.00	130.00	3	14.00
B15719.0	19.00	189.0	58.0	14.50	131.00	3	16.00
B15720.0	20.00	195.0	60.0	15.00	137.00	3	16.00



B161



Alésoir machine en HSS-E à queue cône morse pour précision H7, finition brillante

Alésoir avec hélice à gauche rectifiée avec précision et action de coupe à droite assurant un alésage en douceur et améliorent l'état de surface et la taille des trous. Convient pour l'alésage dans de nombreux matériaux.

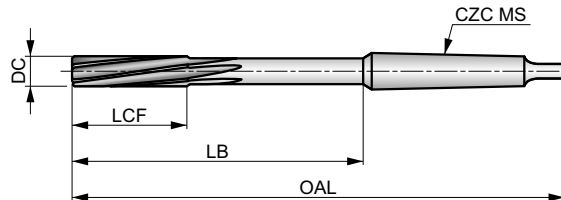

HSS-E	Bright	DIN 208
R		B
H7		

Adéquation du groupe de matériaux de la pièce, valeurs de départ pour la vitesse de coupe (m/min) et code Alpha d'avance. Les tableaux d'avances par tour se trouvent à partir de la page 251.

P1.1 ■ 21 C	P1.2 ■ 24 C	P1.3 ■ 25 C	P2.1 ■ 18 C	P2.2 ■ 16 C	P2.3 ■ 14 B	P3.1 ■ 13 B	P3.2 ■ 11 B	P3.3 ■ 9 B	P4.1 ■ 8 B	P4.2 ■ 7 B	P4.3 ■ 5 A	M1.1 ■ 11 C	M1.2 ■ 10 B
M2.1 ■ 9 B	K1.1 ■ 16 E	K1.2 ■ 12 D	K1.3 ■ 9 D	K2.1 ■ 16 C	K2.2 ■ 13 C	K2.3 ■ 10 C	K3.1 ■ 14 C	K3.2 ■ 11 C	N1.1 ■ 24 F	N1.2 ■ 18 F	N1.3 ■ 11 F	N2.1 ■ 27 E	N2.2 ■ 24 E
N2.3 ■ 16 E	N3.1 ■ 47 D	N3.2 ■ 28 E	N3.3 ■ 14 D	N4.1 ■ 30 B									

Produit	DC (mm)	OAL (mm)	LCF (mm)	LB (mm)	NOF	CZC MS
B1613.0	3.00	113.0	15.0	47.50	6	MK 1
B1614.0	4.00	124.0	19.0	58.50	6	MK 1
B1615.0	5.00	133.0	23.0	67.50	6	MK 1
B1616.0	6.00	138.0	26.0	72.50	6	MK 1
B1617.0	7.00	150.0	31.0	84.50	6	MK 1
B1618.0	8.00	156.0	33.0	90.50	6	MK 1
B1619.0	9.00	162.0	36.0	96.50	6	MK 1
B16110.0	10.00	168.0	38.0	102.50	6	MK 1
B16111.0	11.00	175.0	41.0	109.50	6	MK 1
B16112.0	12.00	182.0	44.0	116.50	6	MK 1
B16113.0	13.00	182.0	44.0	116.50	6	MK 1
B16114.0	14.00	189.0	47.0	123.50	8	MK 1
B16115.0	15.00	204.0	50.0	124.00	8	MK 2
B16116.0	16.00	210.0	52.0	130.00	8	MK 2
B16117.0	17.00	214.0	54.0	134.00	8	MK 2
B16118.0	18.00	219.0	56.0	139.00	8	MK 2
B16119.0	19.00	223.0	58.0	143.00	8	MK 2
B16120.0	20.00	228.0	60.0	148.00	8	MK 2
B16121.0	21.00	232.0	62.0	152.00	8	MK 2
B16122.0	22.00	237.0	64.0	157.00	8	MK 2
B16123.0	23.00	241.0	66.0	161.00	8	MK 2
B16124.0	24.00	268.0	68.0	169.00	8	MK 3

Produit	DC (mm)	OAL (mm)	LCF (mm)	LB (mm)	NOF	CZC MS
B16125.0	25.00	268.0	68.0	169.00	8	MK 3
B16126.0	26.00	273.0	70.0	174.00	8	MK 3
B16127.0	27.00	277.0	71.0	178.00	10	MK 3
B16128.0	28.00	277.0	71.0	178.00	10	MK 3
B16129.0	29.00	281.0	73.0	182.00	10	MK 3
B16130.0	30.00	281.0	73.0	182.00	10	MK 3
B16131.0	31.00	285.0	75.0	186.00	10	MK 3
B16132.0	32.00	317.0	77.0	193.00	10	MK 4
B16133.0	33.00	317.0	77.0	193.00	10	MK 4
B16134.0	34.00	321.0	78.0	197.00	10	MK 4
B16135.0	35.00	321.0	78.0	197.00	10	MK 4
B16136.0	36.00	325.0	79.0	201.00	10	MK 4
B16138.0	38.00	329.0	81.0	205.00	10	MK 4
B16140.0	40.00	329.0	81.0	205.00	10	MK 4
B16142.0	42.00	333.0	82.0	209.00	12	MK 4
B16144.0	44.00	336.0	83.0	212.00	12	MK 4
B16145.0	45.00	336.0	83.0	212.00	12	MK 4
B16146.0	46.00	340.0	84.0	216.00	12	MK 4
B16147.0	47.00	340.0	84.0	216.00	12	MK 4
B16148.0	48.00	344.0	86.0	220.00	12	MK 4
B16150.0	50.00	344.0	86.0	220.00	12	MK 4



B101



Alésoir machine en HSS-E à queue cône morse pour précision H7

Alésoir machine à queue cône morse conforme à la norme BS 328. L'hélice à gauche rectifiée avec précision et l'action de coupe à droite assurent un alésage en douceur et améliorent l'état de surface et la taille des trous. Convient pour l'alésage dans de nombreux matériaux.

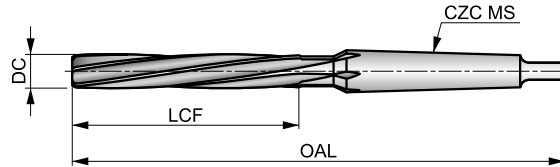

HSS-E	Bright ST	BS 328
R		B
H7		

Adéquation du groupe de matériaux de la pièce, valeurs de départ pour la vitesse de coupe (m/min) et code Alpha d'avance. Les tableaux d'avances par tour se trouvent à partir de la page 251.

P1.1 ■ 15 C	P1.2 ■ 16 C	P1.3 ■ 17 C	P2.1 ■ 13 C	P2.2 ■ 11 C	P2.3 ▣ 10 B	P3.1 ■ 7 B	P3.2 ■ 6 B	P3.3 ▣ 5 B	P4.1 ■ 4 B	P4.2 ▣ 4 B	P4.3 ▣ 3 A	M1.1 ▣ 7 B	M1.2 ▣ 6 A
K1.1 ■ 14 E	K1.2 ■ 10 D	K1.3 ▣ 8 D	K2.1 ■ 12 C	K2.2 ■ 10 C	K2.3 ▣ 8 C	K3.1 ■ 11 C	K3.2 ▣ 8 C	N1.1 ▣ 23 F	N1.2 ■ 17 F	N1.3 ■ 9 F	N2.1 ▣ 25 E	N2.2 ■ 18 E	N2.3 ■ 14 E
N3.1 ■ 34 D	N3.2 ■ 20 E	N3.3 ▣ 10 D	N4.1 ▣ 22 B										

Produit	DC	DC	OAL	LCF	NOF	CZC MS
	(inch)	(mm)	(mm)	(mm)		
B1013.0	—	3.00	112.0	33.0	4	MK 1
B1011/8	1/8	3.18	112.0	33.0	4	MK 1
B1013.5	—	3.50	115.0	35.0	6	MK 1
B1014.0	—	4.00	117.0	38.0	6	MK 1
B1014.5	—	4.50	120.0	41.0	6	MK 1
B1013/16	3/16	4.76	124.0	44.0	6	MK 1
B1015.0	—	5.00	124.0	44.0	6	MK 1
B1015.5	—	5.50	127.0	47.0	6	MK 1
B1016.0	—	6.00	127.0	47.0	6	MK 1
B1011/4	1/4	6.35	130.0	50.0	6	MK 1
B1016.5	—	6.50	130.0	50.0	6	MK 1
B1017.0	—	7.00	134.0	54.0	6	MK 1
B1015/16	5/16	7.94	138.0	58.0	6	MK 1
B1018.0	—	8.00	138.0	58.0	6	MK 1
B1018.5	—	8.50	138.0	58.0	6	MK 1
B1019.0	—	9.00	142.0	62.0	6	MK 1
B1019.5	—	9.50	142.0	62.0	6	MK 1
B1013/8	3/8	9.52	146.0	66.0	6	MK 1
B10110.0	—	10.00	146.0	66.0	6	MK 1
B10110.5	—	10.50	146.0	66.0	6	MK 1
B10111.0	—	11.00	151.0	71.0	6	MK 1
B1017/16	7/16	11.11	151.0	71.0	6	MK 1
B10112.0	—	12.00	156.0	76.0	6	MK 1
B10112.5	—	12.50	156.0	76.0	6	MK 1
B1011/2	1/2	12.70	156.0	76.0	6	MK 1
B10113.0	—	13.00	156.0	76.0	6	MK 1
B10113.5	—	13.50	161.0	81.0	6	MK 1
B10114.0	—	14.00	161.0	81.0	8	MK 1

Produit	DC	DC	OAL	LCF	NOF	CZC MS
	(inch)	(mm)	(mm)	(mm)		
B1019/16	9/16	14.29	181.0	81.0	8	MK 2
B10114.5	—	14.50	181.0	81.0	8	MK 2
B10115.0	—	15.00	181.0	81.0	8	MK 2
B10115.5	—	15.50	187.0	87.0	8	MK 2
B1015/8	5/8	15.88	187.0	87.0	8	MK 2
B10116.0	—	16.00	187.0	87.0	8	MK 2
B10116.5	—	16.50	187.0	87.0	8	MK 2
B10117.0	—	17.00	187.0	87.0	8	MK 2
B10118.0	—	18.00	193.0	93.0	8	MK 2
B10119.0	—	19.00	193.0	93.0	8	MK 2
B1013/4	3/4	19.05	200.0	100.0	8	MK 2
B10120.0	—	20.00	200.0	100.0	8	MK 2
B10113/16	13/16	20.64	200.0	100.0	8	MK 2
B10121.0	—	21.00	200.0	100.0	8	MK 2
B10122.0	—	22.00	207.0	107.0	8	MK 2
B1017/8	7/8	22.22	207.0	107.0	8	MK 2
B10123.0	—	23.00	207.0	107.0	8	MK 2
B10124.0	—	24.00	242.0	115.0	8	MK 3
B10125.0	—	25.00	242.0	115.0	10	MK 3
B1011	1"	25.40	242.0	115.0	10	MK 3
B10126.0	—	26.00	242.0	115.0	10	MK 3
B10127.0	—	27.00	251.0	124.0	10	MK 3
B10128.0	—	28.00	251.0	124.0	10	MK 3
B1011.1/8	1.1/8	28.58	251.0	124.0	10	MK 3
B10129.0	—	29.00	251.0	124.0	10	MK 3
B10130.0	—	30.00	251.0	124.0	10	MK 3
B10131.0	—	31.00	260.0	133.0	10	MK 3
B1011.1/4	1.1/4	31.75	260.0	133.0	10	MK 3



Produit	DC	DC	OAL	LCF	NOF	CZC MS
	(inch)	(mm)	(mm)	(mm)		
B10132.0	–	32.00	293.0	133.0	10	MK 4
B10134.0	–	34.00	302.0	142.0	10	MK 4
B1011.3/8	1.3/8	34.93	302.0	142.0	10	MK 4
B10135.0	–	35.00	302.0	142.0	10	MK 4
B10136.0	–	36.00	302.0	142.0	10	MK 4
B10137.0	–	37.00	302.0	142.0	10	MK 4
B10138.0	–	38.00	312.0	152.0	10	MK 4
B1011.1/2	1.1/2	38.10	312.0	152.0	10	MK 4
B10139.0	–	39.00	312.0	152.0	10	MK 4
B10140.0	–	40.00	312.0	152.0	10	MK 4
B10141.0	–	41.00	312.0	152.0	10	MK 4

Produit	DC	DC	OAL	LCF	NOF	CZC MS
	(inch)	(mm)	(mm)	(mm)		
B10142.0	–	42.00	312.0	152.0	10	MK 4
B10143.0	–	43.00	323.0	163.0	10	MK 4
B10144.0	–	44.00	323.0	163.0	10	MK 4
B1011.3/4	1.3/4	44.45	323.0	163.0	10	MK 4
B10145.0	–	45.00	323.0	163.0	12	MK 4
B10146.0	–	46.00	323.0	163.0	12	MK 4
B10147.0	–	47.00	323.0	163.0	12	MK 4
B10148.0	–	48.00	334.0	174.0	12	MK 4
B10150.0	–	50.00	334.0	174.0	12	MK 4
B1012	2"	50.80	334.0	174.0	12	MK 4



B121



Alésoir de chaudronnerie en HSS à queue cône morse

Alésoir conçu pour réaligner les trous dans les grandes fabrications où deux ou plusieurs pièces sont assemblées, avant de les boulonner ou de les riveter. Le petit diamètre pilote de l'entrée conique de rapport 1 à 10 simplifie le repérage et l'alignement de l'outil dans les trous pré-perçés. Convient pour l'alésage dans de nombreux matériaux.

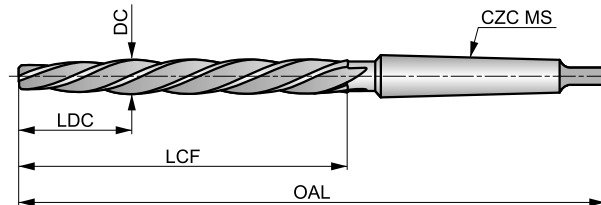

HSS	Bright ST	DIN 311
R		k11

Adéquation du groupe de matériaux de la pièce, valeurs de départ pour la vitesse de coupe (m/min) et code Alpha d'avance. Les tableaux d'avances par tour se trouvent à partir de la page 251.

P1.1 ■ 15 C	P1.2 ■ 16 C	P1.3 ■ 17 C	P2.1 ■ 13 C	P2.2 ■ 11 C	P2.3 ▣ 10 B	P3.1 ■ 7 B	P3.2 ■ 6 B	P3.3 ▣ 5 B	P4.1 ■ 4 B	P4.2 ▣ 4 B	P4.3 ▣ 3 A	K1.1 ■ 14 E	K1.2 ■ 10 D
K1.3 ▣ 8 D	K2.1 ■ 12 C	K2.2 ■ 10 C	K2.3 ▣ 8 C	K3.1 ▣ 11 C	K3.2 ▣ 8 C	N1.1 ▣ 23 F	N1.2 ■ 17 F	N1.3 ■ 9 F	N2.1 ▣ 21 E	N2.2 ■ 18 E	N2.3 ▣ 14 E	N3.1 ■ 34 D	N3.2 ■ 20 E
N3.3 ▣ 10 D	N4.1 ▣ 21 B												

Avec cône d'entrée 1:10 (LDC).

Produit	DC (mm)	OAL (mm)	LCF (mm)	LDC (mm)	NOF	CZC MS
B12110.0	10.00	171.0	95.0	30.00	4	MK 1
B12111.0	11.00	176.0	100.0	33.00	4	MK 1
B12112.0	12.00	199.0	105.0	39.00	4	MK 2
B12113.0	13.00	199.0	105.0	39.00	4	MK 2
B12114.0	14.00	209.0	115.0	42.00	4	MK 2
B12115.0	15.00	219.0	125.0	45.00	4	MK 2
B12116.0	16.00	229.0	135.0	48.00	4	MK 2
B12117.0	17.00	251.0	135.0	51.00	4	MK 3
B12118.0	18.00	261.0	145.0	58.00	4	MK 3
B12119.0	19.00	261.0	145.0	58.00	4	MK 3
B12120.0	20.00	271.0	155.0	62.00	4	MK 3
B12121.0	21.00	271.0	155.0	62.00	4	MK 3
B12122.0	22.00	281.0	165.0	66.00	4	MK 3
B12123.0	23.00	281.0	165.0	66.00	4	MK 3
B12124.0	24.00	296.0	180.0	72.00	4	MK 3
B12125.0	25.00	296.0	180.0	72.00	4	MK 3
B12126.0	26.00	296.0	180.0	72.00	4	MK 3
B12130.0	30.00	311.0	195.0	78.00	5	MK 3



B954



Alésoir machine en HSS-E pour goupille conique, à queue cône morse, conicité 1:50

Alésoir avec une coupe douce, une précision et des performances améliorées obtenus grâce au fort angle d'hélice spécialement conçue à gauche et à la coupe à droite. Conçu pour la finition des trous de goupilles coniques métriques standard de rapport 1 à 50. Convient pour l'alésage dans de nombreux matériaux.

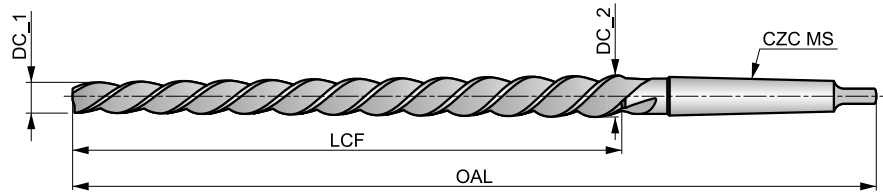

HSS-E	Bright	DIN 2180
R		1:50

Adéquation du groupe de matériaux de la pièce, valeurs de départ pour la vitesse de coupe (m/min) et code Alpha d'avance. Les tableaux d'avances par tour se trouvent à partir de la page 251.

P1.1 ■ 10 B	P1.2 ■ 12 B	P1.3 ■ 13 B	P2.1 ■ 9 B	P2.2 ■ 8 B	P2.3 ▣ 6 A	P3.1 ■ 7 A	P3.2 ■ 6 A	P3.3 ▣ 3 A	P4.1 ■ 4 A	P4.2 ▣ 3 A	P4.3 ▣ 2 A	M1.1 ▣ 11 C	M1.2 ▣ 10 B
M2.1 ▣ 9 B	M2.2 ▣ 8 B	K1.1 ■ 10 C	K1.2 ■ 6 B	K1.3 ▣ 4 B	K2.1 ■ 8 A	K2.2 ■ 6 A	K2.3 ▣ 4 A	K3.1 ■ 11 A	K3.2 ▣ 8 A	N1.1 ▣ 14 F	N1.2 ■ 12 F	N1.3 ■ 9 F	N2.1 ■ 16 E
N2.2 ■ 14 E	N2.3 ▣ 10 E	N3.1 ■ 22	N3.2 ■ 14 E	N3.3 ▣ 6	N4.1 ▣ 22 B								

Produit	nom d	DC_1	DC_2	OAL	LCF	NOF	CZC MS
		(mm)	(mm)	(mm)	(mm)		
B9545.0	5.0	4.90	6.36	155.0	73.0	3	MK 1
B9546.0	6.0	5.90	8.00	187.0	105.0	3	MK 1
B9548.0	8.0	7.90	10.80	227.0	145.0	3	MK 1
B95410.0	10.0	9.90	13.40	257.0	175.0	3	MK 1
B95412.0	12.0	11.80	16.00	315.0	210.0	3	MK 2
B95413.0	13.0	12.86	16.74	295.0	194.0	3	MK 2
B95414.0	14.0	13.86	17.74	295.0	194.0	3	MK 2
B95416.0	16.0	15.80	20.40	335.0	230.0	3	MK 2
B95420.0	20.0	19.80	24.80	377.0	250.0	3	MK 3
B95425.0	25.0	24.70	30.70	427.0	300.0	3	MK 3
B95430.0	30.0	29.70	36.10	475.0	320.0	4	MK 4



B955



Alésoir creux en HSS-E avec précision H7, brillant et trempé à la vapeur

Alésoir à creux à utiliser avec un porte-alésoir qui s'adapte au trou de l'alésoir. Ils sont rectifiés avec précision et possède une hélice à gauche et une coupe à droite pour assurer un alésage en douceur. Avec une entrée biseautée à 45° pour un positionnement et un centrage précis dans le trou afin d'améliorer les performances et la qualité du trou. Convient pour l'alésage dans de nombreux matériaux.

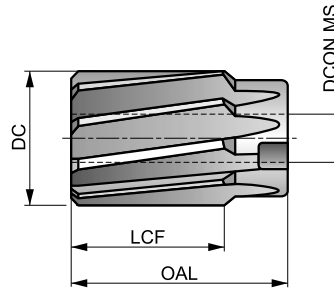

HSS-E	Bright ST	DIN 219
R	B	H7

Adéquation du groupe de matériaux de la pièce, valeurs de départ pour la vitesse de coupe (m/min) et code Alpha d'avance. Les tableaux d'avances par tour se trouvent à partir de la page 251.

P1.1 ■ 15 C	P1.2 ■ 16 C	P1.3 ■ 17 C	P2.1 ■ 13 C	P2.2 ■ 11 C	P2.3 ▧ 10 B	P3.1 ■ 7 B	P3.2 ■ 6 B	P3.3 ▧ 5 B	P4.1 ■ 4 B	P4.2 ▧ 4 B	P4.3 ▧ 3 A	M1.1 ▧ 11 C	M1.2 ▧ 10 B
M2.1 ▧ 9 B	K1.1 ■ 10 E	K1.2 ■ 8 D	K1.3 ▧ 7 D	K2.1 ■ 10 C	K2.2 ■ 9 C	K2.3 ▧ 6 C	K3.1 ▧ 10 C	K3.2 ▧ 7 C	N1.1 ▧ 17 F	N1.2 ■ 17 F	N1.3 ■ 10 F	N2.1 ▧ 23 E	N2.2 ■ 21 E
N2.3 ■ 13 E	N3.1 ■ 34 D	N3.2 ■ 20 E	N3.3 ▧ 10 D	N4.1 ▧ 24 C									

Produit	DC (mm)	OAL (mm)	LCF (mm)	NOF	DCON MS (mm)
B95525.0	25.00	45.0	32.0	8	13.00
B95526.0	26.00	45.0	32.0	8	13.00
B95527.0	27.00	45.0	32.0	8	13.00
B95528.0	28.00	45.0	32.0	8	13.00
B95529.0	29.00	45.0	32.0	8	13.00
B95530.0	30.00	45.0	32.0	8	13.00
B95531.0	31.00	50.0	36.0	10	16.00
B95532.0	32.00	50.0	36.0	10	16.00
B95534.0	34.00	50.0	36.0	10	16.00
B95535.0	35.00	50.0	36.0	10	16.00
B95536.0	36.00	56.0	40.0	10	19.00
B95537.0	37.00	56.0	40.0	10	19.00
B95538.0	38.00	56.0	40.0	10	19.00
B95540.0	40.00	56.0	40.0	10	19.00

Produit	DC (mm)	OAL (mm)	LCF (mm)	NOF	DCON MS (mm)
B95542.0	42.00	56.0	40.0	10	19.00
B95544.0	44.00	63.0	45.0	12	22.00
B95545.0	45.00	63.0	45.0	12	22.00
B95548.0	48.00	63.0	45.0	12	22.00
B95550.0	50.00	63.0	45.0	12	22.00
B95552.0	52.00	71.0	50.0	12	27.00
B95555.0	55.00	71.0	50.0	12	27.00
B95558.0	58.00	71.0	50.0	12	27.00
B95560.0	60.00	71.0	50.0	12	27.00
B95565.0	65.00	80.0	56.0	14	32.00
B95570.0	70.00	80.0	56.0	14	32.00
B95575.0	75.00	90.0	63.0	14	40.00
B95580.0	80.00	90.0	63.0	14	40.00



B956



Porte-alésoir creux pour B955

Porte-alésoir utilisé pour maintenir les alésoirs creux dans les applications sur machines. Il a une queue conique pour être monté directement dans la broche de la machine. Pour les pièces détachées du porte-alésoir (tournevis, écrous et rondelles), veuillez consulter la gamme B957 de Dormer pour connaître la disponibilité.

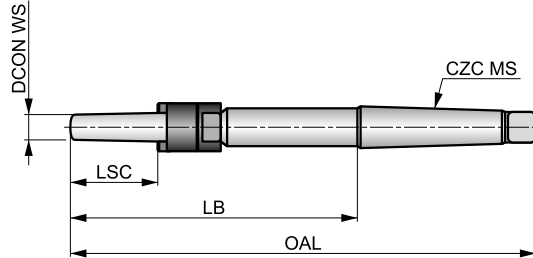

HSS-E	Bright	DIN 217

Produit	DCON WS	OAL	LSC	LB	CZC MS
	(mm)	(mm)	(mm)	(mm)	
B95613.0	13.00	250.0	45	151.00	MK 3
B95616.0	16.00	261.0	50	162.00	MK 3
B95619.0	19.00	298.0	56	174.00	MK 4
B95622.0	22.00	312.0	63	188.00	MK 4
B95627.0	27.00	359.0	71	203.00	MK 5
B95632.0	32.00	376.0	80	220.00	MK 5
B95640.0	40.00	396.0	90	240.00	MK 5



B957

DORMER



Pièces de rechange pour porte-alésoir B956

La gamme de pièces de rechange B957 pour les porte-alésoirs B956 se compose de tournevis, d'écrous et de rondelles. Elles peuvent être achetées individuellement par taille, ce qui garantit une utilisation continue en toute sécurité. Les tournevis, écrous et rondelles de la gamme B957 sont fabriqués conformément aux normes en vigueur.

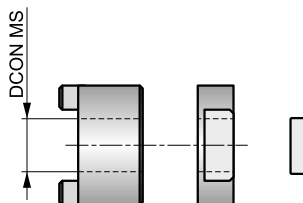

Produit	Nr.	DCON MS
		(mm)
B957N3DRIVER	3	13.00
B957N3NUT	3	–
B957N3WASHER	3	–
B957N4DRIVER	4	16.00
B957N4NUT	4	–
B957N4WASHER	4	–
B957N5DRIVER	5	19.00
B957N5NUT	5	–
B957N5WASHER	5	–
B957N6DRIVER	6	22.00
B957N6NUT	6	–
B957N6WASHER	6	–
B957N7DRIVER	7	27.00
B957N7NUT	7	–
B957N7WASHER	7	–
B957N8DRIVER	8	32.00
B957N8NUT	8	–
B957N8WASHER	8	–
B957N9DRIVER	9	40.00
B957N9NUT	9	–
B957N9WASHER	9	–



G400



Fraise en carbure à ébavurer et à chanfreiner à 90° à queue cylindrique, finition brillante

Fraise à chanfreiner 90° haute performance avec finition brillante, conçue pour être utilisée sur des machines CNC où une productivité et une qualité élevée sont requises. Peut être utilisée pour chanfreiner des trous dans des matériaux durs et abrasifs. L'angle de 90° permet de chanfreiner les trous de fixation standards pour des vis à têtes fraisées à 90°.

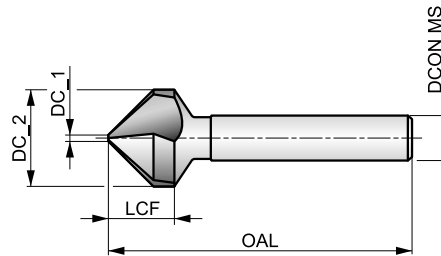

HM	Bright	DIN 335C
R	90°	

Adéquation du groupe de matériaux de la pièce, valeurs de départ pour la vitesse de coupe (m/min) et code Alpha d'avance. Les tableaux d'avances par tour se trouvent à partir de la page 251.

P1.1 ■ 64 E	P1.2 ■ 72 E	P1.3 ■ 74 E	P2.1 ■ 55 E	P2.2 ■ 48 D	P2.3 ■ 43 B	P3.1 ■ 45 D	P3.2 ■ 36 D	P3.3 ■ 30 B	P4.1 ■ 26 D	P4.2 ■ 23 B	P4.3 ■ 18 A	M1.1 ■ 24 C	M1.2 ■ 21 C
M2.1 ■ 22 C	M2.2 ▣ 18 C	M2.3 ▣ 15 B	M3.1 ■ 20 B	M3.2 ▣ 17 B	M3.3 ▣ 15 B	M4.1 ▣ 15 A	M4.2 ▣ 13 A	K1.1 ■ 45 F	K1.2 ■ 33 D	K1.3 ■ 25 D	K2.1 ■ 46 C	K2.2 ■ 37 C	K2.3 ▣ 30 C
K3.1 ■ 41 C	K3.2 ■ 31 C	K3.3 ▣ 25 C	K4.1 ■ 38 C	K4.2 ■ 28 C	K4.3 ■ 21 C	K4.4 ▣ 18 C	K4.5 ▣ 15 C	K5.1 ■ 43 C	K5.2 ■ 32 C	K5.3 ■ 25 C	N1.1 ▣ 75 G	N1.2 ■ 55 G	N1.3 ■ 40 F
N2.1 ■ 40 F	N2.2 ■ 36 F	N2.3 ■ 26 F	N3.1 ■ 42 F	N3.2 ■ 25 F	N3.3 ▣ 13 D	N4.3 ■ 17 E	S1.1 ■ 12 C	S1.2 ■ 10 A	S1.3 ▣ 9 A	S2.1 ■ 8 B	S2.2 ▣ 7 A	S3.1 ■ 6 B	S3.2 ▣ 5 A
S4.1 ■ 5 B	S4.2 ▣ 4 A	H1.1 ■ 12 A	H2.1 ■ 7 A	H2.2 ▣ 6 B	H3.1 ■ 8 A	H3.2 ▣ 7 B	H4.1 ■ 5 A	H4.2 ▣ 4 B					

DCON MS tolérance h6.

Produit	DC_2 (mm)	DC_1 (mm)	LCF (mm)	OAL (mm)	DCON MS (mm)	NOF
G4006.3	6.30	1.50	5.0	45.0	5.00	3
G4008.3	8.30	2.00	6.0	50.0	6.00	3
G40010.4	10.40	2.50	7.1	50.0	6.00	3
G40012.4	12.40	2.80	8.0	56.0	8.00	3
G40016.5	16.50	3.20	10.0	60.0	10.00	3
G40020.5	20.50	3.50	12.5	63.0	10.00	3
G40025.0	25.00	3.80	15.0	67.0	10.00	3
G40031.0	31.00	4.20	18.0	71.0	12.00	3



G135

DORMER



Fraise en HSS à ébavurer et à chanfreiner à 60° à queue cylindrique, finition brillante

Fraise à chanfreiner à 60° pour les trous de fixation spéciaux et pour éliminer les bavures des trous percés dans des diamètres allant jusqu'à 25,0 mm. S'utilise aussi bien sur machines qu'à la main. Convient pour chanfreiner les trous dans de nombreux matériaux.

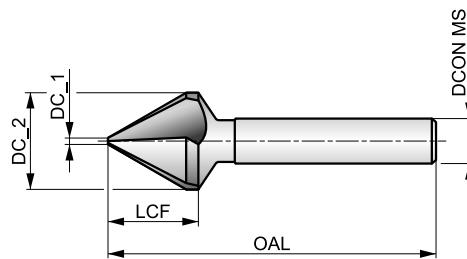

HSS	Bright	DIN 334C
R	60°	

Adéquation du groupe de matériaux de la pièce, valeurs de départ pour la vitesse de coupe (m/min) et code Alpha d'avance. Les tableaux d'avances par tour se trouvent à partir de la page 251.

P1.1 ■ 23 E	P1.2 ■ 26 E	P1.3 ■ 27 E	P2.1 ■ 20 E	P2.2 ■ 18 D	P2.3 ▣ 16 B	P3.1 ■ 16 D	P3.2 ▣ 13 D	P3.3 ▣ 11 B	P4.1 ■ 10 D	P4.2 ▣ 8 B	M1.1 ▣ 8 C	M1.2 ▣ 6 C	M2.1 ▣ 7 C
M2.2 ▣ 6 C	K1.1 ▣ 20 F	K1.2 ▣ 15 D	K2.1 ▣ 21 C	K2.2 ▣ 17 C	K3.1 ▣ 18 C	K3.2 ▣ 14 C	K5.1 ▣ 19 C	K5.2 ▣ 15 C	N1.1 ▣ 40 G	N1.2 ■ 30 G	N1.3 ▣ 20 F	N2.1 ■ 20 F	N2.2 ▣ 18 F
N3.1 ■ 21 F	N3.2 ■ 12 F	N3.3 ▣ 6 D	N4.1 ▣ 40 G	N4.2 ▣ 35 G									

DCON MS tolérance h9.

Produit	DC_2 (mm)	DC_1 (mm)	LCF (mm)	OAL (mm)	DCON MS (mm)	NOF
G1356.3	6.30	1.60	6.8	45.0	5.00	3
G1358.0	8.00	2.00	8.5	50.0	6.00	3
G13510.0	10.00	2.50	7.6	50.0	6.00	3
G13512.5	12.50	3.20	11.7	56.0	8.00	3
G13516.0	16.00	4.00	14.5	63.0	10.00	3
G13520.0	20.00	5.00	17.5	67.0	10.00	3
G13525.0	25.00	6.30	20.5	71.0	10.00	3



G335



Fraise en HSS à ébavurer et à chanfreiner à 60° à queue cylindrique, revêtement TiN

Fraise à chanfreiner des trous à 60° pour les trous de fixation spéciaux et pour éliminer les bavures des trous percés. Le revêtement TiN améliore les performances et prolonge la durée de vie de l'outil. Fraise polyvalente qui peut être utilisée aussi bien à la main qu'en machine. Convient pour chanfreiner les trous dans de nombreux matériaux.

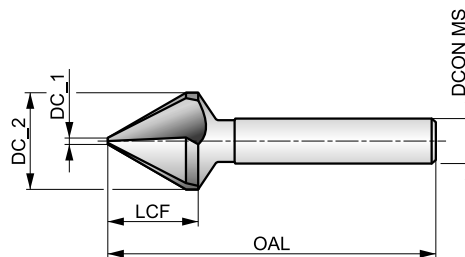

HSS	TiN	DIN 334C
R	60°	

Adéquation du groupe de matériaux de la pièce, valeurs de départ pour la vitesse de coupe (m/min) et code Alpha d'avance. Les tableaux d'avances par tour se trouvent à partir de la page 251.

P1.1 ■ 33 E	P1.2 ■ 37 E	P1.3 ■ 38 E	P2.1 ■ 28 E	P2.2 ■ 25 D	P2.3 ■ 22 B	P3.1 ■ 23 D	P3.2 ■ 18 D	P3.3 ■ 15 B	P4.1 ■ 13 D	P4.2 ■ 11 B	P4.3 ■ 9 B	M1.1 ■ 10 C	M1.2 ■ 8 C
M2.1 ■ 19 C	M3.1 ■ 8 B	K1.1 ■ 34 F	K1.2 ■ 25 D	K1.3 ■ 19 D	K2.1 ■ 35 C	K2.2 ■ 28 C	K2.3 ■ 23 C	K3.1 ■ 31 C	K3.2 ■ 24 C	K3.3 ■ 19 C	K4.1 ■ 29 C	K4.2 ■ 22 C	K4.3 ■ 16 C
K5.1 ■ 32 C	K5.2 ■ 24 C	K5.3 ■ 19 C	N1.1 ■ 53 G	N1.2 ■ 40 G	N1.3 ■ 27 F	N2.1 ■ 27 F	N2.2 ■ 24 F	N2.3 ■ 17 F	N3.1 ■ 28 F	N3.2 ■ 16 F	N3.3 ■ 8 D	N4.1 ■ 58 G	N4.2 ■ 50 G

DCON MS tolérance h9.

Produit	DC_2 (mm)	DC_1 (mm)	LCF (mm)	OAL (mm)	DCON MS (mm)	NOF
G3356.3	6.30	1.60	6.8	45.0	5.00	3
G3358.0	8.00	2.00	8.5	50.0	6.00	3
G33510.0	10.00	2.50	7.6	50.0	6.00	3
G33512.5	12.50	3.20	11.7	56.0	8.00	3
G33516.0	16.00	4.00	14.5	63.0	10.00	3
G33520.0	20.00	5.00	17.5	67.0	10.00	3
G33525.0	25.00	6.30	20.5	71.0	10.00	3



G137



Fraise en HSS à ébavurer et à chanfreiner à 60° à queue cône morse, finition brillante

Fraises à chanfreiner à finition brillante avec un angle de 60° pour les trous de fixation spéciaux et pour éliminer les bavures des trous percés. La conception de la queue conique permet d'utiliser l'outil dans des applications sur machines où il est maintenu directement dans la broche. Convient pour chanfreiner les trous dans de nombreux matériaux.

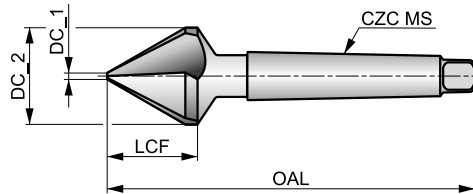

HSS	Bright	DIN 334D
R	60°	

Adéquation du groupe de matériaux de la pièce, valeurs de départ pour la vitesse de coupe (m/min) et code Alpha d'avance. Les tableaux d'avances par tour se trouvent à partir de la page 251.

P1.1 ■ 23 E	P1.2 ■ 26 E	P1.3 ■ 27 E	P2.1 ■ 20 E	P2.2 ■ 18 D	P2.3 ▣ 16 B	P3.1 ■ 16 D	P3.2 ▣ 13 D	P3.3 ▣ 11 B	P4.1 ■ 10 D	P4.2 ▣ 8 B	M1.1 ▣ 8 C	M1.2 ▣ 6 C	M2.1 ▣ 7 C
M2.2 ▣ 6 C	K1.1 ▣ 20 F	K1.2 ▣ 15 D	K2.1 ▣ 21 C	K2.2 ▣ 17 C	K3.1 ▣ 18 C	K3.2 ▣ 14 C	K5.1 ▣ 19 C	K5.2 ▣ 15 C	N1.1 ▣ 40 G	N1.2 ■ 30 G	N1.3 ▣ 20 F	N2.1 ■ 20 F	N2.2 ▣ 18 F
N3.1 ■ 21 F	N3.2 ■ 12 F	N3.3 ▣ 6 D	N4.1 ▣ 40 G	N4.2 ▣ 35 G									

Produit	DC_2 (mm)	DC_1 (mm)	LCF (mm)	OAL (mm)	CZC MS	NOF
G13716.0	16.00	4.00	14.5	90.0	MK 1	3
G13720.0	20.00	5.00	17.5	106.0	MK 2	3
G13725.0	25.00	6.30	20.0	112.0	MK 2	3
G13731.5	31.50	10.00	23.0	118.0	MK 2	3
G13740.0	40.00	12.50	28.5	150.0	MK 3	3
G13750.0	50.00	16.00	36.0	160.0	MK 3	3
G13763.0	63.00	20.00	43.0	190.0	MK 4	3
G13780.0	80.00	25.00	54.0	200.0	MK 4	3



G154



Fraise en HSS à ébavurer et à chanfreiner à 82° à queue cylindrique, finition brillante

Fraise à chanfreiner à 82° pour les vis à tête plate et pour chanfreiner les trous. Fraise polyvalente qui peut être utilisée aussi bien à la main qu'en machine. Convient pour chanfreiner les trous dans de nombreux matériaux.

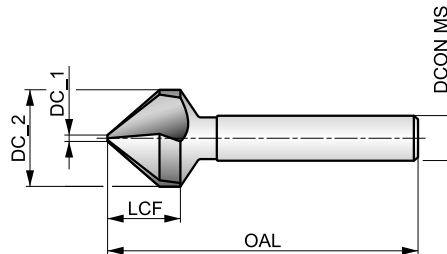

HSS	Bright	DIN 335C
R	82°	

Adéquation du groupe de matériaux de la pièce, valeurs de départ pour la vitesse de coupe (m/min) et code Alpha d'avance. Les tableaux d'avances par tour se trouvent à partir de la page 251.

P1.1 ■ 23 E	P1.2 ■ 26 E	P1.3 ■ 27 E	P2.1 ■ 20 E	P2.2 ■ 18 D	P2.3 ▧ 16 B	P3.1 ■ 16 D	P3.2 ■ 13 D	P3.3 ▧ 11 B	P4.1 ■ 10 D	P4.2 ▧ 8 B	M1.1 ▧ 8 C	M1.2 ▧ 6 C	M2.1 ▧ 7 C
M2.2 ▧ 16 C	K1.1 ▧ 20 F	K1.2 ▧ 15 D	K2.1 ▧ 21 C	K2.2 ▧ 17 C	K3.1 ▧ 18 C	K3.2 ▧ 14 C	K5.1 ▧ 14 C	K5.2 ▧ 10 C	N1.1 ▧ 40 G	N1.2 ■ 30 G	N1.3 ▧ 20 F	N2.1 ■ 20 F	N2.2 ▧ 18 F
N3.1 ■ 21 F	N3.2 ■ 12 F	N3.3 ▧ 6 D	N4.1 ▧ 40 G	N4.2 ▧ 35 G									

DCON MS tolérance h9.

Produit	DC_2 (mm)	DC_1 (mm)	LCF (mm)	OAL (mm)	DCON MS (mm)	NOF
G1546.3	6.30	1.50	5.5	45.0	5.00	3
G1548.3	8.30	2.00	6.5	50.0	6.00	3
G15410.4	10.40	2.50	7.6	50.0	6.00	3
G15412.4	12.40	2.80	8.5	56.0	8.00	3
G15416.5	16.50	3.20	10.5	60.0	10.00	3
G15420.5	20.50	3.50	13.0	63.0	10.00	3
G15425.0	25.00	3.80	15.5	67.0	10.00	3



G129



Fraise en HSS à ébavurer et à chanfreiner à 90° à une dent et à queue cylindrique, finition brillante

Fraise à chanfreiner à 90° avec une finition brillante pour chanfreiner et pour éliminer les bavures des trous percés. La conception à une seule dent réduit les vibrations et le broutage pour une opération de chanfreinage en douceur. Convient pour chanfreiner les trous dans les aciers doux et les matériaux non ferreux de résistance moyenne, tels que l'aluminium.

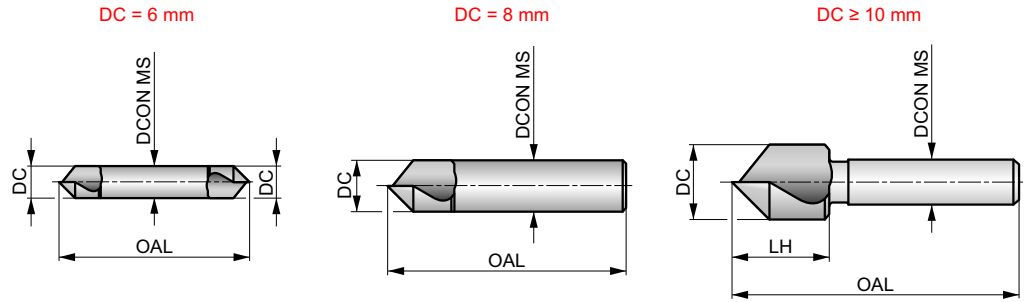

HSS	Bright	DORMER
R	90°	

Adéquation du groupe de matériaux de la pièce, valeurs de départ pour la vitesse de coupe (m/min) et code Alpha d'avance. Les tableaux d'avances par tour se trouvent à partir de la page 251.

P1.1 ■ 21 D	P1.2 ■ 24 D	P1.3 ■ 25 D	P2.1 ■ 18 D	P2.2 ■ 16 C	P2.3 ▣ 14 A	P3.1 ■ 13 B	P3.2 ▣ 11 B	M1.1 ▣ 8 B	M1.2 ▣ 6 B	M2.1 ▣ 7 B	K1.1 ▣ 18 D	K1.2 ▣ 13 C	K2.1 ▣ 19 A
K2.2 ▣ 15 A	K3.1 ▣ 16 A	K3.2 ▣ 12 A	N1.1 ■ 34 D	N1.2 ■ 25 D	N1.3 ▣ 16 C	N2.1 ▣ 16 C	N2.2 ▣ 14 C	N3.1 ■ 17 C	N3.2 ■ 9 C	N3.3 ▣ 5 B	N4.1 ▣ 35 D	N4.2 ▣ 30 D	

DCON MS tolérance h9.

Produit	DC (mm)	LH (mm)	OAL (mm)	DCON MS (mm)	NOF
G1296.0	6.00	—	45.0	6.00	1
G1298.0	8.00	—	50.0	8.00	1
G12910.0	10.00	17.0	49.0	8.00	1
G12912.5	12.50	17.0	49.0	8.00	1
G12916.0	16.00	20.0	56.0	10.00	1
G12920.0	20.00	24.0	60.0	10.00	1
G12925.0	25.00	25.0	75.0	12.00	1
G12931.5	31.50	29.0	80.0	12.00	1



G149



Fraise en HSS-E à ébavurer et à chanfreiner à 90° à queue cylindrique, avec trou, finition brillante

Fraise à chanfreiner à 90° conçue pour les trous de fixation et les opérations d'ébavurage. Sa conception spécifique améliore l'évacuation des copeaux pour une opération de chanfreinage en douceur. Convient pour de très nombreux matériaux.

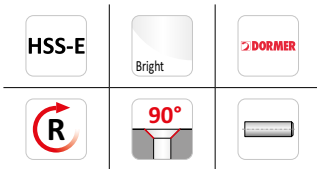
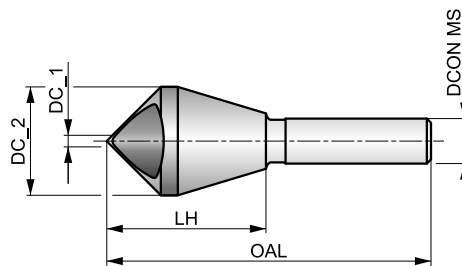

Adéquation du groupe de matériaux de la pièce, valeurs de départ pour la vitesse de coupe (m/min) et code Alpha d'avance. Les tableaux d'avances par tour se trouvent à partir de la page 251.

P1.1 ▣ 21 D	P1.2 ▣ 24 D	P1.3 ▣ 25 D	P2.1 ▣ 18 D	P2.2 ▣ 16 C	P2.3 ▣ 14 A	P3.1 ▣ 16 B	P3.2 ▣ 13 B	M1.1 ▣ 8 B	M1.2 ▣ 6 B	M2.1 ▣ 7 B	K1.1 ▣ 18 D	K2.1 ▣ 19 A	K3.1 ▣ 16 A
K5.1 ▣ 14 A	N1.1 ▣ 34 D	N1.2 ▣ 25 D	N1.3 ▣ 16 C	N2.1 ▣ 16 C	N2.2 ▣ 14 C	N3.1 ▣ 17 C	N3.2 ▣ 9 C	N3.3 ▣ 5 B	N4.1 ▣ 17 D	N4.2 ▣ 5 D			

Produit	DC_2	DC_1	LH	OAL	DCON MS	DC	NOF
	(mm)	(mm)	(mm)	(mm)	(mm)	(mm)	
G1495	5.00	2.00	19.0	45.0	6.00	10.00	1
G14910	10.00	5.00	23.0	48.0	8.00	14.00	1
G14915	15.00	10.00	34.0	65.0	10.00	21.00	1
G14920	20.00	15.00	43.0	84.0	12.00	28.00	1
G14925	25.00	20.00	48.0	102.0	15.00	35.00	1
G14930	30.00	25.00	61.0	115.0	15.00	44.00	1
G14935	35.00	30.00	65.0	127.0	15.00	48.00	1
G14940	40.00	35.00	66.0	136.0	15.00	53.00	1
G14950	50.00	40.00	85.0	166.0	20.00	60.00	1



G136



Fraise en HSS à ébavurer et à chanfreiner à 90° à queue cylindrique, finition brillante

Fraise à chanfreiner à 90° conçue pour les trous de fixation standards et réaliser des opérations d'ébavurage. Sa queue réduite permet de réaliser des chanfreins d'un plus grand diamètre. Fraise polyvalente adaptée aussi bien aux applications électro-portatives que sur machines dans de très nombreux matériaux

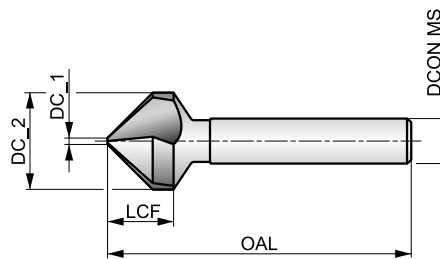

HSS	Bright	DIN 335C
R	90°	

Adéquation du groupe de matériaux de la pièce, valeurs de départ pour la vitesse de coupe (m/min) et code Alpha d'avance. Les tableaux d'avances par tour se trouvent à partir de la page 251.

P1.1 ■ 23 E	P1.2 ■ 26 E	P1.3 ■ 27 E	P2.1 ■ 20 E	P2.2 ■ 18 D	P2.3 ▣ 16 B	P3.1 ■ 16 D	P3.2 ■ 13 D	P3.3 ▣ 11 B	P4.1 ■ 10 D	P4.2 ▣ 8 B	M1.1 ▣ 8 C	M1.2 ▣ 6 C	M2.1 ▣ 7 C
M2.2 ▣ 16 C	K1.1 ▣ 20 F	K1.2 ▣ 15 D	K2.1 ▣ 21 C	K2.2 ▣ 17 C	K3.1 ▣ 18 C	K3.2 ▣ 14 C	K5.1 ▣ 19 C	K5.2 ▣ 15 C	N1.1 ▣ 40 G	N1.2 ■ 30 G	N1.3 ▣ 20 F	N2.1 ■ 20 F	N2.2 ▣ 18 F
N3.1 ■ 21 F	N3.2 ■ 12 F	N3.3 ▣ 6 D	N4.1 ▣ 40 G	N4.2 ▣ 35 G									

DCON MS tolérance h9.

Les produits de cette série sont également disponibles en coffret. Voir G236.

Produit	DC_2 (mm)	DC_1 (mm)	LCF (mm)	OAL (mm)	DCON MS (mm)	NOF
G1364.3	4.30	1.30	4.0	40.0	4.00	3
G1365.0	5.00	1.50	4.5	40.0	4.00	3
G1365.3	5.30	1.50	4.5	40.0	4.00	3
G1365.8	5.80	1.50	5.0	45.0	5.00	3
G1366.0	6.00	1.50	5.0	45.0	5.00	3
G1366.3	6.30	1.50	5.5	45.0	5.00	3
G1367.0	7.00	1.80	5.5	50.0	6.00	3
G1367.3	7.30	1.80	6.1	50.0	6.00	3
G1368.0	8.00	2.00	6.1	50.0	6.00	3
G1368.3	8.30	2.00	6.5	50.0	6.00	3
G1369.4	9.40	2.20	7.2	50.0	6.00	3
G13610.0	10.00	2.50	7.6	50.0	6.00	3
G13610.4	10.40	2.50	7.6	50.0	6.00	3

Produit	DC_2 (mm)	DC_1 (mm)	LCF (mm)	OAL (mm)	DCON MS (mm)	NOF
G13611.5	11.50	2.80	8.0	56.0	8.00	3
G13612.4	12.40	2.80	8.5	56.0	8.00	3
G13613.4	13.40	2.90	9.0	56.0	8.00	3
G13615.0	15.00	3.20	9.5	60.0	10.00	3
G13616.5	16.50	3.20	10.5	60.0	10.00	3
G13619.0	19.00	3.50	11.7	63.0	10.00	3
G13620.5	20.50	3.50	13.0	63.0	10.00	3
G13623.0	23.00	3.80	13.7	67.0	10.00	3
G13625.0	25.00	3.80	15.5	67.0	10.00	3
G13626.0	26.00	3.80	15.5	67.0	10.00	3
G13628.0	28.00	4.00	16.5	71.0	12.00	3
G13630.0	30.00	4.20	18.5	71.0	12.00	3
G13631.0	31.00	4.20	18.5	71.0	12.00	3



G560



Fraise en HSS à ébavurer et à chanfreiner à 90° à queue cylindrique, revêtement TiAlN

Fraise à chanfreiner à 90° conçue pour chanfreiner les trous de fixation standards et réaliser des opérations d'ébavurage. Sa queue réduite en diamètre permet de réaliser des chanfreins d'un plus grand diamètre. Fraise polyvalente adaptée aussi bien aux applications électro-portatives que sur machines. Son revêtement TiAlN améliore les performances et prolonge la durée de vie de l'outil.

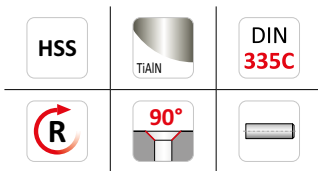
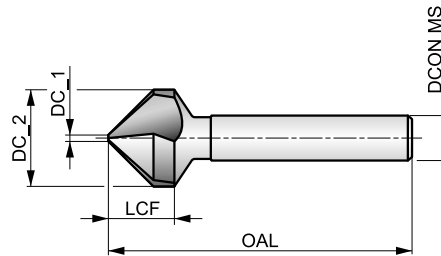

Adéquation du groupe de matériaux de la pièce, valeurs de départ pour la vitesse de coupe (m/min) et code Alpha d'avance. Les tableaux d'avances par tour se trouvent à partir de la page 251.

P1.1 ■ 40 E	P1.2 ■ 45 E	P1.3 ■ 46 E	P2.1 ■ 34 E	P2.2 ■ 30 D	P2.3 ■ 27 B	P3.1 ■ 28 D	P3.2 ■ 22 D	P3.3 ■ 19 B	P4.1 ■ 16 D	P4.2 ■ 14 B	P4.3 ▣ 11 B	M1.1 ▣ 11 C	M1.2 ▣ 9 C
M2.1 ▣ 10 C	M2.2 ▣ 9 C	M2.3 ▣ 8 B	K1.1 ■ 41 F	K1.2 ■ 30 D	K1.3 ▣ 23 D	K2.1 ■ 42 C	K2.2 ■ 34 C	K2.3 ▣ 27 C	K3.1 ■ 37 C	K3.2 ■ 28 C	K3.3 ▣ 23 C	K4.1 ▣ 34 C	K4.2 ▣ 26 C
K4.3 ▣ 19 C	K5.1 ■ 39 C	K5.2 ■ 29 C	K5.3 ▣ 23 C	N1.1 ▣ 60 G	N1.2 ▣ 45 G	N1.3 ■ 30 F	N2.1 ■ 30 F	N2.2 ■ 27 F	N2.3 ■ 19 F	N3.1 ■ 32 F	N3.2 ■ 18 F	N3.3 ▣ 19 D	N4.1 ▣ 62 G
N4.2 ▣ 55 G													

DCON MS tolérance h9.

Les produits de cette série sont également disponibles en coffret. Voir G236.

Produit	DC_2 (mm)	DC_1 (mm)	LCF (mm)	OAL (mm)	DCON MS (mm)	NOF
G5606.3	6.30	1.50	5.5	45.0	5.00	3
G5608.0	8.00	2.00	6.1	50.0	6.00	3
G5608.3	8.30	2.00	6.5	50.0	6.00	3
G56010.0	10.00	2.50	7.6	50.0	6.00	3
G56010.4	10.40	2.50	7.6	50.0	6.00	3
G56012.4	12.40	2.80	8.5	56.0	8.00	3
G56016.5	16.50	3.20	10.5	60.0	10.00	3
G56020.5	20.50	3.50	13.0	63.0	10.00	3
G56025.0	25.00	3.80	15.5	67.0	10.00	3
G56031.0	31.00	4.20	18.5	71.0	12.00	3



G106



Fraise en HSS à ébavurer et à chanfreiner à 90° à queue cylindrique à 3 méplats, finition brillante

Fraise chanfreiner à 90° conçue pour les trous de fixation standards et réaliser des opérations d'ébavurage. La queue à trois méplats rectifiés permet une meilleure tenue dans les mandrins à trois mors, en particulier lors de l'utilisation d'outils électro-portatifs. Convient pour chanfreiner dans de très nombreux matériaux.

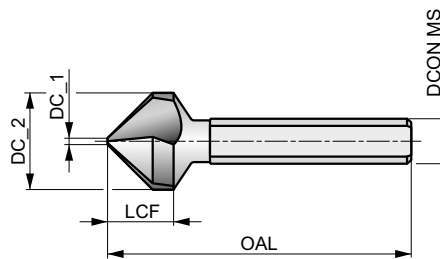

HSS	Bright	DIN 335C
R	90°	

Adéquation du groupe de matériaux de la pièce, valeurs de départ pour la vitesse de coupe (m/min) et code Alpha d'avance. Les tableaux d'avances par tour se trouvent à partir de la page 251.

P1.1 ■ 23 E	P1.2 ■ 26 E	P1.3 ■ 27 E	P2.1 ■ 20 E	P2.2 ■ 18 D	P2.3 ■ 16 B	P3.1 ■ 16 D	P3.2 ■ 13 D	P3.3 ■ 11 B	P4.1 ■ 10 D	P4.2 ■ 8 B	M1.1 ■ 8 C	M1.2 ■ 6 C	M2.1 ■ 7 C
M2.2 ■ 16 C	K1.1 ■ 20 F	K1.2 ■ 15 D	K2.1 ■ 21 C	K2.2 ■ 17 C	K3.1 ■ 18 C	K3.2 ■ 14 C	K5.1 ■ 19 C	K5.2 ■ 15 C	N1.1 ■ 40 G	N1.2 ■ 30 G	N1.3 ■ 20 F	N2.1 ■ 20 F	N2.2 ■ 18 F
N3.1 ■ 21 F	N3.2 ■ 12 F	N3.3 ■ 6 D	N4.1 ■ 40 G	N4.2 ■ 35 G									

DCON MS tolérance h9.

Les produits de cette série sont également disponibles en coffret. Voir G236.

Produit	DC_2 (mm)	DC_1 (mm)	LCF (mm)	OAL (mm)	DCON MS (mm)	NOF
G1066.3	6.30	1.50	5.6	45.0	5.00	3
G1068.3	8.30	2.00	6.9	50.0	6.00	3
G10610.4	10.40	2.50	7.8	50.0	6.00	3
G10612.4	12.40	2.80	8.6	56.0	8.00	3
G10616.5	16.50	3.20	11.1	60.0	10.00	3
G10620.5	20.50	3.50	12.9	63.0	10.00	3
G10625.0	25.00	3.80	15.7	67.0	10.00	3
G10631.0	31.00	4.20	18.5	71.0	12.00	3
G10634.0	34.00	4.50	19.0	103.0	16.00	3
G10637.0	37.00	4.50	21.2	118.0	16.00	3
G10640.0	40.00	4.50	20.0	118.0	16.00	3
G10650.0	50.00	5.00	23.6	126.0	16.00	3



G506



Fraise en HSS à ébavurer et à chanfreiner à 90° à queue cylindrique à 3 méplats, revêtement TiAlN

Fraise à chanfreiner à 90° conçue pour chanfreiner les trous de fixation standards et réaliser des opérations d'ébavurage. La queue à trois méplats rectifiés permet une meilleure tenue dans les mandrins à trois mors, en particulier lors de l'utilisation d'outils électro-portatifs. Son revêtement TiAlN prolonge la durée de vie de l'outil. Convient pour chanfreiner dans de très nombreux matériaux.

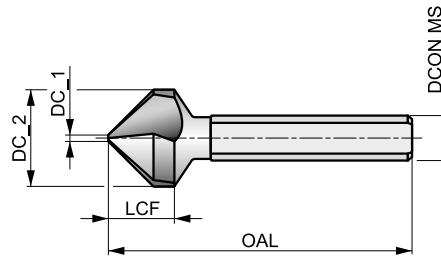

HSS	TiAlN	DIN 335C
R	90°	

Adéquation du groupe de matériaux de la pièce, valeurs de départ pour la vitesse de coupe (m/min) et code Alpha d'avance. Les tableaux d'avances par tour se trouvent à partir de la page 251.

P1.1 ■ 40 E	P1.2 ■ 45 E	P1.3 ■ 46 E	P2.1 ■ 34 E	P2.2 ■ 30 D	P2.3 ■ 27 B	P3.1 ■ 28 D	P3.2 ■ 22 D	P3.3 ■ 19 B	P4.1 ■ 16 D	P4.2 ■ 14 B	P4.3 ▧ 11 B	M1.1 ▧ 11 C	M1.2 ▧ 9 C
M2.1 ▧ 10 C	M2.2 ▧ 9 C	M2.3 ▧ 8 B	K1.1 ■ 41 F	K1.2 ■ 30 D	K1.3 ▧ 23 D	K2.1 ■ 42 C	K2.2 ■ 34 C	K2.3 ▧ 27 C	K3.1 ■ 37 C	K3.2 ■ 28 C	K3.3 ▧ 23 C	K4.1 ▧ 34 C	K4.2 ▧ 26 C
K4.3 ▧ 19 C	K5.1 ■ 39 C	K5.2 ■ 29 C	K5.3 ▧ 23 C	N1.1 ▧ 60 G	N1.2 ▧ 45 G	N1.3 ■ 30 F	N2.1 ■ 30 F	N2.2 ■ 27 F	N2.3 ■ 19 F	N3.1 ■ 32 F	N3.2 ■ 18 F	N3.3 ▧ 19 D	N4.1 ▧ 62 G
N4.2 ▧ 155 G													

DCON MS tolérance h9.

Les produits de cette série sont également disponibles en coffret. Voir G236.

Produit	DC_2	DC_1	LCF	OAL	DCON MS	NOF
	(mm)	(mm)	(mm)	(mm)	(mm)	
G5066.3	6.30	1.50	5.6	45.0	5.00	3
G5068.3	8.30	2.00	6.9	50.0	6.00	3
G50610.4	10.40	2.50	7.8	50.0	6.00	3
G50612.4	12.40	2.80	8.6	56.0	8.00	3
G50616.5	16.50	3.20	11.1	60.0	10.00	3
G50620.5	20.50	3.50	12.9	63.0	10.00	3
G50625.0	25.00	3.80	15.7	67.0	10.00	3
G50631.0	31.00	4.20	18.5	71.0	12.00	3
G50634.0	34.00	4.50	19.0	103.0	16.00	3
G50637.0	37.00	4.50	21.2	118.0	16.00	3
G50640.0	40.00	4.50	20.0	118.0	16.00	3
G50650.0	50.00	5.00	23.6	126.0	16.00	3



G142



Fraise en HSS à ébavurer et à chanfreiner à 90° à queue cylindrique, finition brillante, acier inoxydable

Fraise à chanfreiner à 90° conçue pour les trous de fixation standards et les opérations d'ébavurage. Sa géométrie positive prononcée permet d'améliorer les performances lors de l'usinage de matériaux collants, tels que les aciers inoxydables et les matériaux non ferreux. Elle peut être utilisée aussi bien pour les applications électro-portatives que sur machines.

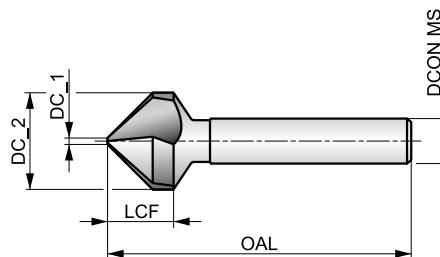

HSS	Bright	DIN 335C
R	90°	

Adéquation du groupe de matériaux de la pièce, valeurs de départ pour la vitesse de coupe (m/min) et code Alpha d'avance. Les tableaux d'avances par tour se trouvent à partir de la page 251.

P1.1 ■ 23 E	P1.2 ■ 26 E	P1.3 ■ 27 E	P2.1 ■ 20 E	P2.2 ■ 18 D	P2.3 ▣ 16 B	P3.1 ■ 16 D	P3.2 ■ 13 D	P3.3 ▣ 11 B	P4.1 ■ 10 D	P4.2 ▣ 8 B	M1.1 ■ 11 C	M1.2 ■ 9 C	M2.1 ■ 10 C
M2.2 ▣ 8 C	M3.1 ■ 7 B	M3.2 ▣ 6 B	M4.1 ▣ 4 A	N1.1 ■ 40 G	N1.2 ■ 30 G	N1.3 ▣ 20 F	N2.1 ▣ 20 F	N2.2 ▣ 18 F	N2.3 ▣ 20 F	N3.1 ■ 34 F	N3.2 ■ 20 F	N3.3 ■ 10 D	N4.1 ■ 40 G
N4.2 ■ 35 G													

DCON MS tolérance h9.

Produit	DC_2 (mm)	DC_1 (mm)	LCF (mm)	OAL (mm)	DCON MS (mm)	NOF
G1424.8	4.80	1.30	4.5	40.0	4.00	3
G1425.0	5.00	1.50	4.5	40.0	4.00	3
G1426.0	6.00	1.50	5.0	45.0	5.00	3
G1426.3	6.30	1.50	5.5	45.0	5.00	3
G1427.0	7.00	1.80	5.5	50.0	6.00	3
G1427.3	7.30	1.80	6.1	50.0	6.00	3
G1428.0	8.00	2.00	6.1	50.0	6.00	3
G1428.3	8.30	2.00	6.5	50.0	6.00	3
G14210.0	10.00	2.50	7.6	50.0	6.00	3
G14210.4	10.40	2.50	7.6	50.0	6.00	3
G14211.5	11.50	2.80	8.0	56.0	8.00	3
G14212.4	12.40	2.80	8.5	56.0	8.00	3
G14215.0	15.00	3.20	9.5	60.0	10.00	3
G14216.5	16.50	3.20	10.5	60.0	10.00	3
G14219.0	19.00	3.50	11.7	63.0	10.00	3
G14220.5	20.50	3.50	13.0	63.0	10.00	3
G14223.0	23.00	3.80	13.7	67.0	10.00	3
G14225.0	25.00	3.80	15.5	67.0	10.00	3
G14231.0	31.00	4.20	18.5	71.0	12.00	3



G570



Fraise en HSS-E à ébavurer et à chanfreiner à 90° à queue cylindrique, revêtement AlTiCN

Fraise à 90° conçue pour les trous de fixation standards et les opérations d'ébavurage. Elle peut être utilisée aussi bien pour les applications électro-portatives que sur machines. Particulièrement adaptée au chanfreinage de trous dans des matériaux durs et abrasifs. Son revêtement AlTiCN améliore les performances et prolonge la durée de vie de l'outil.

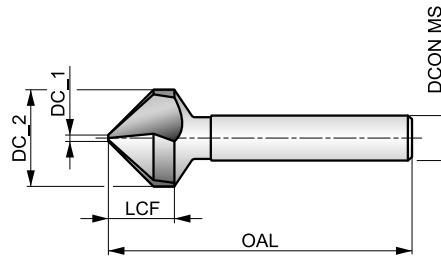

HSS-E	AlTiCN	DIN 335C
R	90°	

Adéquation du groupe de matériaux de la pièce, valeurs de départ pour la vitesse de coupe (m/min) et code Alpha d'avance. Les tableaux d'avances par tour se trouvent à partir de la page 251.

P1.1 ■ 40 E	P1.2 ■ 45 E	P1.3 ■ 46 E	P2.1 ■ 34 E	P2.2 ■ 30 D	P2.3 ■ 27 B	P3.1 ■ 28 D	P3.2 ■ 22 D	P3.3 ■ 19 B	P4.1 ■ 16 D	P4.2 ■ 14 B	P4.3 ■ 11 B	M1.1 ■ 23 C	M1.2 ■ 20 C
M2.1 ■ 21 C	M2.2 ■ 17 C	M2.3 ■ 14 A	M3.1 ■ 14 B	M3.2 ■ 12 B	M3.3 ■ 11 B	M4.1 ■ 15 A	M4.2 ■ 13 A	K1.1 ■ 41 C	K1.2 ■ 30 C	K1.3 ■ 23 C	K2.1 ■ 42 C	K2.2 ■ 34 C	K2.3 ■ 27 C
K3.1 ■ 37 C	K3.2 ■ 28 C	K3.3 ■ 23 C	K4.1 ■ 34 C	K4.2 ■ 26 C	K4.3 ■ 19 C	K5.1 ■ 39 C	K5.2 ■ 29 C	K5.3 ■ 23 C	N1.1 ■ 60 G	N1.2 ■ 45 G	N1.3 ■ 30 F	N2.1 ■ 30 F	N2.2 ■ 27 F
N2.3 ■ 19 F	N3.1 ■ 32 F	N3.2 ■ 18 F	N3.3 ■ 9 D										

DCON MS tolérance h9.

Produit	DC_2 (mm)	DC_1 (mm)	LCF (mm)	OAL (mm)	DCON MS (mm)	NOF
G5706.3	6.30	1.50	6.5	45.0	5.00	3
G5708.3	8.30	2.00	8.2	50.0	6.00	3
G57010.4	10.40	2.50	9.7	50.0	6.00	3
G57012.4	12.40	2.80	10.6	56.0	8.00	3
G57016.5	16.50	3.20	13.9	60.0	10.00	3
G57020.5	20.50	3.50	17.1	63.0	10.00	3
G57025.0	25.00	3.80	21.4	67.0	10.00	3
G57031.0	31.00	4.20	24.4	71.0	12.00	3



G107



Fraise en HSS-E à ébavurer et à chanfreiner à 90° à queue hexagonale, finition brillante

Fraise polyvalente avec une queue hexagonale qui facilite la prise en main avec les adaptateurs de tournevis électriques. La fraise à 90° produit des chanfreins pour les trous de fixation standards et élimine les bavures des trous percés. Convient pour chanfreiner les trous dans de nombreux matériaux.

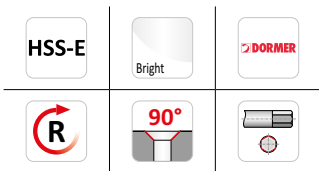
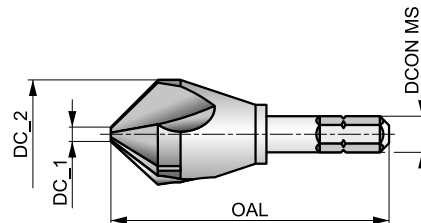

Adéquation du groupe de matériaux de la pièce, valeurs de départ pour la vitesse de coupe (m/min) et code Alpha d'avance. Les tableaux d'avances par tour se trouvent à partir de la page 251.

P1.1 ■ 23 E	P1.2 ■ 26 E	P1.3 ■ 27 E	P2.1 ■ 20 E	P2.2 ■ 18 D	P2.3 ▣ 16 B	P3.1 ■ 16 D	P3.2 ■ 13 D	P3.3 ▣ 11 B	P4.1 ■ 10 D	P4.2 ▣ 8 B	M1.1 ▣ 11 C	M1.2 ▣ 9 C	M2.1 ▣ 10 C
M2.2 ▣ 9 C	M2.3 ▣ 8 B	K1.1 ■ 20 F	K1.2 ▣ 15 D	K2.1 ■ 21 C	K2.2 ▣ 17 C	K3.1 ■ 18 C	K3.2 ▣ 14 C	K4.1 ▣ 15 C	K5.1 ■ 19 C	K5.2 ▣ 15 C	N1.1 ▣ 40 G	N1.2 ■ 30 G	N1.3 ▣ 20 F
N2.1 ▣ 20 F	N2.2 ▣ 18 F	N2.3 ▣ 20 F	N3.1 ■ 21 F	N3.2 ▣ 12 F	N3.3 ▣ 6 D	N4.1 ▣ 40 G	N4.2 ▣ 35 G						

Queue hex. 6.35; 1/4"; DIN 74.

Produit	DC_2	DC_1	OAL	DCONMS	CZC MS	NOF
	(mm)	(mm)	(mm)	(inch)		
G1076.3	6.30	1.50	50.0	1/4"	M2-M3	3
G1078.3	8.30	2.00	50.0	1/4"	M4	3
G10710.4	10.40	2.50	50.0	1/4"	M5	3
G10712.4	12.40	2.80	50.0	1/4"	M6	3
G10716.5	16.50	3.20	50.0	1/4"	M8	3
G10720.5	20.50	3.50	50.0	1/4"	M10	3



G600



Fraise en HSS à ébavurer et à chanfreiner à 90° extra-longue à queue cylindrique, finition brillante

Fraise à chanfreiner à 90° avec une queue longue permettant de chanfreiner les trous dans les zones difficiles à atteindre. Permet de réaliser des chanfreins à 90° dans des trous de fixation standards et de nettoyer les bavures des trous percés. Convient pour chanfreiner les trous dans de nombreux matériaux.

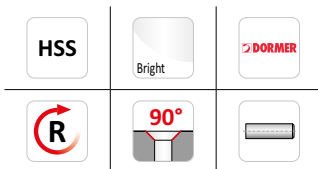
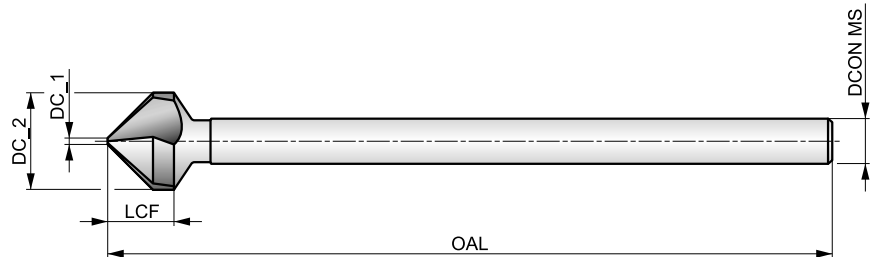

Adéquation du groupe de matériaux de la pièce, valeurs de départ pour la vitesse de coupe (m/min) et code Alpha d'avance. Les tableaux d'avances par tour se trouvent à partir de la page 251.

P1.1 ■ 20 E	P1.2 ■ 22 E	P1.3 ■ 23 E	P2.1 ■ 17 E	P2.2 ■ 15 D	P2.3 ■ 13 B	P3.1 ■ 12 D	P3.2 ■ 9 D	P3.3 ■ 8 B	P4.1 ■ 7 D	P4.2 ■ 6 B	M1.1 ■ 8 C	M1.2 ■ 6 C	M2.1 ■ 7 C
M2.2 ■ 16 C	K1.1 ■ 17 E	K1.2 ■ 12 C	K2.1 ■ 18 B	K2.2 ■ 14 B	K3.1 ■ 15 B	K3.2 ■ 11 B	K5.1 ■ 16 B	K5.2 ■ 12 B	N1.1 ■ 35 G	N1.2 ■ 25 G	N1.3 ■ 15 F	N2.1 ■ 15 F	N2.2 ■ 13 F
N3.1 ■ 16 E	N3.2 ■ 10 E	N3.3 ■ 5 C											

DCON MS tolérance h9.

Produit	DC_2 (mm)	DC_1 (mm)	LCF (mm)	OAL (mm)	DCON MS (mm)	NOF
G6006.3	6.30	1.30	5.6	154.0	5.00	3
G6008.3	8.30	1.80	6.9	155.0	6.00	3
G60010.4	10.40	2.20	7.8	157.0	6.00	3
G60012.4	12.40	2.50	8.6	158.0	8.00	3
G60015.0	15.00	2.80	10.3	159.0	10.00	3
G60016.5	16.50	2.80	11.1	161.0	10.00	3
G60020.5	20.50	3.00	12.9	164.0	10.00	3
G60025.0	25.00	3.20	15.7	168.0	10.00	3



G132



Fraise en HSS à ébavurer et à chanfreiner à 90° à queue cylindrique, multi-dents, finition brillante

Fraise à 90° conçue pour les trous de fixation standards et réaliser des opérations d'ébavurage. Le grand nombre de dents permet de réduire les vibrations pour une opération de chanfreinage en douceur. Fraise polyvalente adaptée aussi bien pour les applications électro-portatives que sur machines. Elle convient pour le chanfreinage de trous dans de nombreux matériaux.

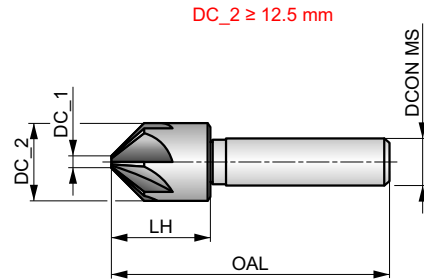
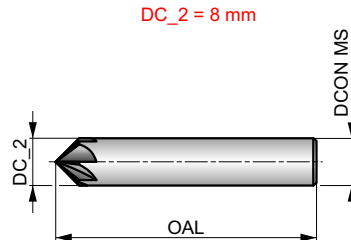

HSS	Bright	DIN 335A
R	90°	

Adéquation du groupe de matériaux de la pièce, valeurs de départ pour la vitesse de coupe (m/min) et code Alpha d'avance. Les tableaux d'avances par tour se trouvent à partir de la page 251.

P2.2 ▣ 18 E	P2.3 ▣ 16 D	P3.2 ▣ 13 D	P3.3 ▣ 11 B	P4.1 ▣ 10 D	P4.2 ▣ 8 C	P4.3 ▣ 7 B	M3.3 ▣ 3 A	M4.1 ▣ 4 A	K1.1 ▣ 20 F	K1.2 ▣ 15 D	K1.3 ▣ 11 D	K2.2 ▣ 17 C	K2.3 ▣ 14 D
K3.1 ▣ 18 E	K3.2 ▣ 14 E	K3.3 ▣ 11 D	K4.1 ▣ 17 C	K4.2 ▣ 13 C	K5.1 ▣ 19	K5.2 ▣ 15	K5.3 ▣ 11 D	N1.3 ▣ 20 F	N2.3 ▣ 13 F	N3.2 ▣ 12 F	N4.3 ▣ 5 G		

DCON MS tolérance h9.

Produit	DC_2 (mm)	DC_1 (mm)	LH (mm)	OAL (mm)	DCON MS (mm)	NOF
G1328.0	8.00	—	—	48.0	8.00	5
G13212.5	12.50	2.00	15.5	48.0	8.00	5
G13216.0	16.00	3.20	19.5	56.0	10.00	7
G13220.0	20.00	5.00	23.0	60.0	10.00	7



G138



Fraise en HSS à ébavurer et à chanfreiner à 90° à queue cône morse, finition brillante

Fraise à chanfreiner à 90° conçue pour les trous de fixation standards et réaliser des opérations d'ébavurage. Attachements en cône morse tailles de 2 à 4 pour une fixation directe dans la broche de la machine. Convient dans de très nombreux matériaux.

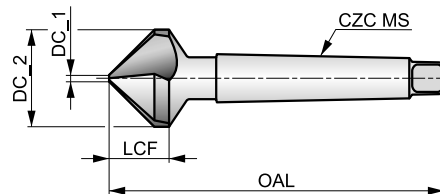

HSS	Bright	DIN 335D
R	90°	

Adéquation du groupe de matériaux de la pièce, valeurs de départ pour la vitesse de coupe (m/min) et code Alpha d'avance. Les tableaux d'avances par tour se trouvent à partir de la page 251.

P1.1 ■ 23 E	P1.2 ■ 26 E	P1.3 ■ 27 E	P2.1 ■ 20 E	P2.2 ■ 18 D	P2.3 ▧ 16 B	P3.1 ■ 16 D	P3.2 ▧ 13 D	P3.3 ▧ 11 B	P4.1 ■ 10 D	P4.2 ▧ 8 B	M1.1 ▧ 8	M1.2 ▧ 6	M2.1 ▧ 7
M2.2 ▧ 6	K1.1 ▧ 20 F	K1.2 ▧ 15 D	K2.1 ▧ 21 C	K2.2 ▧ 17 C	K3.1 ▧ 18 C	K3.2 ▧ 14 C	K5.1 ▧ 19 C	K5.2 ▧ 15 C	N1.1 ▧ 40 G	N1.2 ■ 30 G	N1.3 ▧ 20 F	N2.1 ■ 20 F	N2.2 ▧ 18 F
N3.1 ■ 21 F	N3.2 ■ 12 F	N3.3 ▧ 6 D	N4.1 ▧ 40 G	N4.2 ▧ 35 G									

Produit	DC_2 (mm)	DC_1 (mm)	LCF (mm)	OAL (mm)	CZC MS	NOF
G13825.0	25.00	3.80	15.5	106.0	MK 2	3
G13830.0	30.00	4.20	18.5	112.0	MK 2	3
G13831.0	31.00	4.20	20.0	112.0	MK 2	3
G13834.0	34.00	4.50	19.5	118.0	MK 2	3
G13837.0	37.00	4.80	21.7	118.0	MK 2	3
G13840.0	40.00	10.00	20.5	140.0	MK 3	3
G13850.0	50.00	14.00	24.1	150.0	MK 3	3
G13863.0	63.00	16.00	28.5	180.0	MK 4	3
G13880.0	80.00	22.00	36.0	190.0	MK 4	3



G338

DORMER



Fraise en HSS à ébavurer et à chanfreiner à 90° à queue cône morse, revêtement TiN

Fraise à chanfreiner à 90° conçue pour les trous de fixation standards et réaliser des opérations d'ébavurage. Attachements en cône morse tailles de 2 à 4 pour une fixation directe dans la broche de la machine. Son revêtement TiN améliore la performance et prolonge la durée de vie de l'outil dans des vitesses de coupe élevées. Convient pour chanfreiner dans de très nombreux matériaux.

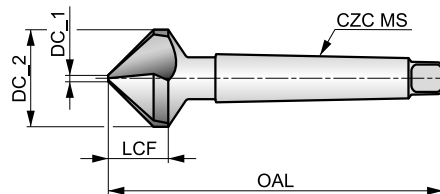

HSS	TiN	DIN 335D
R	90°	

Adéquation du groupe de matériaux de la pièce, valeurs de départ pour la vitesse de coupe (m/min) et code Alpha d'avance. Les tableaux d'avances par tour se trouvent à partir de la page 251.

P1.1 ■ 33 E	P1.2 ■ 37 E	P1.3 ■ 38 E	P2.1 ■ 28 E	P2.2 ■ 25 D	P2.3 ■ 22 B	P3.1 ■ 23 D	P3.2 ■ 18 D	P3.3 ■ 15 B	P4.1 ■ 13 D	P4.2 ■ 11 B	P4.3 ▣ 9 B	M1.1 ▣ 11 C	M1.2 ▣ 9 C
M2.1 ▣ 10 C	M2.2 ▣ 9 C	M2.3 ▣ 8 B	K1.1 ■ 34 F	K1.2 ■ 25 D	K1.3 ▣ 19 D	K2.1 ■ 35 C	K2.2 ■ 28 C	K2.3 ▣ 23 C	K3.1 ■ 31 C	K3.2 ■ 24 C	K3.3 ▣ 19 C	K4.1 ▣ 29 C	K4.2 ▣ 22 C
K4.3 ▣ 16 C	K5.1 ■ 32 C	K5.2 ■ 24 C	K5.3 ▣ 19 C	N1.1 ■ 53 G	N1.2 ■ 40 G	N1.3 ■ 27 F	N2.1 ■ 27 F	N2.2 ■ 24 F	N2.3 ■ 17 F	N3.1 ■ 28 F	N3.2 ■ 16 F	N3.3 ▣ 8 D	N4.1 ▣ 58 G
N4.2 ▣ 50 G													

Produit	DC_2 (mm)	DC_1 (mm)	LCF (mm)	OAL (mm)	CZC MS	NOF
G33825.0	25.00	3.80	15.5	106.0	MK 2	3
G33831.0	31.00	4.20	20.0	112.0	MK 2	3
G33837.0	37.00	4.80	21.7	118.0	MK 2	3
G33840.0	40.00	10.00	20.5	140.0	MK 3	3
G33850.0	50.00	14.00	24.1	150.0	MK 3	3
G33863.0	63.00	16.00	28.5	180.0	MK 4	3



G171



Fraise en HSS à ébavurer et à chanfreiner à 100° à queue cylindrique

Fraise à chanfreiner à 100° conçue pour les trous de fixation standards et les opérations d'ébavurage. Outil polyvalent avec un revêtement TiAlN qui améliore les performances et prolonge la durée de vie de l'outil dans la plupart des matériaux. Elle peut être utilisée aussi bien pour les applications électro-portatives que sur machines.

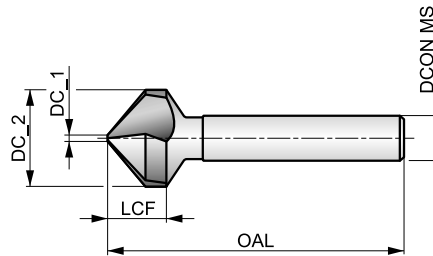

Adéquation du groupe de matériaux de la pièce, valeurs de départ pour la vitesse de coupe (m/min) et code Alpha d'avance. Les tableaux d'avances par tour se trouvent à partir de la page 251.

P1.1 ■ 40 E	P1.2 ■ 45 E	P1.3 ■ 46 E	P2.1 ■ 34 E	P2.2 ■ 30 D	P2.3 ■ 27 B	P3.1 ■ 28 D	P3.2 ■ 22 D	P3.3 ■ 19 B	P4.1 ■ 16 D	P4.2 ■ 14 B	P4.3 ▣ 11 B	M1.1 ▣ 11 C	M1.2 ▣ 9 C
M2.1 ▣ 10 C	K1.1 ■ 41 F	K1.2 ■ 30 D	K1.3 ▣ 23 D	K2.1 ■ 42 C	K2.2 ■ 34 C	K2.3 ▣ 27 C	K3.1 ■ 37 C	K3.2 ■ 28 C	K3.3 ▣ 23 C	K4.1 ▣ 34 C	K4.2 ▣ 26 C	K4.3 ▣ 19 C	K5.1 ■ 39 C
K5.2 ■ 29 C	K5.3 ▣ 23 C	N1.1 ▣ 60 G	N1.2 ▣ 45 G	N1.3 ■ 30 F	N2.1 ■ 30 F	N2.2 ■ 27 F	N2.3 ■ 19 F	N3.1 ■ 32 F	N3.2 ■ 18 F	N3.3 ▣ 9 D	N4.1 ▣ 62 G	N4.2 ▣ 55 G	

DCON MS tolérance h9.

Produit	DC_2 (mm)	DC_1 (mm)	LCF (mm)	OAL (mm)	DCON MS (mm)	NOF
G1716.3	6.30	1.50	4.5	44.0	5.00	3
G1718.3	8.30	2.00	5.5	49.0	6.00	3
G17110.4	10.40	2.50	6.6	49.0	6.00	3
G17112.4	12.40	2.80	7.0	53.0	8.00	3
G17116.5	16.50	3.20	9.0	56.0	10.00	3
G17120.5	20.50	3.50	11.0	61.0	10.00	3
G17125.0	25.00	3.80	13.5	65.0	10.00	3



G314



Foret étagé conique en HSS à coupe pour matériaux en feuilles minces, finition brillante

Forets étagé à coupe conique ayant plusieurs diamètres qui permettent d'agrandir progressivement les trous jusqu'au diamètre requis. La queue cylindrique réduite permet de maintenir tous les diamètres dans un mandrin et un support standard. Convient pour agrandir les trous dans de nombreux matériaux.

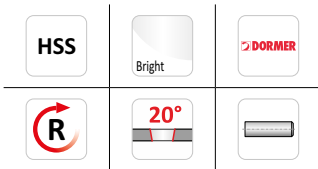
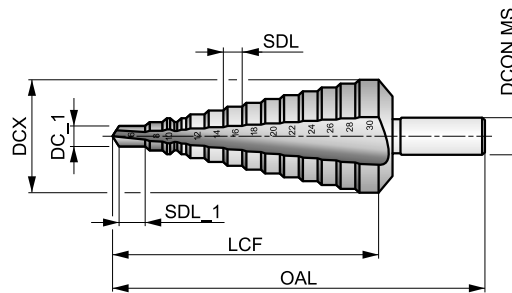

Adéquation du groupe de matériaux de la pièce, valeurs de départ pour la vitesse de coupe (m/min) et code Alpha d'avance. Les tableaux d'avances par tour se trouvent à partir de la page 251.

P1.1 ■ 20	P1.2 ■ 22	P1.3 ■ 23	P2.1 ■ 17	P2.2 ■ 15	P2.3 ■ 13	P3.1 ■ 12	P3.2 ■ 9	M1.1 ■ 8	M1.2 ■ 6	M2.1 ■ 7	K1.1 ■ 17	N1.1 ■ 30	N1.2 ■ 23
N1.3 ■ 15	N2.1 ■ 31	N2.2 ■ 28	N3.1 ■ 34	N3.2 ■ 20	N3.3 ■ 10	N4.1 ■ 30	N4.2 ■ 20						

SDI = dimensions de chaque diamètre incrémenté.

Produit	Nr.	DC_1	DCX	SDL	SDI	SDL_1	LCF	OAL	DCON MS
		(mm)	(mm)	(mm)	(mm)	(mm)	(mm)	(mm)	(mm)
G314412	412	4.00	12.00	5.00	4 - 5 - 6 - 7 - 8 - 9 - 10 - 11 - 12	5.00	61.0	80.0	6.00
G3141220	1220	12.00	20.00	4.00	12 - 13 - 14 - 15 - 16 - 17 - 18 - 19 - 20	4.00	55.0	76.0	9.00
G3142030	2030	20.00	30.00	4.00	20 - 21 - 22 - 23 - 24 - 25 - 26 - 27 - 28 - 29 - 30	4.00	67.0	88.0	12.00
G3143040	3040	30.00	40.00	4.00	30 - 31 - 32 - 33 - 34 - 35 - 36 - 37 - 38 - 39 - 40	4.00	74.0	98.0	13.00
G314420	420	4.00	20.00	4.00	4 - 6 - 8 - 10 - 12 - 14 - 16 - 18 - 20	4.00	48.0	76.0	8.00
G314630	630	6.00	30.00	4.00	6 - 8 - 10 - 12 - 14 - 16 - 18 - 20 - 22 - 24 - 26 - 28 - 30	4.00	73.0	98.0	10.00
G314M	M	9.00	36.00	3.00	9 - 12 - 15 - 18 - 21 - 24 - 27 - 30 - 33 - 36	3.00	57.0	86.0	12.00



G125



Fraise à lamer en HSS à 180° à queue cylindrique, finition brillante

Fraise à lamer avec un angle de 180° conçue pour créer les logements de vis à tête creuse et à tête cylindrique CHC standard. Elle est dotée d'un pilote solide (disponible pour différentes tolérances de taille de trou pré-usiné), qui aide à guider la fraise avec précision dans les trous de tailles métriques standards. Convient pour les lamages de trous dans de nombreux matériaux.

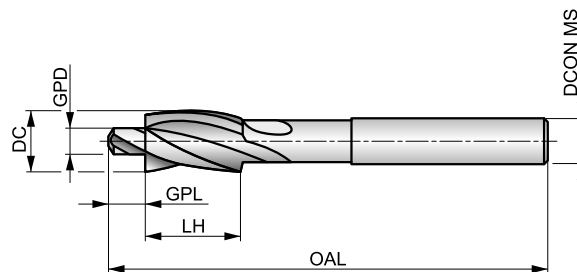

HSS	Bright	DIN 373
R	180°	

Adéquation du groupe de matériaux de la pièce, valeurs de départ pour la vitesse de coupe (m/min) et code Alpha d'avance. Les tableaux d'avances par tour se trouvent à partir de la page 251.

P1.1 ■ 20 E	P1.2 ■ 22 E	P1.3 ■ 23 E	P2.1 ■ 17 E	P2.2 ■ 15 D	P2.3 ■ 13 C	P3.1 ■ 12 D	P3.2 ■ 9 D	P3.3 ■ 8 C	P4.1 ■ 7 D	P4.2 ■ 6 C	M1.1 ■ 8 D	M1.2 ■ 6 D	M2.1 ■ 7 D
M2.2 ■ 6 D	M2.3 ■ 5 C	K1.1 ■ 17 E	K1.2 ■ 12 E	K1.3 ■ 11 E	K2.1 ■ 15 D	K2.2 ■ 12 D	K2.3 ■ 10 C	K3.1 ■ 13 D	K3.2 ■ 10 D	K4.1 ■ 12 D	K4.2 ■ 9 D	K5.1 ■ 14 D	K5.2 ■ 10 D
N1.1 ■ 30 G	N1.2 ■ 23 G	N1.3 ■ 15 G	N2.1 ■ 31 G	N2.2 ■ 28 G	N2.3 ■ 20 G	N3.1 ■ 34 C	N3.2 ■ 20 C	N3.3 ■ 10 C	N4.1 ■ 30 C	N4.2 ■ 20 C			

DCON MS tolérance h9.

Produit	DC (mm)	GPD (mm)	CZC MS	GPL (mm)	OAL (mm)	LH (mm)	DCON MS (mm)	NOF
G1256.5X2.5 ³⁾	6.50	2.50	M 3 t	4.50	71.0	14.0	5.00	3
G1256.5X3.2 ¹⁾	6.50	3.20	M 3 f	4.50	71.0	14.0	5.00	3
G1256.5X3.4 ²⁾	6.50	3.40	M 3 m	4.50	71.0	14.0	5.00	3
G1258.0X3.3 ³⁾	8.00	3.30	M 4 t	5.00	71.0	14.0	5.00	3
G1258.0X4.3 ¹⁾	8.00	4.30	M 4 f	5.00	71.0	14.0	5.00	3
G1258.0X4.5 ²⁾	8.00	4.50	M 4 m	5.00	71.0	14.0	5.00	3
G12510.0X4.2 ³⁾	10.00	4.20	M 5 t	5.50	80.0	18.0	8.00	3
G12510.0X5.3 ¹⁾	10.00	5.30	M 5 f	5.50	80.0	18.0	8.00	3
G12510.0X5.5 ²⁾	10.00	5.50	M 5 m	5.50	80.0	18.0	8.00	3
G12511.0X5.0 ³⁾	11.00	5.00	M 6 t	6.00	80.0	18.0	8.00	3
G12511.0X6.4 ¹⁾	11.00	6.40	M 6 f	6.00	80.0	18.0	8.00	3
G12511.0X6.6 ²⁾	11.00	6.60	M 6 m	6.00	80.0	18.0	8.00	3
G12515.0X6.8 ³⁾	15.00	6.80	M 8 t	8.00	100.0	22.0	12.50	3
G12515.0X8.4 ¹⁾	15.00	8.40	M 8 f	8.00	100.0	22.0	12.50	3
G12515.0X9.0 ²⁾	15.00	9.00	M 8 m	8.00	100.0	22.0	12.50	3
G12518.0X8.5 ³⁾	18.00	8.50	M 10 t	10.00	100.0	22.0	12.50	3
G12518.0X10.5 ¹⁾	18.00	10.50	M 10 f	10.00	100.0	22.0	12.50	3
G12518.0X11.0 ²⁾	18.00	11.00	M 10 m	10.00	100.0	22.0	12.50	3
G12520.0X10.2 ³⁾	20.00	10.20	M 12 t	10.00	100.0	22.0	12.50	3
G12520.0X13.0 ¹⁾	20.00	13.00	M 12 f	10.00	100.0	22.0	12.50	3
G12520.0X13.5 ²⁾	20.00	13.50	M 12 m	10.00	100.0	22.0	12.50	3

¹⁾ f= pour trou de vis débouchant précis.

²⁾ m= pour trou de vis débouchant moyen.

³⁾ t= pour trou taraudé.



G236

DORMER



Coffret de fraises à éburer et à chanfreiner dans un boîtier cylindrique en plastique

Coffrets contenant une variété de différentes tailles de fraises à chanfreiner à 90°. Il existe 5 jeux différents disponibles remplis soit de G106, G136 ou G560. Convient pour de nombreux matériaux.

A=Types dans le coffret, B=Quantité dans le coffret, C=Diamètres dans le coffret.

Produit	Nr.	A	B	C
G2361	1	G136	6	6.30 mm, 8.30 mm, 10.40 mm, 12.40 mm, 16.50 mm, 20.50 mm
G2362	2	G136	4	6.30 mm, 10.40 mm, 16.50 mm, 20.50 mm
G2363	3	G560	6	6.30 mm, 8.30 mm, 10.40 mm, 12.40 mm, 16.50 mm, 20.50 mm
G2364	4	G106	6	6.30 mm, 8.30 mm, 10.40 mm, 12.40 mm, 16.50 mm, 20.50 mm
G2365	5	G506	6	6.30 mm, 8.30 mm, 10.40 mm, 12.40 mm, 16.50 mm, 20.50 mm



TABLEAU DES AVANCES POUR LES ALÉSOIRS

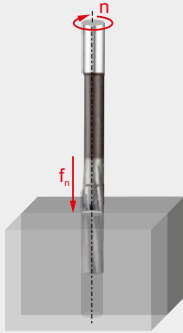

Avance par tour (f_n en mm/tr)
Ajuster ces valeurs de $\pm 15\%$ selon les conditions de travail.

Comment trouver l'avance par tour (f_n) grâce à ce tableau :

1. Rechercher le code Alpha sur la page produit (par ex. 21C, « C » étant le code Alpha).
2. Trouver le diamètre le plus proche de celui recherché pour votre application (première ligne du tableau).
3. Rechercher votre code Alpha dans la colonne gauche du tableau.
4. La cellule à l'intersection de la colonne Diamètre et de la ligne code Alpha indique l'avance par tour (f_n).

		ø DC (mm)																		
		1.00	1.50	2.00	3.00	4.00	5.00	6.00	7.00	8.00	10.00	12.00	15.00	16.00	20.00	25.00	30.00	40.00	50.00	80.00
Avances	A	0.030	0.045	0.055	0.078	0.090	0.100	0.125	0.137	0.150	0.170	0.185	0.210	0.220	0.250	0.280	0.320	0.390	0.440	0.500
	B	0.035	0.055	0.072	0.110	0.130	0.150	0.165	0.172	0.180	0.210	0.240	0.270	0.280	0.310	0.360	0.400	0.500	0.550	0.600
	C	0.040	0.065	0.085	0.135	0.160	0.185	0.200	0.210	0.220	0.260	0.285	0.325	0.335	0.390	0.440	0.480	0.600	0.680	0.750
	D	0.050	0.080	0.110	0.160	0.180	0.200	0.235	0.253	0.270	0.320	0.360	0.400	0.410	0.470	0.540	0.600	0.730	0.850	0.950
	E	0.065	0.100	0.140	0.180	0.215	0.250	0.300	0.325	0.350	0.390	0.430	0.485	0.500	0.530	0.640	0.750	0.910	1.100	1.200
	F	0.090	0.140	0.180	0.260	0.305	0.350	0.395	0.417	0.440	0.500	0.550	0.610	0.630	0.700	0.800	0.930	1.200	1.500	1.650

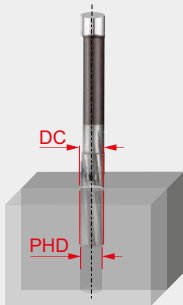

Tolérance d'usinage avec un **alésoir machine** (MA en mm)
Diamètre de préperçage
 $PHD = DC - MA$

Comment trouver le bon diamètre de préperçage (PHD) avec ce tableau :

1. Trouver la plage de diamètres la plus proche de celui recherché pour votre application (première ligne du tableau).
2. Rechercher votre code de groupe ISO dans la colonne gauche du tableau. Par ex. : le code de groupe ISO de l'acier inoxydable est « M ».
3. La cellule à l'intersection de la colonne Plage de Diamètre et de la ligne code de groupe ISO indique la tolérance d'usinage (MA).
4. Soustraire la tolérance d'usinage au diamètre d'alésage pour obtenir le diamètre de préperçage (PHD).

(Exemple : pour un trou de 6 mm dans l'acier (P), le $PHD = 5,85$ mm)

		ø DC (mm)										
		1.00	5.00	5.00	8.00	8.00	12.00	12.00	16.00	16.00	30.00	30.00
Groupe ISO	P	0.10		0.15		0.20		0.20		0.30		0.30
	M	0.08		0.10		0.10		0.20		0.20		0.30
	K	0.10		0.15		0.20		0.20		0.30		0.30
	N	0.10		0.15		0.20		0.20		0.30		0.30
	S	0.05		0.10		0.10		0.15		0.20		0.20
	H	0.05		0.05		0.10		0.10		0.15		0.20

Attention avec les tolérances d'usinage des forets : le diamètre de l'outil ne correspond pas au diamètre percé !

Remarque : la tolérance recommandée avec un alésoir à main se situe entre 0,05 et 0,10 mm.



TABLEAU DES AVANCES POUR LES FRAISES À CHANFREINER

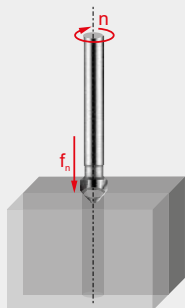

Avance par tour (f_n en mm/tr)
Ajuster ces valeurs de $\pm 15\%$ selon les conditions de travail.

Comment trouver l'avance par tour (f_n) grâce à ce tableau :

1. Rechercher le code Alpha sur la page produit (par ex. 23E, « E » étant le code Alpha).
2. Trouver le diamètre le plus proche de celui recherché pour votre application (première ligne du tableau).
3. Rechercher votre code Alpha dans la colonne gauche du tableau.
4. La cellule à l'intersection de la colonne Diamètre et de la ligne code Alpha indique l'avance par tour (f_n).

	ø DC (mm)										
	6.00	8.00	10.00	16.00	20.00	25.00	32.00	40.00	60.00	80.00	
Avances	A	0.030	0.040	0.050	0.060	0.080	0.090	0.100	0.120	0.140	0.160
	B	0.040	0.050	0.060	0.080	0.100	0.120	0.140	0.160	0.180	0.200
	C	0.050	0.060	0.080	0.100	0.120	0.140	0.160	0.180	0.200	0.220
	D	0.060	0.080	0.100	0.120	0.150	0.180	0.200	0.220	0.250	0.280
	E	0.080	0.100	0.120	0.150	0.180	0.200	0.250	0.270	0.300	0.320
	F	0.090	0.110	0.130	0.160	0.190	0.210	0.260	0.290	0.330	0.360
	G	0.100	0.120	0.150	0.180	0.200	0.220	0.280	0.320	0.360	0.400
	H	0.120	0.150	0.180	0.200	0.220	0.250	0.300	0.350	0.400	0.450

Alésoirs : définitions et nomenclature

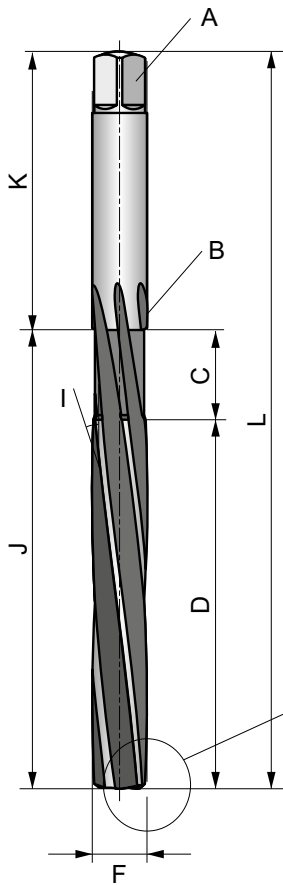

A	Tenon ou carré d'entraînement
B	Diamètre du détalonnage
C	Longueur du détalonnage
D	Longueur de coupe
E	Longueur du chanfrein d'entrée
F	Diamètre

G	Chanfrein d'entrée
H	Angle du chanfrein d'entrée
I	Angle d'hélice
J	Longueur de corps
K	Longueur queue
L	Longueur totale

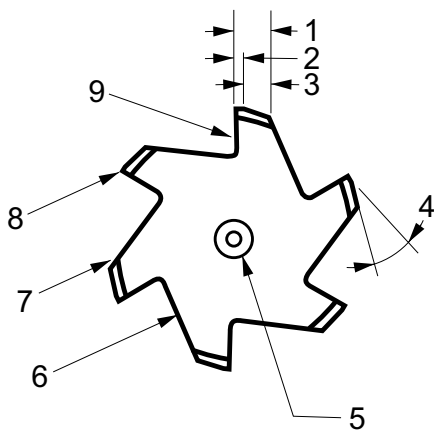
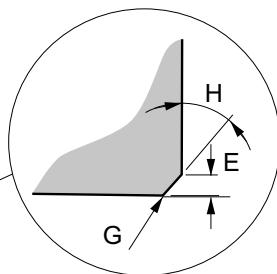

1	Largeur de listel
2	Dépouille cylindrique
3	Dépouille
4	Angle de dépouille
5	Trou de centre
6	Goujure
7	Listel
8	Arête de coupe
9	Face

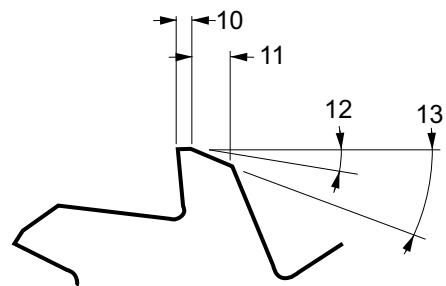

10	Largeur de dépouille primaire
11	Largeur de dépouille secondaire
12	Angle de dépouille primaire
13	Angle de dépouille secondaire



ALÉSOIRS – INFORMATIONS TECHNIQUES

Alesage

Pour obtenir les meilleurs résultats avec les alésoirs, il est important de les faire « travailler ». On fait souvent l'erreur de préparer les trous à aléser en y laissant une surépaisseur insuffisante. Si on ne laisse pas assez de surépaisseur dans le trou à aléser, le frottement entraîne une usure rapide de l'alésoir, avec pour conséquence une perte de diamètre. Pour de bons résultats, il est tout aussi important que la surépaisseur ne soit pas excessive. (Voir la section Enlèvement de matière ci-dessous).

1. Sélectionner le type d'alésoir le plus adapté ainsi que les conditions de vitesse de coupe et d'avance optimales pour l'application. Vérifiez que les trous percés ont un diamètre correct.
2. La pièce doit être maintenue de manière rigide et la broche de la machine ne doit pas avoir de jeu.
3. Le mandrin utilisé pour monter un alésoir à queue cylindrique doit être de bonne qualité. Si l'alésoir glisse dans le mandrin et si l'avance est automatique, l'alésoir risque de se casser.
4. Réduisez au minimum le porte-à-faux de l'outil par rapport à l'axe de la machine.

5. Utilisez les lubrifiants recommandés pour prolonger la durée de vie de l'alésoir et veillez à ce que le fluide atteigne toute les arêtes de coupe. Comme l'alésage n'est pas une opération de coupe difficile, une dilution 40:1 d'huile soluble convient généralement. De l'air comprimé peut être utilisé pour l'alésage à sec de la fonte grise.
6. Evitez le bourrage des copeaux dans les goujures d'un alésoir.
7. Avant d'affûter l'alésoir, vérifiez sa concentricité entre pointes. Dans la plupart des cas, seul le chanfrein d'entrée a besoin d'être réaffûté.
8. Veillez à ce que les alésoirs soient toujours bien affûtés. Un affûtage fréquent se justifie d'un point de vue économique, mais il ne faut pas oublier que les alésoirs ne coupent que sur le chanfrein et le cône d'entrée et non pas sur les listels de guidage. Par conséquent, seuls le chanfrein et le cône d'entrée doivent être réaffûtés. La précision de l'affûtage est importante tant pour la qualité du trou que pour la durée de vie de l'outil.

Enlèvement de surepaisseur

L'enlèvement de surépaisseur recommandé en alésage dépend du matériau de l'application et de la finition de surface du trou à aléser. Les recommandations de surépaisseur à enlever sont décrites dans les tableaux ci-dessous :

Diamètre du trou alésé (mm)	Sur avant trou au foret	Sur avant trou au foret alésoir
En dessous de 3/16	0.1	0.1
De 4 à 11	0.2	0.15
De 11 à 39	0.3	0.2
De 39 à 50	0.4	0.3

Diamètre du trou alésé (pouce)	Sur avant trou au foret	Sur avant trou au foret alésoir
En dessous de 3/16	0.004"	0.004"
3/16" à 1/2"	0.008"	0.006"
1/2" à 1,1/2"	0.010"	0.008"
1,1/2" à 2"	0.016"	0.010"

ALÉSAGE MANUEL / MACHINE

Bien que les alésoirs à main et les alésoirs machine offrent les mêmes possibilités en matière de dimensions de trou, le choix de l'un ou l'autre dépend de l'application. Un alésoir à main, pour une question d'alignement, a un long pas conique, alors qu'un alésoir machine n'a qu'un pas biseauté à 45 degrés. Un alésoir machine ne coupe que sur le biseau principal, tandis qu'un alésoir à main coupe sur le biseau principal et le cône d'entrée.



ALÉSOIRS – LIMITES DE TOLÉRANCE – INFORMATIONS TECHNIQUES

Ecart de tolérance

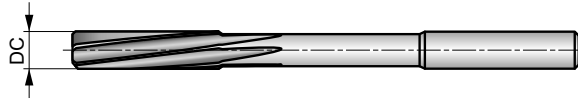

1. Sur le diamètre de coupe d'alesoirs standard

Le diamètre se mesure sur le listel de guidage juste derrière le chanfrein ou le cône d'entrée. La tolérance selon la DIN 1420 est destinée à produire des alésages H7.

Tolérance de l'alesoir			
Diamètre (mm)		Ecart de tolérance (mm)	
Supérieur	Jusqu'à et y compris	Elevé +	Faible +
–	3	0.008	0.004
3	6	0.010	0.005
6	10	0.012	0.006
10	18	0.015	0.008

Tolérance de l'alesoir			
Diamètre (mm)		Ecart de tolérance (mm)	
Supérieur	Jusqu'à et y compris	Elevé +	Faible +
18	30	0.017	0.009
30	50	0.021	0.012
50	80	0.025	0.014

2. Sur un alésage H7

La tolérance la plus commune pour un trou fini est H7 (voir le tableau ci-dessous). Pour toute autre tolérance les données en dessous du point 3 peuvent être utilisées pour la calculer.

Tolérance du trou			
Diamètre (mm)		Ecart de tolérance (mm)	
Supérieur	Jusqu'à et y compris	Elevé +	Faible +
–	3	0.010	0
3	6	0.012	0
6	10	0.015	0
10	18	0.018	0

Tolérance du trou			
Diamètre (mm)		Ecart de tolérance (mm)	
Supérieur	Jusqu'à et y compris	Elevé +	Faible +
18	30	0.021	0
30	50	0.025	0
50	80	0.030	0

3. Lorsqu'il est nécessaire de définir les dimensions d'un alésoir spécial destiné à produire une tolérance spécifique, par ex. D8, utilisez la formule suivante :

Amplitude de tolérance du diamètre (µm)								
Amplitude de tolérance (microns)	de 1 à 3	de 3 à 6	de 6 à 10	de 10 à 18	de 18 à 30	de 30 à 50	de 50 à 80	de 80 à 120
IT5	4	5	6	8	9	11	13	15
IT6	6	8	9	11	13	16	19	22
IT7	10	12	15	18	21	25	30	35
IT8	14	18	22	27	33	39	46	54
IT9	25	30	36	43	52	62	74	87
IT10	40	48	58	70	84	100	120	140
IT11	60	75	90	110	130	160	190	220
IT12	100	120	150	180	210	250	300	350

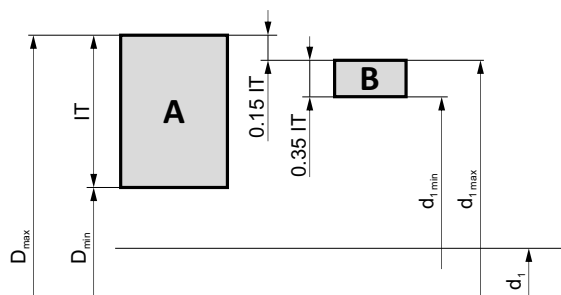

- A** = Tolérance du Trou
- B** = Tolérance de l'alesoir
- IT** = Amplitude de tolérance
- D_{max} = Diamètre de trou max
- D_{min} = Diamètre de trou min
- d_1 = Diamètre nominal
- d_{1max} = Diamètre max de l'alesoir
- d_{1min} = Diamètre min de l'alesoir

par ex. trou de 10 mm avec une tolérance D8, diam. max. = 10,062, diam. min. = 10,040, tol. alésage (IT8) = 0,022

Diamètre maximal : $0,15 \times$ tolérance de l'alésage (IT8) = 0,0033, soit = 0,004

Diamètre minimal : $0,35 \times$ tolérance de l'alésage (IT8) = 0,0077, soit = 0,008

Diamètre maximal de l'alesoir = $10,062 - 0,004 = 10,058$

Diamètre minimal de l'alesoir = $10,058 - 0,008 = 10,050$

Applications – Choix d'un alésoir

Les alésoirs les plus courants sont dotés d'une hélice à gauche car ils sont principalement utilisés pour réaliser des trous débouchants, donc en poussant les copeaux vers l'avant. Pour les trous borgnes, des alésoirs avec goujures droites ou hélice à droite sont recommandés. L'efficacité doit être calculée en fonction des conditions d'alésage : application, matériau, qualité du trou requis, enlèvement de matière, lubrification, etc. Un guide général des vitesses de coupe et d'avance pour les alésoirs machine est donné dans les tableaux d'avance et des

Groupes de matériaux à usiner WMG (voir le catalogue Dormer ou le configurateur de produits) et les tableaux d'enlèvement de matière. Avec une répartition très inégale des goujures, la division des dents n'est jamais la même. Comme aucune des dents n'est diamétralement opposée à une autre, l'alésoir produit un trou avec une variation réduite de la cylindricité comprise entre 1 et 2 μm . À titre de comparaison, cette variation de cylindricité peut aller jusqu'à 10 μm avec une répartition inégale conventionnelle.

Alésoirs au carbure – Comparaison répartition / répartition UE

répartition inégale
erreur de cylindricité jusqu'à 10 μm

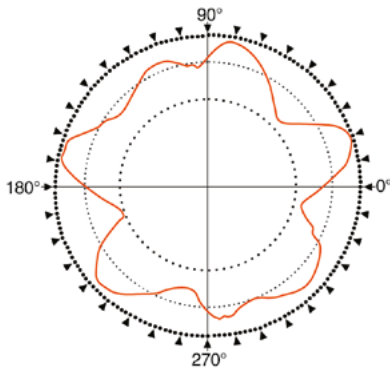

Résultats de cylindricité

répartition très inégale
erreur de cylindricité jusqu'à 1-2 μm

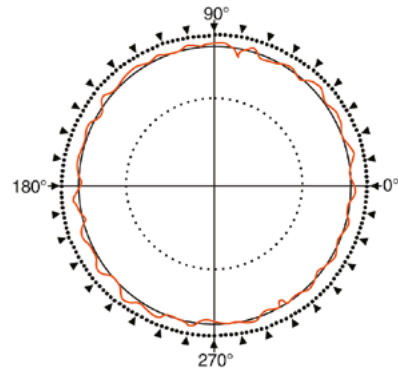

Résultats de cylindricité



ALÉSOIRS – RECOMMANDATIONS GÉNÉRALES – INFORMATIONS TECHNIQUES

Interruptions lors de l'alesage

Problème	Cause	Remède
Tenon cassé ou tordu	Mauvais contact entre la pince et la queue	S'assurer du bon état de la queue et de la douille
Usure rapide de l'outil	Enlèvement de matière insuffisant	Accroître l'enlèvement de matière
Trou surdimensionné	Variation excessive de la hauteur de lèvre	Réaffûter selon les spécifications correctes
	Jeu dans la broche de la machine	Réparer et rectifier l'axe
	Défaut du porte-outil	Remplacer le porte-outil
	Queue de l'outil endommagée	Remplacer ou réaffûter la queue
	Ovalisation de l'outil	Remplacer ou rectifier l'outil
	Angle de chanfrein d'entrée asymétrique	Réaffûter selon les spécifications correctes
	Avance ou vitesse de coupe trop élevées	Ajuster les conditions de coupe selon le catalogue
Trou sous dimensionné	Enlèvement de matière insuffisant	Accroître l'enlèvement de matière
	Trop de chaleur dégagée lors de l'alesage. Le trou s'élargit et se rétrécit	Accroître le flux d'huile
	Le diamètre de l'outil est détérioré et sous-dimensionné	Réaffûter selon les spécifications correctes
	Avance et vitesse de coupe trop faibles	Ajuster les conditions de coupe selon le catalogue
	Le trou de pré perçage est trop petit	Diminuer l'enlèvement de matière
Trous ovales et coniques	Jeu dans la broche de la machine	Réparer et rectifier l'axe
	Mauvais alignement entre l'outil et le trou	Utiliser un alésoir avec pilote
	Angle de chanfrein d'entrée asymétrique	Réaffûter selon les spécifications correctes
Mauvaise finition de trou	Enlèvement de surépaisseur excessif	Diminuer l'enlèvement de matière
	Détérioration de l'outil	Réaffûter selon les spécifications correctes
	Angle de coupe trop faible	Réaffûter selon les spécifications correctes
	Huile de coupe ou émulsion trop diluée	Accroître le % de concentration
	Avance et/ou vitesse trop faibles	Ajuster les conditions de coupe selon le catalogue
	Vitesse de coupe trop élevée	Ajuster les conditions de coupe selon le catalogue
L'outil se bloque et casse	Détérioration de l'outil	Réaffûter selon les spécifications correctes
	La conicité arrière de l'outil est trop faible	Vérifier et remplacer / modifier l'outil
	Une dépouille trop grande	Vérifier et remplacer / modifier l'outil
	Le matériau de la pièce usinée a tendance à se resserrer	Utiliser un alésoir réglable pour compenser le jeu
	Le trou de pré perçage est trop petit	Diminuer l'enlèvement de matière
	Matériau hétérogène avec inclusions dures	Utiliser un alésoir en carbure monobloc



INFORMATIONS TECHNIQUES GÉNÉRALES

	Nuance	Dureté (HV10)	C %	W %	Mo %	Cr %	V %	Co %	Matériau de l'outil
	M2	810 – 850	0.9	6.4	5.0	4.2	1.8	–	HSS
	M35	830 – 870	0.93	6.4	5.0	4.2	1.8	4.8	HSCO
	M42	870 – 960	1.08	1.5	9.4	3.9	1.2	8.0	

Propriétés	Aciers rapides (HSS)	Carbures	K10/30F (pour outils monoblocs généralement)
Dureté (HV30)	800-950	1300 – 1800	1600
Densité (g/cm ³)	8.0 – 9.0	7.2 – 15	14.45
Résistance à la compression (N/mm ²)	3000 – 4000	3000 – 8000	6250
Résistance à la flexion (N/mm ²)	2500 – 4000	1000 – 4700	4300
Résistance thermique (°C)	550	1000	900
Module de cisaillement (KN/mm ²)	260 – 300	460 – 630	580
Taille de grain (µm)	–	0.2 – 10	0.8

La combinaison de particules dures (WC) et d'un métal liant (Co) fait évoluer les caractéristiques comme suit :

Caractéristique	Teneur supérieure en WC	Teneur supérieure en Co
Dureté	Dureté supérieure	Dureté inférieure
Résistance à la compression (CS)	CS supérieure	CS inférieure
Résistance à la flexion (BS)	BS inférieure	BS supérieure

La taille de grain a également une influence sur les propriétés du matériau. Plus la taille est réduite, plus la dureté augmente ; la ténacité augmente avec la taille du grain.

Exemples de propriétés de revêtement et traitement de surface

Traitements de surface	Couleur	Matériau de revêtement	Dureté (HV)	Épaisseur (µm)	Structure du revêtement	Coef. frott. contre acier	Temp. max. appli. (°C)
	Doré	TiN	2300	1-4	Monocouche	0.4	600
	Gris noir	TiAlN	3300	3	Nanostructure	0.3-0.35	900



INFORMATIONS TECHNIQUES GÉNÉRALES

Tolérances standard pour les arbres et trous

Valeurs de tolérance exprimées en microns (μm)

Formule ...1 μm = 0,001 mm / 0,000039" pouce

Tolérance	Diamètre (mm)							
	> 1 ≤ 3	> 3 ≤ 6	> 6 ≤ 10	> 10 ≤ 18	> 18 ≤ 30	> 30 ≤ 50	> 50 ≤ 80	> 80 ≤ 120
	Diamètre (pouces)							
	> 0.039" ≤ 0.118"	> 0.118" ≤ 0.236"	> 0.236" ≤ 0.394"	> 0.394" ≤ 0.709"	> 0.709" ≤ 1.181"	> 1.181" ≤ 1.968"	> 1.968" ≤ 3.149"	> 3.149" ≤ 4.724"
Valeurs de tolérance (μm)								
e8	-14 / -28	-20 / -38	-25 / -47	-32 / -59	-40 / -73	-50 / -89	-60 / -106	-72 / -126
f6	-6 / -12	-10 / -18	-13 / -22	-16 / -27	-20 / -33	-25 / -41	-30 / -49	-36 / -58
f7	-6 / -16	-10 / -22	-13 / -28	-16 / -34	-20 / -41	-25 / -50	-30 / -60	-36 / -71
h6	0 / -6	0 / -8	0 / -9	0 / -11	0 / -13	0 / -16	0 / -19	0 / -22
h7	0 / -10	0 / -12	0 / -15	0 / -18	0 / -21	0 / -25	0 / -30	0 / -35
h8	0 / -14	0 / -18	0 / -22	0 / -27	0 / -33	0 / -39	0 / -46	0 / -54
h9	0 / -25	0 / -30	0 / -36	0 / -43	0 / -52	0 / -62	0 / -74	0 / -87
h10	0 / -40	0 / -48	0 / -58	0 / -70	0 / -84	0 / -100	0 / -120	0 / -140
h11	0 / -60	0 / -75	0 / -90	0 / -110	0 / -130	0 / -160	0 / -190	0 / -220
h12	0 / -100	0 / -120	0 / -150	0 / -180	0 / -210	0 / -250	0 / -300	0 / -350
k10	+ 40 / 0	+ 48 / 0	+ 58 / 0	+ 70 / 0	+ 84 / 0	+ 100 / 0	+ 120 / 0	+ 140 / 0
k12	+ 100 / 0	+ 120 / 0	+ 150 / 0	+ 180 / 0	+ 210 / 0	+ 250 / 0	+ 300 / 0	+ 350 / 0
m7	+ 2 / + 12	+ 4 / + 16	+ 6 / + 21	+ 7 / + 25	+ 8 / + 29	+ 9 / + 34	+ 11 / + 41	+ 13 / + 48
js14	+ / -125	+ / -150	+ / -180	+ / -215	+ / -260	+ / -310	+ / -370	+ / -435
js16	+ / -300	+ / -375	+ / -450	+ / -550	+ / -650	+ / -800	+ / -950	+ / -1100
H7	+ 10 / 0	+ 12 / 0	+ 15 / 0	+ 18 / 0	+ 21 / 0	+ 25 / 0	+ 30 / 0	+ 35 / 0
H8	+ 14 / 0	+ 18 / 0	+ 22 / 0	+ 27 / 0	+ 33 / 0	+ 39 / 0	+ 46 / 0	+ 54 / 0
H9	+ 25 / 0	+ 30 / 0	+ 36 / 0	+ 43 / 0	+ 52 / 0	+ 62 / 0	+ 74 / 0	+ 87 / 0
H12	+ 100 / 0	+ 120 / 0	+ 150 / 0	+ 180 / 0	+ 210 / 0	+ 250 / 0	+ 300 / 0	+ 350 / 0
P9	-6 / -31	-12 / -42	-15 / -51	-18 / -61	-22 / -74	-26 / -86	-32 / -106	-37 / -124
S7	-13 / -22	-15 / -27	-17 / -32	-21 / -39	-27 / -48	-34 / -59	-42 / -72	-58 / -93



INFORMATIONS TECHNIQUES GÉNÉRALES

Tableau des vitesses de coupe

		Vc															
m/min.		5	8	10	15	20	25	30	40	50	60	70	80	90	100	110	150
SFM (pieds/min.)		16	26	32	50	66	82	98	130	165	197	230	262	296	330	362	495
Ø		Tr/min															
mm	po																
1.00	–	1592	2546	3183	4775	6366	7958	9549	12732	15916	19099	22282	25465	28648	31831	35014	47747
1.50	–	1061	1698	2122	3183	4244	5305	6366	8488	10610	12732	14854	16977	19099	21221	23343	31831
2.00	–	796	1273	1592	2387	3183	3979	4775	6366	7958	9549	11141	12732	14324	15916	17507	23873
2.50	–	637	1019	1273	1910	2546	3183	3820	5093	6366	7639	8913	10186	11459	12732	14006	19099
3.00	–	531	849	1061	1592	2122	2653	3183	4244	5305	6366	7427	8488	9549	10610	11671	15916
3.18	1/8	500	801	1001	1501	2002	2502	3003	4004	5005	6006	7007	8008	9009	10010	11011	15015
3.50	–	455	728	909	1364	1819	2274	2728	3638	4547	5457	6366	7276	8185	9095	10004	13642
4.00	–	398	637	796	1194	1592	1989	2387	3183	3979	4775	5570	6366	7162	7958	8754	11937
4.50	–	354	566	707	1061	1415	1768	2122	2829	3537	4244	4951	5659	6366	7074	7781	10610
4.76	3/16	334	535	669	1003	1337	1672	2006	2675	3344	4012	4681	5350	6018	6687	7356	10031
5.00	–	318	509	637	955	1273	1592	1910	2546	3183	3820	4456	5093	5730	6366	7003	9549
6.00	–	265	424	531	796	1061	1326	1592	2122	2653	3183	3714	4244	4775	5305	5836	7958
6.35	1/4	251	401	501	752	1003	1253	1504	2005	2506	3008	3509	4010	4511	5013	5514	7519
7.00	–	227	364	455	682	909	1137	1364	1819	2274	2728	3183	3638	4093	4547	5002	6821
7.94	5/16	200	321	401	601	802	1002	1203	1604	2004	2405	2806	3207	3608	4009	4410	6013
8.00	–	199	318	398	597	796	995	1194	1592	1989	2387	2785	3183	3581	3979	4377	5968
9.00	–	177	283	354	531	707	884	1061	1415	1768	2122	2476	2829	3183	3537	3890	5305
9.53	3/8	167	267	334	501	668	835	1002	1336	1670	2004	2338	2672	3006	3340	3674	5010
10.00	–	159	255	318	477	637	796	955	1273	1592	1910	2228	2546	2865	3183	3501	4775
11.11	7/16	143	229	287	430	573	716	860	1146	1433	1719	2006	2292	2579	2865	3152	4298
12.00	–	133	212	265	398	531	663	796	1061	1326	1592	1857	2122	2387	2653	2918	3979
12.70	1/2	125	201	251	376	501	627	752	1003	1253	1504	1754	2005	2256	2506	2757	3760
14.00	–	114	182	227	341	455	568	682	909	1137	1364	1592	1819	2046	2274	2501	3410
14.29	9/16	111	178	223	334	446	557	668	891	1114	1337	1559	1782	2005	2228	2450	3341
15.00	–	106	170	212	318	424	531	637	849	1061	1273	1485	1698	1910	2122	2334	3183
15.88	5/8	100	160	200	301	401	501	601	802	1002	1203	1403	1604	1804	2004	2205	3007
16.00	–	99	159	199	298	398	497	597	796	995	1194	1393	1592	1790	1989	2188	2984
17.46	11/16	91	146	182	273	365	456	547	729	912	1094	1276	1458	1641	1823	2005	2735
18.00	–	88	141	177	265	354	442	531	707	884	1061	1238	1415	1592	1768	1945	2653
19.05	3/4	84	134	167	251	334	418	501	668	835	1003	1170	1337	1504	1671	1838	2506
20.00	–	80	127	159	239	318	398	477	637	796	955	1114	1273	1432	1592	1751	2387
24.00	–	66	106	133	199	265	332	398	531	663	796	928	1061	1194	1326	1459	1989
25.00	–	64	102	127	191	255	318	382	509	637	764	891	1019	1146	1273	1401	1910
27.00	–	59	94	118	177	236	295	354	472	589	707	825	943	1061	1179	1297	1768
30.00	–	53	85	106	159	212	265	318	424	531	637	743	849	955	1061	1167	1592
32.00	–	50	80	99	149	199	249	298	398	497	597	696	796	895	995	1094	1492
36.00	–	44	71	88	133	177	221	265	354	442	531	619	707	796	884	973	1326
40.00	–	40	64	80	119	159	199	239	318	398	477	557	637	716	796	875	1194
50.00	–	32	51	64	95	127	159	191	255	318	382	446	509	573	637	700	955



INFORMATIONS TECHNIQUES GÉNÉRALES

Dureté et résistance à la traction

HV	HRC	HB	Résistance	
			N/mm ²	Tonnes/po ²
Vickers	Rockwell	Brinell		
940	68	—	—	—
900	67	—	—	—
864	66	—	—	—
829	65	—	—	—
800	64	—	—	—
773	63	—	—	—
745	62	—	—	—
720	61	—	—	—
698	60	—	—	—
675	59	—	—	—
655	58	—	2200	142
650	—	618	2180	141
640	—	608	2145	139
639	57	607	2140	138
630	—	599	2105	136
620	—	589	2070	134
615	56	584	2050	133
610	—	580	2030	131
600	—	570	1995	129
596	55	567	1980	128
590	—	561	1955	126
580	—	551	1920	124
578	54	549	1910	124
570	—	542	1880	122
560	53	532	1845	119
550	—	523	1810	117
544	52	517	1790	116
540	—	513	1775	115
530	—	504	1740	113
527	51	501	1730	112
520	—	494	1700	110
514	50	488	1680	109
510	—	485	1665	108
500	—	475	1630	105
497	49	472	1620	105
490	—	466	1595	103
484	48	460	1570	102
480	—	456	1555	101
473	47	449	1530	99
470	—	447	1520	98
460	—	437	1485	96
458	46	435	1480	96
450	—	428	1455	94
446	45	424	1440	93
440	—	418	1420	92

HV	HRC	HB	Résistance	
			N/mm ²	Tonnes/po ²
Vickers	Rockwell	Brinell		
434	44	413	1400	91
423	43	402	1360	88
413	42	393	1330	86
403	41	383	1300	84
392	40	372	1260	82
382	39	363	1230	80
373	38	354	1200	78
364	37	346	1170	76
355	36	337	1140	74
350	—	333	1125	73
345	35	328	1110	72
340	—	323	1095	71
336	34	319	1080	70
330	—	314	1060	69
327	33	311	1050	68
320	—	304	1030	67
317	32	301	1020	66
310	31	295	995	64
302	30	287	970	63
300	—	285	965	62
295	—	280	950	61
293	29	278	940	61
290	—	276	930	60
287	28	273	920	60
285	—	271	915	59
280	27	266	900	58
275	—	261	880	57
272	26	258	870	56
270	—	257	865	56
268	25	255	860	56
265	—	252	850	55
260	24	247	835	54
255	23	242	820	53
250	22	238	800	52
245	—	233	785	51
243	21	231	780	50
240	—	228	770	50
235	—	223	755	49
230	—	219	740	48
225	—	214	720	47
220	—	209	705	46
215	—	204	690	45
210	—	199	675	44
205	—	195	660	43
200	—	190	640	41



FORETS
INDEXABLES





PERÇAGE ET ALÉSAGE – CONTENU GÉNÉRAL

6		WMG ET ISO 13399
12	FORETS MONOBLOCS	INSTRUCTIONS
15		FORETS CARBURE
66		FORETS HSS
176		FLUIDES DE COUPE
186		INFORMATIONS TECHNIQUES
190		ALÉSOIRS ET FRAISES À CHANFREINER
264	FORETS INDEXABLES	INSTRUCTIONS
271		FORETS HYDRA À TÊTE INTERCHANGEABLE
297		INFORMATIONS TECHNIQUES
307		FORETS À PLAQUETTES INDEXABLES
327		INFORMATIONS TECHNIQUES
350	SYSTÈMES D'ALÉSAGE	INSTRUCTIONS
359		TÊTES À ALÉSER
376		ACCESSOIRES D'ALÉSAGE
381		PLAQUETTES
404		ATTACHEMENTS
418		KITS D'ALÉSAGE
429		INFORMATIONS TECHNIQUES



PLAQUETTES – PAGE DE PRÉSENTATION



1 SCET

	IC	D1	L	S
	[mm]	[mm]	[mm]	[mm]
0502	5.556	2.40	5.56	2.38
0602	6.350	2.90	6.35	2.38
0703	7.937	3.50	7.94	3.18
09T3	9.525	4.50	9.53	3.97
1204	12.700	5.60	12.70	4.76
1505	15.875	5.60	15.88	5.56

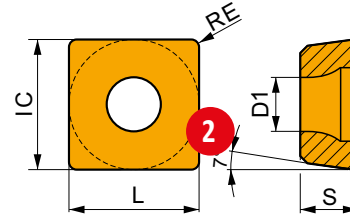

Adéquation et valeurs de départ pour la vitesse de coupe (vc), l'avance (f) et la profondeur de coupe (ap). Reportez-vous à notre application "Calculators" pour d'autres calculs.

Product	RE [mm]	P			M			K			N			S			H		
		vc [m/min]	f [mm/rev]	ap [mm]	vc [m/min]	f [mm/rev]	ap [mm]	vc [m/min]	f [mm/rev]	ap [mm]	vc [m/min]	f [mm/rev]	ap [mm]	vc [m/min]	f [mm/rev]	ap [mm]			

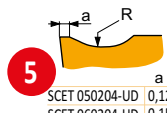

Géométrie SD avec coupe universelle pour plaquettes périphériques.

SCET 050204-UD	0,12
SCET 060204-UD	0,15
SCET 070308-UD	0,15
SCET 09T308-UD	0,15
SCET 120408-UD	0,20
SCET 150512-UD	0,20

SCET 050204-UD	D8330	0.4	165	0.08	-	-	-	-	155	0.08	-	-	-	-	-	-	-	-
	D9335	0.4	240	0.08	-	-	-	-	225	0.08	-	-	-	-	-	-	-	-
SCET 060204-UD	D8330	0.4	165	0.11	-	-	-	-	155	0.11	-	-	-	-	-	-	-	-
	D9335	0.4	240	0.11	-	-	-	-	225	0.11	-	-	-	-	-	-	-	-
SCET 070308-UD	D8330	0.8	165	0.13	-	-	-	-	155	0.13	-	-	-	-	-	-	-	-
	D9335	0.8	240	0.13	-	-	-	-	225	0.13	-	-	-	-	-	-	-	-
SCET 09T308-UD	D8330	0.8	165	0.14	-	-	-	-	155	0.14	-	-	-	-	-	-	-	-
	D9335	0.8	240	0.14	-	-	-	-	225	0.14	-	-	-	-	-	-	-	-
SCET 120408-UD	D8330	0.8	165	0.16	-	-	-	-	155	0.16	-	-	-	-	-	-	-	-
	D9335	0.8	240	0.16	-	-	-	-	225	0.16	-	-	-	-	-	-	-	-
SCET 150512-UD	D8330	1.2	165	0.18	-	-	-	-	155	0.18	-	-	-	-	-	-	-	-
	D9335	1.2	240	0.18	-	-	-	-	225	0.18	-	-	-	-	-	-	-	-

SCET120408-UD:D9335

Mentionner le code complet de la spécification pour toute commande.

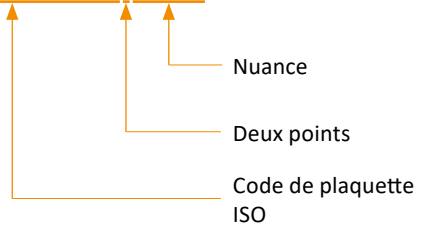



PLAQUETTES – PAGE DE PRÉSENTATION

Élém.	Description	Élém.	Description
1	Désignation de la plaquette	7	Code de plaquette ISO
2	Schéma de la plaquette	8	Nuance
3	Tableau des tailles de plaquette (mm)	9	Rayons de plaquette (mm)
4	Illustration de la plaquette	10	Description de la géométrie
5	Profil de l'arête de coupe principale	11	Conditions de coupe par groupe de matériaux
6	Icônes – caractéristiques spécifiques et type d'arête de coupe		



FORETS À PLAQUETTES – PAGE DE PRÉSENTATION

1 **802D** **P M K N S 2** **PRAMET** **3** **S**



Corps de foret 802D 2xD à plaquettes indexables avec arrosage centralisé
 Corps de foret à plaquettes indexables haute performance pour percer des trous borgnes et débouchants. Egalement pour perçage de trous sé-
 sants, décentrés et empilés, interpolation hélicoïdale, tréflage, perçage sur des surfaces concaves ou inclinées, perçage avec coupes interrompues,
 chanfreinage et alésage dans les paramètres de coupe recommandés. Disponible du Ø15 au Ø40 mm en 2xD. **4**

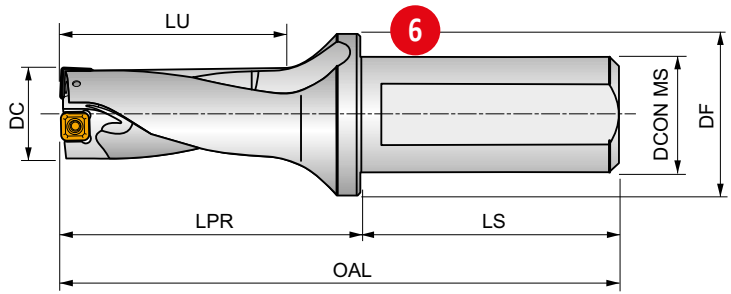

2xD **1** **ISO 9766** **7**



Product	DC	APMX	OAL	LPR	LS	LU	DCON MS	DF	\bar{D}	D^+					
	[mm]	[mm]	[mm]	[mm]	[mm]	[mm]	[mm]	[mm]	[mm]	[mm]					
802D-15-30-S25	15	30.00	121	65	56	34.5	25	35	0.25	0.35	EP253253	GI300	GI313	0.30	HM001
802D-16-32-S25	16	32.00	123	67	56	37	25	35	0.45	0.45	EP253253	GI300	GI313	0.30	HM001
802D-17-34-S25	17	34.00	125	69	56	39.5	25	35	0.50	0.50	EP253253	GI301	GI314	0.31	HM002
802D-18-36-S25	18	36.00	127	71	56	42	25	35	0.35	0.25	EP253253	GI301	GI314	0.31	HM002
802D-19-38-S25	19	38.00	129	73	56	44.5	25	35	0.15	0.45	EP253253	GI301	GI314	0.32	HM002

GI300	XPET 0502AP	SCET 050204-UD
GI301	XPET 0602AP	SCET 050204-UD
GI302	XPET 0602AP	SCET 060204-UD
GI303	XPET 0703AP	SCET 060204-UD
GI304	XPET 0703AP	SCET 070308-UD
GI305	XPET 0903AP	SCET 070308-UD
GI306	XPET 0903AP	SCET 09T308-UD
GI307	XPET 11T3AP	SCET 09T308-UD
GI308	XPET 11T3AP	SCET 120408-UD
GI309	XPET 12T3AP	SCET 120408-UD
GI313	XPET 0502AP-SD	SCET 050204-SD
GI314	XPET 0602AP-SD	SCET 050204-SD
GI315	XPET 0602AP-SD	SCET 060204-SD
GI316	XPET 0703AP-SD	SCET 060204-SD
GI317	XPET 0703AP-SD	SCET 070308-SD
GI318	XPET 0903AP-SD	SCET 070308-SD
GI319	XPET 0903AP-SD	SCET 09T308-SD
GI320	XPET 11T3AP-SD	SCET 09T308-SD
GI321	XPET 11T3AP-SD	SCET 120408-SD
GI322	XPET 12T3AP-SD	SCET 120408-SD

GI300	XPET 0502AP	SCET 050204-UD
GI301	XPET 0602AP	SCET 050204-UD
GI302	XPET 0602AP	SCET 060204-UD
GI303	XPET 0703AP	SCET 060204-UD



FORETS À PLAQUETTES – PAGE DE PRÉSENTATION

Élém.	Description	Élém.	Description
1	Désignation du foret	11	Caractéristiques radiales (mm)
2	Groupe de matériaux recommandés	12	Douille de réglage
3	Système de serrage de la plaquette	13	Groupe de plaquettes compatibles avec brise-copeau UD ^{1), 2)}
4	Description de l'outil	14	Groupe de plaquettes compatibles avec brise-copeau SD ^{1), 2)}
5	Illustration	15	Poids (kg)
6	Schéma de l'outil	16	Groupe de pièces de rechange ¹⁾
7	Caractéristiques du produit	17	Plaquettes compatibles avec brise-copeau UD
8	Applications du produit	18	Plaquettes compatibles avec brise-copeau SD
9	Code de l'outil	19	Pièces de rechange
10	Dimensions de l'outil		

¹⁾ Le code du groupe de plaquettes et pièces de rechange compatibles est uniquement utile aux fins du présent catalogue. Il ne permet pas de faire des commandes.

²⁾ Les plaquettes externes (SCET) et internes (XPET) doivent toujours avoir le même brise-copeaux. Remarque : le brise-copeaux UD n'apparaît pas dans la désignation des plaquettes XPET (XPET 0502AP, par ex.) ; les informations nécessaires au choix du bon brise-copeau (UD ou SD) se trouvent sur l'emballage de la plaquette.



FORETS HYDRA À TÊTE INTERCHANGEABLE – PAGE DE PRÉSENTATION

1

H851

DORMER



Corps HYDRA 1,5XD, avec arrosage centralisé, nickelage brillant

Corps utilisable avec les têtes R950, R960 et R970 HYDRA. Une gamme de diamètres de tête peut être utilisée avec le même corps. Les trous d'arrosage centralisé alignés avec les têtes offrent un refroidissement efficace. La queue épaulée empêche le foret de se déplacer dans l'attachement. La surface nickelée protège de la corrosion et améliore l'évacuation des copeaux.

2

HYDRA

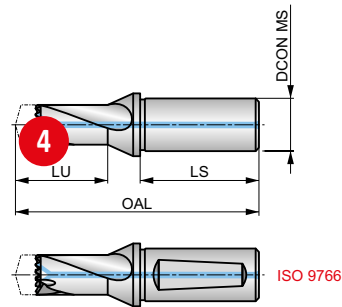

HSS	DORMER	1.5xD
Bright Ni	ISO 9766	R

5

Quatre (4) vis et un (1) tournevis sont livrés avec le corps du foret, DCON MS tolérance h6.

Product	DCONMS	DCON MS	LU	OAL	LS	ADINTMS
	[inch]	[mm]	[mm]	[mm]	[mm]	
H85131/64	5/8	15.88	25.50	88.5	47.6	Cylindrical
H8511/2	5/8	15.88	25.80	88.8	47.6	Cylindrical
H85117/32	5/8	15.88	30.90	93.9	47.6	Cylindrical
H85112.0	–	16.00	25.50	88.5	48.0	ISO 9766
H85112.5	–	16.00	25.80	88.8	48.0	ISO 9766
H85113.0	–	16.00	27.00	90.0	48.0	ISO 9766
H85114.0	–	16.00	30.90	93.9	48.0	ISO 9766
H8519/16	3/4	19.05	30.30	93.9	50.8	Cylindrical
H85139/64	3/4	19.05	32.30	97.3	50.8	Cylindrical
H85114/64	3/4	19.05	32.30	99.9	50.8	Cylindrical
H85116	3/4	19.05	39.00	101.4	50.8	Cylindrical
H85123/32	3/4	19.05	39.00	104.0	50.8	Cylindrical
H85115.0	–	20.00	32.30	97.3	50.0	ISO 9766
H85116.0	–	20.00	34.90	99.9	50.0	ISO 9766
H85117.0	–	20.00	36.40	101.4	50.0	ISO 9766
H85118.0	–	20.00	39.00	104.0	50.0	ISO 9766
H85119.0	–	25.00	40.40	111.4	56.0	ISO 9766
H85120.0	–	25.00	43.00	114.0	56.0	ISO 9766
H85121.0	–	25.00	44.50	115.5	56.0	ISO 9766

6

7

Élém.	Description
1	Désignation du foret
2	Descriptif du produit
3	Illustration
4	Schéma de l'outil

Élém.	Description
5	Caractéristiques du produit
6	Code produit
7	Dimensions du produit



FORETS INDEXABLES – PRÉSENTATION DES ICÔNES

ICÔNES GÉNÉRALES

 Utilisation principale

 Utilisation possible

ANGLE DE TRAVAIL

 Pointe à 140°

NORME (BSG)

 Normes Dormer

TYPE DE SERRAGE

 Serrage à vis de style S

REVÊTEMENT

 Nickelage brillant

 Revêtement TiAlN spécial (+ silicium + chrome)

PROPRIÉTÉ D'ARROSAGE (CSP)

 Arrosage centralisé

CLASSE DE TOLÉRANCE DU DIAMÈTRE DE COUPE (TCDC)

 h7 – Tolérance de perçage norme usine (selon diamètre)

SENS DE COUPE

 Rotation / coupe à droite

CARACTÉRISTIQUES GÉNÉRALES

 1 dent par tour

 Conception monobloc

 Compatible usinage excentrique

 Queue universelle

ARÊTE DE COUPE DE LA PLAQUETTE

 Arête ronde avec facette

CARACTÉRISTIQUES DE LA PLAQUETTE

 Pour matériaux tenaces (copeaux longs)

 Usinage lourd

 Gamme d'options universelles

CODE MATÉRIAU (BMC)

 Substrat dur (carbure monobloc)

 Substrat acier rapide

OPÉRATIONS DE PERÇAGE

 Alésage de trous borgnes

 Perçage de trous borgnes

 Alésage

 Alésage sur trous sécants

 Alésage sur épaulement

 Perçage débouchant sur surface inclinée

 Perçage dans un trou existant

 Perçage de matériaux empilés

 Perçage sur surface courbe

 Perçage sur surface inclinée

 Alésage par interpolation hélicoïdale

 Perçage par interpolation hélicoïdale

 Chanfreinage (biseautage)

 Coupe discontinue

 Alésage de trous débouchants

 Perçage de trous débouchants

 Perçage de soudures



FORETS INDEXABLES – PRÉSENTATION DES ICÔNES

AUTRES ICÔNES



Couple de serrage de la vis (Nm)

QUEUE



Queue cylindrique avec collerette



ISO 9766 – Queues cylindriques (avec ou sans méplat)



DIN 6535HB
DIN 6535HE
DIN 6535 – Queue HB (Weldon) ou HE (Whistle)

FICHES TECHNIQUES



Avance (mm/tour)



Vitesse de coupe élevée, rigidité du système légèrement limitée (variation de la profondeur de coupe)



Vitesse de coupe faible, mauvaise rigidité du système (coupe interrompue)



Vitesse de coupe très élevée, excellente rigidité du système (conditions de travail stables)



Vitesse de coupe moyenne, rigidité du système limitée (coupe légèrement interrompue)



Vitesse de coupe très faible, très mauvaise rigidité du système (conditions de travail très instables)



Vitesse de coupe élevée, bonne rigidité du système (conditions de travail stables)

RAPPORT LONGUEUR UTILE DIAMÈTRE (ULDR)

1.5xD

1.5xD Rapport entre la profondeur utile de l'outil et son diamètre

5xD

5xD Rapport entre la profondeur utile de l'outil et son diamètre

2xD

2xD Rapport entre la profondeur utile de l'outil et son diamètre

12xD

12xD Rapport entre la profondeur utile de l'outil et son diamètre

8xD

8xD Rapport entre la profondeur utile de l'outil et son diamètre

4xD

4xD Rapport entre la profondeur utile de l'outil et son diamètre

3xD

3xD Rapport entre la profondeur utile de l'outil et son diamètre



FORETS HYDRA À TÊTE INTERCHANGEABLE



HYDRA

FORETS HAUTE PERFORMANCE À TÊTE INTERCHANGEABLE

Nous avons complété notre gamme existante de forets Hydra par l'introduction de longueurs de corps supplémentaires en $12 \times D$ pour les applications de perçages profonds et $1,5 \times D$ pour une rigidité accrue pour le perçage de faible profondeur et le perçage de plaques. Leur compatibilité est totale avec toute la famille des têtes en carbure monobloc pour l'usinage dans l'acier, l'acier inoxydable et la fonte.

CARACTÉRISTIQUES ET AVANTAGES

- **Performances toujours élevées**, même après de nombreux changements de tête.
- **Réduction des coûts de stock** – plusieurs dimensions de têtes en carbure monobloc peuvent se monter sur un seul et même corps.
- **Polyvalence** – la queue cylindrique avec plat permet un montage avec différents attachements.
- **Changements rapides et faciles de la tête** avec interruptions minimales du processus de production. Possibilité de changer de tête sans enlever le corps de la machine.
- L'adaptation précise de la tête sur le corps améliore la rigidité de l'outil, pour une **précision supérieure de perçage** et des tolérances précises.

MATÉRIAU

CARBURE MICROGRAIN PREMIUM (têtes)

- Le carbure micrograin combine à merveille dureté et ténacité, avec pour résultats une résistance élevée à l'usure et une durée de vie accrue de l'outil.

ACIER TREMPÉ (corps)

- Acier trempé nickelé haute brillance pour une résistance élevée à l'usure et à la corrosion.

REVÊTEMENT

LE REVÊTEMENT À BASE DE NITRURE DE TITANE ALUMINIUM PRÉSENTE LES AVANTAGES SUIVANTS:

- Haute ténacité et résistance à l'oxydation.
- Protection exceptionnelle contre l'usure dans les matériaux abrasifs comme la fonte.
- Haute dureté aux températures élevées engendrées par le perçage dans les fontes.
- Productivité et durée de vie accrues.

TYPE DE TÊTE



R950

ACIER



R960

ACIER
INOXYDABLE



R970

FONTE



HYDRA

FORETS HAUTE PERFORMANCE À TÊTE INTERCHANGEABLE

GÉOMÉTRIE

FORME DE L'ANGLE EXTÉRIEUR

- L'angle extérieur est conçu robuste pour accroître la stabilité pendant le perçage et réduire les forces opposées lorsque le foret débouche du trou.
- La qualité de la surface de sortie est ainsi améliorée et on évite l'à-coup à la sortie de perçage dans certains matériaux granulaires.

GÉOMÉTRIE DE POINTE

- La géométrie à affûtage en croix à 140 degrés permet un centrage de bonne qualité et réduit l'effort de poussée pour le perçage dans la plupart des matériaux.

UNE GAMME COMPLÈTE

- Disponibles en longueur $1,5 \times \varnothing$, $3 \times \varnothing$, $5 \times \varnothing$, $8 \times \varnothing$ et $12 \times \varnothing$ avec canaux de refroidissement incorporés pour améliorer l'efficacité de coupe et l'évacuation des copeaux, et par conséquent la productivité.
- Métrique: de 12,00 mm à 42,00 mm.
- Pouce: de 15/32" à 1,5/8".
- Les meilleurs résultats sont obtenus avec les porte-outils hydrauliques. Montage également possible sur porte-outils type ER et Weldon.



LONGUEURS DE CORPS

1.5×D



3×D



5×D



8×D



12×D





FORETS HYDRA – RECHERCHE PAR MATÉRIAU D'OUTIL



Matériaux

Acier rapide		Un acier rapide moyennement allié qui présente une bonne usinabilité et de bonnes performances. L'acier rapide présente des caractéristiques de dureté, de ténacité et de résistance à l'usure qui en font un bon choix pour une large gamme d'applications, notamment pour les forets et les tarauds.
---------------------	---	--

Carbures

Carbures (ou matériaux durs)		<p>Substrat fritté de la métallurgie des poudres, constitué d'un composite de carbure métallique avec un métal liant. La matière première essentielle est le carbure de tungstène (WC). C'est lui qui confère sa dureté au matériau. Le carbure de tantale (TaC), le carbure de titane (TiC) et le carbure de niobium (NbC) viennent compléter le WC pour obtenir les propriétés spécifiques recherchées. Ces trois matériaux sont appelés des « carbures cubiques ». Le cobalt (Co) sert de liant et assure donc l'homogénéité du matériau final.</p> <p>Les matériaux au carbure se caractérisent généralement par une haute résistance à la compression, une dureté élevée et donc une grande résistance à l'usure, mais aussi une résistance à la flexion et une ténacité limitées. Le carbure est utilisé dans la fabrication de tarauds, d'alésoirs, de fraises, de forets et de fraises à fileter.</p>
---	---	---

Revêtements de surface

Nickelage brillant		Le nickelage brillant protège le corps en acier trempé de la rouille, de la corrosion et améliore l'évacuation des copeaux.
Ti-phon (TiAlCrSiN)		Le revêtement Ti-phon est similaire au TiAlN, mais il comporte en plus du chrome (Cr) et du silicium (Si). Il est spécialement formulé pour les têtes Hydra afin d'éviter la formation d'arête rapportée et d'améliorer considérablement le flux de copeaux. Ce revêtement présente une dureté à chaud élevée, une grande résistance à l'oxydation et un pouvoir lubrifiant supérieur lorsqu'il est utilisé sur des outils destinés à des usinages sous fortes contraintes mécaniques et thermiques, des vitesses et des avances élevées. Les propriétés de ce revêtement se traduisent par une résistance supérieure à l'usure et une plus grande robustesse des arêtes.



DORMER PRAMET



TOUS LES OUTILS ENSEMBLE

Notre assortiment complet d'outils monoblocs et à plaquettes indexables est inclus dans l'application calculatrice d'usinage. Cela représente plus de 40 000 articles! Quel que soit votre usinage, nous avons probablement quelque chose pour cela. Tout simplement fiable. **Simply Reliable.**

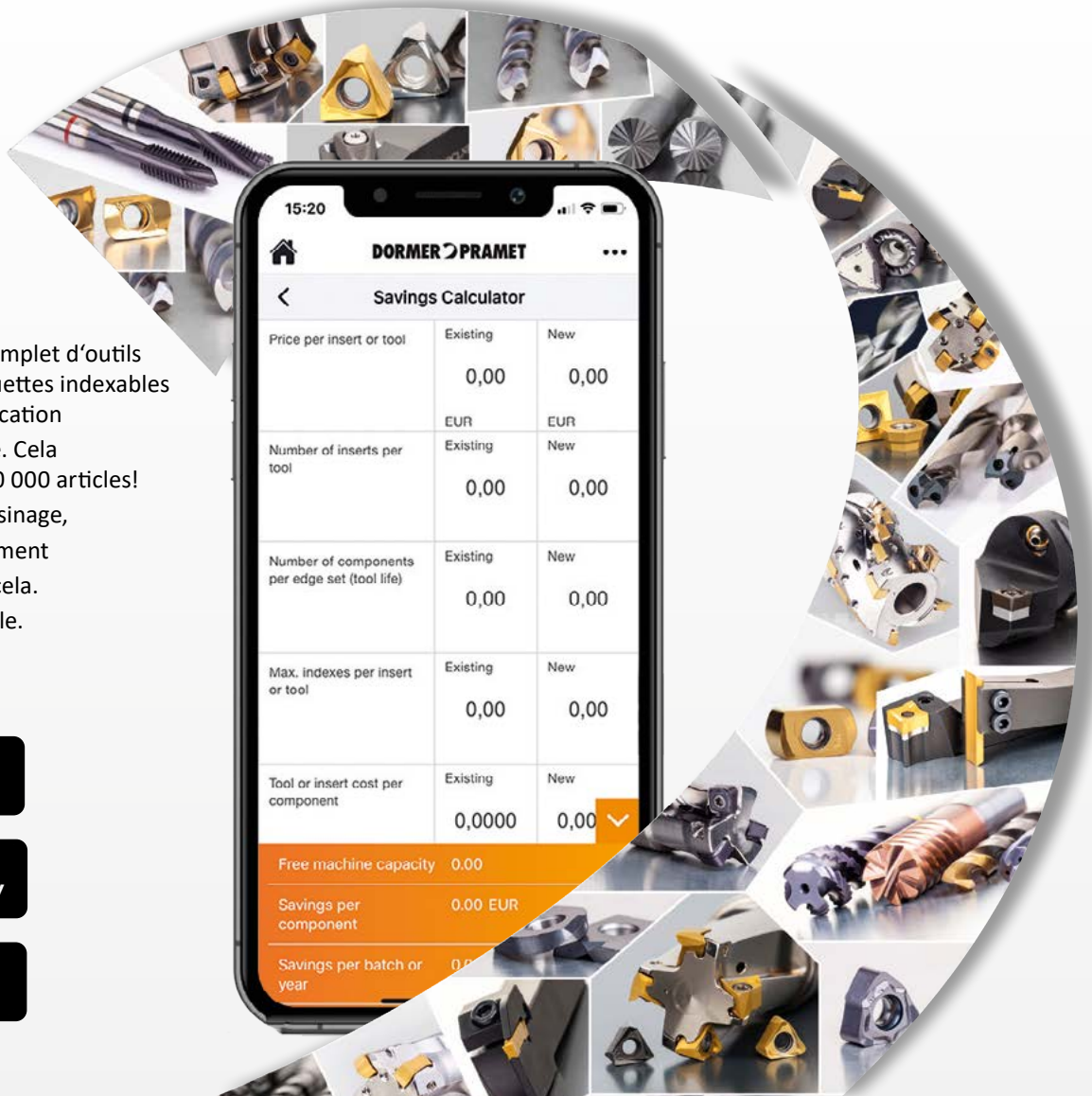

DORMER PRAMET		
Savings Calculator		
Price per insert or tool	Existing 0,00	New 0,00
	EUR	EUR
Number of inserts per tool	Existing 0,00	New 0,00
Number of components per edge set (tool life)	Existing 0,00	New 0,00
Max. indexes per insert or tool	Existing 0,00	New 0,00
Tool or insert cost per component	Existing 0,0000	New 0,00
Free machine capacity	0.00	
Savings per component	0.00 EUR	
Savings per batch or year	0.00	









		HM	HM	HM	HSS	HSS	HSS	HSS	HSS				
Code de matériau du corps (BMC)		HM	HM	HM	HSS	HSS	HSS	HSS	HSS				
Groupe standard de base (BSG)		DORMER	DORMER	DORMER	DORMER	DORMER	DORMER	DORMER	DORMER				
Rapport longueur utile diamètre (ULDR)					1.5xD	3xD	5xD	8xD	12xD				
Angle d'application		140°	140°	140°									
Revêtement		Ti-phon	Ti-phon	Ti-phon	Bright Ni	Bright Ni	Bright Ni	Bright Ni	Bright Ni				
Queue					ISO 9766	DIN 6535HB DIN 6535HE	DIN 6535HB DIN 6535HE	DIN 6535HB DIN 6535HE	DIN 6535HB DIN 6535HE				
Sens (direction de coupe)		R	R	R	R	R	R	R	R				
Propriété d'alimentation en liquide de coupe (CSP)													
		HYDRA	HYDRA	HYDRA	HYDRA	HYDRA	HYDRA	HYDRA	HYDRA	HYDRA	HYDRA	HYDRA	HYDRA
					NEW				NEW				
Code de famille de produits		R950	R960	R970	H851	H853	H855	H858	H8512	H860	H861		
		12.00 - 42.00, 15/32 - 1.5/8	12.00 - 30.50, 15/32 - 1.3/16	12.00 - 42.00, 15/32 - 1.5/8	12.00 - 30.50, 15/32 - 1.3/16	12.00 - 42.50, 15/32 - 1.5/8	12.00 - 42.50, 15/32 - 1.5/8	13.50 - 42.50, 35/64 - 1.5/8	13.50 - 25.65, 35/64 - 1.1/64	N1 - N7	N1 - N6		
		281	283	285	287	289	291	293	294	295	296		
P	P1	■	■										
	P2	■	■										
	P3	■											
	P4	■											
M	M1		■										
	M2		■										
	M3		■										
	M4		■										
K	K1		■	■									
	K2	■	■	■									
	K3	■	■	■									
	K4	■	■	■									
	K5	■	■	■									
N	N1												
	N2												
	N3												
	N4												
	N5												
S	S1		■										
	S2		■										
	S3		■										
	S4		■										
H	H1												
	H2												
	H3												
	H4												

■ Utilisation principale ■ Utilisation possible

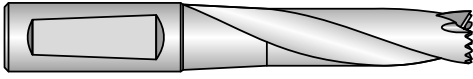

FORETS HAUTE PERFORMANCE À TÊTE INTERCHANGEABLE

Configuration										
	DC	H851 1.5×D	H853 3×D	H855 5×D	H858 8×D	H8512 12×D	R950	R960	R970	H860
Plage	12.00 – 30.50 15/32" – 1.3/16"	12.00 – 42.50 15/32" – 1.5/8"	12.00 – 42.50 15/32" – 1.5/8"	13.50 – 42.50 35/64" – 1.5/8"	13.50 – 25.65 35/64" – 1.1/64"	12.00 – 42.00 15/32" – 1.5/8"	12.00 – 30.50 15/32" – 1.3/16"	12.00 – 42.00 15/32" – 1.5/8"	N1 – N7	N1 – N6
Pages	287	289	291	293	294	281	283	285	295	296

DC	H851 1.5×D	H853 3×D	H855 5×D	H858 8×D	H8512 12×D	R950	R960	R970	H860	H861
15/32"						R95015/32	R96015/32	R97015/32		
12.0						R95012.0	R96012.0	R97012.0		
12.1	H85112.0	H85312.0	H85512.0	–	–	R95012.1	R96012.1	R97012.1		
12.2	H85131/64	H85331/64	H85531/64			R95012.2	R96012.2	R97012.2		
31/64"						R95031/64	R96031/64	R97031/64		
12.5						R95012.5	R96012.5	R97012.5		
12.6						R95012.6	R96012.6	R97012.6		
1/2"	H85112.5	H85312.5	H85512.5	–	–	R9501/2	R9601/2	R9701/2		
12.8	H8511/2	H8531/2	H8551/2			R95012.8	R96012.8	R97012.8		
12.9						R95012.9	R96012.9	R97012.9		
13.0						R95013.0	R96013.0	R97013.0		
33/64"						R95033/64	R96033/64	R97033/64		
13.2	H85113.0	H85313.0	H85513.0	–	–	R95013.2	R96013.2	R97013.2		
17/32"	H85117/32	H85317/32	H85517/32			R95017/32	R96017/32	R97017/32		
13.5						R95013.5	R96013.5	R97013.5		
13.6						R95013.6	R96013.6	R97013.6		
13.7						R95013.7	R96013.7	R97013.7		
13.8						R95013.8	R96013.8	R97013.8		
35/64"	H85114.0	H85314.0	H85514.0	H85814.0	H851214.0	R95035/64	R96035/64	R97035/64	H860N1	H861N1
14.0	H8519/16	H8539/16	H8559/16			R95014.0	R96014.0	R97014.0		
14.1						R95014.1	R96014.1	R97014.1		
14.2						R95014.2	R96014.2	R97014.2		
9/16"						R9509/16	R9609/16	R9709/16		
14.5						R95014.5	R96014.5	R97014.5		
14.6						R95014.6	R96014.6	R97014.6		
37/64"						R95037/64	R96037/64	R97037/64		
14.7						R95014.7	R96014.7	R97014.7		
14.8						R95014.8	R96014.8	R97014.8		
15.0						R95015.0	R96015.0	R97015.0		
19/32"	H85115.0	H85315.0	H85515.0	H85815.0	H851215.0	R95019/32	R96019/32	R97019/32		
15.1	H85139/64	H85339/64	H85539/64			R95015.1	R96015.1	R97015.1		
15.2						R95015.2	R96015.2	R97015.2		
15.24						R95015.24	R96015.24	R97015.24		
39/64"						R95039/64	R96039/64	R97039/64		
15.5						R95015.5	R96015.5	R97015.5		



FORETS HAUTE PERFORMANCE À TÊTE INTERCHANGEABLE

DC	H851 1.5×D	H853 3×D	H855 5×D	H858 8×D	H8512 12×D	R950	R960	R970	H860	H861							
15.6	H85116.0	H85316.0	H85516.0	H85816.0	H851216.0	R95015.6	R96015.6	R97015.6	H860N2	H861N2							
15.7						R95015.7	R96015.7	R97015.7									
5/8"						R9505/8	R9605/8	R9705/8									
16.0						R95016.0	R96016.0	R97016.0									
16.08						R95016.08	R96016.08	R97016.08									
16.1						R95016.1	R96016.1	R97016.1									
16.2						R95016.2	R96016.2	R97016.2									
16.3						R95016.3	R96016.3	R97016.3									
41/64"						R95041/64	R96041/64	R97041/64									
16.5						R95016.5	R96016.5	R97016.5									
16.6	H85117.0	H85317.0	H85517.0	H85817.0	H851217.0	R95016.6	R96016.6	R97016.6	H860N2	H861N2							
21/32"						R95021/32	R96021/32	R97021/32									
16.7						R95016.7	R96016.7	R97016.7									
17.0						R95017.0	R96017.0	R97017.0									
43/64"						R95043/64	R96043/64	R97043/64									
17.1						R95017.1	R96017.1	R97017.1									
17.2						R95017.2	R96017.2	R97017.2									
11/16"						R95011/16	R96011/16	R97011/16									
17.5						R95017.5	R96017.5	R97017.5									
17.6						H85118.0	H85318.0	H85518.0			H85818.0	H851218.0	R95017.6	R96017.6	R97017.6	H860N3	H861N3
17.7	R95017.7	R96017.7	R97017.7														
45/64"	R95045/64	R96045/64	R97045/64														
18.0	R95018.0	R96018.0	R97018.0														
18.1	R95018.1	R96018.1	R97018.1														
18.2	R95018.2	R96018.2	R97018.2														
23/32"	R95023/32	R96023/32	R97023/32														
18.5	R95018.5	R96018.5	R97018.5														
18.6	H85119.0	H85319.0	H85519.0	H85819.0	H851219.0				R95018.6	R96018.6			R97018.6	H860N3	H861N3		
47/64"									R95047/64	R96047/64			R97047/64				
18.7						R95018.7	R96018.7	R97018.7									
18.9						R95018.9	R96018.9	R97018.9									
19.0						R95019.0	R96019.0	R97019.0									
3/4"						R9503/4	R9603/4	R9703/4									
19.1						R95019.1	R96019.1	R97019.1									
19.2						R95019.2	R96019.2	R97019.2									
19.25						R95019.25	R96019.25	R97019.25									
19.3						R95019.3	R96019.3	R97019.3									
19.35	R95019.35	R96019.35	R97019.35														
49/64"	R95049/64	R96049/64	R97049/64														
19.5	R95019.5	R96019.5	R97019.5	H860N4	H861N3												
19.6	R95019.6	R96019.6	R97019.6														
19.7	R95019.7	R96019.7	R97019.7														
25/32"	R95025/32	R96025/32	R97025/32														
20.0	R95020.0	R96020.0	R97020.0														
51/64"	R95051/64	R96051/64	R97051/64														
20.5	R95020.5	R96020.5	R97020.5														
13/16"	R95013/16	R96013/16	R97013/16														
21.0	R95021.0	R96021.0	R97021.0														
53/64"	R95053/64	R96053/64	R97053/64														
27/32"	R95027/32	R96027/32	R97027/32														
21.5	R95021.5	R96021.5	R97021.5	H860N4	H861N3												
55/64"	R95055/64	R96055/64	R97055/64														
22.0	R95022.0	R96022.0	R97022.0														
7/8"	R9507/8	R9607/8	R9707/8														
22.5	R95022.5	R96022.5	R97022.5														
57/64"	R95057/64	R96057/64	R97057/64														
22.7	R95022.7	R96022.7	R97022.7														
23.0	R95023.0	R96023.0	R97023.0														
29/32"	R95029/32	R96029/32	R97029/32														
59/64"	R95059/64	R96059/64	R97059/64														
23.5	R95023.5	R96023.5	R97023.5														



FORETS HAUTE PERFORMANCE À TÊTE INTERCHANGEABLE

DC	H851 1.5×D	H853 3×D	H855 5×D	H858 8×D	H8512 12×D	R950	R960	R970	H860	H861
15/16	H85124.0 H85131/32	H85324.0 H85331/32	H85524.0 H85531/32	H85824.0	H851224.0	R95015/16	R96015/16	R97015/16	H860N4	H861N3
24.0						R95024.0	R96024.0	R97024.0		
61/64						R95061/64	R96061/64	R97061/64		
24.5						R95024.5	R96024.5	R97024.5		
31/32"						R95031/32	R96031/32	R97031/32		
25.0	H85125.0 H8511.1/64	H85325.0 H8531.1/64	H85525.0 H8551.1/64	H85825.0	H851225.0	R95025.0	R96025.0	R97025.0	H860N5	H861N4
63/64"						R95063/64	R96063/64	R97063/64		
1"						R9501	R9601	R9701		
25.5						R95025.5	R96025.5	R97025.5		
25.6						R95025.6	–	–		
25.65						R95025.65	R96025.65	R97025.65		
1.1/64"						R9501.1/64	R9601.1/64	R9701.1/64		
26.0						R95026.0	R96026.0	R97026.0		
1.1/32"						R9501.1/32	R9601.1/32	R9701.1/32		
26.5						R95026.5	R96026.5	R97026.5		
1.3/64	R9501.3/64	R9601.3/64	R9701.3/64							
1.1/16"	H85127.0 H8511.3/32	H85327.0 H8531.3/32	H85527.0 H8551.3/32	H85827.0	–	R9501.1/16	R9601.1/16	R9701.1/16	H860N6	H861N5
27.0						R95027.0	R96027.0	R97027.0		
1.5/64"						R9501.5/64	R9601.5/64	R9701.5/64		
27.5						R95027.5	R96027.5	R97027.5		
1.3/32"						R9501.3/32	R9601.3/32	R9701.3/32		
28.0	H85128.0 H8511.1/8	H85328.0 H8531.1/8	H85528.0 H8551.1/8	H85828.0	–	R95028.0	R96028.0	R97028.0	H860N7	H861N6
1.7/64"						R9501.7/64	R9601.7/64	R9701.7/64		
28.5						R95028.5	R96028.5	R97028.5		
1.1/8"						R9501.1/8	R9601.1/8	R9701.1/8		
1.9/64"						R9501.9/64	R9601.9/64	R9701.9/64		
29.0	H85129.0 H8511.11/64	H85329.0 H8531.11/64	H85529.0 H8551.11/64	H85829.0	–	R95029.0	R96029.0	R97029.0	H860N8	H861N7
1.5/32"						R9501.5/32	R9601.5/32	R9701.5/32		
29.5						R95029.5	R96029.5	R97029.5		
1.11/64"						R9501.11/64	R9601.11/64	R9701.11/64		
30.0						R95030.0	R96030.0	R97030.0		
1.3/16"	H85130.0 H8511.3/16	H85330.0 H8531.3/16	H85530.0 H8551.3/16	H85830.0	–	R9501.3/16	R9601.3/16	R9701.3/16	H860N9	H861N8
30.5						R95030.5	R96030.5	R97030.5		
1.7/32"						R9501.7/32	–	R9701.7/32		
31.0						R95031.0	–	R97031.0		
1.1/4"						R9501.1/4	–	R9701.1/4		
32.0	R95032.0	–	R97032.0							
32.5	–	H85332.0	H85532.0	H85832.0	–	R95032.5	–	R97032.5	H860N10	H861N9
1.19/64"						R9501.19/64	–	R9701.19/64		
33.0						R95033.0	–	R97033.0		
33.5						R95033.5	–	R97033.5		
34.0						R95034.0	–	R97034.0		
1.11/32"	–	H85333.5	H85533.5	H85833.5	–	R9501.11/32	–	R9701.11/32	H860N11	H861N10
34.5						R95034.5	–	R97034.5		
1.3/8"						R9501.3/8	–	R9701.3/8		
35.0						R95035.0	–	R97035.0		
36.0						R95036.0	–	R97036.0		
1.27/64"	–	H85334.0	H85534.0	H85834.0	–	R9501.27/64	–	R9701.27/64	H860N12	H861N11
36.5						R95036.5	–	R97036.5		
37.0						R95037.0	–	R97037.0		
1.15/32"						R9501.15/32	–	R9701.15/32		
37.5						R95037.5	–	R97037.5		
38.0	R95038.0	–	R97038.0							
1.1/2"	–	H85335.0	H85535.0	H85835.0	–	R9501.1/2	–	R9701.1/2	H860N13	H861N12
38.5						R95038.5	–	R97038.5		
1.17/32"						R9501.17/32	–	R9701.17/32		
39.0						R95039.0	–	R97039.0		
39.5						R95039.5	–	R97039.5		
1.9/16"	–	H85336.5	H85536.5	H85836.5	–	R9501.9/16	–	R9701.9/16	H860N14	H861N13
40.0						R95040.0	–	R97040.0		
41.0						R95041.0	–	R97041.0		



FORETS HAUTE PERFORMANCE À TÊTE INTERCHANGEABLE

DC	H851 1.5×D	H853 3×D	H855 5×D	H858 8×D	H8512 12×D	R950	R960	R970	H860	H861
1.5/8"	–	H85342.5	H85542.5	H85842.5	–	R9501.5/8	–	R9701.5/8	H860N7	H861N6
42.0						R95042.0	–	R97042.0		

Accessoires

H860	H861	Gamme têtes Hydra DC			Taille de clé / embout
		Métrique (min. – max.)	Fractions (min. – max.)	Décimal (min. – max.)	
H860N1	H861N1	12.0 mm – 15.5 mm	15/32" – 39/64"	0.4688" – 0.6102"	8IP
H860N2	H861N2	15.6 mm – 18.5 mm	5/8" – 23/32"	0.6142" – 0.7283"	10IP
H860N3	H861N3	18.6 mm – 21.5 mm	47/64" – 27/32"	0.7323" – 0.8465"	15IP
H860N4	H861N3	22.0 mm – 24.5 mm	55/64" – 31/32"	0.8594" – 0.9688"	15IP
H860N5	H861N4	25.0 mm – 27.5 mm	63/64" – 1-3/32"	0.9843" – 1.0938"	20IP
H860N6	H861N5	28.0 mm – 33.5 mm	1-7/64" – 1-19/64"	1.1024" – 1.3189"	25IP
H860N7	H861N6	34.0 mm – 42.0 mm	1-11/32" – 1-5/8"	1.3386" – 1.6535"	4 mm



R950

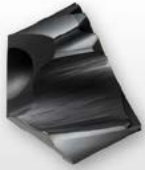

Tête de perçage HYDRA pour les aciers, revêtement Ti-phon

Tête interchangeable précise (tolérance de la tête h7) pour des performances élevées dans les aciers et les matériaux durs. Un affûtage en croix à 140° facilite l'auto-centrage et réduit les forces de coupe. Le revêtement Ti-phon empêche le phénomène d'arête rapportée et améliore considérablement le glissement des copeaux, avec une résistance à l'usure et une solidité des arêtes supérieures.

HYDRA

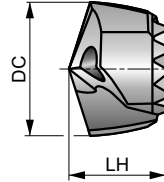

HM	DORMER	140°
Ti-phon	R	
DC h7		

H851	Appliquer les valeurs de vitesse et d'avance initiales avec un facteur de correction de 1.10
H853	Appliquer les valeurs de vitesse et d'avance initiales avec un facteur de correction de 1.00
H855	Appliquer les valeurs de vitesse et d'avance initiales avec un facteur de correction de 0.95
H858	Appliquer les valeurs de vitesse et d'avance initiales avec un facteur de correction de 0.90
H8512	Appliquer les valeurs de vitesse et d'avance initiales avec un facteur de correction de 0.80

Adéquation du groupe de matériaux de la pièce, valeurs de départ pour la vitesse de coupe (m/min) et code Alpha d'avance.

P1.1 ■ 133 W	P1.2 ■ 148 W	P1.3 ■ 154 W	P2.1 ■ 114 W	P2.2 ■ 100 W	P2.3 ■ 88 W	P3.1 ■ 125 W	P3.2 ■ 101 W	P3.3 ■ 85 W	P4.1 ■ 75 W	P4.2 ■ 63 W	P4.3 ■ 52 T	M2.3 ■ 41 T	M4.2 ■ 35 T
K2.1 ■ 108 V	K2.2 ■ 88 V	K2.3 ■ 70 V	K3.1 ■ 96 V	K3.2 ■ 73 V	K3.3 ■ 59 V	K4.1 ■ 89 V	K4.2 ■ 67 V	K4.3 ■ 49 V	K4.4 ■ 42 V	K4.5 ■ 35 V	K5.1 ■ 100 V	K5.2 ■ 76 V	K5.3 ■ 58 V

Produit	DC	DC	DC	LH	Produit	DC	DC	DC	LH
	(inch)	(mm)	(inch)	(mm)		(inch)	(mm)	(inch)	(mm)
R95015/32	15/32	11.91	0.4688	9.1	R95015.1	—	15.10	0.5945	11.0
R95012.0	—	12.00	0.4724	9.1	R95015.2	—	15.20	0.5984	11.0
R95012.1	—	12.10	0.4764	9.1	R95015.24	—	15.24	0.6000	11.0
R95012.2	—	12.20	0.4803	9.1	R95039/64	39/64	15.48	0.6094	11.0
R95031/64	31/64	12.30	0.4844	9.1	R95015.5	—	15.50	0.6102	11.0
R95012.5	—	12.50	0.4921	9.4	R95015.6	—	15.60	0.6142	11.6
R95012.6	—	12.60	0.4961	9.4	R95015.7	—	15.70	0.6181	11.6
R9501/2	1/2	12.70	0.5000	9.4	R9505/8	5/8	15.88	0.6250	11.6
R95012.8	—	12.80	0.5039	9.4	R95016.0	—	16.00	0.6299	11.6
R95012.9	—	12.90	0.5079	9.4	R95016.08	—	16.08	0.6331	11.6
R95013.0	—	13.00	0.5118	9.7	R95016.1	—	16.10	0.6339	11.6
R95033/64	33/64	13.10	0.5156	9.7	R95016.2	—	16.20	0.6378	11.6
R95013.2	—	13.20	0.5197	9.7	R95041/64	41/64	16.27	0.6406	11.6
R95017/32	17/32	13.49	0.5313	9.7	R95016.3	—	16.30	0.6417	11.6
R95013.5	—	13.50	0.5315	10.3	R95016.5	—	16.50	0.6496	11.6
R95013.6	—	13.60	0.5354	10.3	R95016.6	—	16.60	0.6535	12.2
R95013.7	—	13.70	0.5394	10.3	R95021/32	21/32	16.67	0.6563	12.2
R95013.8	—	13.80	0.5433	10.3	R95016.7	—	16.70	0.6575	12.2
R95035/64	35/64	13.89	0.5469	10.3	R95017.0	—	17.00	0.6693	12.2
R95014.0	—	14.00	0.5512	10.3	R95043/64	43/64	17.07	0.6719	12.2
R95014.1	—	14.10	0.5551	10.3	R95017.1	—	17.10	0.6732	12.2
R95014.2	—	14.20	0.5591	10.3	R95017.2	—	17.20	0.6772	12.2
R9509/16	9/16	14.29	0.5625	10.3	R95011/16	11/16	17.46	0.6875	12.2
R95014.5	—	14.50	0.5709	10.3	R95017.5	—	17.50	0.6890	12.2
R95014.6	—	14.60	0.5748	11.0	R95017.6	—	17.60	0.6929	12.9
R95037/64	37/64	14.68	0.5781	11.0	R95017.7	—	17.70	0.6969	12.9
R95014.7	—	14.70	0.5787	11.0	R95045/64	45/64	17.86	0.7031	12.9
R95014.8	—	14.80	0.5827	11.0	R95018.0	—	18.00	0.7087	12.9
R95015.0	—	15.00	0.5906	11.0	R95018.1	—	18.10	0.7126	12.9
R95019/32	19/32	15.08	0.5938	11.0	R95018.2	—	18.20	0.7165	12.9



Produit	DC	DC	DC	LH
	(inch)	(mm)	(inch)	(mm)
R95023/32	23/32	18.26	0.7188	12.9
R95018.5	–	18.50	0.7283	12.9
R95018.6	–	18.60	0.7323	13.5
R95047/64	47/64	18.65	0.7344	13.5
R95018.7	–	18.70	0.7362	13.5
R95018.9	–	18.90	0.7441	13.5
R95019.0	–	19.00	0.7480	13.5
R9503/4	3/4	19.05	0.7500	13.5
R95019.1	–	19.10	0.7520	13.5
R95019.2	–	19.20	0.7559	13.5
R95019.25	–	19.25	0.7579	13.5
R95019.3	–	19.30	0.7598	13.5
R95019.35	–	19.35	0.7618	13.5
R95049/64	49/64	19.45	0.7656	13.5
R95019.5	–	19.50	0.7677	13.5
R95019.6	–	19.60	0.7717	14.1
R95019.7	–	19.70	0.7756	14.1
R95025/32	25/32	19.84	0.7813	14.1
R95020.0	–	20.00	0.7874	14.1
R95051/64	51/64	20.24	0.7969	14.1
R95020.5	–	20.50	0.8071	14.1
R95013/16	13/16	20.64	0.8125	14.8
R95021.0	–	21.00	0.8268	14.8
R95053/64	53/64	21.03	0.8281	14.8
R95027/32	27/32	21.43	0.8438	14.8
R95021.5	–	21.50	0.8465	14.8
R95055/64	55/64	21.83	0.8594	15.0
R95022.0	–	22.00	0.8661	15.0
R9507/8	7/8	22.22	0.8750	15.0
R95022.5	–	22.50	0.8858	15.0
R95057/64	57/64	22.62	0.8906	15.0
R95022.7	–	22.70	0.8937	15.0
R95023.0	–	23.00	0.9055	15.1
R95029/32	29/32	23.02	0.9063	15.1
R95059/64	59/64	23.42	0.9219	15.1
R95023.5	–	23.50	0.9252	15.1
R95015/16	15/16	23.81	0.9375	15.4
R95024.0	–	24.00	0.9449	15.4
R95061/64	61/64	24.21	0.9531	15.4
R95024.5	–	24.50	0.9646	15.4
R95031/32	31/32	24.61	0.9688	15.4
R95025.0	–	25.00	0.9844	15.8
R95063/64	63/64	25.00	0.9844	15.8
R9501	1"	25.40	1.0000	15.8
R95025.5	–	25.50	1.0039	15.8
R95025.6	–	25.60	1.0079	15.8
R95025.65	–	25.65	1.0098	15.8
R9501.1/64	1.1/64	25.80	1.0156	15.8
R95026.0	–	26.00	1.0236	16.4
R9501.1/32	1.1/32	26.19	1.0313	16.4

Produit	DC	DC	DC	LH
	(inch)	(mm)	(inch)	(mm)
R95026.5	–	26.50	1.0433	16.4
R9501.3/64	1.3/64	26.59	1.0469	16.4
R9501.1/16	1.1/16	26.99	1.0625	17.1
R95027.0	–	27.00	1.0630	17.1
R9501.5/64	1.5/64	27.38	1.0781	17.1
R95027.5	–	27.50	1.0827	17.1
R9501.3/32	1.3/32	27.78	1.0938	17.1
R95028.0	–	28.00	1.1024	17.7
R9501.7/64	1.7/64	28.18	1.1094	17.7
R95028.5	–	28.50	1.1220	17.7
R9501.1/8	1.1/8	28.58	1.1250	17.7
R9501.9/64	1.9/64	28.97	1.1406	18.3
R95029.0	–	29.00	1.1417	18.3
R9501.5/32	1.5/32	29.37	1.1563	18.3
R95029.5	–	29.50	1.1614	18.3
R9501.11/64	1.11/64	29.77	1.1719	18.3
R95030.0	–	30.00	1.1811	19.0
R9501.3/16	1.3/16	30.16	1.1875	19.0
R95030.5	–	30.50	1.2008	19.0
R9501.7/32	1.7/32	30.96	1.2188	21.0
R95031.0	–	31.00	1.2205	21.0
R9501.1/4	1.1/4	31.75	1.2500	21.0
R95032.0	–	32.00	1.2598	21.0
R95032.5	–	32.50	1.2795	21.0
R9501.19/64	1.19/64	32.94	1.2969	21.0
R95033.0	–	33.00	1.2992	21.0
R95033.5	–	33.50	1.3189	21.0
R95034.0	–	34.00	1.3386	23.0
R9501.11/32	1.11/32	34.13	1.3438	23.0
R95034.5	–	34.50	1.3583	23.0
R9501.3/8	1.3/8	34.93	1.3750	23.0
R95035.0	–	35.00	1.3780	23.0
R95036.0	–	36.00	1.4173	23.0
R9501.27/64	1.27/64	36.12	1.4219	23.0
R95036.5	–	36.50	1.4370	23.0
R95037.0	–	37.00	1.4567	25.0
R9501.15/32	1.15/32	37.31	1.4688	25.0
R95037.5	–	37.50	1.4764	25.0
R95038.0	–	38.00	1.4961	25.0
R9501.1/2	1.1/2	38.10	1.5000	25.0
R95038.5	–	38.50	1.5157	25.0
R9501.17/32	1.17/32	38.89	1.5313	25.0
R95039.0	–	39.00	1.5354	25.0
R95039.5	–	39.50	1.5551	25.0
R9501.9/16	1.9/16	39.69	1.5625	27.0
R95040.0	–	40.00	1.5748	27.0
R95041.0	–	41.00	1.6142	27.0
R9501.5/8	1.5/8	41.28	1.6250	27.0
R95042.0	–	42.00	1.6535	27.0



R960



Tête de perçage HYDRA pour aciers inoxydables, revêtement Ti-phon

Tête interchangeable précise (tolérance de la tête h7) pour des performances élevées dans les aciers inoxydables. Un affûtage en croix à 140° facilite l'autocentrage et réduit les forces de coupe. Le revêtement Ti-phon empêche le phénomène d'arête rapportée et améliore considérablement le glissement des copeaux, avec une résistance à l'usure et une solidité des arêtes supérieures.

HYDRA

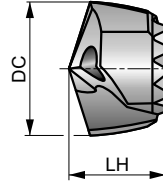

HM	DORMER	140°
Ti-phon	R	
DC h7		

H851	Appliquer les valeurs de vitesse et d'avance initiales avec un facteur de correction de 1.10
H853	Appliquer les valeurs de vitesse et d'avance initiales avec un facteur de correction de 1.00
H855	Appliquer les valeurs de vitesse et d'avance initiales avec un facteur de correction de 0.95
H858	Appliquer les valeurs de vitesse et d'avance initiales avec un facteur de correction de 0.90
H8512	Appliquer les valeurs de vitesse et d'avance initiales avec un facteur de correction de 0.80

Adéquation du groupe de matériaux de la pièce, valeurs de départ pour la vitesse de coupe (m/min) et code Alpha d'avance.

P1.1	P1.2	P1.3	P2.1	M1.1	M1.2	M2.1	M2.2	M2.3	M3.1	M3.2	M3.3	M4.1	M4.2
■ 133 W	■ 148 W	■ 154 W	■ 114 W	■ 82 V	■ 70 V	■ 73 V	■ 60 V	▣ 50 T	■ 58 T	■ 50 T	■ 45 T	■ 40 T	▣ 34 T
K1.1	K1.2	K1.3	K2.1	K2.2	K2.3	K3.1	K3.2	K3.3	K4.1	K4.2	K4.3	K4.4	K4.5
■ 120 V	■ 89 V	■ 67 V	▣ 108 V	▣ 88 V	▣ 70 V	▣ 96 V	▣ 73 V	▣ 59 V	▣ 89 V	▣ 67 V	▣ 49 V	▣ 42 V	▣ 35 V
K5.1	K5.2	K5.3	S1.1	S1.2	S1.3	S2.1	S2.2	S3.1	S3.2	S4.1	S4.2		
▣ 100 V	▣ 76 V	▣ 58 V	▣ 45 T	▣ 35 T	▣ 30 S	▣ 40 S	▣ 35 S	▣ 30 S	▣ 25 S	▣ 23 S	▣ 20 S		

Produit	DC	DC	DC	LH
	(inch)	(mm)	(inch)	(mm)
R96015/32	15/32	11.91	0.4688	9.1
R96012.0	—	12.00	0.4724	9.1
R96012.1	—	12.10	0.4764	9.1
R96012.2	—	12.20	0.4803	9.1
R96031/64	31/64	12.30	0.4844	9.1
R96012.5	—	12.50	0.4921	9.4
R96012.6	—	12.60	0.4961	9.4
R9601/2	1/2	12.70	0.5000	9.4
R96012.8	—	12.80	0.5039	9.4
R96012.9	—	12.90	0.5079	9.4
R96013.0	—	13.00	0.5118	9.7
R96033/64	33/64	13.10	0.5156	9.7
R96013.2	—	13.20	0.5197	9.7
R96017/32	17/32	13.49	0.5313	9.7
R96013.5	—	13.50	0.5315	10.3
R96013.6	—	13.60	0.5354	10.3
R96013.7	—	13.70	0.5394	10.3
R96013.8	—	13.80	0.5433	10.3
R96035/64	35/64	13.89	0.5469	10.3
R96014.0	—	14.00	0.5512	10.3
R96014.1	—	14.10	0.5551	10.3
R96014.2	—	14.20	0.5591	10.3
R9609/16	9/16	14.29	0.5625	10.3
R96014.5	—	14.50	0.5709	10.3
R96014.6	—	14.60	0.5748	11.0
R96037/64	37/64	14.68	0.5781	11.0
R96014.7	—	14.70	0.5787	11.0
R96014.8	—	14.80	0.5827	11.0

Produit	DC	DC	DC	LH
	(inch)	(mm)	(inch)	(mm)
R96015.0	—	15.00	0.5906	11.0
R96019/32	19/32	15.08	0.5938	11.0
R96015.1	—	15.10	0.5945	11.0
R96015.2	—	15.20	0.5984	11.0
R96015.24	—	15.24	0.6000	11.0
R96039/64	39/64	15.48	0.6094	11.0
R96015.5	—	15.50	0.6102	11.0
R96015.6	—	15.60	0.6142	11.6
R96015.7	—	15.70	0.6181	11.6
R9605/8	5/8	15.88	0.6250	11.6
R96016.0	—	16.00	0.6299	11.6
R96016.08	—	16.08	0.6331	11.6
R96016.1	—	16.10	0.6339	11.6
R96016.2	—	16.20	0.6378	11.6
R96041/64	41/64	16.27	0.6406	11.6
R96016.3	—	16.30	0.6417	11.6
R96016.5	—	16.50	0.6496	11.6
R96016.6	—	16.60	0.6535	12.2
R96021/32	21/32	16.67	0.6563	12.2
R96016.7	—	16.70	0.6575	12.2
R96017.0	—	17.00	0.6693	12.2
R96043/64	43/64	17.07	0.6719	12.2
R96017.1	—	17.10	0.6732	12.2
R96017.2	—	17.20	0.6772	12.2
R96011/16	11/16	17.46	0.6875	12.2
R96017.5	—	17.50	0.6890	12.2
R96017.6	—	17.60	0.6929	12.9
R96017.7	—	17.70	0.6969	12.9



Produit	DC	DC	DC	LH
	(inch)	(mm)	(inch)	(mm)
R96045/64	45/64	17.86	0.7031	12.9
R96018.0	–	18.00	0.7087	12.9
R96018.1	–	18.10	0.7126	12.9
R96018.2	–	18.20	0.7165	12.9
R96023/32	23/32	18.26	0.7188	12.9
R96018.5	–	18.50	0.7283	12.9
R96018.6	–	18.60	0.7323	13.5
R96047/64	47/64	18.65	0.7344	13.5
R96018.7	–	18.70	0.7362	13.5
R96018.9	–	18.90	0.7441	13.5
R96019.0	–	19.00	0.7480	13.5
R9603/4	3/4	19.05	0.7500	13.5
R96019.1	–	19.10	0.7520	13.5
R96019.2	–	19.20	0.7559	13.5
R96019.25	–	19.25	0.7579	13.5
R96019.3	–	19.30	0.7598	13.5
R96019.35	–	19.35	0.7618	13.5
R96049/64	49/64	19.45	0.7656	13.5
R96019.5	–	19.50	0.7677	13.5
R96019.6	–	19.60	0.7717	14.1
R96019.7	–	19.70	0.7756	14.1
R96025/32	25/32	19.84	0.7813	14.1
R96020.0	–	20.00	0.7874	14.1
R96051/64	51/64	20.24	0.7969	14.1
R96020.5	–	20.50	0.8071	14.1
R96013/16	13/16	20.64	0.8125	14.8
R96021.0	–	21.00	0.8268	14.8
R96053/64	53/64	21.03	0.8281	14.8
R96027/32	27/32	21.43	0.8438	14.8
R96021.5	–	21.50	0.8465	14.8
R96055/64	55/64	21.83	0.8594	15.0
R96022.0	–	22.00	0.8661	15.0
R9607/8	7/8	22.22	0.8750	15.0
R96022.5	–	22.50	0.8858	15.0
R96057/64	57/64	22.62	0.8906	15.0
R96022.7	–	22.70	0.8937	15.0

Produit	DC	DC	DC	LH
	(inch)	(mm)	(inch)	(mm)
R96023.0	–	23.00	0.9055	15.1
R96029/32	29/32	23.02	0.9063	15.1
R96059/64	59/64	23.42	0.9219	15.1
R96023.5	–	23.50	0.9252	15.1
R96015/16	15/16	23.81	0.9375	15.4
R96024.0	–	24.00	0.9449	15.4
R96061/64	61/64	24.21	0.9531	15.4
R96024.5	–	24.50	0.9646	15.4
R96031/32	31/32	24.61	0.9688	15.4
R96025.0	–	25.00	0.9844	15.8
R96063/64	63/64	25.00	0.9844	15.8
R9601	1"	25.40	1.0000	15.8
R96025.5	–	25.50	1.0039	15.8
R96025.65	–	25.65	1.0098	15.8
R9601.1/64	1.1/64	25.80	1.0156	15.8
R96026.0	–	26.00	1.0236	16.4
R9601.1/32	1.1/32	26.19	1.0313	16.4
R96026.5	–	26.50	1.0433	16.4
R9601.3/64	1.3/64	26.59	1.0469	16.4
R9601.1/16	1.1/16	26.99	1.0625	17.1
R96027.0	–	27.00	1.0630	17.1
R9601.5/64	1.5/64	27.38	1.0781	17.1
R96027.5	–	27.50	1.0827	17.1
R9601.3/32	1.3/32	27.78	1.0938	17.1
R96028.0	–	28.00	1.1024	17.7
R9601.7/64	1.7/64	28.18	1.1094	17.7
R96028.5	–	28.50	1.1220	17.7
R9601.1/8	1.1/8	28.58	1.1250	17.7
R9601.9/64	1.9/64	28.97	1.1406	18.3
R96029.0	–	29.00	1.1417	18.3
R9601.5/32	1.5/32	29.37	1.1563	18.3
R96029.5	–	29.50	1.1614	18.3
R9601.11/64	1.11/64	29.77	1.1719	18.3
R96030.0	–	30.00	1.1811	19.0
R9601.3/16	1.3/16	30.16	1.1875	19.0
R96030.5	–	30.50	1.2008	19.0



R970

DORMER



Tête de perçage HYDRA pour les fontes, revêtement Ti-phon

Tête interchangeable précise (tolérance de la tête h7) pour des performances élevées dans les fontes. Un affûtage en croix à 140° facilite l'autocentrage et réduit les forces de coupe. Le revêtement Ti-phon empêche le phénomène d'arête rapportée et améliore considérablement le glissement des copeaux, avec une résistance à l'usure et une solidité des arêtes supérieures.

HYDRA

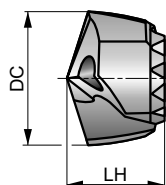

HM	DORMER	140°
Ti-phon	R	
DC h7		

H851	Appliquer les valeurs de vitesse et d'avance initiales avec un facteur de correction de 1.10
H853	Appliquer les valeurs de vitesse et d'avance initiales avec un facteur de correction de 1.00
H855	Appliquer les valeurs de vitesse et d'avance initiales avec un facteur de correction de 0.95
H858	Appliquer les valeurs de vitesse et d'avance initiales avec un facteur de correction de 0.90
H8512	Appliquer les valeurs de vitesse et d'avance initiales avec un facteur de correction de 0.80

Adéquation du groupe de matériaux de la pièce, valeurs de départ pour la vitesse de coupe (m/min) et code Alpha d'avance.

K1.1 ■ 120 V	K1.2 ■ 89 V	K1.3 ■ 67 V	K2.1 ■ 98 V	K2.2 ■ 80 V	K2.3 ■ 64 V	K3.1 ■ 97 V	K3.2 ■ 67 V	K3.3 ■ 54 V	K4.1 ■ 81 V	K4.2 ■ 61 V	K4.3 ■ 45 V	K4.4 ■ 38 V	K4.5 ■ 32 V
K5.1 ■ 91 V	K5.2 ■ 69 V	K5.3 ■ 53 V											

Produit	DC	DC	DC	LH
	(inch)	(mm)	(inch)	(mm)
R97015/32	15/32	11.91	0.4688	9.1
R97012.0	—	12.00	0.4724	9.1
R97012.1	—	12.10	0.4764	9.1
R97012.2	—	12.20	0.4803	9.1
R97031/64	31/64	12.30	0.4844	9.1
R97012.5	—	12.50	0.4921	9.4
R97012.6	—	12.60	0.4961	9.4
R9701/2	1/2	12.70	0.5000	9.4
R97012.8	—	12.80	0.5039	9.4
R97012.9	—	12.90	0.5079	9.4
R97013.0	—	13.00	0.5118	9.7
R97033/64	33/64	13.10	0.5156	9.7
R97013.2	—	13.20	0.5197	9.7
R97017/32	17/32	13.49	0.5313	9.7
R97013.5	—	13.50	0.5315	10.3
R97013.6	—	13.60	0.5354	10.3
R97013.7	—	13.70	0.5394	10.3
R97013.8	—	13.80	0.5433	10.3
R97035/64	35/64	13.89	0.5469	10.3
R97014.0	—	14.00	0.5512	10.3
R97014.1	—	14.10	0.5551	10.3
R97014.2	—	14.20	0.5591	10.3
R9709/16	9/16	14.29	0.5625	10.3
R97014.5	—	14.50	0.5709	10.3
R97014.6	—	14.60	0.5748	11.0
R97037/64	37/64	14.68	0.5781	11.0
R97014.7	—	14.70	0.5787	11.0
R97014.8	—	14.80	0.5827	11.0
R97015.0	—	15.00	0.5906	11.0
R97019/32	19/32	15.08	0.5938	11.0

Produit	DC	DC	DC	LH
	(inch)	(mm)	(inch)	(mm)
R97015.1	—	15.10	0.5945	11.0
R97015.2	—	15.20	0.5984	11.0
R97015.24	—	15.24	0.6000	11.0
R97039/64	39/64	15.48	0.6094	11.0
R97015.5	—	15.50	0.6102	11.0
R97015.6	—	15.60	0.6142	11.6
R97015.7	—	15.70	0.6181	11.6
R9705/8	5/8	15.88	0.6250	11.6
R97016.0	—	16.00	0.6299	11.6
R97016.08	—	16.08	0.6331	11.6
R97016.1	—	16.10	0.6339	11.6
R97016.2	—	16.20	0.6378	11.6
R97041/64	41/64	16.27	0.6406	11.6
R97016.3	—	16.30	0.6417	11.6
R97016.5	—	16.50	0.6496	11.6
R97016.6	—	16.60	0.6535	12.2
R97021/32	21/32	16.67	0.6563	12.2
R97016.7	—	16.70	0.6575	12.2
R97017.0	—	17.00	0.6693	12.2
R97043/64	43/64	17.07	0.6719	12.2
R97017.1	—	17.10	0.6732	12.2
R97017.2	—	17.20	0.6772	12.2
R97011/16	11/16	17.46	0.6875	12.2
R97017.5	—	17.50	0.6890	12.2
R97017.6	—	17.60	0.6929	12.9
R97017.7	—	17.70	0.6969	12.9
R97045/64	45/64	17.86	0.7031	12.9
R97018.0	—	18.00	0.7087	12.9
R97018.1	—	18.10	0.7126	12.9
R97018.2	—	18.20	0.7165	12.9



Produit	DC	DC	DC	LH
	(inch)	(mm)	(inch)	(mm)
R97023/32	23/32	18.26	0.7188	12.9
R97018.5	–	18.50	0.7283	12.9
R97018.6	–	18.60	0.7323	13.5
R97047/64	47/64	18.65	0.7344	13.5
R97018.7	–	18.70	0.7362	13.5
R97018.9	–	18.90	0.7441	13.5
R97019.0	–	19.00	0.7480	13.5
R9703/4	3/4	19.05	0.7500	13.5
R97019.1	–	19.10	0.7520	13.5
R97019.2	–	19.20	0.7559	13.5
R97019.25	–	19.25	0.7579	13.5
R97019.3	–	19.30	0.7598	13.5
R97019.35	–	19.35	0.7618	13.5
R97049/64	49/64	19.45	0.7656	13.5
R97019.5	–	19.50	0.7677	13.5
R97019.6	–	19.60	0.7717	14.1
R97019.7	–	19.70	0.7756	14.1
R97025/32	25/32	19.84	0.7813	14.1
R97020.0	–	20.00	0.7874	14.1
R97051/64	51/64	20.24	0.7969	14.1
R97020.5	–	20.50	0.8071	14.1
R97013/16	13/16	20.64	0.8125	14.8
R97021.0	–	21.00	0.8268	14.8
R97053/64	53/64	21.03	0.8281	14.8
R97027/32	27/32	21.43	0.8438	14.8
R97021.5	–	21.50	0.8465	14.8
R97055/64	55/64	21.83	0.8594	15.0
R97022.0	–	22.00	0.8661	15.0
R9707/8	7/8	22.22	0.8750	15.0
R97022.5	–	22.50	0.8858	15.0
R97057/64	57/64	22.62	0.8906	15.0
R97022.7	–	22.70	0.8937	15.0
R97023.0	–	23.00	0.9055	15.1
R97029/32	29/32	23.02	0.9063	15.1
R97059/64	59/64	23.42	0.9219	15.1
R97023.5	–	23.50	0.9252	15.1
R97015/16	15/16	23.81	0.9375	15.4
R97024.0	–	24.00	0.9449	15.4
R97061/64	61/64	24.21	0.9531	15.4
R97024.5	–	24.50	0.9646	15.4
R97031/32	31/32	24.61	0.9688	15.4
R97025.0	–	25.00	0.9844	15.8
R97063/64	63/64	25.00	0.9844	15.8
R9701	1"	25.40	1.0000	15.8
R97025.5	–	25.50	1.0039	15.8
R97025.65	–	25.65	1.0098	15.8
R9701.1/64	1.1/64	25.80	1.0156	15.8
R97026.0	–	26.00	1.0236	16.4
R9701.1/32	1.1/32	26.19	1.0313	16.4

Produit	DC	DC	DC	LH
	(inch)	(mm)	(inch)	(mm)
R97026.5	–	26.50	1.0433	16.4
R9701.3/64	1.3/64	26.59	1.0469	16.4
R9701.1/16	1.1/16	26.99	1.0625	17.1
R97027.0	–	27.00	1.0630	17.1
R9701.5/64	1.5/64	27.38	1.0781	17.1
R97027.5	–	27.50	1.0827	17.1
R9701.3/32	1.3/32	27.78	1.0938	17.1
R97028.0	–	28.00	1.1024	17.7
R9701.7/64	1.7/64	28.18	1.1094	17.7
R97028.5	–	28.50	1.1220	17.7
R9701.1/8	1.1/8	28.58	1.1250	17.7
R9701.9/64	1.9/64	28.97	1.1406	18.3
R97029.0	–	29.00	1.1417	18.3
R9701.5/32	1.5/32	29.37	1.1563	18.3
R97029.5	–	29.50	1.1614	18.3
R9701.11/64	1.11/64	29.77	1.1719	18.3
R97030.0	–	30.00	1.1811	19.0
R9701.3/16	1.3/16	30.16	1.1875	19.0
R97030.5	–	30.50	1.2008	19.0
R9701.7/32	1.7/32	30.96	1.2188	21.0
R97031.0	–	31.00	1.2205	21.0
R9701.1/4	1.1/4	31.75	1.2500	21.0
R97032.0	–	32.00	1.2598	21.0
R97032.5	–	32.50	1.2795	21.0
R9701.19/64	1.19/64	32.94	1.2969	21.0
R97033.0	–	33.00	1.2992	21.0
R97033.5	–	33.50	1.3189	21.0
R97034.0	–	34.00	1.3386	23.0
R9701.11/32	1.11/32	34.13	1.3438	23.0
R97034.5	–	34.50	1.3583	23.0
R9701.3/8	1.3/8	34.93	1.3750	23.0
R97035.0	–	35.00	1.3780	23.0
R97036.0	–	36.00	1.4173	23.0
R9701.27/64	1.27/64	36.12	1.4219	23.0
R97036.5	–	36.50	1.4370	23.0
R97037.0	–	37.00	1.4567	25.0
R9701.15/32	1.15/32	37.31	1.4688	25.0
R97037.5	–	37.50	1.4764	25.0
R97038.0	–	38.00	1.4961	25.0
R9701.1/2	1.1/2	38.10	1.5000	25.0
R97038.5	–	38.50	1.5157	25.0
R9701.17/32	1.17/32	38.89	1.5313	25.0
R97039.0	–	39.00	1.5354	25.0
R97039.5	–	39.50	1.5551	25.0
R9701.9/16	1.9/16	39.69	1.5625	27.0
R97040.0	–	40.00	1.5748	27.0
R97041.0	–	41.00	1.6142	27.0
R9701.5/8	1.5/8	41.28	1.6250	27.0
R97042.0	–	42.00	1.6535	27.0

NEW**H851****DORMER**

Corps HYDRA 1,5XD, avec arrosage centralisé, nickelage brillant

Corps utilisable avec les têtes R950, R960 et R970 HYDRA. Une gamme de diamètres de tête peut être utilisée avec le même corps. Les trous d'arrosage centralisé alignés avec les têtes offrent un refroidissement efficace. La queue épaulée empêche le foret de se déplacer dans l'attachement. La surface nickelée protège de la corrosion et améliore l'évacuation des copeaux.

HYDRA

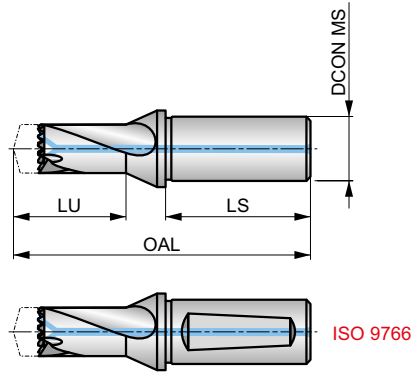

HSS	DORMER	1.5×D
Bright Ni	ISO 9766	R

Quatre (4) vis et un (1) tournevis sont livrés avec le corps du foret, DCON MS tolérance h6.

Produit	DCONMS	DCON MS	LU	OAL	LS	ADINTMS
	(inch)	(mm)	(mm)	(mm)	(mm)	
H85131/64	5/8	15.88	25.50	88.5	47.6	Cylindrical
H8511/2	5/8	15.88	25.80	88.8	47.6	Cylindrical
H85117/32	5/8	15.88	30.90	93.9	47.6	Cylindrical
H85112.0	—	16.00	25.50	88.5	48.0	ISO 9766
H85112.5	—	16.00	25.80	88.8	48.0	ISO 9766
H85113.0	—	16.00	27.00	90.0	48.0	ISO 9766
H85114.0	—	16.00	30.90	93.9	48.0	ISO 9766
H8519/16	3/4	19.05	30.30	93.9	50.8	Cylindrical
H85139/64	3/4	19.05	32.30	97.3	50.8	Cylindrical
H85141/64	3/4	19.05	34.90	99.9	50.8	Cylindrical
H85111/16	3/4	19.05	36.40	101.4	50.8	Cylindrical
H85123/32	3/4	19.05	39.00	104.0	50.8	Cylindrical
H85115.0	—	20.00	32.30	97.3	50.0	ISO 9766
H85116.0	—	20.00	34.90	99.9	50.0	ISO 9766
H85117.0	—	20.00	36.40	101.4	50.0	ISO 9766
H85118.0	—	20.00	39.00	104.0	50.0	ISO 9766
H85119.0	—	25.00	40.40	111.4	56.0	ISO 9766
H85120.0	—	25.00	43.00	114.0	56.0	ISO 9766
H85121.0	—	25.00	44.50	115.5	56.0	ISO 9766
H85122.0	—	25.00	46.10	117.1	56.0	ISO 9766
H85123.0	—	25.00	47.00	118.0	56.0	ISO 9766
H85149/64	1"	25.40	40.40	111.4	57.1	Cylindrical
H85151/64	1"	25.40	43.00	114.0	57.1	Cylindrical
H85127/32	1"	25.40	44.50	115.5	57.1	Cylindrical
H85157/64	1"	25.40	46.10	117.1	57.1	Cylindrical
H85159/64	1"	25.40	47.00	118.0	57.1	Cylindrical
H85131/32	1"	25.40	49.30	124.3	57.1	Cylindrical
H8511.1/64	1.1/4	31.75	49.70	124.7	60.3	Cylindrical
H8511.3/64	1.1/4	31.75	52.30	127.3	60.3	Cylindrical
H8511.3/32	1.1/4	31.75	52.80	127.8	60.3	Cylindrical
H8511.1/8	1.1/4	31.75	54.40	129.4	60.3	Cylindrical
H8511.11/64	1.1/4	31.75	55.80	130.8	60.3	Cylindrical
H8511.3/16	1.1/4	31.75	58.40	133.4	60.3	Cylindrical
H85124.0	—	32.00	49.30	124.3	60.0	ISO 9766



Produit	DCONMS	DCON MS	LU	OAL	LS	ADINTMS
	(inch)	(mm)	(mm)	(mm)	(mm)	
H85125.0	–	32.00	49.70	124.7	60.0	ISO 9766
H85126.0	–	32.00	52.30	127.3	60.0	ISO 9766
H85127.0	–	32.00	52.80	127.8	60.0	ISO 9766
H85128.0	–	32.00	54.40	129.4	60.0	ISO 9766
H85129.0	–	32.00	55.80	130.8	60.0	ISO 9766
H85130.0	–	32.00	58.40	133.4	60.0	ISO 9766



H853



Corps HYDRA 3XD, avec arrosage centralisé, nickelage brillant

Corps utilisable avec les têtes R950, R960 et R970 HYDRA. Une gamme de diamètres de tête peut être utilisée avec le même corps. Les trous d'arrosage centralisé alignés avec les têtes offrent un refroidissement efficace. La surface nickelée brillante protège de la corrosion et améliore l'évacuation des copeaux.

HYDRA

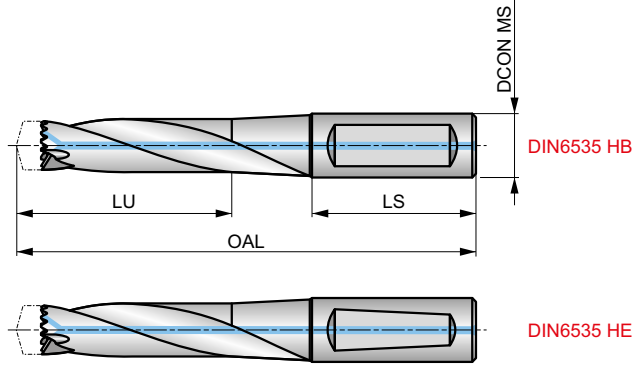

HSS	DORMER	3xD
Bright Ni	DIN 6535HB DIN 6535HE	R

Quatre (4) vis et un (1) tournevis sont livrés avec le corps du foret, DCON MS tolérance h6.

Produit	DCONMS	DCON MS	LU	OAL	LS	ADINTMS
	(inch)	(mm)	(mm)	(mm)	(mm)	
H85312.0	–	16.00	44.00	105.0	48.0	DIN6535HE
H85331/64	5/8	15.88	44.00	105.0	48.0	DIN6535HB
H85312.5	–	16.00	44.00	105.0	48.0	DIN6535HE
H8531/2	5/8	15.88	44.00	105.0	48.0	DIN6535HB
H85313.0	–	16.00	47.00	110.0	48.0	DIN6535HE
H85317/32	5/8	15.88	47.00	110.0	48.0	DIN6535HB
H85314.0	–	16.00	52.50	116.5	48.0	DIN6535HE
H8539/16	3/4	19.05	52.50	116.5	48.0	DIN6535HB
H85315.0	–	20.00	55.50	126.5	50.0	DIN6535HE
H85339/64	3/4	19.05	55.50	126.5	50.0	DIN6535HB
H85316.0	–	20.00	59.50	131.5	50.0	DIN6535HE
H85341/64	3/4	19.05	59.50	131.5	50.0	DIN6535HB
H85317.0	–	20.00	62.50	136.5	50.0	DIN6535HE
H85311/16	3/4	19.05	62.50	136.5	50.0	DIN6535HB
H85318.0	–	20.00	66.50	141.5	50.0	DIN6535HE
H85323/32	3/4	19.05	66.50	141.5	50.0	DIN6535HB
H85319.0	–	25.00	69.50	156.5	56.0	DIN6535HE
H85349/64	1"	25.40	69.50	156.5	56.0	DIN6535HB
H85320.0	–	25.00	73.50	156.5	56.0	DIN6535HE
H85351/64	1"	25.40	73.50	156.5	56.0	DIN6535HB
H85321.0	–	25.00	76.50	156.5	56.0	DIN6535HE
H85327/32	1"	25.40	76.50	156.5	56.0	DIN6535HB
H85322.0	–	25.00	80.10	161.5	56.0	DIN6535HE
H85357/64	1"	25.40	80.10	161.5	56.0	DIN6535HB
H85323.0	–	25.00	82.50	160.5	56.0	DIN6535HE
H85359/64	1"	25.40	82.50	160.5	56.0	DIN6535HB
H85324.0	–	32.00	86.20	170.2	60.0	DIN6535HE
H85331/32	1"	25.40	86.20	170.2	60.0	DIN6535HB
H85325.0	–	32.00	88.00	170.0	60.0	DIN6535HE
H8531.1/64	1.1/4	31.75	88.00	170.0	60.0	DIN6535HB
H85326.0	–	32.00	92.00	175.0	60.0	DIN6535HE
H8531.3/64	1.1/4	31.75	92.00	175.0	60.0	DIN6535HB
H85327.0	–	32.00	94.00	175.0	60.0	DIN6535HE
H8531.3/32	1.1/4	31.75	94.00	175.0	60.0	DIN6535HB



Produit	DCONMS	DCON MS	LU	OAL	LS	ADINTMS
	(inch)	(mm)	(mm)	(mm)	(mm)	
H85328.0	–	32.00	97.00	180.0	60.0	DIN6535HE
H8531.1/8	1.1/4	31.75	97.00	180.0	60.0	DIN6535HB
H85329.0	–	32.00	100.00	185.0	60.0	DIN6535HE
H8531.11/64	1.1/4	31.75	100.00	185.0	60.0	DIN6535HB
H85330.0	–	32.00	104.00	185.0	60.0	DIN6535HE
H8531.3/16	1.1/4	31.75	104.00	185.0	60.0	DIN6535HB
H85332.0	–	32.00	111.50	196.5	60.0	DIN6535HE
H85333.5	–	32.00	116.50	201.5	60.0	DIN6535HE
H85335.0	–	40.00	121.50	216.5	70.0	DIN6535HB
H85336.5	–	40.00	125.50	221.5	70.0	DIN6535HB
H85338.0	–	40.00	131.50	226.5	70.0	DIN6535HB
H85339.5	–	40.00	136.50	231.5	70.0	DIN6535HB
H85341.0	–	40.00	146.50	246.5	70.0	DIN6535HB
H85342.5	–	40.00	151.60	251.6	70.0	DIN6535HB



H855



Corps HYDRA 5XD, avec arrosage centralisé, nickelage brillant

Corps utilisable avec les têtes R950, R960 et R970 HYDRA. Une gamme de diamètres de tête peut être utilisée avec le même corps. Les trous d'arrosage centralisé alignés avec les têtes offrent un refroidissement efficace. La surface nickelée brillante protège de la corrosion et améliore l'évacuation des copeaux.

HYDRA

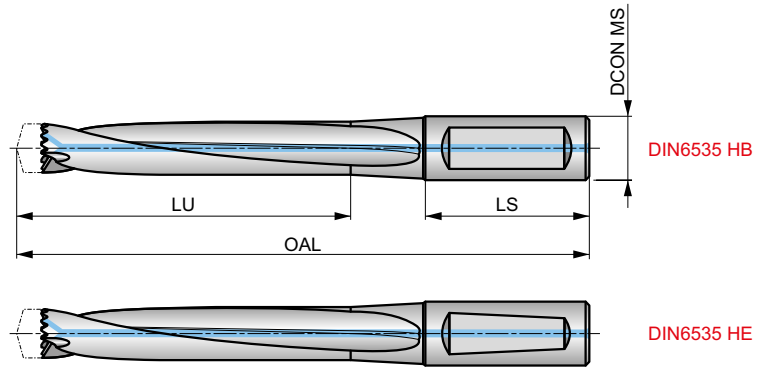

HSS	DORMER	5xD
Bright Ni	DIN 6535HB DIN 6535HE	R

Quatre (4) vis et un (1) tournevis sont livrés avec le corps du foret, DCON MS tolérance h6.

Produit	DCONMS	DCON MS	LU	OAL	LS	ADINTMS
	(inch)	(mm)	(mm)	(mm)	(mm)	
H85512.0	–	16.00	69.00	130.0	48.0	DIN6535HE
H85531/64	5/8	15.88	69.00	130.0	48.0	DIN6535HB
H85512.5	–	16.00	69.00	130.0	48.0	DIN6535HE
H8551/2	5/8	15.88	69.00	130.0	48.0	DIN6535HB
H85513.0	–	16.00	74.00	140.0	48.0	DIN6535HE
H85517/32	5/8	15.88	74.00	140.0	48.0	DIN6535HB
H85514.0	–	16.00	81.50	146.5	48.0	DIN6535HE
H8559/16	3/4	19.05	81.50	146.5	48.0	DIN6535HB
H85515.0	–	20.00	86.50	156.5	50.0	DIN6535HE
H85539/64	3/4	19.05	86.50	156.5	50.0	DIN6535HB
H85516.0	–	20.00	92.50	166.5	50.0	DIN6535HE
H85541/64	3/4	19.05	92.50	166.5	50.0	DIN6535HB
H85517.0	–	20.00	97.50	171.5	50.0	DIN6535HE
H85511/16	3/4	19.05	97.50	171.5	50.0	DIN6535HB
H85518.0	–	20.00	103.50	176.5	50.0	DIN6535HE
H85523/32	3/4	19.05	103.50	176.5	50.0	DIN6535HB
H85519.0	–	25.00	108.50	191.5	56.0	DIN6535HE
H85549/64	1"	25.40	108.50	191.5	56.0	DIN6535HB
H85520.0	–	25.00	114.50	196.5	56.0	DIN6535HE
H85551/64	1"	25.40	114.50	196.5	56.0	DIN6535HB
H85521.0	–	25.00	119.50	196.5	56.0	DIN6535HE
H85527/32	1"	25.40	119.50	196.5	56.0	DIN6535HB
H85522.0	–	25.00	125.10	201.1	56.0	DIN6535HE
H85557/64	1"	25.40	125.10	201.1	56.0	DIN6535HB
H85523.0	–	25.00	129.50	210.5	56.0	DIN6535HE
H85559/64	1"	25.40	129.50	210.5	56.0	DIN6535HB
H85524.0	–	32.00	135.20	220.2	60.0	DIN6535HE
H85531/32	1"	25.40	135.20	220.2	60.0	DIN6535HB
H85525.0	–	32.00	140.00	225.0	60.0	DIN6535HE
H8551.1/64	1.1/4	31.75	140.00	225.0	60.0	DIN6535HB
H85526.0	–	32.00	146.00	230.0	60.0	DIN6535HE
H8551.3/64	1.1/4	31.75	146.00	230.0	60.0	DIN6535HB
H85527.0	–	32.00	151.00	235.0	60.0	DIN6535HE
H8551.3/32	1.1/4	31.75	151.00	235.0	60.0	DIN6535HB



Produit	DCONMS	DCON MS	LU	OAL	LS	ADINTMS
	(inch)	(mm)	(mm)	(mm)	(mm)	
H85528.0	–	32.00	157.00	240.0	60.0	DIN6535HE
H8551.1/8	1.1/4	31.75	157.00	240.0	60.0	DIN6535HB
H85529.0	–	32.00	162.00	245.0	60.0	DIN6535HE
H8551.11/64	1.1/4	31.75	162.00	245.0	60.0	DIN6535HB
H85530.0	–	32.00	167.00	255.0	60.0	DIN6535HE
H8551.3/16	1.1/4	31.75	167.00	255.0	60.0	DIN6535HB
H85532.0	–	32.00	176.50	261.5	60.0	DIN6535HE
H85533.5	–	32.00	186.50	271.5	60.0	DIN6535HE
H85535.0	–	40.00	196.50	291.5	70.0	DIN6535HB
H85536.5	–	40.00	201.50	296.5	70.0	DIN6535HB
H85538.0	–	40.00	211.50	306.5	70.0	DIN6535HB
H85539.5	–	40.00	221.50	316.5	70.0	DIN6535HB
H85541.0	–	40.00	226.50	325.6	70.0	DIN6535HB
H85542.5	–	40.00	236.50	336.5	70.0	DIN6535HB



H858



Corps HYDRA 8XD, avec arrosage centralisé, nickelage brillant

Corps utilisable avec les têtes R950, R960 et R970 HYDRA. Une gamme de diamètres de tête peut être utilisée avec le même corps. Les trous d'arrosage centralisé alignés avec les têtes offrent un refroidissement efficace. La surface nickelée brillante protège de la corrosion et améliore l'évacuation des copeaux.

HYDRA

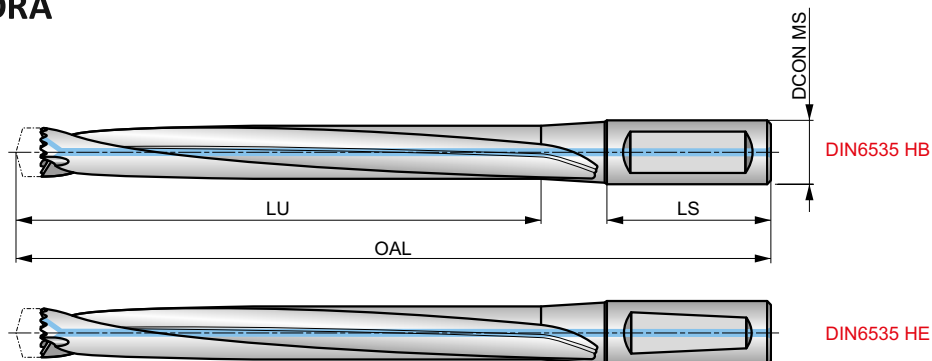

HSS	DORMER	8xD
Bright Ni	DIN 6535HB DIN 6535HE	R

Quatre (4) vis et un (1) tournevis sont livrés avec le corps du foret, DCON MS tolérance h6.

Produit	DCON MS	LU	OAL	LS	ADINTMS
	(mm)	(mm)	(mm)	(mm)	
H85814.0	16.00	124.50	191.5	48.0	DIN6535HE
H85815.0	20.00	133.50	201.5	50.0	DIN6535HE
H85816.0	20.00	141.50	211.5	50.0	DIN6535HE
H85817.0	20.00	150.50	221.5	50.0	DIN6535HE
H85818.0	20.00	158.50	226.5	50.0	DIN6535HE
H85819.0	25.00	167.50	251.5	56.0	DIN6535HE
H85820.0	25.00	175.50	264.5	56.0	DIN6535HE
H85821.0	25.00	184.50	266.5	56.0	DIN6535HE
H85822.0	25.00	192.10	271.1	56.0	DIN6535HE
H85823.0	25.00	200.50	280.5	56.0	DIN6535HE
H85824.0	32.00	208.20	295.2	60.0	DIN6535HE
H85825.0	32.00	217.00	300.0	60.0	DIN6535HE
H85826.0	32.00	225.00	310.0	60.0	DIN6535HE
H85827.0	32.00	234.00	320.0	60.0	DIN6535HE
H85828.0	32.00	242.00	325.0	60.0	DIN6535HE
H85829.0	32.00	251.00	335.0	60.0	DIN6535HE
H85830.0	32.00	259.00	345.0	60.0	DIN6535HE
H85832.0	32.00	271.50	356.5	60.0	DIN6535HE
H85833.5	32.00	286.50	371.5	60.0	DIN6535HE
H85835.0	40.00	301.50	396.5	70.0	DIN6535HB
H85836.5	40.00	311.50	406.5	70.0	DIN6535HB
H85838.0	40.00	326.50	421.5	70.0	DIN6535HB
H85839.5	40.00	336.50	431.5	70.0	DIN6535HB
H85841.0	40.00	351.50	451.5	70.0	DIN6535HB
H85842.5	40.00	361.50	461.5	70.0	DIN6535HB

**NEW****H8512****DORMER****Corps HYDRA 12XD, avec arrosage centralisé, nickelage brillant**

Corps utilisable avec les têtes R950, R960 et R970 HYDRA. Une gamme de diamètres de tête peut être utilisée avec le même corps. Les trous d'arrosage centralisé alignés avec les têtes offrent un refroidissement efficace. La queue épaulée empêche le foret de se déplacer dans l'attachement. La surface nickelée protège de la corrosion et améliore l'évacuation des copeaux.

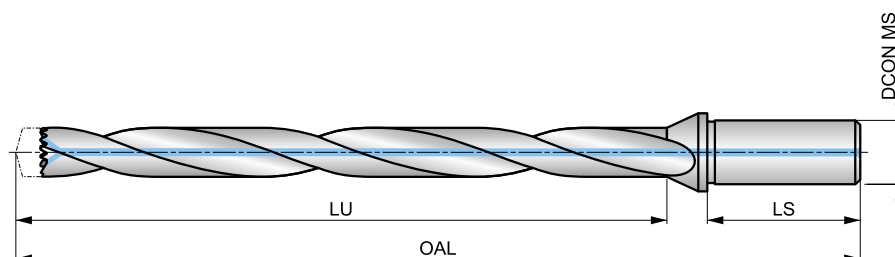
HYDRA

HSS	DORMER	12xD
Bright Ni		R

Quatre (4) vis et un (1) tournevis sont livrés avec le corps du foret, DCON MS tolérance h6.

Produit	DCON MS	LU	OAL	LS
	(mm)	(mm)	(mm)	(mm)
H851214.0	16.00	168.00	236.0	48.0
H851215.0	20.00	180.00	250.3	50.0
H851216.0	20.00	192.00	262.6	50.0
H851217.0	20.00	204.00	275.0	50.0
H851218.0	20.00	216.00	287.2	50.0
H851219.0	25.00	228.00	305.6	56.0
H851220.0	25.00	240.00	317.8	56.0
H851221.0	25.00	252.00	330.1	56.0
H851222.0	25.00	264.00	343.0	56.0
H851223.0	25.00	276.00	354.8	56.0
H851224.0	32.00	288.00	371.7	60.0
H851225.0	32.00	300.00	383.8	60.0



H860



Vis HYDRA

Vis de remplacement utilisées pour maintenir solidement les têtes HYDRA en place.

HYDRA

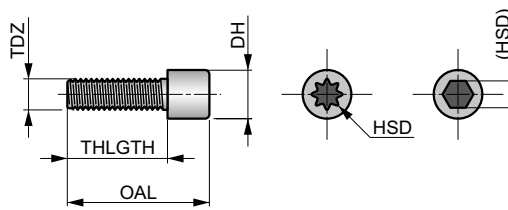

Produit	Nr.	TDZ	OAL	THLGTH	DH	HSD
			(mm)	(mm)	(mm)	
H860N1	1	M2.2	7.5	5.70	3.5	8IP
H860N2	2	M2.5	9.0	7.00	4.1	10IP
H860N3	3	M3.0	10.5	8.00	4.9	15IP
H860N4	4	M3.5	11.5	8.80	5.5	15IP
H860N5	5	M4.0	12.5	9.50	6.0	20IP
H860N6	6	M4.5	14.3	10.80	6.8	25IP
H860N7	7	M5.0	20.0	15.00	8.5	4



H861

DORMER



Tournevis HYDRA

Tournevis utilisés pour serrer les vis HYDRA.

HYDRA

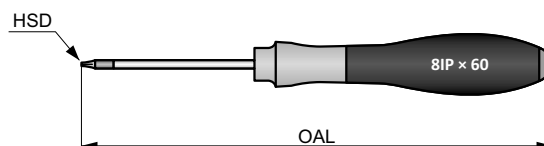

Produit	Nr.	HSD	OAL
			(mm)
H861N1	N1	8IP	164.0
H861N2	N2	10IP	191.0
H861N3	N3	15IP	191.0
H861N4	N4	20IP	218.0
H861N5	N5	25IP	218.0
H861N6	N6	4	186.0



FACTEURS DE CORRECTION DES CONDITIONS DE COUPE (SELON LONGUEUR CORPS HYDRA)

H851	Appliquer les valeurs de vitesse et d'avance initiales avec un facteur de correction de 1.10
H853	Appliquer les valeurs de vitesse et d'avance initiales avec un facteur de correction de 1.00
H855	Appliquer les valeurs de vitesse et d'avance initiales avec un facteur de correction de 0.95
H858	Appliquer les valeurs de vitesse et d'avance initiales avec un facteur de correction de 0.90
H8512	Appliquer les valeurs de vitesse et d'avance initiales avec un facteur de correction de 0.80



**FORETS INDEXABLES
INFORMATIONS TECHNIQUES**



HYDRA – INFORMATIONS TECHNIQUES

Tableau des couples de serrage des vis

H860	H861	Tête Hydra ø Plage (mm)	Tête Hydra ø Plage (fractions)	Tête Hydra ø Plage décimale (min. / max.)	Valeurs de couple Nm	Valeurs de couple po/livres
H860N1	H861N1	12.0 mm – 15.5 mm	15/32" – 39/64"	0.4688" – 0.6102"	0.75 – 0.99	6.6 – 8.8
H860N2	H861N2	15.6 mm – 18.5 mm	5/8" – 23/32"	0.6142" – 0.7283v	0.93 – 1.24	8.2 – 11.0
H860N3	H861N3	18.6 mm – 21.5 mm	47/64" – 27/32"	0.7323" – 0.8465"	1.84 – 2.44	16.3 – 21.6
H860N4	H861N3	22.0 mm – 24.5 mm	55/64" – 31/32"	0.8594" – 0.9688"	2.73 – 3.72	24.2 – 32.9
H860N5	H861N4	25.0 mm – 27.5 mm	63/64" – 1-3/32"	0.9843" – 1.0938"	4.14 – 5.52	36.6 – 48.8
H860N6	H861N5	28.0 mm – 33.5 mm	1-7/64" – 1-19/64"	1.1024" – 1.3189"	4.97 – 6.63	44.0 – 58.7
H860N7	H861N6	34.0 mm – 42.0 mm	1-11/32" – 1-5/8"	1.3386" – 1.6535"	7.2	63.7

Données vis et tournis

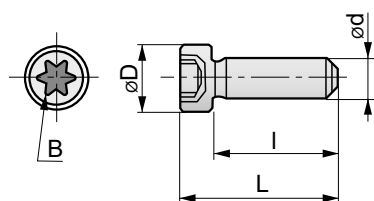

modèle	d	Pas	L (mm)	I (mm)	D (mm)	B
H860N1	M2.2	0.45	7.5	5.7	3.5	8IP
H860N2	M2.5	0.45	9.0	7.0	4.1	10IP
H860N3	M3.0	0.50	10.5	8.0	4.9	15IP
H860N4	M3.5	0.60	11.5	8.8	5.5	15IP
H860N5	M4.0	0.70	12.5	9.5	6.0	20IP
H860N6	M4.5	0.75	14.3	10.8	6.8	25IP

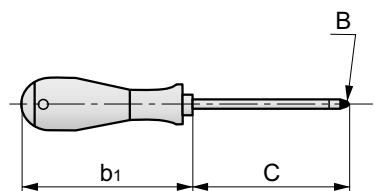

modèle	B	C	b ₁
H861N1	8IP	60	104
H861N2	10IP	80	111
H861N3	15IP	80	111
H861N4	20IP	100	118
H861N5	25IP	100	118

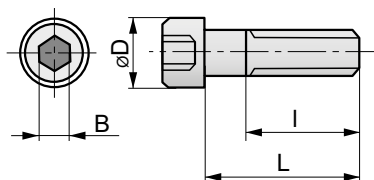

modèle	d	Pas	L (mm)	I (mm)	D (mm)	B
H860N7	M5.0	0.8	15	full	8.5	4

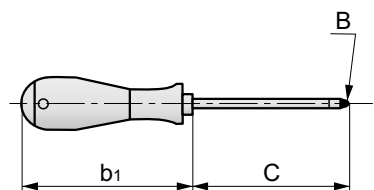

modèle	B	C	b ₁
H861N6	4	75	111



HYDRA – INFORMATIONS TECHNIQUES

Suivre une programmation spéciale pour les perçages 8×D et 12×D

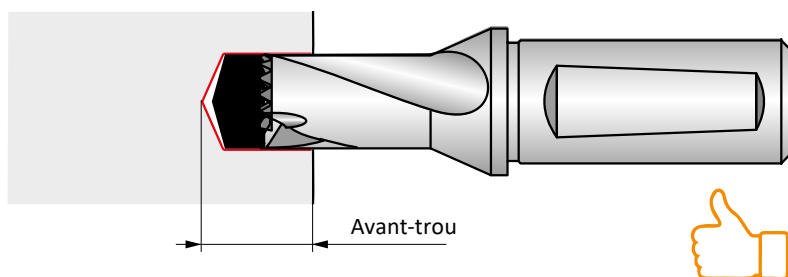

Perçer un avant-trou (1.5×D à 3×D de profondeur) avec une tête HYDRA de même diamètre (au besoin, vérifier l'excentricité: max. + 0,05 mm).

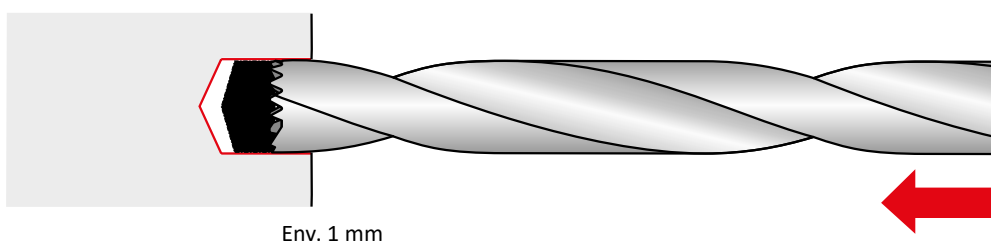

Rentrer le corps 8×D ou 12×D dans l'avant-trou à une vitesse de 500 tr/min maximum, jusqu'à environ 1 mm du fond de l'avant-trou.

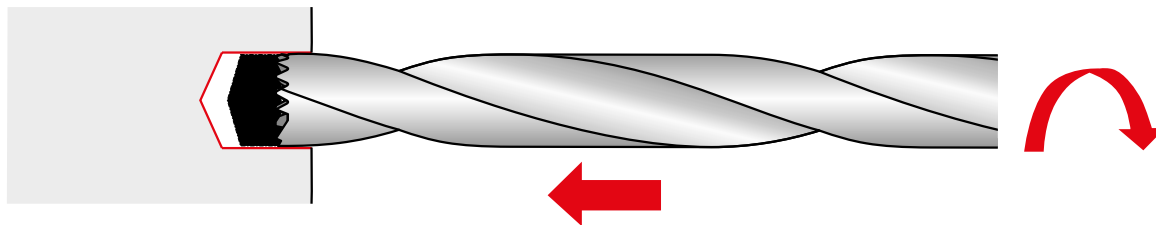

Activer le flux de fluide de coupe et augmenter la rotation jusqu'à la vitesse recommandée.

Remarque : limiter la durée de présence dans le trou et ne pas entamer l'avance avant que la rotation recommandée ait été atteinte.

Perçer jusqu'à la profondeur voulue sans déburrage.

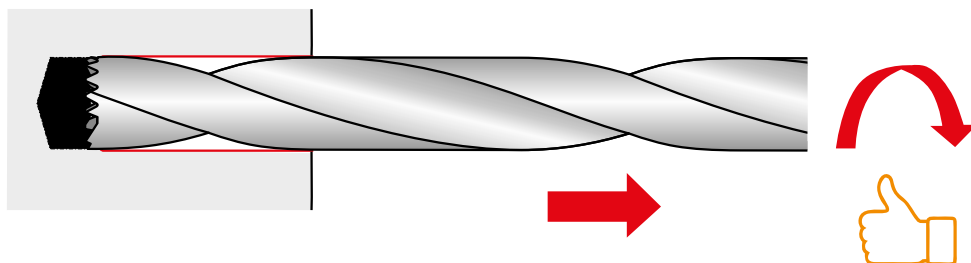

Une fois la profondeur atteinte, retirer le foret d'environ 0,1 mm à 0,5 mm et réduire la vitesse à 500 tr/min, puis retirer complètement le foret à vitesse d'avance normale. **Remarque : le fait de sortir le foret à une vitesse de broche plus élevée pourrait endommager l'épaulement ou la surface du trou et altérer la tolérance.**



Conseils de perçage avec un foret hydra

Fluides de coupe

Pour une évacuation des copeaux et une performance de l'outil optimales, il est recommandé d'utiliser un fluide de coupe. Une concentration d'émulsion de fluide de coupe de 6 à 8 % est recommandée dans la plupart des applications, à une pression de 20 bar (290 PSI) ou plus. Pour l'acier à haute résistance, les aciers inoxydables et les matériaux tenaces, utiliser une concentration de 10 à 12 %. Dans ces applications, notamment avec les aciers inoxydables, il est recommandé d'utiliser la pression maximale de fluide de coupe sur la machine. Les trous d'arrosage des forets Hydra améliorent la résistance de l'âme et réduisent la chaleur au niveau des arêtes de coupe, ce qui augmente la productivité et la durée de vie de l'outil.

Porte-outils

Toujours utiliser des porte-outils et pinces de serrage pour assurer

une bonne concentricité entre le foret et la broche de la machine. Utiliser une butée pour empêcher l'outil de reculer dans le porte-outil. Le saut radial de l'outil dans le porte-outil doit être vérifié et maintenu avec précision.

Pièce usinée

La pièce à usiner doit être stable et correctement fixée pour limiter toute déviation, et améliorer la précision et le positionnement du trou.

Avances

Il est important d'assurer une avance suffisante du foret pour éviter qu'il ne stagne et ne s'émousse. Ceci est d'autant plus vrai dans les matériaux de trempe. Les avances doivent être suffisantes pour permettre une bonne formation de copeaux.

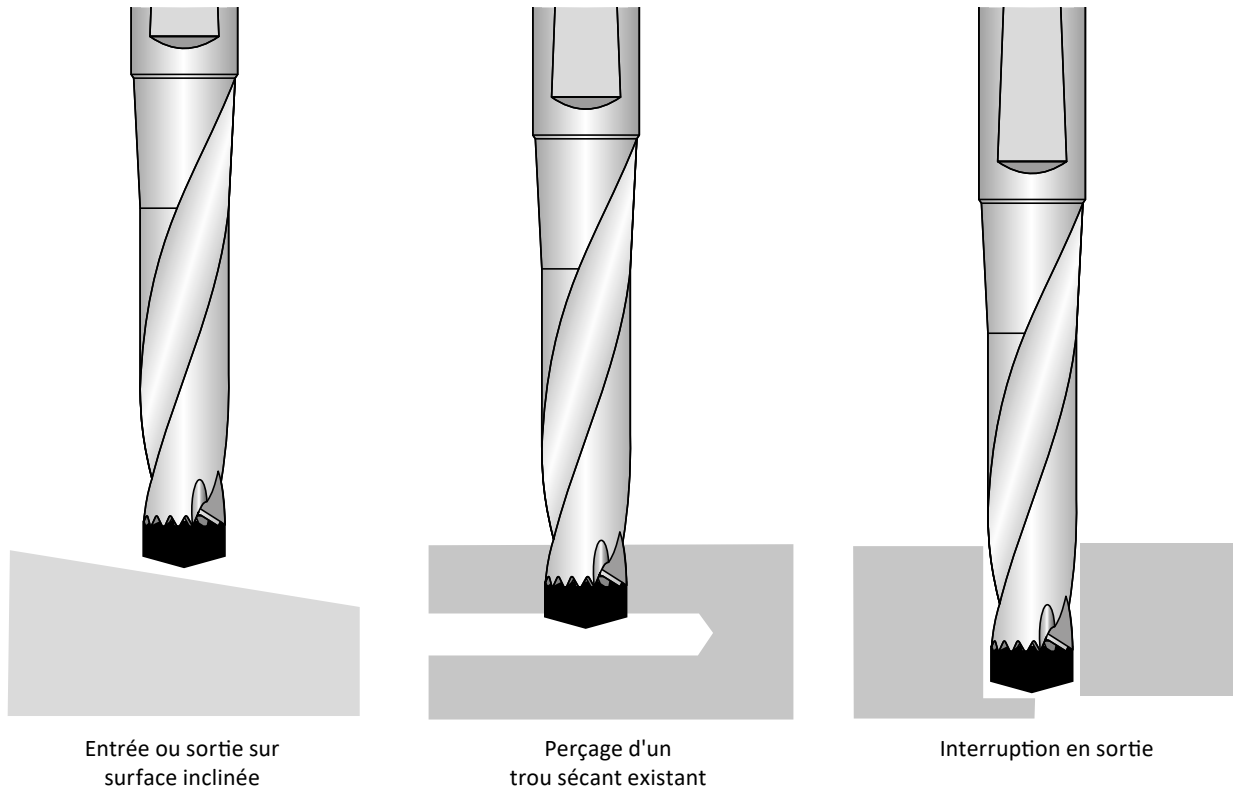

Dans ces situations, il est généralement recommandé de réduire l'avance de 1/3 (33 %). Le perçage avec un angle d'entrée de plus de 10° n'est PAS recommandé. Il est conseillé d'usiner la surface pour qu'elle soit plane avant de percer.



INFORMATIONS TECHNIQUES GÉNÉRALES

	Nuance	Dureté (HV10)	C %	W %	Mo %	Cr %	V %	Co %	Matériau de l'outil
HSS	M2	810 – 850	0.9	6.4	5.0	4.2	1.8	–	HSS

Propriétés	Aciers rapides (HSS)	Carbures	K10/30F (pour outils monoblocs généralement)
Dureté (HV30)	800 – 950	1300 – 1800	1600
Densité (g/cm³)	8.0 – 9.0	7.2 – 15	14.45
Résistance à la compression (N/mm²)	3000 – 4000	3000 – 8000	6250
Résistance à la flexion (N/mm²)	2500 – 4000	1000 – 4700	4300
Résistance thermique (°C)	550	1000	900
Module de cisaillement (KN/mm²)	260 – 300	460 – 630	580
Taille de grain (µm)	–	0.2 – 10	0.8

La combinaison de particules dures (WC) et d'un métal liant (Co) fait évoluer les caractéristiques comme suit :

Caractéristique	Teneur supérieure en WC	Teneur supérieure en Co
Dureté	Dureté supérieure	Dureté inférieure
Résistance à la compression (CS)	CS supérieure	CS inférieure
Résistance à la flexion (BS)	BS inférieure	BS supérieure

La taille de grain a également une influence sur les propriétés du matériau. Plus la taille est réduite, plus la dureté augmente ; la ténacité augmente avec la taille du grain.



INFORMATIONS TECHNIQUES GÉNÉRALES

Tolérances standard pour les arbres et trous

Valeurs de tolérance exprimées en microns (μm)

Formule ...1 μm = 0,001 mm / 0,000039" pouce

Tolérance	Diamètre (mm)							
	> 1 ≤ 3	> 3 ≤ 6	> 6 ≤ 10	> 10 ≤ 18	> 18 ≤ 30	> 30 ≤ 50	> 50 ≤ 80	> 80 ≤ 120
	Diamètre (pouces)							
	> 0.039" ≤ 0.118"	> 0.118" ≤ 0.236"	> 0.236" ≤ 0.394"	> 0.394" ≤ 0.709"	> 0.709" ≤ 1.181"	> 1.181" ≤ 1.968"	> 1.968" ≤ 3.149"	> 3.149" ≤ 4.724"
Valeurs de tolérance (μm)								
e8	-14 / -28	-20 / -38	-25 / -47	-32 / -59	-40 / -73	-50 / -89	-60 / -106	-72 / -126
f6	-6 / -12	-10 / -18	-13 / -22	-16 / -27	-20 / -33	-25 / -41	-30 / -49	-36 / -58
f7	-6 / -16	-10 / -22	-13 / -28	-16 / -34	-20 / -41	-25 / -50	-30 / -60	-36 / -71
h6	0 / -6	0 / -8	0 / -9	0 / -11	0 / -13	0 / -16	0 / -19	0 / -22
h7	0 / -10	0 / -12	0 / -15	0 / -18	0 / -21	0 / -25	0 / -30	0 / -35
h8	0 / -14	0 / -18	0 / -22	0 / -27	0 / -33	0 / -39	0 / -46	0 / -54
h9	0 / -25	0 / -30	0 / -36	0 / -43	0 / -52	0 / -62	0 / -74	0 / -87
h10	0 / -40	0 / -48	0 / -58	0 / -70	0 / -84	0 / -100	0 / -120	0 / -140
h11	0 / -60	0 / -75	0 / -90	0 / -110	0 / -130	0 / -160	0 / -190	0 / -220
h12	0 / -100	0 / -120	0 / -150	0 / -180	0 / -210	0 / -250	0 / -300	0 / -350
k10	+ 40 / 0	+ 48 / 0	+ 58 / 0	+ 70 / 0	+ 84 / 0	+ 100 / 0	+ 120 / 0	+ 140 / 0
k12	+ 100 / 0	+ 120 / 0	+ 150 / 0	+ 180 / 0	+ 210 / 0	+ 250 / 0	+ 300 / 0	+ 350 / 0
m7	+ 2 / + 12	+ 4 / + 16	+ 6 / + 21	+ 7 / + 25	+ 8 / + 29	+ 9 / + 34	+ 11 / + 41	+ 13 / + 48
js14	+ / -125	+ / -150	+ / -180	+ / -215	+ / -260	+ / -310	+ / -370	+ / -435
js16	+ / -300	+ / -375	+ / -450	+ / -550	+ / -650	+ / -800	+ / -950	+ / -1100
H7	+ 10 / 0	+ 12 / 0	+ 15 / 0	+ 18 / 0	+ 21 / 0	+ 25 / 0	+ 30 / 0	+ 35 / 0
H8	+ 14 / 0	+ 18 / 0	+ 22 / 0	+ 27 / 0	+ 33 / 0	+ 39 / 0	+ 46 / 0	+ 54 / 0
H9	+ 25 / 0	+ 30 / 0	+ 36 / 0	+ 43 / 0	+ 52 / 0	+ 62 / 0	+ 74 / 0	+ 87 / 0
H12	+ 100 / 0	+ 120 / 0	+ 150 / 0	+ 180 / 0	+ 210 / 0	+ 250 / 0	+ 300 / 0	+ 350 / 0
P9	-6 / -31	-12 / -42	-15 / -51	-18 / -61	-22 / -74	-26 / -86	-32 / -106	-37 / -124
S7	-13 / -22	-15 / -27	-17 / -32	-21 / -39	-27 / -48	-34 / -59	-42 / -72	-58 / -93



INFORMATIONS TECHNIQUES GÉNÉRALES

Tableau des vitesses de coupe

		Vc															
m/min.		5	8	10	15	20	25	30	40	50	60	70	80	90	100	110	150
SFM (pieds/min.)		16	26	32	50	66	82	98	130	165	197	230	262	296	330	362	495
Ø		Tr/min															
mm	po																
1.00	—	1592	2546	3183	4775	6366	7958	9549	12732	15916	19099	22282	25465	28648	31831	35014	47747
1.50	—	1061	1698	2122	3183	4244	5305	6366	8488	10610	12732	14854	16977	19099	21221	23343	31831
2.00	—	796	1273	1592	2387	3183	3979	4775	6366	7958	9549	11141	12732	14324	15916	17507	23873
2.50	—	637	1019	1273	1910	2546	3183	3820	5093	6366	7639	8913	10186	11459	12732	14006	19099
3.00	—	531	849	1061	1592	2122	2653	3183	4244	5305	6366	7427	8488	9549	10610	11671	15916
3.18	1/8	500	801	1001	1501	2002	2502	3003	4004	5005	6006	7007	8008	9009	10010	11011	15015
3.50	—	455	728	909	1364	1819	2274	2728	3638	4547	5457	6366	7276	8185	9095	10004	13642
4.00	—	398	637	796	1194	1592	1989	2387	3183	3979	4775	5570	6366	7162	7958	8754	11937
4.50	—	354	566	707	1061	1415	1768	2122	2829	3537	4244	4951	5659	6366	7074	7781	10610
4.76	3/16	334	535	669	1003	1337	1672	2006	2675	3344	4012	4681	5350	6018	6687	7356	10031
5.00	—	318	509	637	955	1273	1592	1910	2546	3183	3820	4456	5093	5730	6366	7003	9549
6.00	—	265	424	531	796	1061	1326	1592	2122	2653	3183	3714	4244	4775	5305	5836	7958
6.35	1/4	251	401	501	752	1003	1253	1504	2005	2506	3008	3509	4010	4511	5013	5514	7519
7.00	—	227	364	455	682	909	1137	1364	1819	2274	2728	3183	3638	4093	4547	5002	6821
7.94	5/16	200	321	401	601	802	1002	1203	1604	2004	2405	2806	3207	3608	4009	4410	6013
8.00	—	199	318	398	597	796	995	1194	1592	1989	2387	2785	3183	3581	3979	4377	5968
9.00	—	177	283	354	531	707	884	1061	1415	1768	2122	2476	2829	3183	3537	3890	5305
9.53	3/8	167	267	334	501	668	835	1002	1336	1670	2004	2338	2672	3006	3340	3674	5010
10.00	—	159	255	318	477	637	796	955	1273	1592	1910	2228	2546	2865	3183	3501	4775
11.11	7/16	143	229	287	430	573	716	860	1146	1433	1719	2006	2292	2579	2865	3152	4298
12.00	—	133	212	265	398	531	663	796	1061	1326	1592	1857	2122	2387	2653	2918	3979
12.70	1/2	125	201	251	376	501	627	752	1003	1253	1504	1754	2005	2256	2506	2757	3760
14.00	—	114	182	227	341	455	568	682	909	1137	1364	1592	1819	2046	2274	2501	3410
14.29	9/16	111	178	223	334	446	557	668	891	1114	1337	1559	1782	2005	2228	2450	3341
15.00	—	106	170	212	318	424	531	637	849	1061	1273	1485	1698	1910	2122	2334	3183
15.88	5/8	100	160	200	301	401	501	601	802	1002	1203	1403	1604	1804	2004	2205	3007
16.00	—	99	159	199	298	398	497	597	796	995	1194	1393	1592	1790	1989	2188	2984
17.46	11/16	91	146	182	273	365	456	547	729	912	1094	1276	1458	1641	1823	2005	2735
18.00	—	88	141	177	265	354	442	531	707	884	1061	1238	1415	1592	1768	1945	2653
19.05	3/4	84	134	167	251	334	418	501	668	835	1003	1170	1337	1504	1671	1838	2506
20.00	—	80	127	159	239	318	398	477	637	796	955	1114	1273	1432	1592	1751	2387
24.00	—	66	106	133	199	265	332	398	531	663	796	928	1061	1194	1326	1459	1989
25.00	—	64	102	127	191	255	318	382	509	637	764	891	1019	1146	1273	1401	1910
27.00	—	59	94	118	177	236	295	354	472	589	707	825	943	1061	1179	1297	1768
30.00	—	53	85	106	159	212	265	318	424	531	637	743	849	955	1061	1167	1592
32.00	—	50	80	99	149	199	249	298	398	497	597	696	796	895	995	1094	1492
36.00	—	44	71	88	133	177	221	265	354	442	531	619	707	796	884	973	1326
40.00	—	40	64	80	119	159	199	239	318	398	477	557	637	716	796	875	1194
50.00	—	32	51	64	95	127	159	191	255	318	382	446	509	573	637	700	955



INFORMATIONS TECHNIQUES GÉNÉRALES

Dureté et résistance à la traction

HV	HRC	HB	Résistance	
			N/mm ²	Tonnes/po ²
Vickers	Rockwell	Brinell		
940	68	—	—	—
900	67	—	—	—
864	66	—	—	—
829	65	—	—	—
800	64	—	—	—
773	63	—	—	—
745	62	—	—	—
720	61	—	—	—
698	60	—	—	—
675	59	—	—	—
655	58	—	2200	142
650	—	618	2180	141
640	—	608	2145	139
639	57	607	2140	138
630	—	599	2105	136
620	—	589	2070	134
615	56	584	2050	133
610	—	580	2030	131
600	—	570	1995	129
596	55	567	1980	128
590	—	561	1955	126
580	—	551	1920	124
578	54	549	1910	124
570	—	542	1880	122
560	53	532	1845	119
550	—	523	1810	117
544	52	517	1790	116
540	—	513	1775	115
530	—	504	1740	113
527	51	501	1730	112
520	—	494	1700	110
514	50	488	1680	109
510	—	485	1665	108
500	—	475	1630	105
497	49	472	1620	105
490	—	466	1595	103
484	48	460	1570	102
480	—	456	1555	101
473	47	449	1530	99
470	—	447	1520	98
460	—	437	1485	96
458	46	435	1480	96
450	—	428	1455	94
446	45	424	1440	93
440	—	418	1420	92

HV	HRC	HB	Résistance	
			N/mm ²	Tonnes/po ²
Vickers	Rockwell	Brinell		
434	44	413	1400	91
423	43	402	1360	88
413	42	393	1330	86
403	41	383	1300	84
392	40	372	1260	82
382	39	363	1230	80
373	38	354	1200	78
364	37	346	1170	76
355	36	337	1140	74
350	—	333	1125	73
345	35	328	1110	72
340	—	323	1095	71
336	34	319	1080	70
330	—	314	1060	69
327	33	311	1050	68
320	—	304	1030	67
317	32	301	1020	66
310	31	295	995	64
302	30	287	970	63
300	—	285	965	62
295	—	280	950	61
293	29	278	940	61
290	—	276	930	60
287	28	273	920	60
285	—	271	915	59
280	27	266	900	58
275	—	261	880	57
272	26	258	870	56
270	—	257	865	56
268	25	255	860	56
265	—	252	850	55
260	24	247	835	54
255	23	242	820	53
250	22	238	800	52
245	—	233	785	51
243	21	231	780	50
240	—	228	770	50
235	—	223	755	49
230	—	219	740	48
225	—	214	720	47
220	—	209	705	46
215	—	204	690	45
210	—	199	675	44
205	—	195	660	43
200	—	190	640	41



DORMER PRAMET



RECHERCHE RAPIDE

Notre bibliothèque numérique vous permet de rechercher rapidement du texte dans les publications Dormer Pramet des dernières années. Téléchargez-la dès maintenant depuis votre magasin d'applis. **Simply Reliable.**

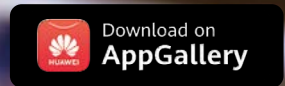



FORETS À PLAQUETTES



FORETS A PLAQUETTES

Longueur utile	2×D	3×D	4×D	5×D	XPET..AP	SCET..UD	XPET..AP-SD	SCET..-SD
Photo								
Arrosage					-	-	-	-
	313	315	318	320	324	323	324	323
Type de foret	802D	803D	804D	805D	-	-	-	-
Tolérance de foret	± 0.05	± 0.05	± 0.05	± 0.05	-	-	-	-
Tolérance de perçage *	0/+0.2	0/+0.3	0/+0.4	0/+0.5	-	-	-	-
Finition de surface *	R _a 2–6 μm	R _a 2–6 μm	R _a 2–6 μm	R _a 2–6 μm	-	-	-	-
Plage de diamètres	15.0–40.0	15.0–58.0	17.0–58.0	19.0–31.0	-	-	-	-
Domaines d'application	P1				■	■	■	■
	P2				■	■	■	■
	P3				■	■	■	■
	P4				■	■	■	■
	M1						■	■
	M2						■	■
	M3						■	■
	M4						■	■
	K1				▣	■	▣	▣
	K2				▣	■	▣	▣
	K3				▣	■	▣	▣
	K4				▣	■	▣	▣
	K5				▣	■	▣	▣
	S1						▣	▣
	S2						▣	▣
	S3						▣	▣
S4						▣	▣	

* La tolérance du perçage et de la finition de surface dépendent fortement des caractéristiques de la machine



FORETS À PLAQUETTES – RECHERCHE PAR NUANCES

Identification de la nuance	Domaine d'application	Application	Avance	Vitesse de coupe	Résistance en conditions de travail compliquées	Revêtement	Couleur	Substrat	Bénéfice arrosage	Description de la nuance
D9335	P20 - P35	■				MT-CVD		FGM	+++	Cette nuance est recommandée pour les plaquettes périphériques des forêts indexables ; elle convient parfaitement aux vitesses de coupe et aux avances les plus élevées.
	M15 - M30	■								
	K15 - K35	■								
	S10 - S20	■								
D8330	P20 - P35	■				PVD		submicron H	+++	Il s'agit d'une nuance universelle pour les plaquettes périphériques des forêts indexables ; elle peut être utilisée sur la plupart des matériaux et se distingue par sa grande fiabilité opérationnelle.
	M15 - M30	■								
	K15 - K35	■								
	S10 - S20	■								
D8345	P30 - P50	■				PVD		submicron H	+++	Cette nuance est une nuance universelle pour la plaquette centrale des forêts indexables ; elle est extrêmement résistante et convient à la plupart des matériaux.
	M20 - M40	■								
	K30 - K40	■								
	S20 - S30	■								

Substrat

submicron H	Substrat à grains fins base WC-Co (< 1 µm)
FGM	Substrat gradient fonctionnel

Revêtement

MT-CVD	Méthode de revêtement par dépôt chimique à moyenne température
PVD	Méthode de revêtement par dépôt physique à basse température

Bénéfices de l'arrosage

+++	L'utilisation de l'arrosage est essentielle
-----	---



PLAQUETTES – CODIFICATION ISO

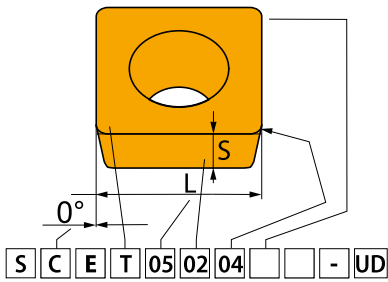

ISO	1	2	3	4
	S	C	E	T
ANSI	1	2	3	4
	S	C	E	T

1				2				4														
Forme de la plaquette				Angle de dépouille de la plaquette				Type de plaquette														
H	O	P	R	A	B	C	D	N	R	F	A	M	G	W	T	Q	U	B	H	C	J	X
S	T	C	D	E	F	G	N															
E	M	V	W																			
L	A	B	K	P	O		Spécial															

3 3 Tolérances

	(mm)			(")		
	M(±)	S(±)	IC(±)	M(±)	S(±)	IC(±)
A	0.005	0.025	0.025	.0002"	.001"	.0010"
F	0.005	0.025	0.013	.0002"	.001"	.0005"
C	0.013	0.025	0.025	.0005"	.001"	.0010"
H	0.013	0.025	0.013	.0005"	.001"	.0005"
E	0.025	0.025	0.025	.0010"	.001"	.0010"
G	0.025	0.130	0.025	.0010"	.005"	.0010"
J	0.005	0.025	0.05 – 0.13	.0002"	.001"	.002 – 0.005"
K	0.013	0.025	0.05 – 0.13	.0005"	.001"	.002 – 0.005"
L	0.025	0.025	0.05 – 0.13	.0010"	.001"	.002 – 0.005"
M	0.08 – 0.18	0.130	0.05 – 0.13	.003 – 0.007"	.005"	.002 – 0.005"
N	0.08 – 0.18	0.025	0.05 – 0.13	.003 – 0.007"	.001"	.002 – 0.005"
U	0.05 – 0.38	0.130	0.05 – 0.13	.005 – 0.015"	.005"	.003 – 0.010"

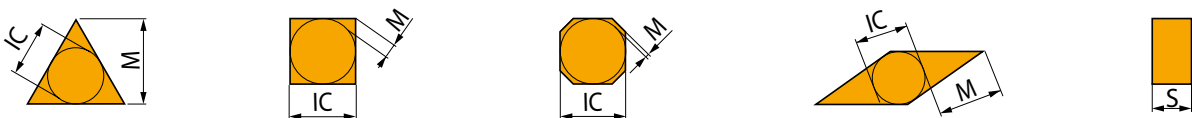



PLAQUETTES – CODIFICATION ISO

5	6	7	8	9	10
05	02	04			UD
5	6	7	8	9	10
1.8	1.5	1			UD

5		5											
Longueur de l'arête de coupe (taille de plaquette)													
d=IC	H	O	P	S	T	C	D	E	M	V	W	R	K
(mm)													
(in)													
3.97				03	06		04			06	02		
4.76				04	08	04	05	04	04	08	L3		
5.56				05	09	05	06	05	05	09	03		
6.35	03	02	04	08	11	06	07	08	08	11	04	06	
7.94	04	03	05	07	13	08	09	06	07	13	05	07	
9.525	05	04	07	09	16	09	11	09	09	16	06	09	16
12.7	07	05	09	12	22	12	15	13	12	22	08	12	
15.875	09	06	11	15	27	16	19	16	15	27	10	15	
19.05	11	07	13	19	33	19	23	19	19	33	13	19	
25.40	14	10	18	25	44	25	31	26	25	44	17	25	
31.75	18	13	23	31	54	32	38	32	31	54	21	31	

6	
Épaisseur de la plaquette	
	S
	(mm) (")
01	1.59 1/16"
T1	1.98 5/64"
02	2.38 3/32"
03	3.18 1/8"
T3	3.97 5.32"
04	4.76 3/16"
05	5.56 7/32"
06	6.35 1/4"
07	7.94 5/16"
09	9.52 3/8"

7	
Rayon de pointe de la plaquette	
	RE
	(mm) (")
00	0 0"
02	0.2 1/128"
04	0.4 1/64"
08	0.8 1/32"
12	1.2 3/64"
16	1.6 1/16"
24	2.4 3/32"
32	3.2 1/8"
Plaquettes rondes	
d=I.C.	
(")	00
(mm)	M0

ANSI			
5	6	7	
Cercle inscrit	Épaisseur de la plaquette	Rayon de pointe de la plaquette	
Symbol	Symbol	Symbol	
		RE	
	(mm) (")	(mm) (")	
1	1.588 1/16"	0	0 0"
1.2	1.984 5/64"	0.2	0.099 1/256"
1.5	2.381 3/32"	0.5	0.198 1/128"
1.8	3.175 1/8"	1	0.397 1/64"
2	3.969 5/32"	2	0.794 1/32"
2.5	4.763 3/16"	3	1.191 3/64"
3	5.556 7/32"	4	1.588 1/16"
4	6.350 1/4"	5	1.984 5/64"
5	7.938 5/16"	6	2.381 3/32"
6	9.525 3/8"	7	2.778 7/64"
7	11.113 7/16"	8	3.175 1/8"
8	12.700 1/2"	10	3.969 5/32"
10	14.288 9/16"	12	4.763 3/16"
12	15.875 5/8"	14	5.556 7/32"
		16	6.350 1/4"

8		8	
Configuration de l'arête de coupe			
	Arêtes vives		Arêtes arrondies
	Arêtes avec listel		Arêtes arrondies avec listel
	Arêtes avec double listel		Arêtes arrondies avec double listel

9		9	
Direction d'avance			
R		N	
L			
10		10	
Désignation du brise-copeaux (géométrie)			



CODIFICATION DES FORETS

1	2	3	-	4	-	5	-	6	7
8	05	D	-	19	-	95	-	S	25

*Le marquage est valable pour les forets produits depuis 2011



Forets à plaquettes indexables*

1		2		3		4	
Type d'outil		Longueur approximative		Version		Diamètre de coupe	
8	Foret à plaquettes indexables	02	2 × DC	D	Foret	15.5	DC = 15.5 mm
		03	3 × DC				19
		04	4 × DC				
		05	5 × DC				
5		6		7			
Profondeur de perçage max.		Type de queue		Diamètre de queue			
35	35 mm	E	Whistle Notch	25	DCON MS = 25 mm		
95	95 mm			32	DCON MS = 32 mm		
140	140 mm	S	ISO 9766	40	DCON MS = 40 mm		



802D

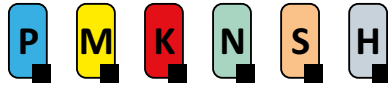

PRAMET

S



Corps de foret 802D 2xD à plaquettes indexables avec arrosage centralisé

Corps de foret à plaquettes indexables haute performance pour percer des trous borgnes et débouchants. Egalement pour perçage de trous sécants, décentrés et empilés, interpolation hélicoïdale, tréflage, perçage sur des surfaces concaves ou inclinées, perçage avec coupes interrompues, chanfreinage et alésage dans les paramètres de coupe recommandés. Disponible du Ø15 au Ø40 mm en 2xD.

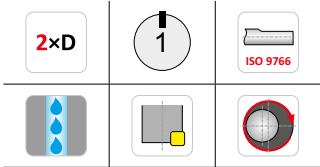
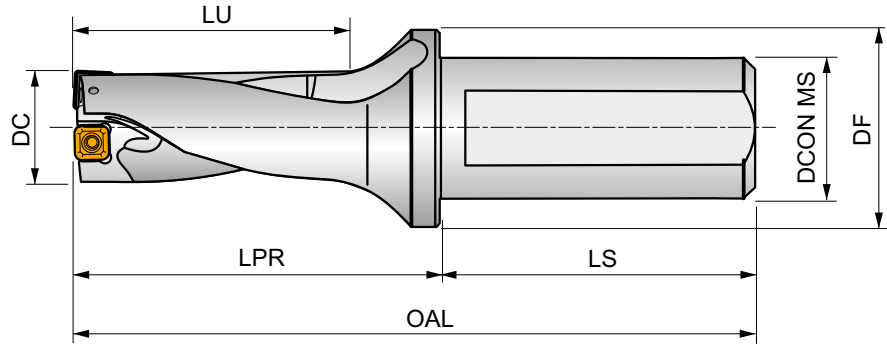

Produit	DC	APMX	OAL	LPR	LS	LU	DCON MS	DF	$\overset{-}{D}$	$\overset{+}{D}$	G1300	G1301	G1302	G1303	G1304	G1305	G1306	G1307	G1308	G1309	kg	HM001
	(mm)	(mm)	(mm)	(mm)	(mm)	(mm)		(mm)	(mm)	(mm)												
802D-15-30-S25	15	30.00	121	65	56	34.5	25	35	0.25	0.35	EP253253	GI300	GI313	0.30	HM001							
802D-16-32-S25	16	32.00	123	67	56	37	25	35	0.15	0.45	EP253253	GI300	GI313	0.30	HM001							
802D-17-34-S25	17	34.00	125	69	56	39.5	25	35	0.10	0.50	EP253253	GI300	GI313	0.31	HM001							
802D-18-36-S25	18	36.00	127	71	56	42	25	35	0.35	0.25	EP253253	GI301	GI314	0.31	HM002							
802D-19-38-S25	19	38.00	129	73	56	44.5	25	35	0.15	0.45	EP253253	GI301	GI314	0.32	HM002							
802D-20-40-S25	20	40.00	131	75	56	47	25	35	0.10	0.45	EP253253	GI302	GI315	0.33	HM003							
802D-21-42-S25	21	42.00	133	77	56	49.5	25	35	0.10	0.50	EP253253	GI302	GI315	0.34	HM003							
802D-22-44-S25	22	44.00	135	79	56	52	25	35	0.45	0.50	EP253253	GI303	GI316	0.35	HM004							
802D-23-46-S25	23	46.00	137	81	56	54.5	25	35	0.35	0.50	EP253253	GI304	GI317	0.36	HM005							
802D-24-48-S25	24	48.00	139	83	56	57	25	35	0.15	0.50	EP253253	GI304	GI317	0.37	HM005							
802D-25-50-S32	25	50.00	145	85	60	57	32	42	0.15	0.50	EP324058	GI304	GI317	0.57	HM005							
802D-26-52-S32	26	52.00	147	87	60	59.5	32	42	0.10	0.50	EP324058	GI304	GI317	0.58	HM005							
802D-27-54-S32	27	54.00	149	89	60	62	32	42	0.50	0.30	EP324058	GI305	GI318	0.59	HM006							
802D-28-56-S32	28	56.00	151	91	60	64.5	32	42	0.30	0.50	EP324058	GI306	GI319	0.61	HM007							
802D-29-58-S32	29	58.00	153	93	60	67	32	42	0.20	0.50	EP324058	GI306	GI319	0.62	HM007							
802D-30-60-S32	30	60.00	155	95	60	69.5	32	42	0.15	0.50	EP324058	GI306	GI319	0.67	HM007							
802D-32-64-S32	32	64.00	159	99	60	70	32	42	0.50	0.35	EP324058	GI307	GI320	0.68	HM008							
802D-32-64-S40	32	64.00	167	99	68	70	40	50	0.50	0.35	-	GI307	GI320	1.03	HM008							
802D-34-68-S32	34	68.00	163	103	60	75	32	42	0.25	0.50	EP324058	GI307	GI320	0.73	HM008							
802D-34-68-S40	34	68.00	171	103	68	75	40	50	0.25	0.50	-	GI307	GI320	1.07	HM008							
802D-36-72-S32	36	72.00	167	107	60	80	32	42	0.10	0.50	EP324058	GI308	GI321	0.76	HM009							
802D-36-72-S40	36	72.00	173	105	68	77.5	40	50	0.10	0.50	-	GI308	GI321	1.11	HM009							
802D-38-76-S32	38	76.00	171	111	60	85	32	42	0.50	0.50	EP324058	GI308	GI321	0.83	HM009							
802D-38-76-S40	38	76.00	179	111	68	85	40	50	0.50	0.50	-	GI308	GI321	1.17	HM009							
802D-40-80-S32	40	80.00	175	115	60	90	32	42	0.20	0.50	EP324058	GI309	GI322	0.91	HM009							
802D-40-80-S40	40	80.00	183	115	68	90	40	50	0.20	0.50	-	GI309	GI322	1.25	HM009							



GI300	XPET 0502AP	SCET 050204-UD
GI301	XPET 0602AP	SCET 050204-UD
GI302	XPET 0602AP	SCET 060204-UD
GI303	XPET 0703AP	SCET 060204-UD
GI304	XPET 0703AP	SCET 070308-UD
GI305	XPET 0903AP	SCET 070308-UD
GI306	XPET 0903AP	SCET 09T308-UD
GI307	XPET 11T3AP	SCET 09T308-UD
GI308	XPET 11T3AP	SCET 120408-UD
GI309	XPET 12T3AP	SCET 120408-UD
GI313	XPET 0502AP-SD	SCET 050204-SD
GI314	XPET 0602AP-SD	SCET 050204-SD
GI315	XPET 0602AP-SD	SCET 060204-SD
GI316	XPET 0703AP-SD	SCET 060204-SD
GI317	XPET 0703AP-SD	SCET 070308-SD
GI318	XPET 0903AP-SD	SCET 070308-SD
GI319	XPET 0903AP-SD	SCET 09T308-SD
GI320	XPET 11T3AP-SD	SCET 09T308-SD
GI321	XPET 11T3AP-SD	SCET 120408-SD
GI322	XPET 12T3AP-SD	SCET 120408-SD

HM001	US 2245-T07P	0.9	US 2245-T07P	0.9	FLAG T07P
HM002	US 2205-T07P	0.9	US 2245-T07P	0.9	FLAG T07P
HM003	US 2205-T07P	0.9	US 2205-T07P	0.9	FLAG T07P
HM004	US 2506-T07P	1.2	US 2506-T07P	1.2	FLAG T07P
HM005	US 2507-T08P	1.2	US 3007-T08P	2.0	FLAG T08P
HM006	US 3007-T09P	2.0	US 3007-T09P	2.0	FLAG T09P
HM007	US 3007-T09P	2.0	US 3009-T09P	2.0	FLAG T09P
HM008	US 3510-T15P	3.0	US 3508-T15P	3.0	FLAG T15P
HM009	US 3510-T15P	3.0	US 5012-T15P	5.0	FLAG T15P



803D

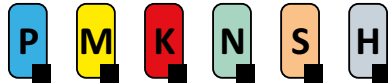

PRAMET

S



Corps de foret 803D 3xD à plaquettes indexables avec arrosage centralisé

Corps de foret à plaquettes indexables haute performance pour percer des trous borgnes et débouchants. Egalement pour perçage de trous sécants, décentrés et empilés, interpolation hélicoïdale, tréflage, perçage sur des surfaces concaves ou inclinées, perçage avec coupes interrompues, chanfreinage et alésage dans les paramètres de coupe recommandés. Disponible du Ø15 au Ø58 mm en 3xD.

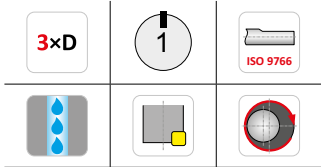
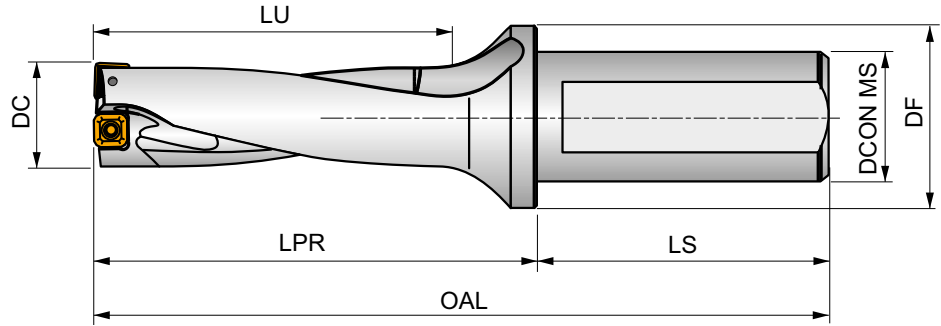

Produit	DC	APMX	OAL	LPR	LS	LU	DCON MS	DF	\bar{D}	\bar{D}^+	EP	GI	GI	kg	HM
	(mm)	(mm)	(mm)	(mm)	(mm)	(mm)	(mm)	(mm)	(mm)	(mm)					
803D-15-45-S25	15	45.00	136	80	56	49.5	25	35	0.25	0.35	EP253253	GI300	GI313	0.31	HM001
803D-15,5-46,5-S25	15.5	47.00	137.5	81.5	56	51.2	25	35	0.30	0.35	EP253253	GI300	GI313	0.31	HM001
803D-16-48-S25	16	48.00	139	83	56	53	25	35	0.15	0.45	EP253253	GI300	GI313	0.32	HM001
803D-16,5-49,5-S25	16.5	50.00	140.5	84.5	56	54.7	25	35	0.15	0.40	EP253253	GI300	GI313	0.32	HM001
803D-17-51-S25	17	51.00	142	86	56	56.5	25	35	0.10	0.50	EP253253	GI300	GI313	0.32	HM001
803D-17,5-52,5-S25	17.5	53.00	143.5	87.5	56	58.2	25	35	0.50	0.50	EP253253	GI301	GI314	0.32	HM002
803D-18-54-S25	18	54.00	145	89	56	60	25	35	0.35	0.25	EP253253	GI301	GI314	0.33	HM002
803D-18,5-55,5-S25	18.5	56.00	146.5	90.5	56	61.2	25	35	0.35	0.25	EP253253	GI301	GI314	0.34	HM002
803D-19-57-S25	19	57.00	148	92	56	63.5	25	35	0.15	0.45	EP253253	GI301	GI314	0.34	HM002
803D-19,5-58,5-S25	19.5	59.00	149.5	93.5	56	63.7	25	35	0.25	0.40	EP253253	GI302	GI315	0.34	HM003
803D-20-60-S25	20	60.00	151	95	56	67	25	35	0.10	0.45	EP253253	GI302	GI315	0.35	HM003
803D-20,5-61,5-S25	20.5	62.00	152.5	96.5	56	67.2	25	35	0.10	0.50	EP253253	GI302	GI315	0.36	HM003
803D-21-63-S25	21	63.00	154	98	56	70.5	25	35	0.10	0.50	EP253253	GI302	GI315	0.36	HM003
803D-21,5-64,5-S25	21.5	65.00	155.5	99.5	56	70.8	25	35	0.35	0.50	EP253253	GI303	GI316	0.37	HM004
803D-22-66-S25	22	66.00	157	101	56	74	25	35	0.45	0.50	EP253253	GI303	GI316	0.38	HM004
803D-22,5-67,5-S25	22.5	68.00	158.5	102.5	56	74.3	25	35	0.35	0.50	EP253253	GI304	GI317	0.39	HM005
803D-23-69-S25	23	69.00	160	104	56	77.5	25	35	0.35	0.50	EP253253	GI304	GI317	0.40	HM005
803D-23,5-70,5-S25	23.5	71.00	161.5	105.5	56	77.6	25	35	0.10	0.50	EP253253	GI304	GI317	0.40	HM005
803D-24-72-S25	24	72.00	163	107	56	81	25	35	0.15	0.50	EP253253	GI304	GI317	0.41	HM005
803D-24,5-73,5-S25	24.5	74.00	168.5	108.5	60	78.7	25	35	0.10	0.50	EP253253	GI304	GI317	0.42	HM005
803D-25-75-S32	25	75.00	170	110	60	82	32	42	0.15	0.50	EP324058	GI304	GI317	0.62	HM005
803D-25,5-76,5-S32	25.5	77.00	171.5	111.5	60	82.2	32	42	0.50	0.10	EP324058	GI304	GI317	0.63	HM005
803D-26-78-S32	26	78.00	173	113	60	85.5	32	42	0.10	0.50	EP324058	GI304	GI317	0.64	HM005
803D-26,5-79,5-S32	26.5	80.00	174.5	114.5	60	85.7	32	42	0.50	0.10	EP324058	GI305	GI318	0.65	HM006
803D-27-81-S32	27	81.00	176	116	60	89	32	42	0.50	0.30	EP324058	GI305	GI318	0.65	HM006
803D-28-84-S32	28	84.00	179	119	60	92.5	32	42	0.30	0.50	EP324058	GI306	GI319	0.68	HM007
803D-29-87-S32	29	87.00	182	122	60	96	32	42	0.20	0.50	EP324058	GI306	GI319	0.70	HM007



Produit	DC	APMX	OAL	LPR	LS	LU	DCONIMS	DF	$\overset{-}{D}$	$\overset{+}{D}$					
	(mm)	(mm)	(mm)	(mm)	(mm)	(mm)	(mm)	(mm)	(mm)	(mm)				kg	
803D-30-90-S32	30	90.00	185	125	60	99.5	32	42	0.15	0.50	EP324058	GI306	GI319	0.73	HM007
803D-31-93-S32	31	93.00	188	128	60	103	32	42	0.15	0.50	EP324058	GI306	GI319	0.76	HM007
803D-32-96-S32	32	96.00	191	131	60	102	32	42	0.50	0.30	EP324058	GI307	GI320	0.79	HM008
803D-32-96-S40	32	96.00	199	131	68	102	40	50	0.50	0.30	–	GI307	GI320	1.14	HM008
803D-33-99-S32	33	99.00	194	134	60	105.5	32	42	0.50	0.50	EP324058	GI307	GI320	0.83	HM008
803D-33-99-S40	33	99.00	202	134	68	105.5	40	50	0.50	0.50	–	GI307	GI320	1.18	HM008
803D-34-102-S32	34	102.00	197	137	60	109	32	42	0.25	0.50	EP324058	GI307	GI320	0.86	HM008
803D-34-102-S40	34	102.00	205	137	68	109	40	50	0.25	0.50	–	GI307	GI320	1.12	HM008
803D-35-105-S32	35	105.00	200	140	60	112.5	32	42	0.25	0.50	EP324058	GI308	GI321	0.90	HM009
803D-35-105-S40	35	105.00	208	140	68	112.5	40	50	0.25	0.50	–	GI308	GI321	1.24	HM009
803D-36-108-S32	36	108.00	203	143	60	116	32	42	0.10	0.50	EP324058	GI308	GI321	0.91	HM009
803D-36-108-S40	36	108.00	211	143	68	116	40	50	0.10	0.50	–	GI308	GI321	1.25	HM009
803D-37-111-S32	37	111.00	206	146	60	119.5	32	42	0.10	0.50	EP324058	GI308	GI321	0.95	HM009
803D-37-111-S40	37	111.00	214	146	68	119.5	40	50	0.10	0.50	–	GI308	GI321	1.29	HM009
803D-38-114-S32	38	114.00	199	139	60	124.5	32	42	0.50	0.50	EP324058	GI308	GI321	1.00	HM009
803D-38-114-S40	38	114.00	217	149	68	123	40	50	0.50	0.50	–	GI308	GI321	1.34	HM009
803D-39-117-S32	38	114.00	209	149	60	123	32	42	0.40	0.50	EP324058	GI309	GI322	1.06	HM009
803D-39-117-S40	39	117.00	220	152	68	126.5	40	50	0.40	0.50	–	GI309	GI322	1.40	HM009
803D-40-120-S32	40	120.00	215	155	60	130	32	42	0.20	0.50	EP324058	GI309	GI322	1.12	HM009
803D-40-120-S40	40	120.00	223	155	68	130	40	50	0.20	0.50	–	GI309	GI322	1.46	HM009
803D-41-123-S40	41	123.00	219	149	70	133	40	50	0.20	0.50	–	GI309	GI322	1.48	HM009
803D-42-126-S40	42	126.00	221.5	152	70	136	40	50	0.15	0.50	–	GI309	GI322	1.52	HM009
803D-43-129-S40	43	129.00	224	154	70	139	40	50	0.10	0.50	–	GI309	GI322	1.58	HM009
803D-44-132-S40	44	132.00	226.5	157	70	142	40	50	0.50	0.50	–	GI310	GI323	1.63	HM010
803D-45-135-S40	45	135.00	230.5	161	70	144	40	55	0.50	0.50	–	GI311	GI324	1.73	HM010
803D-46-138-S40	46	138.00	235	165	70	148	40	55	0.50	0.50	–	GI311	GI324	1.82	HM010
803D-47-141-S40	47	141.00	237.5	168	70	151	40	55	0.50	0.50	–	GI311	GI324	1.90	HM010
803D-48-144-S40	48	144.00	240	170	70	154	40	55	0.50	0.50	–	GI311	GI324	1.98	HM010
803D-49-147-S40	49	147.00	242.5	173	70	157	40	55	0.30	0.50	–	GI311	GI324	2.06	HM010
803D-50-150-S40	50	150.00	246.5	177	70	160	40	58	0.15	0.50	–	GI311	GI324	2.18	HM010
803D-51-153-S40	51	153.00	249	179	70	163	40	58	0.15	0.50	–	GI311	GI324	2.24	HM010
803D-52-156-S40	52	156.00	251.5	182	70	166	40	58	0.50	0.50	–	GI312	GI325	2.20	HM010
803D-53-159-S40	53	159.00	254	184	70	169	40	58	0.50	0.50	–	GI312	GI325	2.29	HM010
803D-54-162-S40	54	162.00	257.5	188	70	173	40	58	0.50	0.50	–	GI312	GI325	2.39	HM010
803D-55-165-S40	55	165.00	260	190	70	176	40	58	0.50	0.50	–	GI312	GI325	2.46	HM010
803D-56-168-S40	56	168.00	264	194	70	179	40	58	0.50	0.50	–	GI312	GI325	2.59	HM010
803D-57-171-S40	57	171.00	266.5	197	70	182	40	58	0.35	0.50	–	GI312	GI325	2.70	HM010
803D-58-174-S40	58	174.00	270	200	70	186	40	58	0.15	0.50	–	GI312	GI325	2.83	HM010

GI300	XPET 0502AP	SCET 050204-UD
GI301	XPET 0602AP	SCET 050204-UD
GI302	XPET 0602AP	SCET 060204-UD
GI303	XPET 0703AP	SCET 060204-UD
GI304	XPET 0703AP	SCET 070308-UD
GI305	XPET 0903AP	SCET 070308-UD
GI306	XPET 0903AP	SCET 09T308-UD
GI307	XPET 11T3AP	SCET 09T308-UD
GI308	XPET 11T3AP	SCET 120408-UD
GI309	XPET 12T3AP	SCET 120408-UD
GI310	XPET 1504AP	SCET 120408-UD
GI311	XPET 1504AP	SCET 150512-UD
GI312	XPET 1904AP	SCET 150512-UD
GI313	XPET 0502AP-SD	SCET 050204-SD
GI314	XPET 0602AP-SD	SCET 050204-SD
GI315	XPET 0602AP-SD	SCET 060204-SD
GI316	XPET 0703AP-SD	SCET 060204-SD
GI317	XPET 0703AP-SD	SCET 070308-SD
GI318	XPET 0903AP-SD	SCET 070308-SD
GI319	XPET 0903AP-SD	SCET 09T308-SD



GI320	XPET 11T3AP-SD	SCET 09T308-SD
GI321	XPET 11T3AP-SD	SCET 120408-SD
GI322	XPET 12T3AP-SD	SCET 120408-SD
GI323	XPET 1504AP-SD	SCET 120408-SD
GI324	XPET 1504AP-SD	SCET 150512-SD
GI325	XPET 1904AP-SD	SCET 150512-SD

HM001	US 2245-T07P	0.9	US 2245-T07P	0.9	FLAG T07P
HM002	US 2205-T07P	0.9	US 2245-T07P	0.9	FLAG T07P
HM003	US 2205-T07P	0.9	US 2205-T07P	0.9	FLAG T07P
HM004	US 2506-T07P	1.2	US 2506-T07P	1.2	FLAG T07P
HM005	US 2507-T08P	1.2	US 3007-T08P	2.0	FLAG T08P
HM006	US 3007-T09P	2.0	US 3007-T09P	2.0	FLAG T09P
HM007	US 3007-T09P	2.0	US 3009-T09P	2.0	FLAG T09P
HM008	US 3510-T15P	3.0	US 3508-T15P	3.0	FLAG T15P
HM009	US 3510-T15P	3.0	US 5012-T15P	5.0	FLAG T15P
HM010	US 4011-T15P	3.5	US 5012-T15P	5.0	FLAG T15P



804D

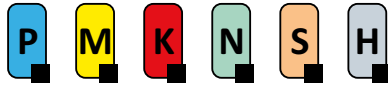

PRAMET

S



Corps de foret 804D 4xD à plaquettes indexables avec arrosage centralisé

Corps de foret à plaquettes indexables haute performance pour percer des trous borgnes et débouchants. Egalement pour perçage de trous sécants, décentrés et empilés, interpolation hélicoïdale, tréflage, perçage sur des surfaces concaves ou inclinées, perçage avec coupes interrompues, chanfreinage et alésage dans les paramètres de coupe recommandés. Disponible du Ø17 au Ø58 mm en 4xD.

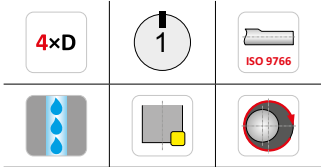
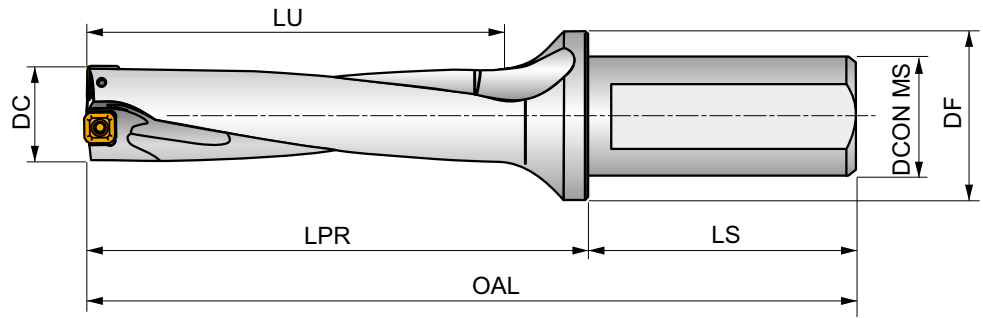

Produit	DC	APMX	OAL	LPR	LS	LU	DCON MS	DF	\bar{D}	D^+						
	(mm)	(mm)	(mm)	(mm)	(mm)	(mm)	(mm)	(mm)	(mm)							
804D-17-68-S25	17	68.00	149	93	56	73	25	35	0.10	0.50	–	GI300	GI313	0.34	HM001	
804D-18-72-S25	18	72.00	153	97	56	77	25	35	0.35	0.25	–	GI301	GI314	0.35	HM002	
804D-19-76-S25	19	76.00	157	101	56	81.5	25	35	0.15	0.45	–	GI301	GI314	0.36	HM002	
804D-20-80-S25	20	80.00	161	105	56	85	25	35	0.10	0.45	–	GI302	GI315	0.37	HM003	
804D-21-84-S25	21	84.00	165	109	56	89.5	25	35	0.10	0.50	–	GI302	GI315	0.39	HM003	
804D-22-88-S25	22	88.00	169	113	56	94	25	35	0.45	0.50	–	GI303	GI316	0.41	HM004	
804D-23-92-S25	23	92.00	173	117	56	98.5	25	35	0.35	0.50	–	GI304	GI317	0.44	HM005	
804D-24-96-S25	24	96.00	177	121	56	103	25	35	0.15	0.50	–	GI304	GI317	0.45	HM005	
804D-25-100-S32	25	100.00	185	125	60	105	32	42	0.15	0.50	–	GI304	GI317	0.67	HM005	
804D-26-104-S32	26	104.00	189	129	60	109.5	32	42	0.10	0.50	–	GI304	GI317	0.70	HM005	
804D-27-108-S32	27	108.00	193	133	60	114	32	42	0.50	0.30	–	GI305	GI318	0.71	HM006	
804D-28-112-S32	28	112.00	197	137	60	118.5	32	42	0.30	0.50	–	GI306	GI319	0.75	HM007	
804D-29-116-S32	29	116.00	201	141	60	123	32	42	0.20	0.50	–	GI306	GI319	0.78	HM007	
804D-30-120-S32	30	120.00	205	145	60	127.5	32	42	0.15	0.50	–	GI306	GI319	0.82	HM007	
804D-31-124-S32	31	124.00	209	149	60	132	32	42	0.15	0.50	–	GI306	GI319	0.85	HM007	
804D-32-128-S32	32	128.00	213	153	60	136.5	32	42	0.50	0.30	–	GI307	GI320	0.90	HM008	
804D-33-132-S32	33	132.00	217	157	60	141	32	42	0.50	0.50	–	GI307	GI320	0.95	HM008	
804D-34-136-S32	34	136.00	221	161	60	145.5	32	42	0.25	0.50	–	GI307	GI320	0.99	HM008	
804D-35-140-S32	35	140.00	225	165	60	149	32	42	0.25	0.50	–	GI308	GI321	1.04	HM009	
804D-36-144-S32	36	144.00	229	169	60	153.5	32	42	0.10	0.50	–	GI308	GI321	1.05	HM009	
804D-37-148-S32	37	148.00	233	173	60	158	32	42	0.10	0.50	–	GI308	GI321	1.11	HM009	
804D-38-152-S32	38	152.00	237	177	60	162.5	32	42	0.50	0.50	–	GI308	GI321	1.18	HM009	
804D-39-156-S32	39	156.00	241	181	60	167	32	42	0.40	0.50	–	GI309	GI322	1.25	HM009	
804D-40-160-S32	40	160.00	245	185	60	171.5	32	42	0.20	0.50	–	GI309	GI322	1.33	HM009	
804D-41-164-S40	41	164.00	259	189	70	172	40	50	0.20	0.50	–	GI309	GI322	1.68	HM009	
804D-42-168-S40	42	168.00	263	193	70	176.5	40	50	0.15	0.50	–	GI309	GI322	1.76	HM009	
804D-43-172-S40	43	172.00	267	197	70	181	40	50	0.10	0.50	–	GI309	GI322	1.83	HM009	



Produit	DC	APMX	OAL	LPR	LS	LU	DCON/MS	DF	$\overset{\uparrow}{\downarrow}D$	D^{\uparrow}					
	(mm)	(mm)	(mm)	(mm)	(mm)	(mm)	(mm)	(mm)	(mm)	(mm)					
804D-44-176-S40	44	176.00	271	201	70	185.5	40	50	0.50	0.50	-	GI310	GI323	1.91	HM010
804D-45-180-S40	45	180.00	275	205	70	187.5	40	55	0.50	0.50	-	GI311	GI324	2.02	HM010
804D-46-184-S40	46	184.00	279	209	70	192	40	55	0.50	0.50	-	GI311	GI324	2.12	HM010
804D-47-188-S40	47	188.00	283	213	70	196.5	40	55	0.50	0.50	-	GI311	GI324	2.22	HM010
804D-48-192-S40	48	192.00	287	217	70	201	40	55	0.50	0.50	-	GI311	GI324	2.33	HM010
804D-49-196-S40	49	196.00	291	221	70	205.5	40	55	0.30	0.50	-	GI311	GI324	2.45	HM010
804D-50-200-S40	50	200.00	295	225	70	208.5	40	58	0.15	0.50	-	GI311	GI324	2.58	HM010
804D-51-204-S40	51	204.00	299	229	70	213	40	58	0.15	0.50	-	GI311	GI324	2.68	HM010
804D-52-208-S40	52	208.00	303	233	70	217.5	40	58	0.50	0.50	-	GI312	GI325	2.64	HM010
804D-53-212-S40	53	212.00	307	237	70	222	40	58	0.50	0.50	-	GI312	GI325	2.76	HM010
804D-54-216-S40	54	216.00	311	241	70	226.5	40	58	0.50	0.50	-	GI312	GI325	2.90	HM010
804D-55-220-S40	55	220.00	315	245	70	231	40	58	0.50	0.50	-	GI312	GI325	3.00	HM010
804D-56-224-S40	56	224.00	319	249	70	235.5	40	58	0.50	0.50	-	GI312	GI325	3.15	HM010
804D-57-228-S40	57	228.00	323	253	70	240	40	58	0.35	0.50	-	GI312	GI325	3.30	HM010
804D-58-232-S40	58	232.00	327	257	70	244.5	40	58	0.15	0.50	-	GI312	GI325	3.46	HM010

GI300	XPET 0502AP	SCET 050204-UD
GI301	XPET 0602AP	SCET 050204-UD
GI302	XPET 0602AP	SCET 060204-UD
GI303	XPET 0703AP	SCET 060204-UD
GI304	XPET 0703AP	SCET 070308-UD
GI305	XPET 0903AP	SCET 070308-UD
GI306	XPET 0903AP	SCET 09T308-UD
GI307	XPET 11T3AP	SCET 09T308-UD
GI308	XPET 11T3AP	SCET 120408-UD
GI309	XPET 12T3AP	SCET 120408-UD
GI310	XPET 1504AP	SCET 120408-UD
GI311	XPET 1504AP	SCET 150512-UD
GI312	XPET 1904AP	SCET 150512-UD
GI313	XPET 0502AP-SD	SCET 050204-SD
GI314	XPET 0602AP-SD	SCET 050204-SD
GI315	XPET 0602AP-SD	SCET 060204-SD
GI316	XPET 0703AP-SD	SCET 060204-SD
GI317	XPET 0703AP-SD	SCET 070308-SD
GI318	XPET 0903AP-SD	SCET 070308-SD
GI319	XPET 0903AP-SD	SCET 09T308-SD
GI320	XPET 11T3AP-SD	SCET 09T308-SD
GI321	XPET 11T3AP-SD	SCET 120408-SD
GI322	XPET 12T3AP-SD	SCET 120408-SD
GI323	XPET 1504AP-SD	SCET 120408-SD
GI324	XPET 1504AP-SD	SCET 150512-SD
GI325	XPET 1904AP-SD	SCET 150512-SD

HM001	US 2245-T07P	0.9	US 2245-T07P	0.9	FLAG T07P
HM002	US 2205-T07P	0.9	US 2245-T07P	0.9	FLAG T07P
HM003	US 2205-T07P	0.9	US 2205-T07P	0.9	FLAG T07P
HM004	US 2506-T07P	1.2	US 2506-T07P	1.2	FLAG T07P
HM005	US 2507-T08P	1.2	US 3007-T08P	2.0	FLAG T08P
HM006	US 3007-T09P	2.0	US 3007-T09P	2.0	FLAG T09P
HM007	US 3007-T09P	2.0	US 3009-T09P	2.0	FLAG T09P
HM008	US 3510-T15P	3.0	US 3508-T15P	3.0	FLAG T15P
HM009	US 3510-T15P	3.0	US 5012-T15P	5.0	FLAG T15P
HM010	US 4011-T15P	3.5	US 5012-T15P	5.0	FLAG T15P



805D

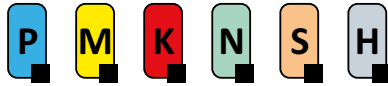

PRAMET

S



Corps de foret 805D 5xD à plaquettes indexables avec arrosage centralisé

Corps de foret à plaquettes indexables haute performance pour percer des trous borgnes et débouchants. Egalement pour perçage de trous sécants, décentrés et empilés, interpolation hélicoïdale, tréflage, perçage sur des surfaces concaves ou inclinées, perçage avec coupes interrompues, chanfreinage et alésage dans les paramètres de coupe recommandés. Disponible du Ø19 au Ø31 mm en 5xD.

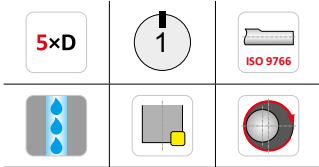
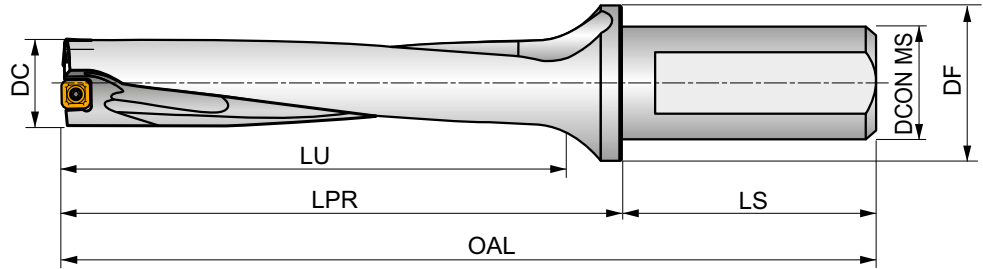

Produit	DC	APMX	OAL	LPR	LS	LU	DCON MS	DF	\bar{D}	D^+					
	(mm)	(mm)	(mm)	(mm)	(mm)	(mm)	(mm)	(mm)	(mm)	(mm)					
805D-19-95-S25	19	95.00	176	120	56	100.5	25	35	0.15	0.45	–	GI301	GI314	0.38	HM002
805D-20-100-S25	20	100.00	181	125	56	105	25	35	0.10	0.45	–	GI302	GI315	0.40	HM003
805D-21-105-S25	21	105.00	186	130	56	110.5	25	35	0.10	0.50	–	GI302	GI315	0.42	HM003
805D-22-110-S25	22	110.00	191	135	56	116	25	35	0.45	0.50	–	GI303	GI316	0.45	HM004
805D-23-115-S25	23	115.00	196	140	56	121.5	25	35	0.35	0.50	–	GI304	GI317	0.48	HM005
805D-24-120-S25	24	120.00	201	145	56	127	25	35	0.15	0.50	–	GI304	GI317	0.49	HM005
805D-25-125-S32	25	125.00	210	150	60	130	32	42	0.15	0.50	–	GI304	GI317	0.72	HM005
805D-26-130-S32	26	130.00	215	155	60	135.5	32	42	0.10	0.50	–	GI304	GI317	0.75	HM005
805D-27-135-S32	27	135.00	220	160	60	141	32	42	0.50	0.30	–	GI305	GI318	0.78	HM006
805D-28-140-S32	28	140.00	225	165	60	146.5	32	42	0.30	0.50	–	GI306	GI319	0.82	HM007
805D-29-145-S32	29	145.00	230	170	60	152	32	42	0.20	0.50	–	GI306	GI319	0.86	HM007
805D-30-150-S32	30	150.00	235	175	60	157.5	32	42	0.15	0.50	–	GI306	GI319	0.90	HM007
805D-31-155-S32	31	155.00	240	180	60	163	32	42	0.15	0.50	–	GI306	GI319	0.95	HM007

GI301	XPET 0602AP	SCET 050204-UD
GI302	XPET 0602AP	SCET 060204-UD
GI303	XPET 0703AP	SCET 060204-UD
GI304	XPET 0703AP	SCET 070308-UD
GI305	XPET 0903AP	SCET 070308-UD
GI306	XPET 0903AP	SCET 09T308-UD
GI314	XPET 0602AP-SD	SCET 050204-SD
GI315	XPET 0602AP-SD	SCET 060204-SD
GI316	XPET 0703AP-SD	SCET 060204-SD
GI317	XPET 0703AP-SD	SCET 070308-SD
GI318	XPET 0903AP-SD	SCET 070308-SD



GI319	XPET 0903AP-SD	SCET 09T308-SD

HM002	US 2205-T07P	0.9	US 2245-T07P	0.9	FLAG T07P
HM003	US 2205-T07P	0.9	US 2205-T07P	0.9	FLAG T07P
HM004	US 2506-T07P	1.2	US 2506-T07P	1.2	FLAG T07P
HM005	US 2507-T08P	1.2	US 3007-T08P	2.0	FLAG T08P
HM006	US 3007-T09P	2.0	US 3007-T09P	2.0	FLAG T09P
HM007	US 3007-T09P	2.0	US 3009-T09P	2.0	FLAG T09P



EP

**EP - Douille de réglage de foret à plaquettes indexables**

Douille pour ajuster le diamètre du foret à plaquettes indexables. Peut être utilisée dans les porte-outils weldon Ø32 ou Ø40 mm. Le diamètre extérieur du foret est ajusté en tournant la douille.

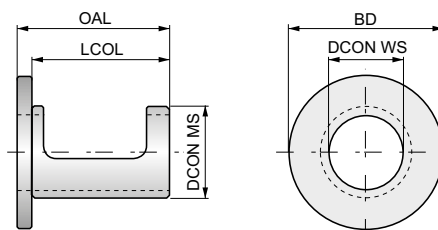

Plage de réglage du diamètre 0.4 – -0.2; plage de réglage de la hauteur de centre 0.2 – -0.15.

Produit	DCON WS	DCON MS	BD	OAL	LCOL	
	(mm)	(mm)	(mm)	(mm)	(mm)	
EP253253	25.00	32.00	53.00	53.0	48	0.15
EP324058	32.00	40.00	58.00	58.0	53	0.20



SCET

	IC (mm)	D1 (mm)	L (mm)	S (mm)
0502	5.556	2.40	5.56	2.38
0602	6.350	2.90	6.35	2.38
0703	7.937	3.50	7.94	3.18
09T3	9.525	4.50	9.53	3.97
1204	12.700	5.60	12.70	4.76
1505	15.875	5.60	15.88	5.56

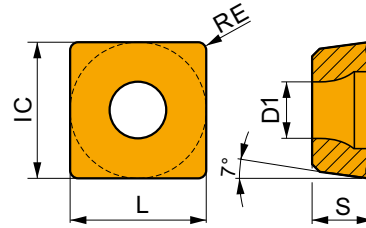

Adéquation et valeurs de départ pour la vitesse de coupe (vc), l'avance (f) et la profondeur de coupe (ap). Reportez-vous à notre application "Calculators" pour d'autres calculs.

Produit	RE (mm)	P			M			K			N			S			H		
		vc (m/min)	f (mm/rev)	ap (mm)	vc (m/min)	f (mm/rev)	ap (mm)	vc (m/min)	f (mm/rev)	ap (mm)	vc (m/min)	f (mm/rev)	ap (mm)	vc (m/min)	f (mm/rev)	ap (mm)			

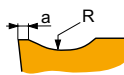

Géométrie UD avec coupe universelle pour plaquettes périphériques.

SCET 050204-UD 0,12
 SCET 060204-UD 0,15
 SCET 070308-UD 0,15
 SCET 09T308-UD 0,15
 SCET 120408-UD 0,20
 SCET 150512-UD 0,20

SCET 050204-UD	D8330	0.4	165	0.08	-	-	-	-	155	0.08	-	-	-	-	-	-	-	-
	D9335	0.4	240	0.08	-	-	-	-	225	0.08	-	-	-	-	-	-	-	-
SCET 060204-UD	D8330	0.4	165	0.11	-	-	-	-	155	0.11	-	-	-	-	-	-	-	-
	D9335	0.4	240	0.11	-	-	-	-	225	0.11	-	-	-	-	-	-	-	-
SCET 070308-UD	D8330	0.8	165	0.13	-	-	-	-	155	0.13	-	-	-	-	-	-	-	-
	D9335	0.8	240	0.13	-	-	-	-	225	0.13	-	-	-	-	-	-	-	-
SCET 09T308-UD	D8330	0.8	165	0.14	-	-	-	-	155	0.14	-	-	-	-	-	-	-	-
	D9335	0.8	240	0.14	-	-	-	-	225	0.14	-	-	-	-	-	-	-	-
SCET 120408-UD	D8330	0.8	165	0.16	-	-	-	-	155	0.16	-	-	-	-	-	-	-	-
	D9335	0.8	240	0.16	-	-	-	-	225	0.16	-	-	-	-	-	-	-	-
SCET 150512-UD	D8330	1.2	165	0.18	-	-	-	-	155	0.18	-	-	-	-	-	-	-	-
	D9335	1.2	240	0.18	-	-	-	-	225	0.18	-	-	-	-	-	-	-	-

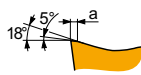

Géométrie SD avec coupe positive pour plaquettes périphériques.

SCET 050204-SD 0,04
 SCET 060204-SD 0,06
 SCET 070308-SD 0,08
 SCET 09T308-SD 0,10
 SCET 120408-SD 0,10
 SCET 150512-SD 0,10

SCET 050204-SD	D8330	0.4	165	0.08	-	95	0.07	-	155	0.08	-	-	-	40	0.06	-	-	-
	D9335	0.4	240	0.08	-	140	0.07	-	225	0.08	-	-	-	60	0.06	-	-	-
SCET 060204-SD	D8330	0.4	165	0.11	-	95	0.09	-	155	0.11	-	-	-	40	0.07	-	-	-
	D9335	0.4	240	0.11	-	140	0.09	-	225	0.11	-	-	-	60	0.07	-	-	-
SCET 070308-SD	D8330	0.8	165	0.13	-	95	0.11	-	155	0.13	-	-	-	40	0.09	-	-	-
	D9335	0.8	240	0.13	-	140	0.11	-	225	0.13	-	-	-	60	0.09	-	-	-
SCET 09T308-SD	D8330	0.8	165	0.14	-	95	0.13	-	155	0.14	-	-	-	40	0.10	-	-	-
	D9335	0.8	240	0.14	-	140	0.13	-	225	0.14	-	-	-	60	0.10	-	-	-
SCET 120408-SD	D8330	0.8	165	0.16	-	95	0.14	-	155	0.16	-	-	-	40	0.11	-	-	-
	D9335	0.8	240	0.16	-	140	0.14	-	225	0.16	-	-	-	60	0.11	-	-	-
SCET 150512-SD	D8330	1.2	165	0.18	-	95	0.16	-	155	0.18	-	-	-	40	0.12	-	-	-
	D9335	1.2	240	0.18	-	140	0.16	-	225	0.18	-	-	-	60	0.12	-	-	-



XPET



	IC	D1	L	S
	(mm)	(mm)	(mm)	(mm)
0502	5.556	2.40	5.56	2.38
0602	6.350	2.60	6.35	2.38
0703	7.937	2.90	7.94	3.18
0903	9.525	3.50	9.53	3.18
11T3	11.509	3.90	11.50	3.97
12T3	12.700	3.90	12.70	3.97
1504	15.875	4.50	15.88	4.76
1904	19.050	4.50	19.05	4.76

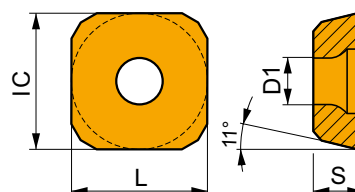

Adéquation et valeurs de départ pour la vitesse de coupe (vc), l'avance (f) et la profondeur de coupe (ap). Reportez-vous à notre application "Calculators" pour d'autres calculs.

Produit	RE (mm)	P			M			K			N			S			H		
		vc (m/min)	f (mm/rev)	ap (mm)	vc (m/min)	f (mm/rev)	ap (mm)	vc (m/min)	f (mm/rev)	ap (mm)	vc (m/min)	f (mm/rev)	ap (mm)	vc (m/min)	f (mm/rev)	ap (mm)	vc (m/min)	f (mm/rev)	ap (mm)

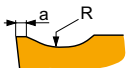

Géométrie avec coupe universelle pour plaquettes centrales.

XPET 0502AP	0,10
XPET 0602AP	0,10
XPET 0703AP	0,15
XPET 0903AP	0,25
XPET 11T3AP	0,25
XPET 12T3AP	0,25
XPET 1504AP	0,25
XPET 1904AP	0,25

XPET 0502AP	D8345	-	165	0.08	-	-	-	-	155	0.08	-	-	-	-	-	-	-	-	-
XPET 0602AP	D8345	-	165	0.11	-	-	-	-	155	0.11	-	-	-	-	-	-	-	-	-
XPET 0703AP	D8345	-	165	0.13	-	-	-	-	155	0.13	-	-	-	-	-	-	-	-	-
XPET 0903AP	D8345	-	165	0.14	-	-	-	-	155	0.14	-	-	-	-	-	-	-	-	-
XPET 11T3AP	D8345	-	165	0.16	-	-	-	-	155	0.16	-	-	-	-	-	-	-	-	-
XPET 12T3AP	D8345	-	165	0.16	-	-	-	-	155	0.16	-	-	-	-	-	-	-	-	-
XPET 1504AP	D8345	-	165	0.18	-	-	-	-	155	0.18	-	-	-	-	-	-	-	-	-
XPET 1904AP	D8345	-	165	0.18	-	-	-	-	155	0.18	-	-	-	-	-	-	-	-	-

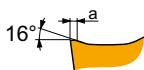

Géométrie SD avec coupe positive pour plaquettes centrales.

XPET 0502AP-SD	0,04
XPET 0602AP-SD	0,05
XPET 0703AP-SD	0,08
XPET 0903AP-SD	0,10
XPET 11T3AP-SD	0,10
XPET 12T3AP-SD	0,10
XPET 1504AP-SD	0,10
XPET 1904AP-SD	0,12

XPET 0502AP-SD	D8345	-	165	0.08	-	95	0.07	-	155	0.08	-	-	-	-	40	0.06	-	-	-
XPET 0602AP-SD	D8345	-	165	0.11	-	95	0.09	-	155	0.11	-	-	-	-	40	0.07	-	-	-
XPET 0703AP-SD	D8345	-	165	0.13	-	95	0.11	-	155	0.13	-	-	-	-	40	0.09	-	-	-
XPET 0903AP-SD	D8345	-	165	0.14	-	95	0.13	-	155	0.14	-	-	-	-	40	0.10	-	-	-
XPET 11T3AP-SD	D8345	-	165	0.16	-	95	0.14	-	155	0.16	-	-	-	-	40	0.11	-	-	-
XPET 12T3AP-SD	D8345	-	165	0.16	-	95	0.14	-	155	0.16	-	-	-	-	40	0.11	-	-	-
XPET 1504AP-SD	D8345	-	165	0.18	-	95	0.16	-	155	0.18	-	-	-	-	40	0.12	-	-	-
XPET 1904AP-SD	D8345	-	165	0.18	-	95	0.16	-	155	0.18	-	-	-	-	40	0.12	-	-	-









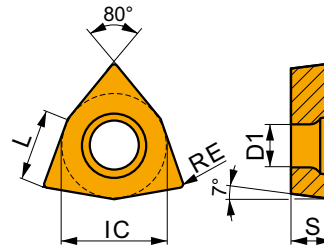

WCMT-ID

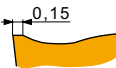

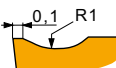
	IC	D1	L	S
	(mm)	(mm)	(mm)	(mm)
0402	6.350	2.90	4.30	2.38
0503	7.938	3.50	5.40	3.18
06T3	9.525	4.40	6.50	3.97
0804	12.700	5.50	8.70	4.76

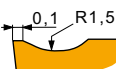

Adéquation et valeurs de départ pour la vitesse de coupe (vc), l'avance (f) et la profondeur de coupe (ap). Reportez-vous à notre application "Calculators" pour d'autres calculs.

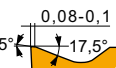
Produit	RE (mm)	P			M			K			N			S			H		
		vc (m/min)	f (mm/rev)	ap (mm)	vc (m/min)	f (mm/rev)	ap (mm)	vc (m/min)	f (mm/rev)	ap (mm)	vc (m/min)	f (mm/rev)	ap (mm)	vc (m/min)	f (mm/rev)	ap (mm)	vc (m/min)	f (mm/rev)	ap (mm)
 																			
WCMT 06T308E-45	D8330 0.8	165	0.15	-	95	0.14	-	155	0.15	-	-	-	-	-	-	-	-	-	-
 																			
WCMT 040208E-46	D8330 0.8	165	0.15	-	95	0.14	-	155	0.15	-	-	-	-	-	-	-	-	-	-
 																			
WCMT 050308E-47	D8330 0.8	165	0.20	-	95	0.18	-	155	0.20	-	-	-	-	-	-	-	-	-	-
 																			
WCMT 080412E-48	D8330 1.2	165	0.22	-	95	0.22	-	155	0.22	-	-	-	-	-	-	-	-	-	-
 																			
WCMT 040208E-UM	D8330 0.8	165	0.20	-	95	0.18	-	155	0.20	-	-	-	-	-	-	-	-	-	-
WCMT 050308E-UM	D8330 0.8	165	0.20	-	95	0.18	-	155	0.20	-	-	-	-	-	-	-	-	-	-







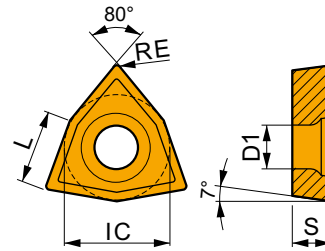

WCMX

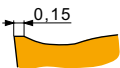

	IC	D1	L	S
	(mm)	(mm)	(mm)	(mm)
0302	5.556	2.85	3.80	2.38
0402	6.350	3.15	4.30	2.38
0503	7.938	3.20	5.40	3.18
06T3	9.525	3.72	6.50	3.97
0804	12.700	4.30	8.70	4.76



Adéquation et valeurs de départ pour la vitesse de coupe (vc), l'avance (f) et la profondeur de coupe (ap). Reportez-vous à notre application "Calculators" pour d'autres calculs.

Produit	RE (mm)	P			M			K			N			S			H						
		vc (m/min)	f (mm/rev)	ap (mm)	vc (m/min)	f (mm/rev)	ap (mm)	vc (m/min)	f (mm/rev)	ap (mm)	vc (m/min)	f (mm/rev)	ap (mm)	vc (m/min)	f (mm/rev)	ap (mm)	vc (m/min)	f (mm/rev)	ap (mm)				
		U		S		Géométrie 45 pour l'usinage de la finition à l'ébauche avec des coupes continues à interrompues.																	
WCMX 06T308E-15	D8330 0.8	165	0.15	-	95	0.14	-	155	0.15	-	-	-	-	-	-	-	-	-	-				
		U		S		Géométrie 46 pour l'usinage de précision ou de finition avec des coupes continues à interrompues.																	
WCMX 030208E-16	D8330 0.8	165	0.15	-	95	0.14	-	155	0.15	-	-	-	-	-	-	-	-	-	-				
WCMX 040208E-16	D8330 0.8	165	0.15	-	95	0.14	-	155	0.15	-	-	-	-	-	-	-	-	-	-				
		U		S		Géométrie 47 pour l'usinage de finition à semi-ébauche avec des coupes continues à interrompues.																	
WCMX 050308E-17	D8330 0.8	165	0.20	-	95	0.18	-	155	0.20	-	-	-	-	-	-	-	-	-	-				
		U		S		Géométrie 48 pour l'usinage de finition à semi-ébauche avec des coupes continues à interrompues.																	
WCMX 080412E-18	D8330 1.2	165	0.22	-	95	0.20	-	155	0.22	-	-	-	-	-	-	-	-	-	-				



PERÇAGE
INFORMATIONS TECHNIQUES

GROUPES DE MATÉRIAUX À USINER (WMG)

ISO Pour sélectionner une nuance et une géométrie convenant à une large gamme de matériaux à usiner

Définition générale
acier, acier inoxydable, etc.

P **M** **K** **N** **S** **H**

Sous-groupe Pour parcourir et choisir un outil adapté à une gamme plus spécifique de matériaux à usiner

Définition en fonction de la structure/composition
acier simple au carbone, acier spécial, etc.

P **M** **K** **N** **S** **H**

P1

P2

P3

P4

WMG Pour choisir et respecter des conditions de coupe données avec une marge de ±10 %

Définition en fonction de la dureté/résistance à la traction max.
160 < 220 HB, 620 < 900 n/mm²; etc.

P

P1 **P1.1** **P1.2** **P1.3**

P2 **P2.1** **P2.2** **P2.3**

P3 **P3.1** **P3.2** **P3.3**

P4 **P4.1** **P4.2** **P4.3**

À PROPOS DE LA CLASSIFICATION DES MATÉRIAUX À USINER DE DORMER PRAMET

Les groupes de matériaux à usiner (WMG pour Workpiece Material Groups) permettent de choisir plus facilement et en toute assurance le bon outil de coupe avec les valeurs de départ adaptées aux conditions d'un usinage particulier.

Dormer Pramet classe les matériaux à usiner en six groupes de couleurs différentes :

- **Bleu**: aciers et aciers moulés (groupe P)
- **Jaune**: aciers inoxydables (groupe M)
- **Rouge**: fontes (groupe K)
- **Vert**: métaux non ferreux (groupe N)
- **Brun** : alliages haute température (groupe S)
- **Gris**: matériaux durs (groupe H)

Chacun de ces groupes se divise en sous-groupes en fonction de la structure et/ou de la composition des matériaux. Par exemple, les aciers et aciers moulés du groupe P sont classés en quatre sous-groupes, comme suit :

- **P1: acier de décolletage**
- **P2: acier simple au carbone**
- **P3: acier allié**
- **P4: acier à outil**

Un dernier classement se fait en fonction des propriétés du matériau, comme sa dureté et sa résistance à la traction maximale. Nos clients peuvent ainsi choisir l'outil le mieux adapté à leur application et ils disposent des valeurs de vitesse de coupe et d'avance initiales.

Le tableau de la page suivante comprend une description de chaque groupe de matériaux à usiner ainsi que des exemples, avec des désignations courantes.



GROUPES DE MATÉRIAUX À USINER (WMG)

Groupes de matériaux à usiner (WMG)	k_{vc}	Exemples de matériaux (AISI, EN, DIN, ČSN, GB, SS, STN, BS, UNE, AFNOR, ASTM, GOST, UNS, UNI, etc.)
P1 Acier de décolletage (aciers au carbone, usinabilité accrue)	P1.1	Acier de décolletage au carbone et manganèse d'une dureté < 240 HB
	P1.2	Acier de décolletage au carbone, manganèse et phosphore d'une dureté < 180 HB
	P1.3	Acier de décolletage au carbone, manganèse, phosphore et plomb d'une dureté < 180 HB
P2 Acier simple au carbone (aciers principalement composés de fer et de carbone)	P2.1	Acier simple à faible teneur en carbone < 0,25 % d'une dureté < 180 HB
	P2.2	Acier simple à teneur moyenne en carbone < 0,55 % d'une dureté < 240 HB
	P2.3	Acier simple à forte teneur en carbone < 0,55 % d'une dureté < 300 HB
P3 Acier allié (aciers au carbone avec une teneur en alliage ≤ 10 %)	P3.1	Acier allié d'une dureté < 180 HB
	P3.2	Acier allié d'une dureté 180-260 HB
	P3.3	Acier allié d'une dureté 260-360 HB
P4 Acier à outil (acier allié spécial pour outils, moules et matrices)	P4.1	Acier à outil d'une dureté < 26 HRC
	P4.2	Acier à outil d'une dureté 26-39 HRC
	P4.3	Acier à outil d'une dureté 39-45 HRC



GROUPES DE MATÉRIAUX À USINER (WMG)

Groupes de matériaux à usiner (WMG)	k _{vg}	Exemples de matériaux (AISI, EN, DIN, ČSN, GB, SS, STN, BS, UNE, AFNOR, ASTM, GOST, UNS, UNI, etc.)
M1 Acier inoxydable ferritique (alliages non durcissables au chrome droit)	M1.1 Acier inoxydable, ferritique d'une dureté < 160 HB	1.22 AISI 5429, EN X7Cr14, DIN 1.4001, SS 2326, BS 434517, UNE F.3401, AFNOR Z8C12, GOST 08Ch13, UNI X6CrTi12
	M1.2 Acier inoxydable, ferritique d'une dureté 160-220 HB	1.03 AISI 446, EN X10CrAl24, DIN 1.4762, SS 2322, ČSN 17113, BS 430517, UNE F.3154, GB 10Cr17, AFNOR Z10CA524, GOST 12Ch17, UNI X16Cr26
M2 Acier inoxydable martensitique (alliages durcissables au chrome droit)	M2.1 Acier inoxydable, martensitique d'une dureté < 200 HB	1.08 AISI 430F, EN X14CrMo517, DIN 1.4104, SS 2383, ČSN 17140, BS 410521, UNE F.3117, AFNOR Z10CF17, UNI X10Cr517
	M2.2 Acier inoxydable, martensitique d'une dureté 200-280 HB	0.89 AISI 440C, EN X105CrMo17, DIN 1.4125, SS 2385, ČSN 17023, BS 425C11, UNE F.3402, GB 102Cr17Mo, AFNOR Z100CD17, GOST 95Ch18, UNI 6X6CrNi 13 04
M3 Acier inoxydable austénitique (alliages chrome-nickel et chrome-nickel-manganèse)	M3.1 Acier inoxydable, austénitique d'une dureté < 200 HB	0.75 AISI 420, EN X45Cr13, DIN 1.4034, ČSN 17029, BS 425C11, UNE F.3405, AFNOR Z44C14, GOST 20X17H12, UNI X30Cr13
	M3.2 Acier inoxydable, austénitique d'une dureté 200-260 HB	1.00 AISI 304, EN X5CrNi18-12, DIN 1.4303, SS 2352, ČSN 17249, BS 305517, UNE F.3513, GB 10Cr18Ni12, AFNOR Z8CN18.12, UNI X7CrNi18 10
M4 Acier inoxydable super-austénitique (duplex) à durcissement par précipitation (alliages austénitiques > 20 % Ni, micro-structure austéno-ferritique ou durci par précipitation)	M3.3 Acier inoxydable, austénitique d'une dureté 260-300 HB	0.86 AISI 309, EN X15CrNiSi20-12, DIN 1.4828, ČSN 17251, BS 309S24, UNE F.3312, GB 1G23Ni13, AFNOR Z15CNS20.12, GOST 20Ch20Ni452, UNI 16CrNi23 14
	M4.1 Acier inoxydable, austénitique-ferritique ou super-austénitique d'une dureté < 300 HB	0.77 AISI 5848, EN X45CrNiW18-9, DIN 1.4873, BS 331540, UNE F.3211, AFNOR Z35CNW514-4, UNI X45CrNiW 18 9
M4.2 Acier inoxydable, austénitique à durcissement par précipitation d'une dureté 300-380 HB	M4.1 Acier inoxydable, austénitique-ferritique ou super-austénitique d'une dureté < 300 HB	0.75 AISI 329, EN X1-NiCrMoCu25-20-5, DIN 1.4539, SS 2562, ČSN 17265, BS 318513, UNE F.3552, GB 022Cr25NiMo2N, AFNOR Z1NCUD25.20
	M4.2 Acier inoxydable, austénitique à durcissement par précipitation d'une dureté 300-380 HB	0.64 AISI 631 (17-7PH), EN X7CrNiAl17-7, DIN 1.4568, SS 2388, ČSN 17465, BS 301513, UNE F.3217, GB 07Cr17Ni7Al, AFNOR Z9CNA17-07, GOST 09Ch17Ni7Al, UNI X53CrMnNi21 9



GROUPES DE MATÉRIAUX À USINER (WMG)

Groupes de matériaux à usiner (WMG)	k_{vc}	Exemples de matériaux (AISI, EN, DIN, ČSN, GB, SS, STN, BS, UNE, AFNOR, ASTM, GOST, UNS, UNI, etc.)
K1 Fonte grise (GG) (pièces moulées en fer-carbone avec micro-structure graphite lamellaire)	K1.1	Fonte grise, ferritique ou ferritique-perlitique d'une dureté < 180 HB
	K1.2	Fonte grise, ferritique-perlitique ou perlitique d'une dureté 180-240 HB
	K1.3	Fonte grise, perlitique d'une dureté 240-280 HB
K2 Fonte malléable (GTS/GTW) (pièces moulées en fer-carbone thermotraitée avec micro-structure sans graphite)	K2.1	Fonte malléable, ferritique d'une dureté < 160 HB
	K2.2	Fonte malléable, ferritique ou perlitique d'une dureté 160-200 HB
	K2.3	Fonte malléable, perlitique d'une dureté 200-240 HB
K3 Fonte malléable (GGG) (pièces moulées en fer-carbone avec micro-structure en graphite nodulaire)	K3.1	Fonte malléable (nodulaire/sphéroïdale), ferritique d'une dureté < 180 HB
	K3.2	Fonte malléable (nodulaire/sphéroïdale), ferritique ou perlitique d'une dureté 180-220 HB
	K3.3	ou perlitique, perlitique d'une dureté 220-260 HB
K4 Fonte malléable austénitique ou à trempe étagée (rés. Ni/ADI) (alliage fer-carbone avec micro-structure austénitique ou ausferritique)	K4.1	Fonte austénitique d'une dureté < 180 HB
	K4.2	Fonte austénitique d'une dureté 180-240 HB
	K4.3	Fonte malléable à trempe étagée d'une dureté 240-280 HB
K5 Fonte à graphite vermiculaire compactée (CGI) (pièces moulées en fer-carbone avec structure graphite vermiculaire)	K4.4	Fonte malléable à trempe étagée d'une dureté 280-320 HB
	K4.5	Fonte malléable à trempe étagée d'une dureté 320-360 HB
	K5.1	Fonte à graphite vermiculaire compactée d'une dureté < 180 HB
K5 Fonte à graphite vermiculaire compactée (CGI) (pièces moulées en fer-carbone avec structure graphite vermiculaire)	K5.2	Fonte à graphite vermiculaire compactée d'une dureté 180-220 HB
	K5.3	Fonte à graphite vermiculaire compactée d'une dureté 220-260 HB
	K5.3	Fonte à graphite vermiculaire compactée d'une dureté 220-260 HB



GROUPES DE MATÉRIAUX À USINER (WMG)

Groupe ISO	Sous-groupe	Groupes de matériaux à usiner (WMG)	k_{vg}	Exemples de matériaux (AISI, EN, DIN, ČSN, GB, SS, STN, BS, UNE, AFNOR, ASTM, GOST, UNS, UNI, etc.)	
N Métaux non ferreux (métaux, y compris les alliages sans quantité appréciable de fer)	N1 Aluminium corroyé	N1.1 Aluminium pur et alliages d'aluminium moulés d'une dureté < 60 HB	1.33	UNS A91200, EN AL99.6, DIN 3.0205, SS 4010, STN 424009, BS 1C, UNE L-3001, GB L5, AFNOR A4, GOST A1C, UNI 3567	
		N1.2 Alliages d'aluminium corroyé d'une dureté 60-100 HB	1.00	UNS A93004, EN AlMn0.5Mg0.5, DIN 3.0505, SS 4054, STN 424432, BS N31, UNE L-3831, GB LF2, AFNOR A-M1, GOST AM14, UNI 3568	
		N1.3 Alliages d'aluminium corroyé d'une dureté 100-150 HB	0.67	UNS A95083, EN AlMg4.5Mn0.7, DIN 3.3547, SS 4140, STN 424415, BS N8, UNE L-3321, GB AlMg4.5Mn, AFNOR A-G4.5Mn, GOST Amg 4.5, UNI P-AlMg4.4	
	N2 Aluminium moulé	N2.1 Alliages d'aluminium moulé d'une dureté < 75 HB	Alliages d'aluminium moulé d'une dureté < 75 HB	0.67	UNS A02080, EN AlCu45, BS LM11, STN 424331, UNE AlSi1Cu, GOST AMg5K, UNI G-AlSi7Mg
		N2.2 Alliages d'aluminium moulé d'une dureté 75-90 HB	Alliages d'aluminium moulé d'une dureté 75-90 HB	0.60	UNS A02420, EN AlCu4Ni2Mg2, SS AlSi7MgFe, BS LM6, STN 424519, UNE Al-7SiMg, AFNOR A-S7G, GOST AK7, UNI G-AlSi7Mg
		N2.3 Alliages d'aluminium moulé d'une dureté 90 < 140 HB	Alliages d'aluminium moulé d'une dureté 90 < 140 HB	0.43	UNS A03360, EN G-ALCu4NiMg2, SS AlSi10Mg, STN 424336, BS LM 30, AFNOR A-S10G, UNI G-AlSi9Mg
	N3 Cuivre ou alliages de cuivre	N3.1 Alliages de cuivre de décolletage avec d'excellentes propriétés d'usinage	Alliages de cuivre de décolletage avec d'excellentes propriétés d'usinage	0.70	UNS C14700, EN CuPb1P, DIN 2.1498, STN 423214, BS C111, AFNOR CuZn35Pb2, GOST L63-3, UNI CuS(P0.01)
		N3.2 Alliages de cuivre à copeaux courts avec des propriétés d'usinage bonnes à moyennes	Alliages de cuivre à copeaux courts avec des propriétés d'usinage bonnes à moyennes	0.41	UNS C81540, EN CuNi25Cr, DIN 2.0857, STN 423220, BS NS113, UNE CuSn12, AFNOR CuZn40, GOST L60, UNI P-CuZn-40
		N3.3 Alliages de cuivre à longs copeaux et cuivre électrolytique avec des propriétés d'usinage médianes à moyennes	Alliages de cuivre à longs copeaux et cuivre électrolytique avec des propriétés d'usinage médianes à moyennes	0.21	UNS C10100, EN CuAg0.1, DIN 2.1203, SS 5010, UNE CUSi3Mn1, AFNOR Cu-C2, GOST M1f, UNI Cu-0F
	N4 Polymères (matériaux synthétiques ou semi-synthétiques)	N4.1 Polymères et thermoplastiques	Polymères et thermoplastiques	0.70	ABS, Acryl, Duraplast, Elastomer, EP, Epoxid, FEP, Fluor, Gummi, Kautschuk, Latex, ME, MPF, PA, PAl, PC, PE, PEEK, PEI, PES, PET, PF, Phenolharze, PI, PMMA, Polyamide, Polyester, Polyolefine, Polysulfon, POM, PP, PPE, PPS, PS, PSU, PTFE, PU, PUR, PVDF, SAN, SI, Styrol, UF, Ureol
		N4.2 Polymères thermodurcissables	Polymères thermodurcissables	0.27	Aramid, Epoxy, Fluoropolymer, Meacrylate, Melamine, Phenolic, Polyester, Polyimide, Polymethacrylimide, Polyurethane
		N4.3 Polymères renforcés ou composites	Polymères renforcés ou composites	0.29	CFK, GFK, GMT, Honeycomb, Kevlar, LFT, Organo, SMC
N5 Graphite	N5.1	N5.1	1.0	CGM-1, CM-00, GM-10, GM-11, GR030, GR030PI, GR060, GR060PI, GR125, MC-01, MC-01R0, MC-03, MC-03M, IG11, IG-15, IG-32, IG-43, IG-45, IG-70, ISEM-1, ISEM-2, ISEM-3, R8340, R8500X, Technograph 15, Technograph 30, ISO-63, EDM C-3, EDM1, EDM3, ISO-90, ISO-93, ISO-95, R8510, R8650, R8650	



GROUPES DE MATÉRIAUX À USINER (WMG)

Groupes de matériaux à usiner (WMG)	k_{wg}	Exemples de matériaux (AISI, EN, DIN, ČSN, GB, SS, STN, BS, UNE, AFNOR, ASTM, GOST, UNS, UNI, etc.)
S1 Titane ou alliages de titane	S1.1	Titane ou alliages de titane d'une dureté < 200 HB 1.94
	S1.2	Alliages de titane d'une dureté 200-280 HB 1.72
	S1.3	Alliages de titane d'une dureté 280-360 HB 1.44
S2 Alliages à base de fer haute température	S2.1	Alliages à base de fer haute température d'une dureté < 200 HB 1.33
	S2.2	Alliages à base de fer haute température d'une dureté 200-280 HB 1.17
S3 Alliages à base de nickel haute température	S3.1	Alliages à base de nickel haute température d'une dureté < 280 HB 1.00
	S3.2	Alliages à base de nickel haute température d'une dureté 280-360 HB 0.83
S4 Alliages à base de cuivre haute température	S4.1	Alliages à base de cuivre haute température d'une dureté < 240 HB 0.78
	S4.2	Alliages à base de cuivre haute température d'une dureté 240-320 HB 0.67

Alliages haute température

(superalloys dont la résistance thermique et à la corrosion est supérieure à celle de l'acier inoxydable)

S



GROUPES DE MATÉRIAUX À USINER (WVG)

Groupe ISO	Sous-groupe	Groupes de matériaux à usiner (WVG)	k_{vg}	Exemples de matériaux (AISI, EN, DIN, ČSN, GB, SS, STN, BS, UNE, AFNOR, ASTM, GOST, UNS, UNI, etc.)
H Matériaux trempés (tout métal d'ingénierie ayant une dureté > 45 HRC)	H1 Fonte en coquille	H1.1 Fonte en coquille d'une dureté < 440 HB	1.52	UNS F45001, EN-GJS-1050-6, DIN 5.3406, SS 0512, BS Grade 2A
		H2.1 Fonte trempée d'une dureté < 55 HRC	0.90	UNS F45003, EN-GJS-1400-1, DIN 5.3405, SS 0457, BS Grade 3D
	H2 Fonte trempée	H2.2 Fonte trempée d'une dureté > 55 HRC	0.77	UNS F45003, EN G-X260NiCr4-2, DIN 0.9620, SS 0466, BS Grade S
		H3.1 Acier trempé d'une dureté < 51 HRC	1.00	AISI 4135, EN 34CrMo4, DIN 1.7220, SS 2234, STN 415131, BS 198, UNE F.1250, GB 35CrMo, AFNOR 35CD4, GOST AC38XTM, UNI 35CrMo4KB
	H3 Acier trempé < 55 HRC	H3.2 Acier trempé d'une dureté 51-55 HRC	0.82	AISI 4135, EN 34CrMo4, DIN 1.7220, SS 2234, STN 415131, BS 198, UNE F.1250, GB 35CrMo, AFNOR 35CD4, GOST AC38XTM, UNI 35CrMo4KB
		H4.1 Acier trempé d'une dureté 55-59 HRC	0.64	UNS T31501, EN 100MnCrW4, DIN 1.2510, SS 2140, STN 419413, BS B01, UNE F.5220, GB 9CrWMn, AFNOR 90MnWCrV5, GOST 9XBТ, UNI 95MnWCr5KU
	H4 Acier trempé > 55 HRC	H4.2 Acier trempé d'une dureté > 59 HRC	0.54	UNS T31501, EN 100MnCrW4, DIN 1.2510, SS 2140, STN 419413, BS B01, UNE F.5220, GB 9CrWMn, AFNOR 90MnWCrV5, GOST 9XBТ, UNI 95MnWCr5KU

GÉOMÉTRIE DES PLAQUETTES

45

P	M	K	N	S	H
■	▣	■	■	■	■

Voir diagramme

? WCMT 06, WCMX 06

46

P	M	K	N	S	H
■	▣	■	■	■	■

Voir diagramme

? WCMT 04, WCMX 03, WCMX 04

47

P	M	K	N	S	H
■	▣	■	■	■	■

Voir diagramme

? WCMT 05, WCMX 05

48

P	M	K	N	S	H
■	▣	■	■	■	■

Voir diagramme

? WCMT 08, WCMX 08

GÉOMÉTRIE DES PLAQUETTES

UM

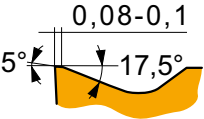
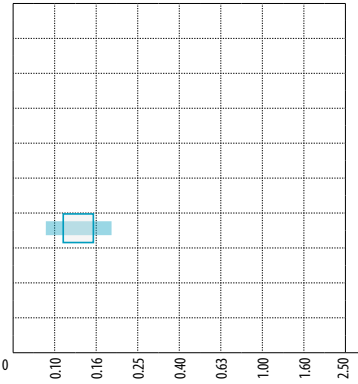
0 0,10 0,16 0,25 0,40 0,63 1,00 1,60 2,50

P **M** **K** **N** **S** **H**

Voir diagramme

? WCMT 04, WCMT 05

SCET.....-UD

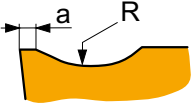
	a
SCET 050204-UD	0,12
SCET 060204-UD	0,15
SCET 070308-UD	0,15
SCET 09T308-UD	0,15
SCET 120408-UD	0,20
SCET 150512-UD	0,20

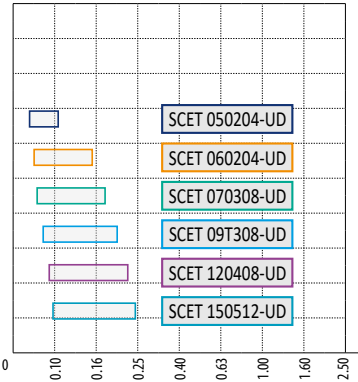

0 0,10 0,16 0,25 0,40 0,63 1,00 1,60 2,50

P **M** **K** **N** **S** **H**

Voir diagramme

? SCET.....-UD

XPET.....AP

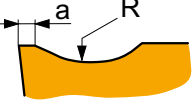
	a
XPET 0502AP	0,10
XPET 0602AP	0,10
XPET 0703AP	0,15
XPET 0903AP	0,25
XPET 11T3AP	0,25
XPET 12T3AP	0,25
XPET 1504AP	0,25
XPET 1904AP	0,25

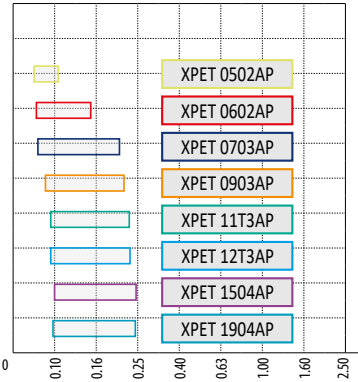

0 0,10 0,16 0,25 0,40 0,63 1,00 1,60 2,50

P **M** **K** **N** **S** **H**

Voir diagramme

? XPET.....AP

GÉOMÉTRIE DES PLAQUETTES

SCET - SD

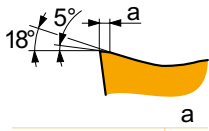

SCET 050204-SD	0,04
SCET 060204-SD	0,06
SCET 070308-SD	0,08
SCET 09T308-SD	0,10
SCET 120408-SD	0,10
SCET 150512-SD	0,10

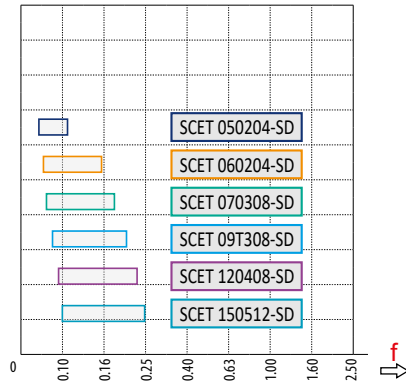

P	M	K	N	S	H
■	■	▣	■	▣	■
f → Voir diagramme					
SCET - SD					

XPETAP-SD

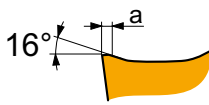

XPET 0502AP-SD	0,04
XPET 0602AP-SD	0,05
XPET 0703AP-SD	0,08
XPET 0903AP-SD	0,10
XPET 11T3AP-SD	0,10
XPET 12T3AP-SD	0,10
XPET 1504AP-SD	0,10
XPET 1904AP-SD	0,12

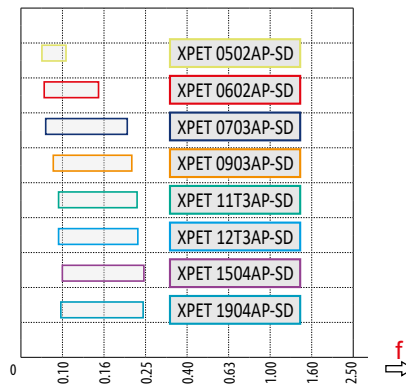

P	M	K	N	S	H
■	■	▣	■	▣	■
f → Voir diagramme					
XPETAP-SD					

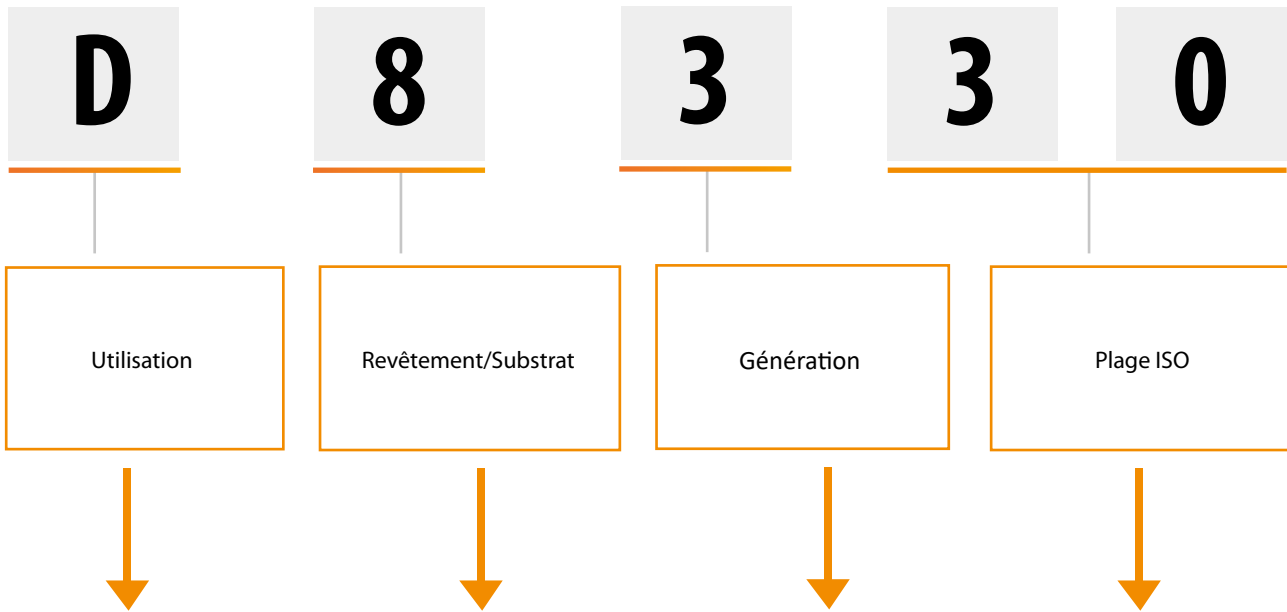

D	Perçage
M	Fraisage
T	Tournage
G	Tronçonnage et gorges

0 PVD 1 CVD	Application spéciale
2 PVD 3 CVD	Libre
4 PVD 5 CVD	Groupes K, H
6 PVD 7 CVD	Groupes M, S
8 PVD 9 CVD	Universel
B	CBN
C	Céramique
D	PCD
T	Cermet

1 - 9

01 - 50	
	01 - 05
	05 - 10
	10 - 20
	20 - 30
	30 - 40
	40 - 50



NUANCES POUR LE PERÇAGE

Identification de la nuance	Domaine d'application	Application	Avance	Vitesse de coupe	Résistance en conditions de travail compliquées	Revêtement	Couleur	Substrat	Bénéfice arrosage	Description de la nuance
D9335	P20 - P35	■				MT-CVD	■	FGM	+++	Cette nuance est recommandée pour les plaquettes périphériques des forets indexables ; elle convient parfaitement aux vitesses de coupe et aux avances les plus élevées.
	M15 - M30	■								
	K15 - K35	■								
	S10 - S20	☑								
D8330	P20 - P35	■				PVD	■	submicron H	+++	Il s'agit d'une nuance universelle pour les plaquettes périphériques des forets indexables ; elle peut être utilisée sur la plupart des matériaux et se distingue par sa grande fiabilité opérationnelle.
	M15 - M30	■								
	K15 - K35	■								
	S10 - S20	☑								
D8345	P30 - P50	■				PVD	■	submicron H	+++	Cette nuance est une nuance universelle pour la plaquette centrale des forets indexables ; elle est extrêmement résistante et convient à la plupart des matériaux.
	M20 - M40	■								
	K30 - K40	■								
	S20 - S30	☑								

Substrat

submicron H	Substrat à grains fins base WC-Co (< 1 µm)
FGM	Substrat gradient fonctionnel

Revêtement

MT-CVD	Méthode de revêtement par dépôt chimique à moyenne température
PVD	Méthode de revêtement par dépôt physique à basse température

Bénéfices de l'arrosage

+++	L'utilisation de l'arrosage est essentielle
-----	---



FORETS À PLAQUETTES – CONDITIONS DE COUPE RECOMMANDÉES

802D, 803D (XPET..AP, SCET..-UD)



	D9335	D8330	D8345	∅ 15	∅ 20	∅ 25	∅ 30	∅ 40	∅ 58
P1	■	■	■	0.07	0.08	0.09	0.10	0.12	0.16
P2	■	■	■	0.11	0.13	0.15	0.17	0.21	0.28
P3	■	■	■	0.13	0.15	0.18	0.20	0.24	0.32
P4	■	■	■	0.12	0.14	0.16	0.18	0.22	0.30
K1	■	■	■	0.14	0.16	0.19	0.21	0.26	0.34
K2	■	■	■	0.14	0.16	0.19	0.21	0.26	0.34
K3	■	■	■	0.14	0.16	0.19	0.21	0.26	0.34
K4	■	■	■	0.14	0.16	0.19	0.21	0.26	0.34
K5	■	■	■	0.14	0.16	0.19	0.21	0.26	0.34

802D, 803D (XPET..AP-SD, SCET..-SD)



	D9335	D8330	D8345	∅ 15	∅ 20	∅ 25	∅ 30	∅ 40	∅ 58
P1	■	■	■	0.08	0.09	0.10	0.11	0.14	0.18
P2	■	■	■	0.11	0.13	0.15	0.17	0.21	0.28
P3	■	■	■	0.13	0.15	0.18	0.20	0.24	0.32
P4	■	■	■	-	-	-	-	-	-
K1	▣	▣	▣	0.08	0.09	0.10	0.11	0.14	0.18
K2	▣	▣	▣	0.11	0.13	0.15	0.17	0.21	0.28
K3	▣	▣	▣	0.12	0.14	0.16	0.18	0.22	0.24
K4	▣	▣	▣	0.13	0.15	0.18	0.20	0.24	0.32
K5	▣	▣	▣	0.14	0.16	0.19	0.21	0.25	0.33
M1	■	■	■	0.12	0.14	0.16	0.18	0.22	0.30
M2	■	■	■	0.11	0.13	0.15	0.17	0.21	0.28
M3	■	■	■	0.07	0.08	0.09	0.10	0.12	0.16
M4	■	■	■	0.07	0.08	0.09	0.10	0.12	0.16
S1	▣	▣	▣	0.08	0.09	0.10	0.11	0.14	0.18
S2	▣	▣	▣	0.08	0.09	0.10	0.11	0.14	0.18
S3	▣	▣	▣	0.07	0.08	0.09	0.10	0.12	0.16
S4	▣	▣	▣	0.07	0.08	0.09	0.10	0.12	0.16

804D (XPET..AP, SCET..-UD)



	D9335	D8330	D8345	∅ 15	∅ 20	∅ 25	∅ 30	∅ 40	∅ 58
P1	■	■	■	0.06	0.07	0.08	0.09	0.10	0.14
P2	■	■	■	0.10	0.12	0.14	0.16	0.19	0.25
P3	■	■	■	0.12	0.14	0.16	0.18	0.22	0.30
P4	■	■	■	0.11	0.13	0.15	0.17	0.21	0.28
K1	■	■	■	0.13	0.15	0.18	0.20	0.24	0.32
K2	■	■	■	0.13	0.15	0.18	0.20	0.24	0.32
K3	■	■	■	0.13	0.15	0.18	0.20	0.24	0.32
K4	■	■	■	0.13	0.15	0.18	0.20	0.24	0.32
K5	■	■	■	0.13	0.15	0.18	0.20	0.24	0.32



FORETS À PLAQUETTES – CONDITIONS DE COUPE RECOMMANDÉES

804D (XPET..AP-SD, SCET..-SD)



	D9335	D8330	D8345	ø 15	ø 20	ø 25	ø 30	ø 40	ø 58
P1	■	■	■	0.07	0.08	0.09	0.10	0.12	0.16
P2	■	■	■	0.10	0.12	0.14	0.16	0.19	0.25
P3	■	■	■	0.12	0.14	0.16	0.18	0.22	0.30
P4	■	■	■	–	–	–	–	–	–
K1	☑	☑	☑	0.07	0.08	0.09	0.10	0.12	0.16
K2	☑	☑	☑	0.10	0.12	0.14	0.16	0.19	0.25
K3	☑	☑	☑	0.11	0.13	0.15	0.17	0.20	0.27
K4	☑	☑	☑	0.12	0.14	0.16	0.18	0.22	0.30
K5	☑	☑	☑	0.14	0.16	0.19	0.21	0.25	0.33
M1	■	■	■	0.11	0.13	0.15	0.17	0.21	0.28
M2	■	■	■	0.10	0.12	0.14	0.16	0.19	0.25
M3	■	■	■	0.06	0.07	0.08	0.09	0.10	0.14
M4	■	■	■	0.06	0.07	0.08	0.09	0.10	0.14
S1	☑	☑	☑	0.07	0.08	0.09	0.10	0.12	0.16
S2	☑	☑	☑	0.07	0.08	0.09	0.10	0.12	0.16
S3	☑	☑	☑	0.06	0.07	0.08	0.09	0.10	0.14
S4	☑	☑	☑	0.06	0.07	0.08	0.09	0.10	0.14

805D (XPET..AP, SCET..-UD)



	D9335	D8330	D8345	ø 15	ø 20	ø 25	ø 30	ø 40	ø 58
P1	■	■	■	0.06	0.07	0.08	0.09	0.10	0.14
P2	■	■	■	0.10	0.12	0.14	0.16	0.19	0.25
P3	■	■	■	0.12	0.14	0.16	0.18	0.22	0.30
P4	■	■	■	0.11	0.13	0.15	0.17	0.21	0.28
K1	■	■	■	0.13	0.15	0.18	0.20	0.24	0.32
K2	■	■	■	0.13	0.15	0.18	0.20	0.24	0.32
K3	■	■	■	0.13	0.15	0.18	0.20	0.24	0.32
K4	■	■	■	0.13	0.15	0.18	0.20	0.24	0.32
K5	■	■	■	0.13	0.15	0.18	0.20	0.24	0.32

805D (XPET..AP-SD, SCET..-SD)



	D9335	D8330	D8345	ø 15	ø 20	ø 25	ø 30	ø 40	ø 58
P1	■	■	■	0.07	0.08	0.09	0.10	0.12	0.16
P2	■	■	■	0.10	0.12	0.14	0.16	0.19	0.25
P3	■	■	■	0.12	0.14	0.16	0.18	0.22	0.30
P4	■	■	■	–	–	–	–	–	–
K1	☑	☑	☑	0.07	0.08	0.09	0.10	0.12	0.16
K2	☑	☑	☑	0.10	0.12	0.14	0.16	0.19	0.25
K3	☑	☑	☑	0.11	0.13	0.15	0.17	0.20	0.27
K4	☑	☑	☑	0.12	0.14	0.16	0.18	0.22	0.30
K5	☑	☑	☑	0.12	0.14	0.16	0.18	0.22	0.30
M1	■	■	■	0.11	0.13	0.15	0.17	0.21	0.28
M2	■	■	■	0.10	0.12	0.14	0.16	0.19	0.25
M3	■	■	■	0.06	0.07	0.08	0.09	0.10	0.14
M4	■	■	■	0.06	0.07	0.08	0.09	0.10	0.14
S1	☑	☑	☑	0.07	0.08	0.09	0.10	0.12	0.16
S2	☑	☑	☑	0.07	0.08	0.09	0.10	0.12	0.16
S3	☑	☑	☑	0.06	0.07	0.08	0.09	0.10	0.14
S4	☑	☑	☑	0.06	0.07	0.08	0.09	0.10	0.14



FORMULES DE CALCUL DES PARAMÈTRES DE COUPE

NOMENCLATURES ET FORMULES

Paramètre	Formule	Unité
Vitesse de rotation	$n = \frac{v_c \cdot 1000}{DC \cdot \pi}$	(tr/min)
Vitesse de coupe	$v_c = \frac{\pi \cdot DC \cdot n}{1000}$	(m/min)
Avance de table	$v_f = n \cdot f$	(mm/min)
Section transversale du trou	$A = \frac{\pi \cdot DC^2}{4}$	(mm ²)
Taux d'enlèvement de métal	$Q = \frac{v_f \cdot A}{1000}$	(cm ³ /min)
Durée d'usinage	$T_c = \frac{L + h}{v_f}$	(min/pièce)

DC Diamètre du foret

(mm)







h Distance entre la pointe du foret et la pièce à usiner avant l'avance (mm)

f Avance par tour

(mm/tr)

L Profondeur du trou (mm)

COUPLES DE SERRAGE RECOMMANDÉS POUR LES VIS

	 Nm					
US 2245-T07P	0.9	FLAG T07P	M 2.2	5.3	D-T7P	MR-0.8-2.0 vario
US 2205-T07P	0.9	FLAG T07P	M2.2	5.4	D-T7P	MR-0.8-2.0 vario
US 2506-T07P	1.2	FLAG T07P	M 2.5	6	D-T7P	MR-0.8-2.0 vario
US 2507-T08P	1.2	FLAG T08P	M 2.5	7	D-T8P	MR-0.8-2.0 vario
US 3007-T08P	2.0	FLAG T08P	M 3	7	D-T8P	MR-1.0-5.0 vario
US 3007-T09P	2.0	FLAG T09P	M 3	7.4	D-T9P	MR-1.0-5.0 vario
US 3009-T09P	2.0	FLAG T09P	M 3	8.7	D-T9P	MR-1.0-5.0 vario
US 3508-T15P	3.0	FLAG T15P	M 3.5	8.3	D-T15P	MR-1.0-5.0 vario
US 3510-T15P	3.0	FLAG T15P	M 3.5	10.6	D-T15P	MR-1.0-5.0 vario
US 4011-T15P	3.5	FLAG T15P	M 4	10.7	D-T15P	MR-1.0-5.0 vario
US 5012-T15P	5.0	FLAG T15P	M 5	12.2	D-T15P	MR-1.0-5.0 vario



CARACTÉRISTIQUES D'USINAGE POUR LES FORETS A PLAQUETTES

Ajustement radial

Ajustement du diamètre du trou et recommandations de réglage

Il est possible de régler radialement un foret à plaquettes afin d'obtenir un trou de diamètre plus petit ou plus grand que le diamètre de foret. Les valeurs d'ajustement radial sont présentées dans le tableau des caractéristiques générales des forets.

Outil rotatif

Un support ajustable est recommandé pour le réglage du diamètre d'un trou d'une précision IT10 ou plus avec les forets rotatifs de la série 80xD.

Outil fixe

Lors du montage du foret, s'assurer que le centre du foret et le centre de la pièce à usiner sont alignés. Pour un diamètre de trou plus important, déplacer le foret afin que la plaquette périphérique parte de l'axe central de la pièce.

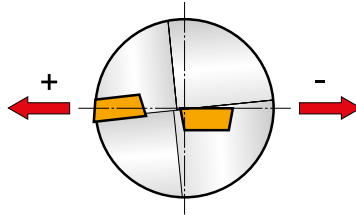

Duree de vie d'outil

Les plaquettes ne doivent pas être utilisées lorsque l'usure en dépouille excède $0,2 \div 0,4$ mm au point le plus important.

Les recommandations de vitesse de coupe mentionnées dans ce catalogue sont basées sur une durée de vie de plaquette périphérique représentant une longueur totale de trou percé de 7 m (durabilité $20 \div 30$ min.)

EP

DOUILLE DE RÉGLAGE

Diam. de queue	Diam. de foret	Plage
25	15 – 24	+0.4 – -0.2
32	24.5 – 40	+0.4 – -0.2

Ajustement de diamètre pour centre d'usinage

Plage d'ajustement de diamètre

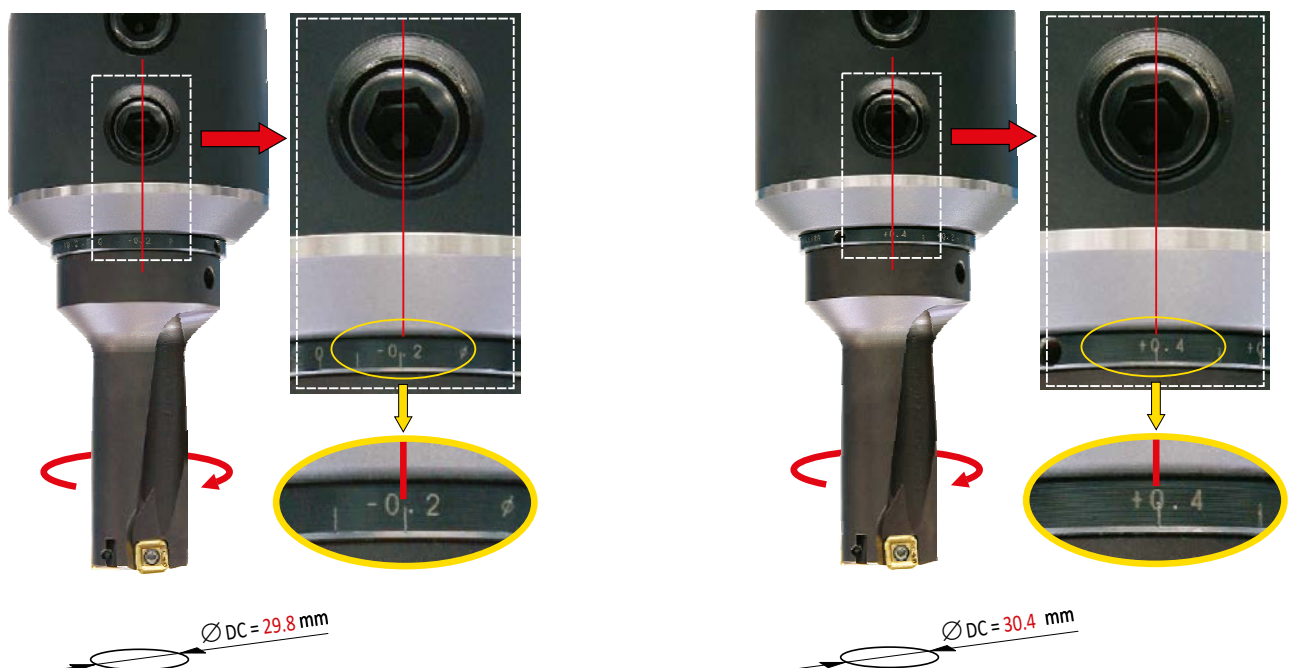



EP

RÉGLAGE DES FORETS À PLAQUETTES

Diam. de queue	Diam. de foret	Plage
25	15 – 24	+0.2 – -0.15
32	24.5 – 40	+0.2 – -0.15

Ajustement de hauteur/centrage
– pour les opérations de tournage

Plage d'ajustement de hauteur et de centrage

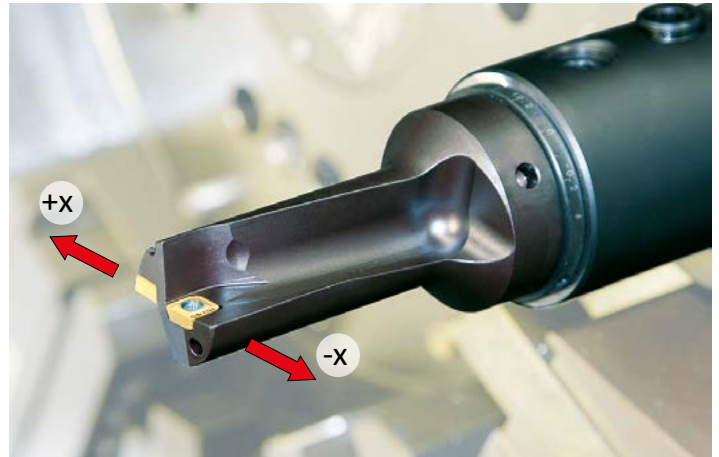

CARACTÉRISTIQUES D'USINAGE POUR LES FORETS À PLAQUETTES

Pression recommandée du liquide de coupe

Diamètre de foret DC (mm)	Pression du liquide de coupe	
	Longueur de foret	
	2.0 – 2.5 DC	3.0 – 5.0 DC
15 – 25	6 bar	12 bar
26 – 40	4.5 bar	9 bar
> 40	3 bar	6 bar

Débit de liquide de refroidissement nécessaire

PERÇAGE À SEC

Il est possible de percer sans liquide de refroidissement dans la fonte et l'acier, à condition d'utiliser de l'air comprimé à travers le foret.

Puissance nette requise

■ $f \Rightarrow = 0.18$
 ■ $f \Rightarrow = 0.12$
 ■ $f \Rightarrow = 0.08$

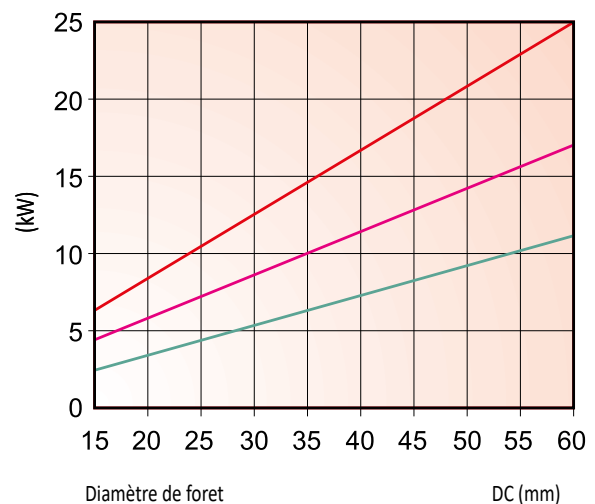
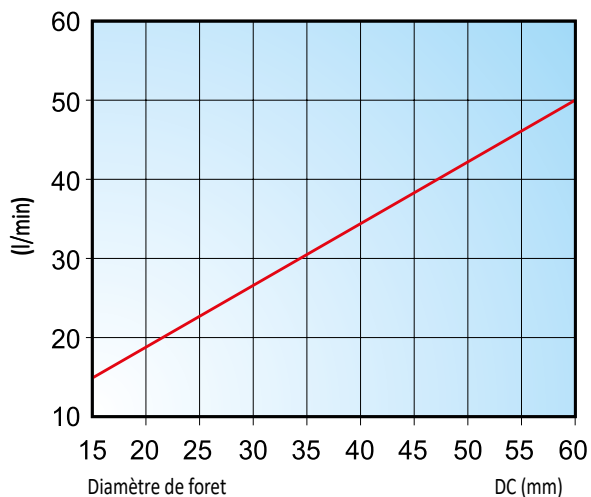

	<p>PERÇAGE D'UN TROU BORGNE L'arrosage est nécessaire pour un trou plus profond que 1xD</p>
	<p>PERÇAGE D'UN TROU DÉBOUCHANT Une rondelle peut être produite lors de la sortie du foret hors de la pièce. Pour la sécurité de l'opérateur, il est essentiel d'équiper la machine de dispositifs de protection.</p>
	<p>PERÇAGE EXCENTRÉ Diminuer l'avance jusqu'au plus bas de celle recommandée pour les plaquettes sélectionnées. Voir les pages géométries de plaquettes. Ne pas dépasser les valeurs de réglage radial.</p>
	<p>ALÉSAGE SUR DES SURFACES IRREGULIÈRES ET MOULÉES Diminuer l'avance à la pénétration des forets à plaquettes indexables, jusqu'à ce que les deux plaquettes soient engagées.</p>
	<p>ALÉSAGE ET PERÇAGE DANS UN TROU PRÉ-PERÇÉ Si le trou pré-perçé est supérieur à 1/4 du diamètre de foret, diminuer l'avance.</p>
	<p>PERÇAGE A TRAVERS UN TROU EXISTANT Diminuer l'avance de 50% lors d'un perçage à travers un trou existant. Le diamètre du trou existant ne doit pas dépasser 0,25xD .</p>
	<p>COUPE INTERROMPUE ET TRÉFLAGE Diminuer l'avance jusqu'au plus bas de celle recommandée pour les plaquettes sélectionnées. Voir les pages géométries de plaquettes.</p>
	<p>PERÇAGE SUR SURFACE INCURVÉE Le perçage centré peut être effectué avec une avance réduite à 50% en entrée et en sortie.</p>
	<p>PERÇAGE SUR DES SURFACES INCLINÉES Diminuer l'avance de 50% à la pénétration des forets à plaquettes indexées, jusqu'à ce que les deux plaquettes soient engagées si l'angle d'entrée est supérieur à 5°.</p>
	<p>SORTIE DE SURFACE INCLINÉE Diminuer l'avance de 50%, si l'angle de sortie est supérieur à 5°.</p>
	<p>AMORÇAGE SUR UN POINT DE SOUDURE Un dressage est recommandé avant le perçage. Diminuer l'avance de 50% pendant le perçage du matériau soudé.</p>
	<p>PERÇAGE DE MATÉRIAUX EMPILÉS Éviter des écarts de plus de 0,2 mm entre couches. La pièce doit être fermement fixée. Il est nécessaire de réduire l'avance.</p>



RÉSOLUTION DES PROBLÈMES

MANQUE DE PUISSANCE DE LA BROCHE	<ul style="list-style-type: none">a) réduire la vitesse de coupe = réduire la vitesse de rotation de la brocheb) réduire l'avance
USURE EXCESSIVE DE L'ARÊTE DE LA PLAQUETTE DE COUPE PÉRIPHÉRIQUE	<ul style="list-style-type: none">a) réduire la vitesse de coupe = réduire la vitesse de rotation de la brocheb) choisir une nuance de plaquette plus résistante à l'usurec) augmenter le débit et la pression du liquide de coupe
ÉCAILLAGE DE LA PLAQUETTE PÉRIPHÉRIQUE	<ul style="list-style-type: none">a) réduire l'avance jusqu'à l'engagement complet de la plaquette périphériqueb) choisir une nuance de plaquette plus tenacec) réduire la vitesse de coupe
ÉCAILLAGE DE LA PLAQUETTE CENTRALE	<ul style="list-style-type: none">a) réduire l'avance à l'entréeb) vérifier le serrage du foret et de la pièce à usiner
COPEAU CONTINU MAL FORMÉ	<ul style="list-style-type: none">a) ajuster l'avanceb) augmenter la vitesse de coupe tout en réduisant l'avance.
ACCUMULATION DE COPEAUX COURTS DANS LES GOUJURES	<ul style="list-style-type: none">a) augmenter le débit et la pression du liquide de coupeb) réduire la vitesse de coupec) ajuster l'avance



TAILLES DE FORETS RECOMMANDÉES POUR LE TARAUDAGE

Filets métriques ISO		Diamètre de foret recommandé pour	
Filet	Pas	Taraud de coupe	Taraud par déformation
M16 × 1.0	1.00	15.0	15.5
M16 × 0.75	0.75	15.3	–
M17 × 1.0	1.00	16.0	–
M18	2.50	15.5	16.8
M18 × 2.0	2.00	16.0	–
M18 × 1.5	1.50	16.5	17.3
M18 × 1.0	1.00	17.0	–
M20	2.50	17.5	18.8
M20 × 2.0	2.00	18.0	–
M20 × 1.5	1.50	18.5	19.3
M20 × 1.0	1.00	19.0	–
M22	2.50	19.5	20.8
M22 × 2.0	2.00	20.0	–
M22 × 1.5	1.50	20.5	21.3
M22 × 1.0	1.00	21.0	–
M24	3.00	21.0	22.5
M24 × 2.0	2.00	22.0	–
M24 × 1.5	1.50	22.5	23.3
M27	3.00	24.0	–
M27 × 2.0	2.00	25.0	–
M30	3.50	26.5	–
M30 × 2.0	2.00	28.0	–
M33	3.50	29.5	–
M36	4.00	32.0	–
M36 × 3.0	3.00	33.0	–
M39	4.00	35.0	–
M42	4.50	37.5	–
M42 × 3.0	3.00	39.0	–
M45	4.50	40.5	–
M48	5.00	43.0	–
M48 × 3.0	3.00	45.0	–
M52	5.00	47.0	–
M52 × 3.0	3.00	48.0	–

Filets en pouce UNF		Diamètre de foret recommandé pour	
Filet	Pas	Taraud de coupe	Taraud par déformation
3/4"	10	16.7	17.8
7/8"	9	19.5	20.8
1"	8	22.2	23.8
1 1/8"	7	25.0	–
1 1/4"	7	28.2	–
1 3/8"	6	31.0	–
1 1/2"	6	34.0	–
1 3/4"	5	39.5	–
2"	4 1/2	45.2	–
2 1/4"	4 1/2	51.6	–
2 1/2"	4	57.2	–

Filets Whitworth		Diamètre de foret recommandé pour	
Filet	Pas	Taraud de coupe	Taraud par déformation
G 3/8"	19	15.3	16.0
G 1/2"	14	19.0	20.0
G 5/8"	14	21.0	22.0
G 3/4"	14	24.5	25.5
G 7/8"	14	28.3	29.3
G 1"	11	30.8	32.0
G 1 1/8"	11	35.5	–
G 1 1/4"	11	39.5	–
G 1 3/8"	11	41.8	–
G 1 1/2"	11	45.3	–
G 1 3/4"	11	51.0	–
G 2"	11	57.0	–

Filet unifié (pouces) UNF		Diamètre de foret recommandé pour	
Filet	Pas	Taraud de coupe	Taraud par déformation
3/4"	16	17.5	18.3
7/8"	14	20.5	21.3
1"	12	23.4	24.3
1 1/8"	12	26.5	–
1 1/4"	12	29.8	–
1 3/8"	12	33.0	–
1 1/2"	12	36.0	–



SYSTÈMES
D'ALÉSAGE





PERÇAGE ET ALÉSAGE – CONTENU GÉNÉRAL

6		WMG ET ISO 13399
12	FORETS MONOBLOCS	INSTRUCTIONS
15		FORETS CARBURE
66		FORETS HSS
176		FLUIDES DE COUPE
186		INFORMATIONS TECHNIQUES
190		ALÉSOIRS ET FRAISES À CHANFREINER
264	FORETS INDEXABLES	INSTRUCTIONS
271		FORETS HYDRA À TÊTE INTERCHANGEABLE
297		INFORMATIONS TECHNIQUES
307		FORETS À PLAQUETTES INDEXABLES
327		INFORMATIONS TECHNIQUES
350	SYSTÈMES D'ALÉSAGE	INSTRUCTIONS
359		TÊTES À ALÉSER
376		ACCESSOIRES D'ALÉSAGE
381		PLAQUETTES
404		ATTACHEMENTS
418		KITS D'ALÉSAGE
429		INFORMATIONS TECHNIQUES



PLAQUETTES – PAGE DE PRÉSENTATION



1 CCGT

	IC (mm)	D1 (mm)	L (mm)	S (mm)
0602	6.350	2.80	6.40	2.38
0602-SF3	6.350	2.80	6.40	2.58
0803-AL	7.940	3.40	8.10	3.43
0803-SF3	7.940	3.40	8.10	3.43
09T3	9.525	4.40	9.70	3.97
09T3-SF3	9.525	4.40	9.70	4.22
1204	12.700	5.50	12.90	4.76
1204-SF3	12.700	5.50	12.90	5.01

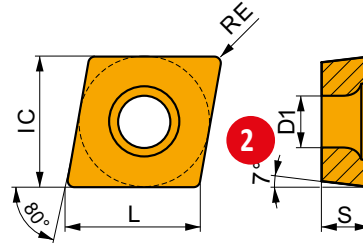

Adéquation et valeurs de départ pour la vitesse de coupe (vc), l'avance (f) et la profondeur de coupe (ap). Reportez-vous à notre application "Calculators" pour d'autres calculs.

Product	RE (mm)	P			M			K			N			S			H		
		vc [m/min]	f [mm/rev]	ap [mm]	vc [m/min]	f [mm/rev]	ap [mm]	vc [m/min]	f [mm/rev]	ap [mm]	vc [m/min]	f [mm/rev]	ap [mm]	vc [m/min]	f [mm/rev]	ap [mm]			

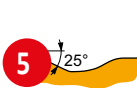

10 Géométrie AL avec une coupe très positive pour l'usage de la finition fine à l'ébauche et pour les coupes continues à légèrement interrompues.

CCGT 060202F-AL	HF7	0.2	-	-	-	-	-	-	-	360	0.12	1.0	-	-	-	-	-	-
CCGT 060204F-AL	T0315	0.4	-	-	-	-	-	-	-	300	0.24	1.0	-	-	-	-	-	-
CCGT 080302F-AL	T0315	0.2	-	-	-	-	-	-	-	360	0.12	1.0	-	-	-	-	-	-
CCGT 080304F-AL	HF7	0.4	-	-	-	-	-	-	-	300	0.24	1.0	-	-	-	-	-	-
	T0315	0.4	-	-	-	-	-	-	-	300	0.24	1.0	-	-	-	-	-	-
CCGT 09T302F-AL	HF7	0.2	-	-	-	-	-	-	-	360	0.12	1.0	-	-	-	-	-	-
	T0315	0.2	-	-	-	-	-	-	-	360	0.12	1.0	-	-	-	-	-	-
CCGT 09T304F-AL	HF7	0.4	-	-	-	-	-	-	-	300	0.24	1.5	-	-	-	-	-	-
	T0315	0.4	-	-	-	-	-	-	-	300	0.24	1.5	-	-	-	-	-	-
CCGT 09T308F-AL	HF7	0.8	-	-	-	-	-	-	-	200	0.48	1.5	-	-	-	-	-	-
	T0315	0.8	-	-	-	-	-	-	-	200	0.48	1.5	-	-	-	-	-	-
CCGT 120404F-AL	HF7	0.4	-	-	-	-	-	-	-	300	0.24	2.4	-	-	-	-	-	-
	T0315	0.4	-	-	-	-	-	-	-	300	0.24	2.4	-	-	-	-	-	-
CCGT 120408F-AL	HF7	0.8	-	-	-	-	-	-	-	200	0.48	2.4	-	-	-	-	-	-
	T0315	0.8	-	-	-	-	-	-	-	200	0.48	2.4	-	-	-	-	-	-

CCGT120404F-AL:T0315

Mentionner le code complet de la spécification pour toute commande.

Nuance

Deux points

Code de plaquette
ISO



PLAQUETTES – PAGE DE PRÉSENTATION

Élém.	Description	Élém.	Description
1	Désignation de la plaquette	7	Code de plaquette ISO
2	Schéma de la plaquette	8	Nuance
3	Tableau des tailles de plaquette (mm)	9	Rayons de plaquette (mm)
4	Illustration de la plaquette	10	Description de la géométrie
5	Profil de l'arête de coupe principale	11	Conditions de coupe par groupe de matériaux
6	Icônes – caractéristiques spécifiques et type d'arête de coupe		

1 D75-BB

P M K N S H **2**

PRAMET **3 S(P)**



Tête d'alésage d'ébauche 75°, gros diamètres d'alésage - Ø220 à Ø500 mm

Grande tête d'alésage haute performance à 75° pour l'ébauche. Convient pour l'alésage et le chanfreinage de trous débouchants, borgnes et sécants. Disponible avec plaquettes de type CC .., TC .. ou CN .. et pour une plage de diamètres de trous de Ø220 à Ø500 mm dans des tailles d'accouplements de 300 à 500 mm. Haute précision et répétabilité.

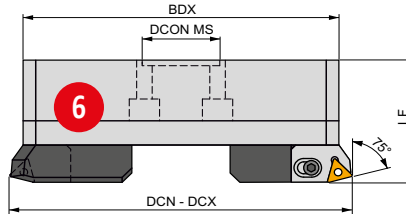

Icons for tool features and applications, including a 75° angle icon, a 2x magnification icon, and various tool configurations.

Product	CZC MS	DCN	DCX	BDX	DCON MS	LF	Icon 1	Icon 2	Icon 3	Icon 4	Icon 5	Icon 6	Icon 7	Icon 8	Icon 9	Icon 10
	(mm)	(mm)	(mm)	(mm)	(mm)	(mm)										
D 30075 300	300	220.00	320.00	202	60.00	90.00	3CT 75 300	US 0625	HXK 5	TC.. 16T3..	US 0415-T15P	SDR T15P	HXK 5	HXK 4	9.40	
D 30075 402	300	220.00	320.00	202	60.00	90.00	3CT 75 402	US 0625	HXK 5	CC.. 1204..	US 0513-T20P	SDR T20P	HXK 5	HXK 4	9.37	
D 30075 402N	300	220.00	320.00	202	60.00	90.00	3CT 75 402 N	US 0625	HXK 5	CN.. 1204..	US 0613-H25	HXK 2.5	HXK 5	HXK 4	9.37	
D 40075 300	400	290.00	400.00	272	60.00	90.00	3CT 75 300	US 0625	HXK 5	TC.. 16T3..	US 0415-T15P	SDR T15P	HXK 5	HXK 4	9.40	
D 40075 402	400	290.00	400.00	272	60.00	90.00	3CT 75 402	US 0625	HXK 5	CC.. 1204..	US 0513-T20P	SDR T20P	HXK 5	HXK 4	9.37	
D 40075 402N	400	290.00	400.00	272	60.00	90.00	3CT 75 402 N	US 0625	HXK 5	CN.. 1204..	US 0613-H25	HXK 2.5	HXK 5	HXK 4	9.37	

1 69871-BS

PRAMET



Attachement avec accouplement DIN 69871 pour têtes d'alésage

Attachement très rigide DIN 69871 (pour ATC) pour têtes d'alésage, disponible avec arrosage centralisé et avec cônes 30, 40 et 50. Différentes longueurs d'arbre disponibles. Les tailles d'accouplement de 22 à 160 mm peuvent être utilisées avec les extensions EXT-BS, les réducteurs RED-BS et les adaptateurs agrandisseurs LA-BS. Pour les applications nécessitant une précision et une répétabilité élevées.

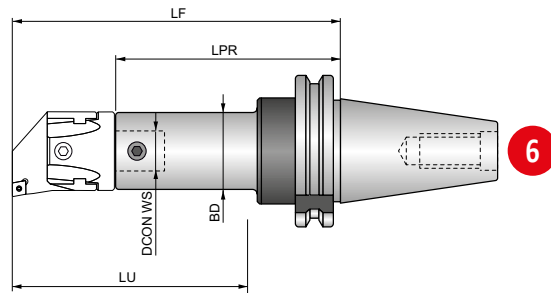

Product	Icon 1	CZC MS	BD	DCON WS	LF	LPR	LU	Icon 2	Icon 3	Icon 4
		(mm)	(mm)	(mm)	(mm)	(mm)	(mm)			(kg)
AS 330 022 100 R		30	22	22.00	12.00	138.00	104	✓	US 0608	0.72
AS 330 027 055 R		30	27	27.00	15.00	90.00	48	✓	US 0609	0.56
AS 330 027 100 R		30	27	27.00	15.00	138.00	96	✓	US 0609	0.68
AS 330 060 R		30	32.00	20.00	51	60.00		✓	US 0608	
AS 330 100 R		30	32.00	20.00	93	100.00		✓	US 0608	
AS 340 022 080 R		40	22	22.00	12.00	118.00	84	✓	US 0608	1.14



TÊTES À ALÉSER ET ATTACHEMENTS – VUE D'ENSEMBLE

Élém.	Désignation	Élém.	Désignation
1	Désignation de la tête à aléser/attachement	13	Cartouche
2	Groupes de matériaux pour lesquels l'outil est indiqué	14	Vis de cartouche
3	Système de fixation de la plaquette	15	Clé pour vis de cartouche
4	Image pour illustration	16	Groupe de plaquettes compatibles
5	Description de l'outil	17	Vis de plaquette
6	Schéma de l'outil	18	Clé pour vis de plaquette
7	Qualité de surface réalisable	19	Clé de réglage pour la tête
8	Caractéristiques du produit	20	Clé de serrage pour la tête
9	Applications du produit	21	Poids (kg)
10	Code outil ¹⁾	22	Alimentation interne de liquide de refroidissement
11	Code de la taille de tête/attachement ²⁾	23	Vis de fixation de la tête
12	Dimensions de l'outil (mm)	24	Taille d'attachement ³⁾

¹⁾ La désignation du code outil est présentée dans la partie technique.

²⁾ La tête d'alésage et son attachement doivent avoir le même code de taille pour que leur compatibilité soit garantie.

³⁾ Voir le dessin schématique pour le type d'attachement.



DORMER PRAMET



TOUS LES MATÉRIAUX

Acier, acier inoxydable, fonte, superalliages ou matériaux non-ferreux, notre application Calculateur d'usinage couvre tous les matériaux d'usinage. Téléchargez-la dès maintenant depuis votre magasin d'applis. **Simply Reliable.**

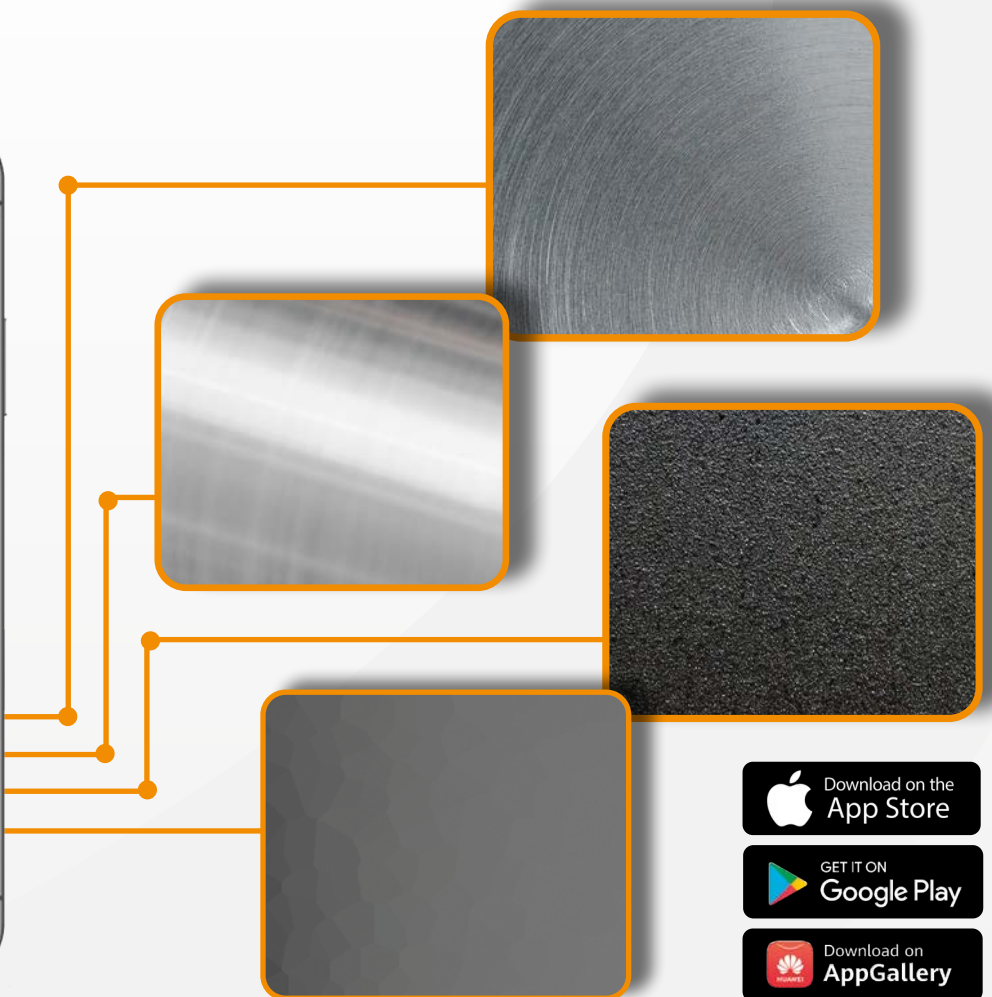
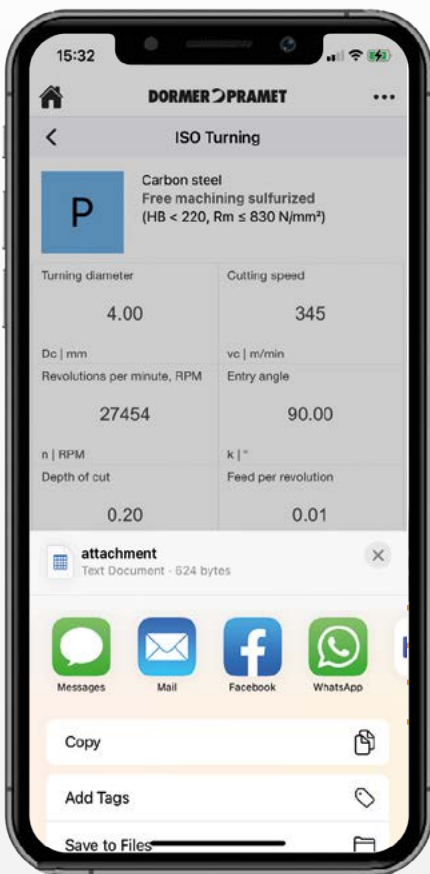



SYSTÈMES D'ALÉSAGE – PRÉSENTATION DES ICÔNES

ICÔNES GÉNÉRALES

	Utilisation principale		Finition – bonne qualité de surface		Ébauche – rugosité de surface sans limite
	Utilisation possible		Usinage moyen – bonne qualité de surface		

CARACTÉRISTIQUES GÉNÉRALES

	1 dent par tour		Diamètre de l'outil ajustable
	2 dents par tour		

OPÉRATIONS DE PERÇAGE

	Alésage de trous borgnes		Alésage sur épaulement		Chanfreinage (biseautage) dans un trou
	Alésage sur trous sécants		Chanfreinage (biseautage)		Alésage de trous débouchants

CARACTÉRISTIQUES

	Premier choix		Vitesse de coupe élevée		Arête avec facette
	Pour matières à copeaux courts		Long porte-à-faux		Arête ronde
	Pour matériaux tenaces (copeaux longs)		Pièces fines / parois fines		Arête ronde avec double facette
	Usinage lourd		Gamme d'options universelles		Arête ronde avec facette
					Arête vive

AUTRE





	Taille conicité
--	-----------------

PARTIE TECHNIQUE

	Avance (mm/tour)		Vitesse de coupe moyenne, rigidité du système limitée (coupe légèrement interrompue)
	Vitesse de coupe très élevée, excellente rigidité du système (conditions de travail stables)		Vitesse de coupe faible, mauvaise rigidité du système (coupe interrompue)
	Vitesse de coupe élevée, bonne rigidité du système (conditions de travail stables)		Vitesse de coupe très faible, très mauvaise rigidité du système (conditions de travail très instables)
	Vitesse de coupe élevée, rigidité du système légèrement limitée (variation de la profondeur de coupe)		



SYSTÈMES D'ALÉSAGE



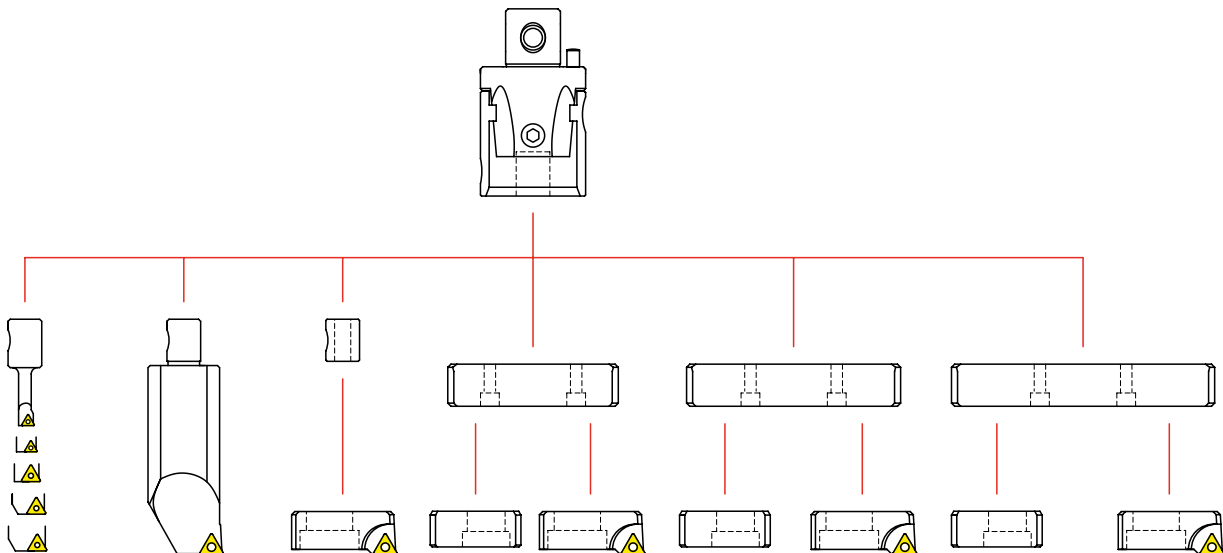

	TÊTES D'ÉBAUCHE		
			
Description	D75 / D90	D75-C/D90-C	D75-BB/D90-BB
Diamètre d'alésage	24 – 82	80 – 220	220 – 500
Tolérance de trou	IT9	IT9	IT9
Profondeur d'alésage max.	5×D	4×D	360 mm
Angle d'attaque	75° / 90°	75° / 90°	75° / 90°
Précision d'ajustement (mm/Ø)	–	–	–
	361, 364	362, 365	363, 366

KITS D'ALÉSAGE – 420 – 427







SYSTÈMES D'ALÉSAGE

TÊTES DE FINITION			TÊTES DE MICRO-ALÉSAGE	
				
F75/F90	F75-C/F90-C	F75-BB/F90-BB	MB-H	
24 – 82	80 – 220	220 – 500	8 – 38	
IT7	IT7	IT7	IT6	
5×D	4×D	–	104 mm	
75° / 90°	75° / 90°	75° / 90°	–	
0.002	0.002	0.002	0.002	
367, 370	368, 371	369, 372	373	

BARRES D'ALÉSAGE, ACCESSOIRES ET PLAQUETTES

ISO BARS	ISO BARS A042	CHAM-BS	CART-BS	PLAQUETTES
				
 374	 375	 380	 378	 388



SYSTEMES D'ALÉSAGE

ATTACHEMENTS

69871-BS ISO 30, 40, 50	BT-BS ISO 30, 40, 50	HSK-BS 50A, 63A, 100A	2080-BS ISO 40, 50	MOR-BS MORSE	WEL-BS WELDON
406	408	410	411	413	414
					

ACCESSOIRES

EXT-BS	RED-BS	LA-BS
415	416	417
		

KITS D'ALÉSAGE – 420 – 427





TÊTES A ALÉSER



DÉSIGNATION DE LA TÊTE À ALÉSER

1	2	3	4
D	042	75	402N

1		2	3	4	
Type d'outil		Taille	Angle d'attaque	Code du logement de plaquette	
D	Ébauche	022	75	300	TC..16T3.
		027	90	400	CC..0602..
		032		401	CC..0803..
		042		402	CC..1204..
A	Finition	054		409	CC..09T3..
		068		402N	CN..1204..
		085			
		100			
		200			
		300			
		400			
		500			



D75



PRAMET

S(P)



Tête d'alésage d'ébauche 75°, petits diamètres d'alésage - Ø24 à Ø82 mm

Petite tête d'alésage haute performance à 75° pour l'ébauche. Convient pour l'alésage et le chanfreinage de trous débouchants, borgnes et sécants. Disponible avec plaquettes de type CC .., TC .. ou CN .. et pour une plage de diamètres de trou de Ø24 à Ø82 mm dans des tailles d'accouplement de 22 à 54 mm. Haute précision et répétabilité.

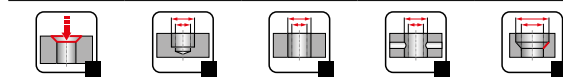
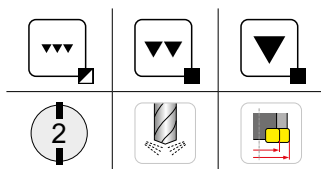
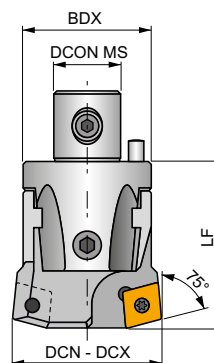

Produit	CZC MS	DCN	DCX	BDX	DCON MS	LF						
D 02275 400	22	24.00	30.00	22	12.00	34.00	CC.. 0602..	US 0206-T08P	SDR T08P	HXX 2	HXX 3	0.10
D 02775 401	27	29.00	40.00	27	15.00	42.00	CC.. 0803..	US 0307-T10P	SDR T10P	HXX 2	HXX 4	0.17
D 02775 409	27	29.00	40.00	27	15.00	42.00	CC.. 09T3..	US 0408-T15P	SDR T15P	HXX 2	HXX 4	0.17
D 03275 401	32	39.00	50.00	32	20.00	45.00	CC.. 0803..	US 0307-T10P	SDR T10P	HXX 2.5	HXX 4	0.27
D 03275 409	32	39.00	50.00	32	20.00	45.00	CC.. 09T3..	US 0408-T15P	SDR T15P	HXX 2.5	HXX 4	0.27
D 04275 300	42	49.00	65.00	42	24.00	56.00	TC.. 16T3..	US 0415-T15P	SDR T15P	HXX 3	HXX 5	0.54
D 04275 402	42	49.00	65.00	42	24.00	56.00	CC.. 1204..	US 0513-T20P	SDR T20P	HXX 3	HXX 5	0.54
D 04275 402N	42	53.00	65.00	42	24.00	56.00	CN.. 1204..	US 0613-H25	HXX 2.5	HXX 3	HXX 5	0.53
D 05475 300	54	63.00	82.00	54	28.00	66.00	TC.. 16T3..	US 0415-T15P	SDR T15P	HXX 3	HXX 6	1.07
D 05475 402	54	63.00	82.00	54	28.00	66.00	CC.. 1204..	US 0513-T20P	SDR T20P	HXX 3	HXX 6	1.07
D 05475 402N	54	63.00	82.00	54	28.00	66.00	CN.. 1204..	US 0613-H25	HXX 2.5	HXX 3	HXX 6	1.03



D75-C

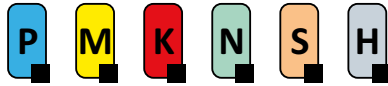

PRAMET

S(P)



Tête d'alésage d'ébauche 75°, diamètres d'alésage moyens - Ø80 à Ø220 mm

Tête d'alésage haute performance à 75° de taille moyenne pour l'ébauche. Convient pour l'alésage et le chanfreinage de trous débouchants, borgnes et sécants. Disponible avec plaquettes de type CC .., TC .. ou CN .. et pour une plage de diamètres de trous de Ø80 à Ø220 mm dans des tailles d'accouplements de 68 à 200 mm. Haute précision et répétabilité.

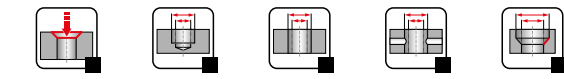
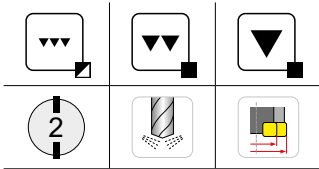
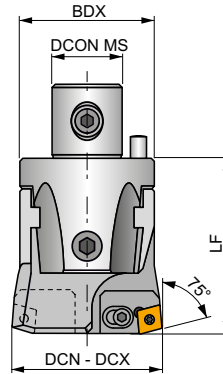

Produit	CZC MS	DCN	DCX	BDX	DCON MS	LF										kg
		(mm)	(mm)	(mm)	(mm)	(mm)										
D 06875 300	68	80.00	102.00	68	36.00	86.00	2CT 75 300	US 0616	HXK 5	TC.. 16T3..	US 0408-T15P	SDRT15P	HXK 4	HXK 8	2.16	
D 06875 402	68	80.00	102.00	68	36.00	86.00	2CT 75 402	US 0616	HXK 5	CC.. 1204..	US 0509-T20P	SDRT20P	HXK 4	HXK 8	2.15	
D 06875 402N	68	80.00	102.00	68	36.00	86.00	2CT 75 402 N	US 0616	HXK 5	CN.. 1204..	US 0613-H25	HXK 2.5	HXK 4	HXK 8	2.21	
D 08575 300	85	100.00	125.00	85	50.00	100.00	3CT 75 300	US 0625	HXK 5	TC.. 16T3..	US 0415-T15P	SDRT15P	HXK 5	HXK 8	4.16	
D 08575 402	85	100.00	125.00	85	50.00	100.00	3CT 75 402	US 0625	HXK 5	CC.. 1204..	US 0513-T20P	SDRT20P	HXK 5	HXK 8	4.13	
D 08575 402N	85	100.00	125.00	85	50.00	100.00	3CT 75 402 N	US 0625	HXK 5	CN.. 1204..	US 0613-H25	HXK 2.5	HXK 5	HXK 8	4.23	
D 10075 300	100	125.00	160.00	110	60.00	100.00	3CT 75 300	US 0625	HXK 5	TC.. 16T3..	US 0415-T15P	SDRT15P	HXK 5	HXK 8	6.57	
D 10075 402	100	125.00	160.00	110	60.00	100.00	3CT 75 402	US 0625	HXK 5	CC.. 1204..	US 0513-T20P	SDRT20P	HXK 5	HXK 8	6.55	
D 10075 402N	100	125.00	160.00	110	60.00	100.00	3CT 75 402 N	US 0625	HXK 5	CN.. 1204..	US 0613-H25	HXK 2.5	HXK 5	HXK 8	6.57	
D 20075 300	200	160.00	220.00	145	60.00	100.00	3CT 75 300	US 0625	HXK 5	TC.. 16T3..	US 0415-T15P	SDRT15P	HXK 5	HXK 8	8.87	
D 20075 402	200	160.00	220.00	145	60.00	100.00	3CT 75 402	US 0625	HXK 5	CC.. 1204..	US 0513-T20P	SDRT20P	HXK 5	HXK 8	8.88	
D 20075 402N	200	160.00	220.00	145	60.00	100.00	3CT 75 402 N	US 0625	HXK 5	CN.. 1204..	US 0613-H25	HXK 2.5	HXK 5	HXK 8	8.95	



D75-BB

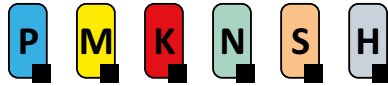

PRAMET

S(P)



Tête d'alésage d'ébauche 75°, gros diamètres d'alésage - Ø220 à Ø500 mm

Grande tête d'alésage haute performance à 75° pour l'ébauche. Convient pour l'alésage et le chanfreinage de trous débouchants, borgnes et sécants. Disponible avec plaquettes de type CC .., TC .. ou CN .. et pour une plage de diamètres de trous de Ø220 à Ø500 mm dans des tailles d'accouplements de 300 à 500 mm. Haute précision et répétabilité.

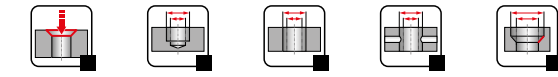
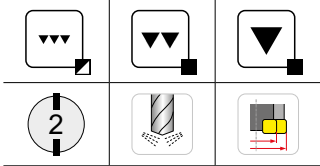
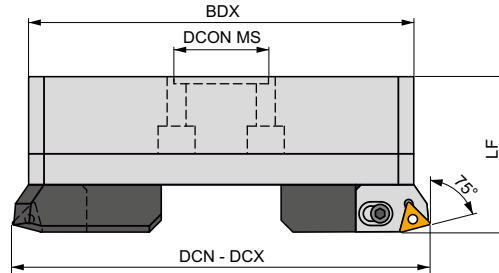

Produit	CZC MS	DCN	DCX	BDX	DCON MS	LF									kg
		(mm)	(mm)	(mm)	(mm)	(mm)									
D 30075 300	300	220.00	320.00	202	60.00	90.00	3CT 75 300	US 0625	HXK 5	TC.. 16T3..	US 0415-T15P	SDR T15P	HXK 5	HXK 4	9.40
D 30075 402	300	220.00	320.00	202	60.00	90.00	3CT 75 402	US 0625	HXK 5	CC.. 1204..	US 0513-T20P	SDR T20P	HXK 5	HXK 4	9.37
D 30075 402N	300	220.00	320.00	202	60.00	90.00	3CT 75 402 N	US 0625	HXK 5	CN.. 1204..	US 0613-H25	HXK 2.5	HXK 5	HXK 4	9.37
D 40075 300	400	290.00	400.00	272	60.00	90.00	3CT 75 300	US 0625	HXK 5	TC.. 16T3..	US 0415-T15P	SDR T15P	HXK 5	HXK 4	12.92
D 40075 402	400	290.00	400.00	272	60.00	90.00	3CT 75 402	US 0625	HXK 5	CC.. 1204..	US 0513-T20P	SDR T20P	HXK 5	HXK 4	12.95
D 40075 402N	400	290.00	400.00	272	60.00	90.00	3CT 75 402 N	US 0625	HXK 5	CN.. 1204..	US 0613-H25	HXK 2.5	HXK 5	HXK 4	12.98
D 50075 300	500	370.00	500.00	352	60.00	90.00	3CT 75 300	US 0625	HXK 5	TC.. 16T3..	US 0415-T15P	SDR T15P	HXK 5	HXK 4	16.74
D 50075 402	500	370.00	500.00	352	60.00	90.00	3CT 75 402	US 0625	HXK 5	CC.. 1204..	US 0513-T20P	SDR T20P	HXK 5	HXK 4	16.74
D 50075 402N	500	370.00	500.00	352	60.00	90.00	3CT 75 402 N	US 0625	HXK 5	CN.. 1204..	US 0613-H25	HXK 2.5	HXK 5	HXK 4	16.74



D90

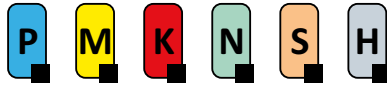

PRAMET

S(P)



Tête d'alésage d'ébauche 90°, petits diamètres d'alésage - Ø24 à Ø82 mm

Petite tête d'alésage haute performance à 90° pour l'ébauche. Convient pour les trous débouchants, borgnes et sécants. Disponible avec plaquettes de type CC .., TC .., CN .. et pour une plage de diamètres de trou de Ø24 à Ø82 mm dans des tailles d'accouplement de 22 à 54 mm. Haute précision et répétabilité.

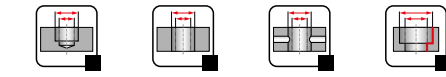
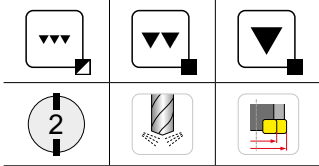
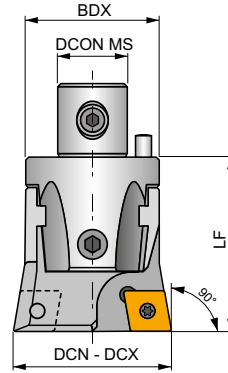

Produit	CZC MS	DCN	DCX	BDX	DCON MS	LF						
												(mm)
D 02290 400	22	24.00	30.00	22	12.00	34.00	CC.. 0602..	US 0206-T08P	SDT T08P	HXX 2	HXX 3	0.10
D 02790 401	27	29.00	40.00	27	15.00	42.00	CC.. 0803..	US 0307-T10P	SDR T10P	HXX 2	HXX 4	0.17
D 02790 409	27	29.00	40.00	27	15.00	42.00	CC.. 09T3..	US 0408-T15P	SDR T15P	HXX 2	HXX 4	0.17
D 03290 401	32	39.00	50.00	32	20.00	45.00	CC.. 0803..	US 0307-T10P	SDR T10P	HXX 2.5	HXX 4	0.03
D 03290 409	32	39.00	50.00	32	20.00	45.00	CC.. 09T3..	US 0408-T15P	SDR T15P	HXX 2.5	HXX 4	0.27
D 04290 300	42	49.00	65.00	42	24.00	56.00	TC.. 16T3..	US 0415-T15P	SDR T15P	HXX 3	HXX 5	0.54
D 04290 402	42	49.00	65.00	42	24.00	56.00	CC.. 1204..	US 0513-T20P	SDR T20P	HXX 3	HXX 5	0.54
D 04290 402N	42	53.00	65.00	42	24.00	56.00	CN.. 1204..	US 0613-H25	HXX 2.5	HXX 3	HXX 5	0.53
D 05490 300	54	63.00	82.00	54	28.00	66.00	TC.. 16T3..	US 0415-T15P	SDR T15P	HXX 3	HXX 6	1.06
D 05490 402	54	63.00	82.00	54	28.00	66.00	CC.. 1204..	US 0513-T20P	SDR T20P	HXX 3	HXX 6	1.06
D 05490 402N	54	63.00	82.00	54	28.00	66.00	CN.. 1204..	US 0613-H25	HXX 2.5	HXX 3	HXX 6	1.06



D90-C

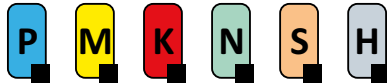

PRAMET

S(P)



Tête d'alésage d'ébauche 90°, diamètres d'alésage moyens - Ø80 à Ø220 mm

Tête d'alésage haute performance à 90° de taille moyenne pour l'ébauche. Convient pour les trous débouchants, borgnes et sécants. Disponible avec plaquettes de type CC ..., TC ..., CN ... et pour des diamètres de trous de Ø80 à Ø220 mm dans des tailles d'accouplement de 68 à 200 mm. Haute précision et répétabilité.

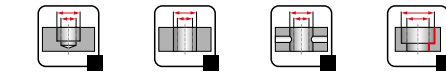
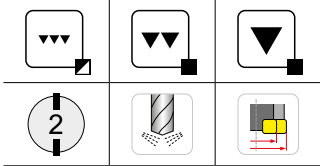
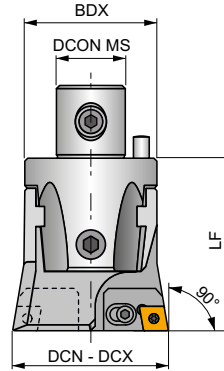

Produit	CZC MS	DCN	DCX	BDX	DCON MS	LF										
D 06890 300	68	80.00	102.00	68	36.00	86.00	2CT 90 300	US 0616	HXK 5	TC.. 16T3..	US 0408-T15P	SDR T15P	HXK 4	HXK 8	2.17	
D 06890 402	68	80.00	102.00	68	36.00	86.00	2CT 90 402	US 0616	HXK 5	CC.. 1204..	US 0509-T20P	SDR T20P	HXK 4	HXK 8	2.15	
D 06890 402N	68	80.00	102.00	68	36.00	86.00	2CT 90 402 N	US 0616	HXK 5	CN.. 1204..	US 0613-H25	HXK 2.5	HXK 4	HXK 8	2.18	
D 08590 300	85	100.00	125.00	85	50.00	100.00	3CT 90 300	US 0625	HXK 5	TC.. 16T3..	US 0415-T15P	SDR T15P	HXK 5	HXK 8	4.52	
D 08590 402	85	100.00	125.00	85	50.00	100.00	3CT 90 402	US 0625	HXK 5	CC.. 1204..	US 0513-T20P	SDR T20P	HXK 5	HXK 8	4.12	
D 08590 402 N	85	100.00	125.00	85	50.00	100.00	3CT 90 402 N	US 0625	HXK 5	CN.. 1204..	US 0613-H25	HXK 2.5	HXK 5	HXK 8	4.17	
D 10090 300	100	125.00	160.00	110	60.00	100.00	3CT 90 300	US 0625	HXK 5	TC.. 16T3..	US 0415-T15P	SDR T15P	HXK 5	HXK 8	6.54	
D 10090 402	100	125.00	160.00	110	60.00	100.00	3CT 90 402	US 0625	HXK 5	CC.. 1204..	US 0513-T20P	SDR T20P	HXK 5	HXK 8	6.56	
D 10090 402 N	100	125.00	160.00	110	60.00	100.00	3CT 90 402 N	US 0625	HXK 5	CN.. 1204..	US 0613-H25	HXK 2.5	HXK 5	HXK 8	6.40	
D 20090 300	200	160.00	220.00	145	60.00	100.00	3CT 90 300	US 0625	HXK 5	TC.. 16T3..	US 0415-T15P	SDR T15P	HXK 5	HXK 8	8.90	
D 20090 402	200	160.00	220.00	145	60.00	100.00	3CT 90 402	US 0625	HXK 5	CC.. 1204..	US 0513-T20P	SDR T20P	HXK 5	HXK 8	8.89	
D 20090 402 N	200	160.00	220.00	145	60.00	100.00	3CT 90 402 N	US 0625	HXK 5	CN.. 1204..	US 0613-H25	HXK 2.5	HXK 5	HXK 8	8.91	



D90-BB

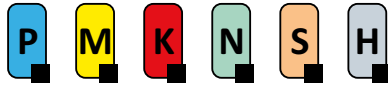

PRAMET

S(P)



Tête d'alésage d'ébauche 90°, gros diamètres d'alésage - Ø220 à Ø500 mm

Grande tête d'alésage haute performance à 90° pour l'ébauche. Convient pour les trous débouchants, borgnes et sécants. Disponible avec plaquettes de type CC..., TC..., CN... et pour des diamètres de trous de Ø220 à Ø500 mm dans des tailles d'accouplement de 300 à 500 mm. Haute précision et répétabilité.

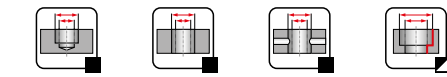
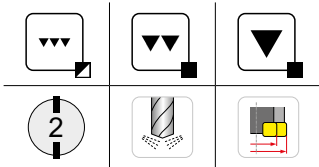
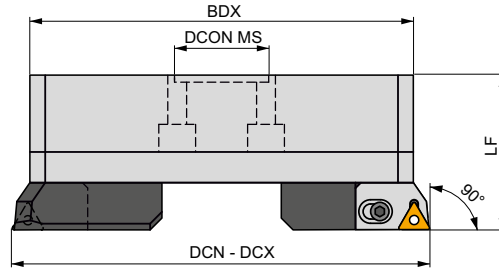

Produit	CZC MS	DCN	DCX	BDX	DCON MS	LF										kg
	(mm)	(mm)	(mm)	(mm)	(mm)	(mm)										
D 30090 300	300	220.00	320.00	202	60.00	90.00	3CT 90 300	US 0625	HXK 5	TC.. 16T3..	US 0415-T15P	SDRT15P	HXK 5	HXK 4	9.45	
D 30090 402	300	220.00	320.00	202	60.00	90.00	3CT 90 402	US 0625	HXK 5	CC.. 1204..	US 0513-T20P	SDRT20P	HXK 5	HXK 4	9.47	
D 30090 402 N	300	220.00	320.00	202	60.00	90.00	3CT 90 402 N	US 0625	HXK 5	CN.. 1204..	US 0613-H25	HXK 2.5	HXK 5	HXK 4	9.56	
D 40090 300	400	290.00	400.00	272	60.00	90.00	3CT 90 300	US 0625	HXK 5	TC.. 16T3..	US 0415-T15P	SDRT15P	HXK 5	HXK 4	12.98	
D 40090 402	400	290.00	400.00	272	60.00	90.00	3CT 90 402	US 0625	HXK 5	CC.. 1204..	US 0513-T20P	SDRT20P	HXK 5	HXK 4	12.98	
D 40090 402 N	400	290.00	400.00	272	60.00	90.00	3CT 90 402 N	US 0625	HXK 5	CN.. 1204..	US 0613-H25	HXK 2.5	HXK 5	HXK 4	12.98	
D 50090 300	500	370.00	500.00	352	60.00	90.00	3CT 90 300	US 0625	HXK 5	TC.. 16T3..	US 0415-T15P	SDRT15P	HXK 5	HXK 4	16.58	
D 50090 402	500	370.00	500.00	352	60.00	90.00	3CT 90 402	US 0625	HXK 5	CC.. 1204..	US 0513-T20P	SDRT20P	HXK 5	HXK 4	16.74	
D 50090 402 N	500	370.00	500.00	352	60.00	90.00	3CT 90 402 N	US 0625	HXK 5	CN.. 1204..	US 0613-H25	HXK 2.5	HXK 5	HXK 4	16.63	

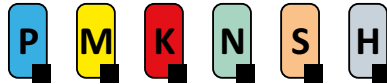
**F75****PRAMET****S****Tête d'alésage de finition 75°, petits diamètres d'alésage - Ø24 à Ø82 mm**

Petite tête d'alésage haute performance à 75° pour la finition. Convient pour l'alésage de trous débouchants et borgnes, le chanfreinage par interpolation hélicoïdale et l'alésage de trous sécants. Disponible avec plaquettes de type CC... et TC... Disponible pour une plage de diamètres de trou de Ø24 à Ø82 mm dans des tailles d'accouplement de 22 à 42 mm. Haute précision et répétabilité.

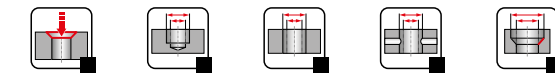
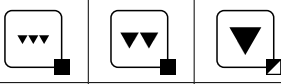
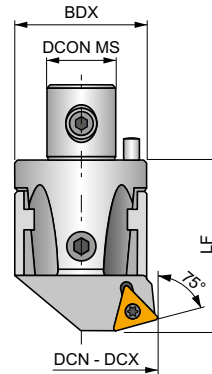

Produit	CZC MS	DCN	DCX	BDX	DCON MS	LF						
		(mm)	(mm)	(mm)	(mm)	(mm)						
A 02275 400	22	24.00	30.00	22	12.00	34.00	CC.. 0602..	US 0206-T08P	SDR T08P	HXK 2	HXK 3	0.10
A 02775 401	27	29.00	40.00	27	15.00	42.00	CC.. 0803..	US 0307-T10P	SDR T10P	HXK 2	HXK 4	0.17
A 02775 409	27	29.00	40.00	27	15.00	42.00	CC.. 09T3..	US 0408-T15P	SDR T15P	HXK 2	HXK 4	0.17
A 03275 401	32	39.00	50.00	32	20.00	45.00	CC.. 0803..	US 0307-T10P	SDR T10P	HXK 2.5	HXK 4	0.26
A 03275 409	32	39.00	50.00	32	20.00	45.00	CC.. 09T3..	US 0408-T15P	SDR T15P	HXK 2.5	HXK 4	0.26
A 04275 300	42	49.00	65.00	42	24.00	56.00	TC.. 16T3..	US 0307-T10P	SDR T10P	HXK 3	HXK 5	0.51
A 05475 300	54	63.00	82.00	54	28.00	66.00	TC.. 16T3..	US 0415-T15P	SDR T15P	HXK 3	HXK 6	1.01



F75-C

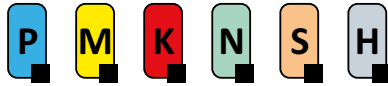

PRAMET

S(P)



Tête d'alésage de finition 75°, diamètres d'alésage moyens - Ø80 à Ø220 mm

Tête d'alésage haute performance à 75° de taille moyenne pour la finition. Convient pour l'alésage de trous débouchants et borgnes, le chanfreinage par interpolation hélicoïdale et l'alésage de trous sécants. Disponible avec plaquettes de type CC ..., TC ..., CN ... Disponible pour une plage de diamètres de trous de Ø80 à Ø220 mm dans des tailles d'accouplement de 68 à 200 mm. Haute précision et répétabilité.

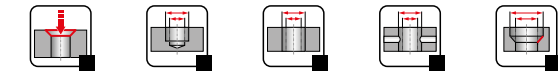
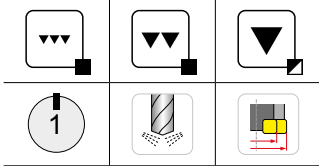
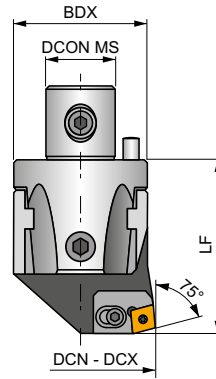

Produit	CZC MS	DCN	DCX	BDX	DCON MS	LF										
A 06875 300	68	80.00	102.00	68	36.00	86.00	2CT 75 300	US 0616	HXK 5	TC.. 16T3..	US 0408-T15P	SDRT15P	HXK 5	HXK 8	2.02	
A 06875 402	68	80.00	102.00	68	36.00	86.00	2CT 75 402	US 0616	HXK 5	CC.. 1204..	US 0509-T20P	SDRT20P	HXK 5	HXK 8	2.03	
A 06875 402 N	68	80.00	102.00	68	36.00	86.00	2CT 75 402 N	US 0616	HXK 5	CN.. 1204..	US 0613-H25	HXK 2.5	HXK 5	HXK 8	2.04	
A 08575 300	85	100.00	125.00	85	50.00	100.00	3CT 75 300	US 0625	HXK 5	TC.. 16T3..	US 0415-T15P	SDRT15P	HXK 6	HXK 8	3.89	
A 08575 402	85	100.00	125.00	85	50.00	100.00	3CT 75 402	US 0625	HXK 5	CC.. 1204..	US 0513-T20P	SDRT20P	HXK 6	HXK 8	3.88	
A 08575 402 N	85	100.00	125.00	85	50.00	100.00	3CT 75 402 N	US 0625	HXK 5	CN.. 1204..	US 0613-H25	HXK 2.5	HXK 6	HXK 8	3.90	
A 10075 300	100	125.00	160.00	110	60.00	100.00	3CT 75 300	US 0625	HXK 5	TC.. 16T3..	US 0415-T15P	SDRT15P	HXK 6	HXK 8	6.22	
A 10075 402	100	125.00	160.00	110	60.00	100.00	3CT 75 402	US 0625	HXK 5	CC.. 1204..	US 0513-T20P	SDRT20P	HXK 6	HXK 8	6.24	
A 10075 402 N	100	125.00	160.00	110	60.00	100.00	3CT 75 402 N	US 0625	HXK 5	CN.. 1204..	US 0613-H25	HXK 2.5	HXK 6	HXK 8	6.25	
A 20075 300	200	160.00	220.00	145	60.00	100.00	3CT 75 300	US 0625	HXK 5	TC.. 16T3..	US 0415-T15P	SDRT15P	HXK 6	HXK 8	8.30	
A 20075 402	200	160.00	220.00	145	60.00	100.00	3CT 75 402	US 0625	HXK 5	CC.. 1204..	US 0513-T20P	SDRT20P	HXK 6	HXK 8	8.33	
A 20075 402 N	200	160.00	220.00	145	60.00	100.00	3CT 75 402 N	US 0625	HXK 5	CN.. 1204..	US 0613-H25	HXK 2.5	HXK 6	HXK 8	8.33	



F75-BB

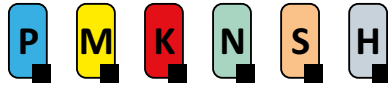

PRAMET

S(P)



Tête d'alésage de finition 75°, gros diamètres d'alésage - Ø220 à Ø500 mm

Grande tête d'alésage haute performance à 75° pour la finition. Convient pour l'alésage de trous débouchants et borgnes, le chanfreinage par interpolation hélicoïdale et l'alésage de trous sécants. Disponible avec plaquettes de type CC..., TC..., CN... Disponible pour une plage de diamètres de trou de Ø220 à Ø500 mm dans des tailles d'accouplement de 300 à 500 mm. Haute précision et répétabilité.

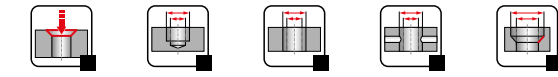
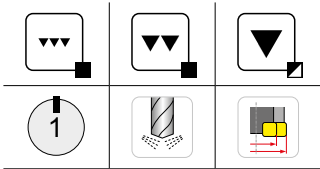
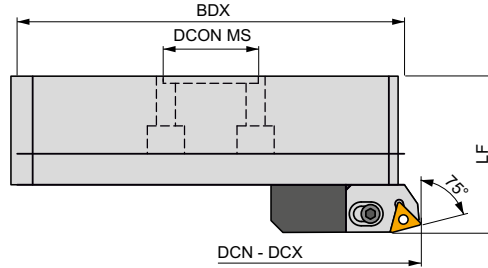

Produit	CZC MS	DCN	DCX	BDX	DCON MS	LF										
A 30075 300	300	220.00	320.00	202	60.00	90.00	3CT 75 300	US 0625	HXK 5	TC.. 16T3..	US 0415-T15P	SDR T15P	HXK 5	HXK 4	8.75	
A 30075 402	300	220.00	320.00	202	60.00	90.00	3CT 75 402	US 0625	HXK 5	CC.. 1204..	US 0513-T20P	SDR T20P	HXK 5	HXK 4	8.75	
A 30075 402 N	300	220.00	320.00	202	60.00	90.00	3CT 75 402 N	US 0625	HXK 5	CN.. 1204..	US 0613-H25	HXK 2.5	HXK 5	HXK 4	8.30	
A 40075 300	400	290.00	400.00	272	60.00	90.00	3CT 75 300	US 0625	HXK 5	TC.. 16T3..	US 0415-T15P	SDR T15P	HXK 5	HXK 4	12.20	
A 40075 402	400	290.00	400.00	272	60.00	90.00	3CT 75 402	US 0625	HXK 5	CC.. 1204..	US 0513-T20P	SDR T20P	HXK 5	HXK 4	12.20	
A 40075 402 N	400	290.00	400.00	272	60.00	90.00	3CT 75 402 N	US 0625	HXK 5	CN.. 1204..	US 0613-H25	HXK 2.5	HXK 5	HXK 4	12.15	
A 50075 300	500	370.00	500.00	352	60.00	90.00	3CT 75 300	US 0625	HXK 5	TC.. 16T3..	US 0415-T15P	SDR T15P	HXK 5	HXK 4	16.31	
A 50075 402	500	370.00	500.00	352	60.00	90.00	3CT 75 402	US 0625	HXK 5	CC.. 1204..	US 0513-T20P	SDR T20P	HXK 5	HXK 4	16.31	
A 50075 402 N	500	370.00	500.00	352	60.00	90.00	3CT 75 402 N	US 0625	HXK 5	CN.. 1204..	US 0613-H25	HXK 2.5	HXK 5	HXK 4	16.00	

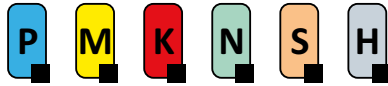
**F90**

PRAMET

S(P)

**Tête d'alésage de finition 90°, petits diamètres d'alésage - Ø24 à Ø82 mm**

Petite tête d'alésage haute performance à 90° pour la finition. Convient pour les trous débouchants, borgnes et sécants. Disponible avec plaquettes de type CC., TC., CN... Disponible pour une plage de diamètres de trou de Ø24 à Ø82 mm dans des tailles d'accouplement de 22 à 54 mm. Haute précision et répétabilité.

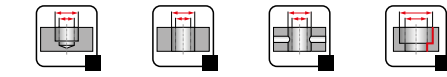
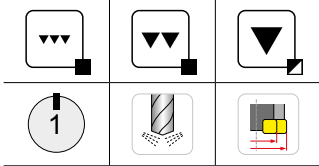
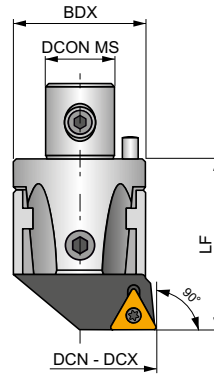

Produit	CZC MS	DCN	DCX	BDX	DCON MS	LF						
A 02290 400	22	24.00	30.00	22	12.00	34.00	CC.. 0602..	US 0206-T08P	SDR T08P	HXK 2	HXK 3	0.10
A 02790 401	27	29.00	40.00	27	15.00	42.00	CC.. 0803..	US 0307-T10P	SDR T10P	HXK 2	HXK 4	0.17
A 02790 409	27	29.00	40.00	27	15.00	42.00	CC.. 09T3..	US 0408-T15P	SDR T15P	HXK 2	HXK 4	0.16
A 03290 300	32	39.00	50.00	32	20.00	45.00	TC.. 16T3..	US 0408-T15P	SDR T15P	HXK 2.5	HXK 4	0.26
A 03290 401	32	39.00	50.00	32	20.00	45.00	CC.. 0803..	US 0206-T08P	SDR T08P	HXK 2.5	HXK 4	0.26
A 03290 409	32	39.00	50.00	32	20.00	45.00	CC.. 09T3..	US 0408-T15P	SDR T15P	HXK 2.5	HXK 4	0.26
A 04290 300	42	49.00	65.00	42	24.00	56.00	TC.. 16T3..	US 0415-T15P	SDR T15P	HXK 3	HXK 5	0.51
A 04290 402	42	49.00	65.00	42	24.00	56.00	CC.. 1204..	US 0513-T20P	SDR T20P	HXK 3	HXK 5	0.51
A 04290 402 N	42	49.00	65.00	42	24.00	56.00	CN.. 1204..	US 0613-H25	HXK 2.5	HXK 3	HXK 5	0.50
A 05490 300	54	63.00	82.00	54	28.00	66.00	TC.. 16T3..	US 0415-T15P	SDR T15P	HXK 3	HXK 6	1.01
A 05490 402	54	63.00	82.00	54	28.00	66.00	CC.. 1204..	US 0513-T20P	SDR T20P	HXK 3	HXK 6	1.03
A 05490 402 N	54	63.00	82.00	54	28.00	66.00	CN.. 1204..	US 0613-H25	HXK 2.5	HXK 3	HXK 6	1.01



F90-C

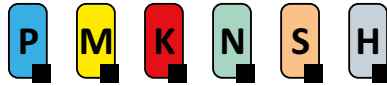

PRAMET

S(P)



Tête d'alésage de finition 90°, diamètres d'alésage moyens - Ø80 à Ø220 mm

Tête d'alésage haute performance à 90° de taille moyenne pour la finition. Convient pour les trous débouchants, borgnes et sécants. Disponible avec plaquettes de type CC ..., TC ..., CN ... Disponible pour une plage de diamètres de trous de Ø80 à Ø220 mm dans des tailles d'accouplement de 68 à 145 mm. Haute précision et répétabilité.

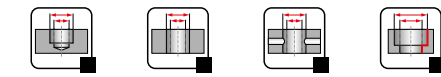
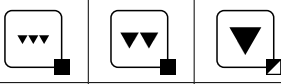
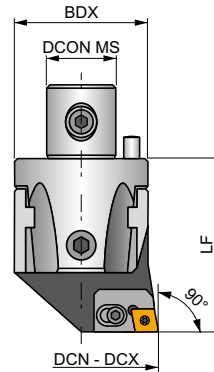

Produit	CZC MS	DCN	DCX	BDX	DCON MS	LF										
		(mm)	(mm)	(mm)	(mm)	(mm)										kg
A 06890 300	68	80.00	102.00	68	36.00	86.00	2CT 90 300	US 0616	HXK 5	TC.. 16T3..	US 0408-T15P	SDR T15P	HXK 5	HXK 8	2.03	
A 06890 402	68	80.00	102.00	68	36.00	86.00	2CT 90 402	US 0616	HXK 5	CC.. 1204..	US 0509-T15P	SDR T15P	HXK 5	HXK 8	2.03	
A 06890 402 N	68	80.00	102.00	68	36.00	86.00	2CT 90 402 N	US 0616	HXK 5	CN.. 1204..	US 0613-H25	HXK 2.5	HXK 5	HXK 8	2.60	
A 08590 300	85	100.00	125.00	85	50.00	100.00	3CT 90 300	US 0625	HXK 5	TC.. 16T3..	US 0415-T15P	SDR T15P	HXK 6	HXK 8	3.90	
A 08590 402	85	100.00	125.00	85	50.00	100.00	3CT 90 402	US 0625	HXK 5	CC.. 1204..	US 0513-T20P	SDR T20P	HXK 6	HXK 8	3.88	
A 08590 402 N	85	100.00	125.00	85	50.00	100.00	3CT 90 402 N	US 0625	HXK 5	CN.. 1204..	US 0613-H25	HXK 2.5	HXK 6	HXK 8	4.04	
A 10090 300	100	125.00	160.00	100	60.00	100.00	3CT 90 300	US 0625	HXK 5	TC.. 16T3..	US 0415-T15P	SDR T15P	HXK 6	HXK 8	6.24	
A 10090 402	100	125.00	160.00	100	60.00	100.00	3CT 90 402	US 0625	HXK 5	CC.. 1204..	US 0513-T20P	SDR T20P	HXK 6	HXK 8	6.24	
A 10090 402 N	100	125.00	160.00	100	60.00	100.00	3CT 90 402 N	US 0625	HXK 5	CN.. 1204..	US 0613-H25	HXK 2.5	HXK 6	HXK 8	6.26	
A 20090 300	200	160.00	220.00	145	60.00	100.00	3CT 90 300	US 0625	HXK 5	TC.. 16T3..	US 0415-T15P	SDR T15P	HXK 6	HXK 8	8.30	
A 20090 402	200	160.00	220.00	145	60.00	100.00	3CT 90 402	US 0625	HXK 5	CC.. 1204..	US 0513-T20P	SDR T20P	HXK 6	HXK 8	8.29	
A 20090 402 N	200	160.00	220.00	145	60.00	100.00	3CT 90 402 N	US 0625	HXK 5	CN.. 1204..	US 0613-H25	HXK 2.5	HXK 6	HXK 8	8.33	



F90-BB



PRAMET

S(P)



Tête d'alésage de finition 90°, gros diamètres d'alésage - Ø220 à Ø500 mm

Grande tête d'alésage haute performance à 90° pour la finition. Convient pour les trous débouchants, borgnes et sécants. Disponible avec plaquettes de type CC..., TC..., CN... Disponible pour une plage de diamètres de trou de Ø220 à Ø500 mm dans des tailles d'accouplement de 202 à 352 mm. Haute précision et répétabilité.

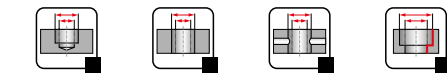
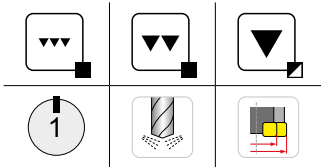
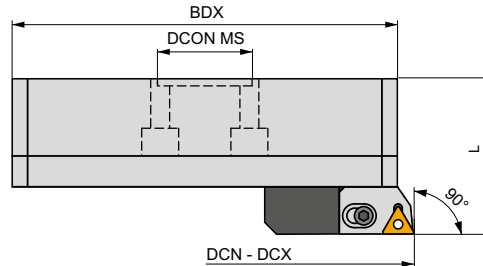

Produit	CZC MS	DCN	DCX	BDX	DCON MS	LF										
		(mm)	(mm)	(mm)	(mm)	(mm)										
A 30090 300	300	220.00	320.00	202	60.00	90.00	3CT 90 300	US 0625	HXK 5	TC.. 16T3..	US 0415-T15P	SDRT15P	HXK 5	HXK 4	8.74	
A 30090 402	300	220.00	320.00	202	60.00	90.00	3CT 90 402	US 0625	HXK 5	CC.. 1204..	US 0513-T20P	SDRT20P	HXK 5	HXK 4	8.82	
A 30090 402 N	300	220.00	320.00	202	60.00	90.00	3CT 90 402 N	US 0625	HXK 5	CN.. 1204..	US 0613-H25	HXK 2.5	HXK 5	HXK 4	8.75	
A 40090 300	400	290.00	400.00	272	60.00	90.00	3CT 90 300	US 0625	HXK 5	TC.. 16T3..	US 0415-T15P	SDRT15P	HXK 5	HXK 4	12.19	
A 40090 402	400	290.00	400.00	272	60.00	90.00	3CT 90 402	US 0625	HXK 5	CC.. 1204..	US 0513-T20P	SDRT20P	HXK 5	HXK 4	12.50	
A 40090 402 N	400	290.00	400.00	272	60.00	90.00	3CT 90 402 N	US 0625	HXK 5	CN.. 1204..	US 0613-H25	HXK 2.5	HXK 5	HXK 4	12.20	
A 50090 300	500	370.00	500.00	352	60.00	90.00	3CT 90 300	US 0625	HXK 5	TC.. 16T3..	US 0415-T15P	SDRT15P	HXK 5	HXK 4	16.08	
A 50090 402	500	370.00	500.00	352	60.00	90.00	3CT 90 402	US 0625	HXK 5	CC.. 1204..	US 0513-T20P	SDRT20P	HXK 5	HXK 4	16.20	
A 50090 402 N	500	370.00	500.00	352	60.00	90.00	3CT 90 402 N	US 0625	HXK 5	CN.. 1204..	US 0613-H25	HXK 2.5	HXK 5	HXK 4	16.00	



MB-H

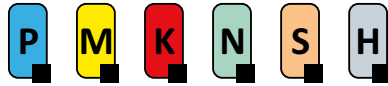

PRAMET

S



Micro-tête d'alésage, alésages ultra petits - Ø8 à Ø38 mm

Tête micro-alésage haute performance et haute précision avec une répétabilité élevée. Convient pour les trous débouchants, borgnes, épaulés et sécants. La taille de la tête peut supporter des outils d'alésage de Ø6,0 à Ø16,0 mm. Disponible dans les tailles d'accouplement de 27 à 42 mm.

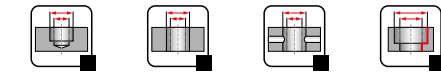
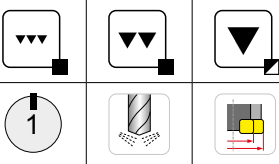
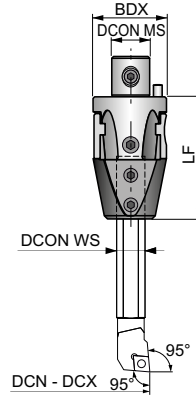

Produit	CZC MS	DCN	DCX	BDX	DCON MS	DCON WS	LB			
		(mm)	(mm)	(mm)	(mm)	(mm)				
A 027 006	27	8.00	20.00	27	15.00	6.00	50.00	HXK 2	HXK 4	0.20
A 027 008	27	10.00	21.00	27	15.00	8.00	50.00	HXK 2	HXK 4	0.19
A 032 008	32	10.00	21.00	32	20.00	8.00	58.00	HXK 2.5	HXK 4	0.32
A 032 010	32	13.00	25.00	32	20.00	10.00	58.00	HXK 2.5	HXK 4	0.32
A 042 010	42	13.00	29.00	42	24.00	10.00	70.00	HXK 3	HXK 5	0.64
A 042 012	42	16.00	34.00	42	24.00	12.00	70.00	HXK 3	HXK 5	0.64
A 042 016	42	20.00	38.00	42	24.00	16.00	70.00	HXK 3	HXK 5	0.62



ISO BARS

PRAMET



Barres d'alésage pour micro-tête d'alésage - Diamètre de queue Ø6 à Ø16 mm

Convient pour les trous borgnes, débouchants, épaulés et sécants. Disponible avec plaquettes de type EP .., TC .. et CC ...

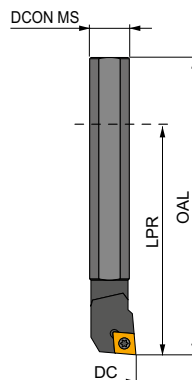

Produit	DCON MS	DC	OAL	LPR				Carbide	
	(mm)	(mm)	(mm)	(mm)					
S06E SELPR 05-B	6.00	8.00	70.0	46	EP.. 0502..	US 0205-T07P	SDR T07P	–	0.04
S08F SCLCR 06-B	8.00	10.00	80.0	50	CC.. 0602..	US 0205-T08P	SDR T08P	–	0.04
S10G SCLCR 06-B	10.00	13.00	90.0	54	CC.. 0602..	US 0206-T08P	SDR T08P	–	0.06
S12H SCLCR 06-B	12.00	16.00	100.0	64	CC.. 0602..	US 0206-T08P	SDR T08P	–	0.11
S16J SCLCR 09-B	16.00	20.00	110.0	74	CC.. 09T3..	US 0408-T15P	SDR T15P	–	0.18
S16J STFCR 09-B	16.00	20.00	110.0	74	TC.. 0902..	US 0206-T07P	SDR T07P	–	0.18
S16J STFCR 16-B	16.00	20.00	110.0	74	TC.. 16T3..	US 0408-T15P	SDR T15P	–	0.18
C08G SCLCR 06	8.00	10.00	90.0	60	CC.. 0602..	US 0205-T08P	SDR T08P	✓	1.00
C10J SCLCR 06	10.00	13.00	110.0	74	CC.. 0602..	US 0206-T08P	SDR T08P	✓	0.13
C12K SCLCR 06	12.00	16.00	125.0	89	CC.. 0602..	US 0206-T08P	SDR T08P	✓	0.20
C16L SCLCR 09	16.00	20.00	140.0	104	CC.. 09T3..	US 0408-T15P	SDR T15P	✓	0.38



ISO BARS A042



Barres d'alésage pour micro tête d'alésage Micro A042

Barres d'alésage avec diamètre de queue surdimensionné Ø16 mm. Convient pour les trous borgnes, débouchants, épaulés et sécants. Disponible avec plaquettes de type EP ..., TC .. et CC ...

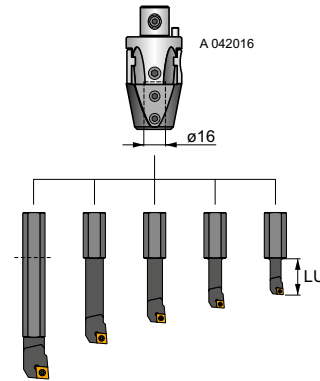

Produit	DCN	DCX	LU				
	(mm)	(mm)	(mm)				
S06/16 SELPR 05	8.00	26.00	25.00	EP.. 0502..	US 0205-T07P	SDR T07P	0.08
S06/16 STFCR 06	8.00	26.00	25.00	TC.. 06T1..	US 0405-T06P	SDR T06P	0.08
S08/16 SCLCR 06	10.00	28.00	35.00	CC.. 0602..	US 0205-T08P	SDR T08P	0.09
S08/16 STFCR 06	10.00	28.00	35.00	TC.. 06T1..	US 0405-T06P	SDR T06P	0.07
S10/16 SCLCR 06	13.00	31.00	45.00	CC.. 0602..	US 0206-T08P	SDR T08P	0.10
S10/16 STFCR 09	13.00	31.00	45.00	TC.. 0902..	US 0206-T07P	SDR T07P	0.10
S12/16 SCLCR 06	16.00	34.00	57.00	CC.. 0602..	US 0206-T08P	SDR T08P	0.13
S12/16 STFCR 09	16.00	34.00	57.00	TC.. 0902..	US 0206-T07P	SDR T07P	0.13
S16/16 SCLCR 09	20.00	38.00	73.00	CC.. 09T3..	US 0408-T15P	SDR T15P	0.18
S16/16 STFCR 09	20.00	38.00	73.00	TC.. 0902..	US 0206-T07P	SDR T07P	0.18
S16/16 STFCR 16	20.00	38.00	73.00	TC.. 0902..	US 0408-T15P	SDR T15P	0.18



ACCESSOIRES



DÉSIGNATION DU CARTOUCHE

1	2	3	4
2CT	90	402 N	S

1	2	3	4
Type d'outil	Angle d'attaque	Code du logement de plaquette	Version
2CT	30	300 TC..16T3.	S Décalé
3CT	45	402 CC..1204..	
	75	402N CN..1204..	
	90		



Alésage symétrique

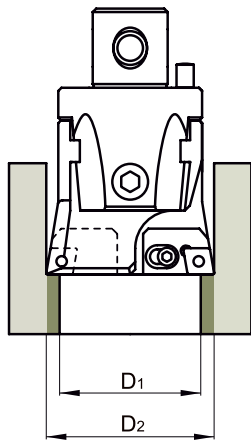

2CT □□ □□□ + 2CT □□ □□□
 3CT □□ □□□ + 3CT □□ □□□

Alésage décalé

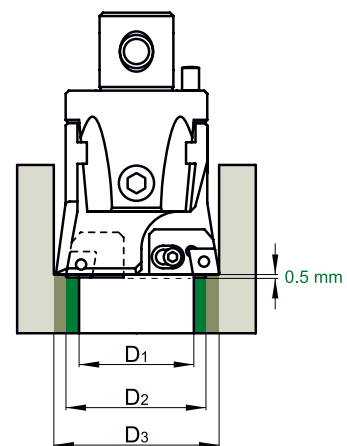

2CT □□ □□□ S + 2CT □□ □□□
 3CT □□ □□□ S + 3CT □□ □□□



CART-BS-SPC

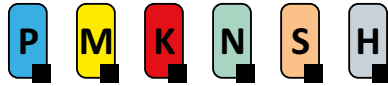

PRAMET

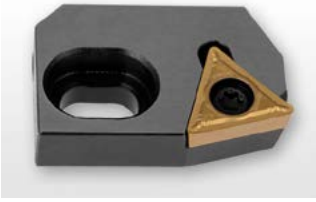

Cartouches spéciales 2CT et 3CT pour tête d'alésage

Cartouches spéciales pour tête d'alésage, tailles 2CT et 3CT disponibles en différents angles d'attaque 30 ° ou 45 °. Convient aux plaquettes TC ..., CC ..., CN ... pour les applications d'alésage d'ébauche et de finition.

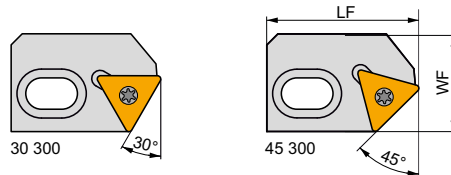

Produit	WF	LF								
	(mm)	(mm)								
2CT 30 300	22.5	35.00	US 0616	HXK 5	US 0430	HXK 2	TC.. 16T3..	US 0408-T15P	SDR T15P	0.59
2CT 45 300	22.5	35.00	US 0616	HXK 5	US 0430	HXK 2	TC.. 16T3..	US 0408-T15P	SDR T15P	0.05
2CT 90 300 S	23	33.00	US 0616	HXK 5	US 0430	HXK 2	TC.. 16T3..	US 0408-T15P	SDR T15P	0.05
2CT 90 402 N S	23	33.00	US 0616	HXK 5	US 0430	HXK 2	CN.. 1204.. L	US 0613-H25	HXK 2.5	0.07
2CT 90 402 S	23	33.00	US 0616	HXK 5	US 0430	HXK 2	CC.. 1204..	US 0509-T20P	SDR T20P	0.05
3CT 30 300	28	39.00	US 0625	HXK 5	US 0635	HXK 3	TC.. 16T3..	US 0415-T15P	SDR T15P	0.10
3CT 45 300	28	39.00	US 0625	HXK 5	US 0635	HXK 3	TC.. 16T3..	US 0415-T15P	SDR T15P	0.10
3CT 90 300 S	28.5	37.00	US 0625	HXK 5	US 0635	HXK 3	TC.. 16T3..	US 0415-T15P	SDR T15P	0.10
3CT 90 402 N S	28.5	37.00	US 0625	HXK 5	US 0635	HXK 3	CN.. 1204.. L	US 0613-H25	HXK 2.5	0.11
3CT 90 402 S	28.5	37.00	US 0625	HXK 5	US 0635	HXK 3	CC.. 1204..	US 0513-T20P	SDR T20P	0.09



CART-BS-STD

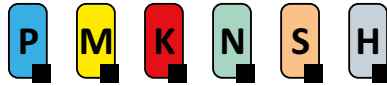

Cartouches standards 2CT et 3CT pour tête d'alésage

Cartouches standards pour tête d'alésage, tailles 2CT et 3CT disponibles dans différents angles d'attaque 75 ° ou 90 °. Convient aux plaquettes TC .., CC .., CN .. pour les applications d'alésage d'ébauche et de finition.

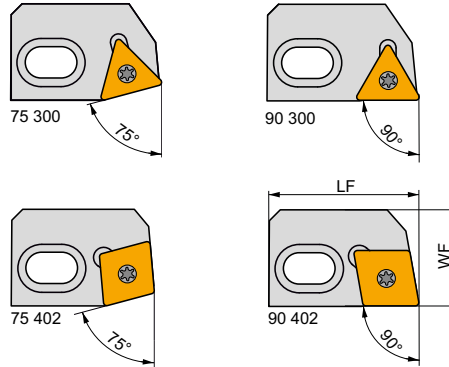

Produit	WF	LF									kg
	(mm)	(mm)									
2CT 75 300	22.5	35.00	US 0616	HXK 5	US 0430	HXK 2	TC.. 16T3..	US 0408-T15P	SDR T15P	0.06	
2CT 75 402	22.5	35.00	US 0616	HXK 5	US 0430	HXK 2	CC.. 1204..	US 0509-T20P	SDR T20P	0.06	
2CT 75 402 N	22.5	35.00	US 0616	HXK 5	US 0430	HXK 2	CN.. 1204.. R	US 0613-H25	HXK 2.5	0.07	
2CT 90 300	22.5	35.00	US 0616	HXK 5	US 0430	HXK 2	TC.. 16T3..	US 0408-T15P	SDR T15P	0.05	
2CT 90 402	22.5	35.00	US 0616	HXK 5	US 0430	HXK 2	CC.. 1204..	US 0509-T20P	SDR T20P	0.05	
2CT 90 402 N	22.5	35.00	US 0616	HXK 5	US 0430	HXK 2	CN.. 1204.. L	US 0613-H25	HXK 2.5	0.07	
3CT 75 300	28	39.00	US 0625	HXK 5	US 0635	HXK 3	TC.. 16T3..	US 0415-T15P	SDR T15P	0.10	
3CT 75 402	28	39.00	US 0625	HXK 5	US 0635	HXK 3	CC.. 1204..	US 0509-T20P	SDR T20P	0.10	
3CT 75 402 N	28	39.00	US 0625	HXK 5	US 0635	HXK 3	CN.. 1204.. R	US 0613-H25	HXK 2.5	0.12	
3CT 90 300	28	39.00	US 0625	HXK 5	US 0635	HXK 3	TC.. 16T3..	US 0415-T15P	SDR T15P	0.11	
3CT 90 402	28	39.00	US 0625	HXK 5	US 0635	HXK 3	CC.. 1204..	US 0509-T20P	SDR T20P	0.10	
3CT 90 402 N	28	39.00	US 0625	HXK 5	US 0635	HXK 3	CN.. 1204.. L	US 0613-H25	HXK 2.5	0.12	



CHAM-BS

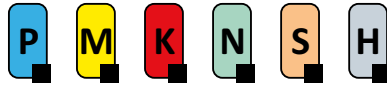

PRAMET

S



Bague de chanfreinage CH-BS pour têtes d'alésage

Bague de chanfreinage à 45° pour système de tête d'alésage, tailles de 22 à 42 mm pour plaquettes DC .. 11T3 .. , et tailles de 54 à 200 mm pour plaquettes DC .. 1504 ..

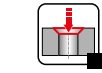
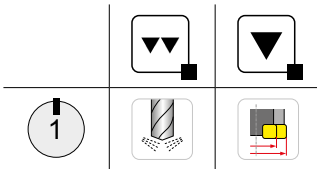
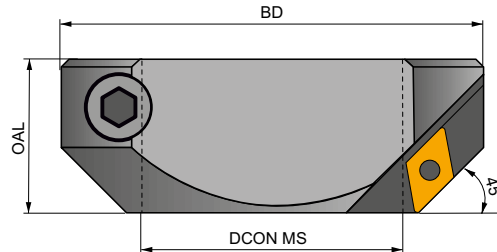

















Produit	CZC MS	DCON MS	BD	OAL					
		(mm)	(mm)	(mm)					
CH 022	22	22.00	43.00	24.0	DC.. 11T3..	US 0408-T15P	SDRT15P	HXK 4	0.11
CH 027	27	27.00	48.00	24.0	DC.. 11T3..	US 0408-T15P	SDRT15P	HXK 4	0.13
CH 032	32	32.00	62.00	30.0	DC.. 11T3..	US 0408-T15P	SDRT15P	HXK 5	0.29
CH 042	42	42.00	72.00	30.0	DC.. 11T3..	US 0408-T15P	SDRT15P	HXK 5	0.38
CH 054	54	54.00	94.00	40.0	DC.. 1504..	US 0513-T20P	SDRT20P	HXK 6	0.89
CH 068	68	68.00	110.00	40.0	DC.. 1504..	US 0513-T20P	SDRT20P	HXK 8	1.23
CH 085	85	85.00	145.00	55.0	DC.. 1504..	US 0513-T20P	SDRT20P	HXK 10	2.70
CH 100	100	100.00	170.00	60.0	DC.. 1504..	US 0513-T20P	SDRT20P	HXK 14	4.14
CH 200	200	100.00	200.00	60.0	DC.. 1504..	US 0513-T20P	SDRT20P	HXK 14	5.80



PLAQUETTES D'ALÉSAGE







PLAQUETTES D'ALÉSAGE – RECHERCHE

CCGT  388	CCGW CBN  390	CCMT  390	CCMW  393
CNGA CBN  394	CNGG  395	CNMA  395	CNMG  396
DCMT  398	DCMW  399	DCMW PCD  399	
EPGX  400	EPMT  400		
TCGT  401	TCMT  402	TCMW  403	

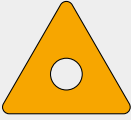
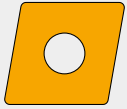

PLAQUETTES D'ALÉSAGE

Forme	Désignation de poche	Code ISO
	300	TC.. 16T3..
	400 401 402 409	CC.. 0602.. CC.. 0803.. CC.. 1204.. CC.. 09T3..
	402N	CN.. 1204..
		EP.. 0502..
		DC..11T3.. DC..1504..

D'autres options de plaquettes peuvent être trouvées dans la partie tournage. Les détails des géométries sont également dans la partie tournage.



NUANCES PLAQUETTES D'ALÉSAGE – RECHERCHE

Identification de la nuance	Domaine d'application	Application	Avance	Vitesse de coupe	Résistance en conditions de travail compliquées	Revêtement	Couleur	Substrat	Bénéfice airrosage	Description de la nuance
T9315	P05 - P25	■				MT-CVD		FGM	++	Une nuance polyvalente avec d'excellentes propriétés de résistance à l'usure, même dans des conditions de coupe intenses. Elle convient également aux opérations de coupes interrompues. Avec des propriétés équilibrées, cette nuance est un excellent choix pour une large gamme d'opérations de tournage. Elle ne convient pas pour des opérations à vitesse de coupe lente.
	K05 - K25	■								
	H10 - H20	■								
T9325	P15 - P35	■				MT-CVD		FGM	++	D'un point de vue technologique, il s'agit d'une nuance extrêmement polyvalente. Présentant une résistance élevée aux dommages mécaniques dans des conditions de coupe difficiles, elle conserve une excellente résistance à l'usure. Cette nuance nécessite des vitesses de coupe élevées.
	M10 - M30	■								
	K15 - K35	■								
	S10 - S20	■								
T9335	P20 - P45	■				MT-CVD		FGM	+++	L'une des nuances les plus résistantes ; elle est particulièrement adaptée aux conditions de coupe difficiles, à des avances moyennes à élevées et à des vitesses de coupe moyennes. Par rapport à ses prédécesseurs (M15 – M40), elle est non seulement plus robuste, mais aussi plus résistante à l'abrasion. Elle convient donc aux conditions de coupe intensives.
	M15 - M40	■								
	S15 - S25	■								
T7325	P15 - P35	■				MT-CVD		FGM	+++	L'une des nuances de tournage les plus universelles. Spécialement conçue pour l'usinage de l'acier inoxydable. Elle offre un équilibre optimal entre résistance à l'usure et fiabilité des performances. Elle convient à une grande variété d'applications de tournage.
	M10 - M25	■								
	S10 - S25	■								
T7335	P20 - P40	■				MT-CVD		FGM	+++	Nuance avec substrat à gradient fonctionnel, présentant une très grande fiabilité opérationnelle et une très bonne résistance à l'usure. Elle convient parfaitement à l'usinage de matériaux très tenaces de type M20 – M40.
	M20 - M40	■								
	S15 - S25	■								
T5305	P05 - P15	■				MT-CVD		H	+	Nuance présentant une très haute résistance à l'usure chimique ; elle convient aux opérations de finition à vitesse de coupe élevée. Grâce à sa grande résistance à l'abrasion, elle est également adaptée à l'usinage productif de matériaux trempés et traités, K01 – K15.
	K01 - K15	■								
	H05 - H15	■								
T5315	P10 - P25	■				MT-CVD		H	+	Nuance destinée principalement à des usinages productifs. Elle présente une résistance élevée à l'abrasion et une bonne fiabilité opérationnelle. Grâce à ses propriétés, elle est particulièrement adaptée aux opérations d'ébauche et de finition dans des conditions de coupe bonnes à légèrement défavorables.
	K10 - K25	■								
	H15 - H25	■								
T8315	P05 - P20	■				PVD		submicron H	++	Offrant une excellente résistance à l'abrasion tout en maintenant une fiabilité opérationnelle supérieure à la moyenne, cette nuance est adaptée aux usinages à des vitesses de coupe moyennes à élevées dans des matériaux durs à copeaux courts.
	M05 - M20	■								
	K05 - K25	■								
	N05 - N25	■								
	S05 - S15	■								
T8330	P25 - P40	■				PVD		submicron H	+++	Sans aucun doute le matériau de coupe le plus polyvalent : cette nuance convient à l'usinage de tous les types de matériaux et pratiquement à tous les types d'opérations de tournage. Ses principaux avantages sont sa grande fiabilité opérationnelle et ses très bonnes propriétés anti-frottement ; elle convient donc aux applications à des vitesses de coupe moyennes et basses.
	M20 - M35	■								
	K20 - K40	■								
	N15 - N30	■								
	S15 - S25	■								
T6310	P01 - P15	■				PVD		ultra submicron H	+++	Nuance de tournage hautement résistante à l'usure avec revêtement de surface PVD. Elle convient aux opérations de finition et aux applications pour lesquelles une arête de coupe aiguisée et une résistance élevée à l'usure en dépouille sont d'une grande importance.
	M01 - M15	■								
	K05 - K20	■								
	N05 - N20	■								
	S01 - S15	■								
H01 - H15	■									



NUANCES PLAQUETTES D'ALÉSAGE – RECHERCHE

Identification de la nuance	Domaine d'application	Application	Avance	Vitesse de coupe	Résistance en conditions de travail compliquées	Revêtement	Couleur	Substrat	Bénéfice arrosage	Description de la nuance
T0315	N05 - N20	■				PVD			++	Nuance submicronique pour le tournage des métaux non ferreux et de leurs alliages, offrant un équilibre entre résistance à l'usure et ténacité. Elle est dotée d'un revêtement unique présentant d'excellentes propriétés anti-frottement.
HF7	M10 - M20	■				×		submicron H	++	Nuance non revêtue qui est principalement destinée à l'usinage des métaux non ferreux ; elle convient également à d'autres matériaux usinés (sauf l'acier). Ce matériau peut être utilisé pour le tournage, le fraisage et même l'alésage.
	K10 - K25	■								
	N10 - N25	■								
H07	M05 - M15	■				×		submicron H	++	Nuance de tournage non revêtue convenant aux applications d'usinage où la résistance à l'oxydation n'est pas le critère dominant de la durée de vie de l'outil. Elle est conçue pour l'usinage d'alliages de Ti. Cette nuance présente une résistance élevée de l'arête de coupe ainsi qu'une bonne résistance à l'usure.
	K10 - K25	■								
	N10 - N30	■								
	S01 - S20	■								
TT310	P10 - P25	■				PVD		cermet	+ / -	Cermet revêtu utilisé pour le tournage de précision et de finition des aciers au carbone et alliés (y compris les aciers inoxydables). Ses excellentes propriétés anti-frottement sont encore améliorées par le revêtement de type PVD.
	M15 - M25	■								
TT010	P01 - P10	■				×		cermet	+ / -	Cermet non revêtu qui convient à l'usinage fin de tous les types d'acier (y compris l'acier inoxydable) à des vitesses d'avance très faibles. Son principal avantage est le rayon minimale de l'arête de coupe et sa grande résistance à l'usure physique et à l'usure chimique.
	M01 - M10	■								
PD1	N05 - N25	■				×		PCD	-	La nuance PKD convient au tournage des métaux non ferreux. C'est un choix idéal pour travailler à des vitesses de coupe élevées et avance faible dans des conditions de travail stables.
TB310	K01 - K10	■				×		CBN	--	Nuance CBN pour l'usinage de matériaux trempés. Elle convient aux usinages à des vitesses de coupe élevées et avance faible dans des conditions de travail stables.
	S05 - S10	■								
	H01 - H10	■								

Substrat	
H	Substrat de base WC-Co
submicron H	Substrat à grains fins base WC-Co (< 1 µm)
ultra submicron H	Substrat à grains très fins base WC-Co (< 0,5 µm)
FGM	Substrat gradient fonctionnel
Cermet	Carbure cémenté sans WC
PCD	Diamant polycristallin
CBN	Nitride de Bore cubique

Revêtement	
MT-CVD	Méthode de revêtement par dépôt chimique à moyenne température
PVD	Méthode de revêtement par dépôt physique à basse température
×	Nuance non revêtue

Bénéfices de l'arrosage	
+++	L'utilisation de l'arrosage est essentielle
++	Arrosage fortement recommandé
+ / -	L'arrosage peut être une option
--	Ne pas utiliser l'arrosage



PLAQUETTES – CODIFICATION ISO

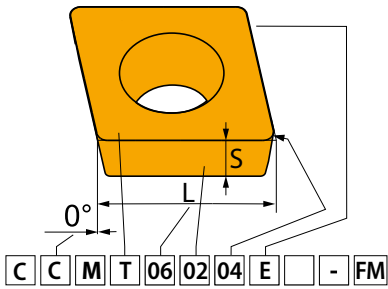

ISO	1	2	3	4
	C	C	M	T
ANSI	1	2	3	4
	C	C	M	T

1				2				4														
Forme de la plaquette				Angle de dépouille de la plaquette				Type de plaquette														
H	O	P	R	A	B	C	D	N	R	F	A	M	G	W	T	Q	U	B	H	C	J	X
S	T	C	D	E	F	G	N															
E	M	V	W																			
L	A	B	K	P	O		Spécial															

3												
Tolérances												
	(mm)						(")					
	M(±)	S(±)	IC(±)	M(±)	S(±)	IC(±)	M(±)	S(±)	IC(±)	M(±)	S(±)	IC(±)
A	0.005	0.025	0.025				.0002"	.001"	.0010"			
F	0.005	0.025	0.013				.0002"	.001"	.0005"			
C	0.013	0.025	0.025				.0005"	.001"	.0010"			
H	0.013	0.025	0.013				.0005"	.001"	.0005"			
E	0.025	0.025	0.025				.0010"	.001"	.0010"			
G	0.025	0.130	0.025				.0010"	.005"	.0010"			
J	0.005	0.025	0.05 – 0.13				.0002"	.001"	.002 – 0.005"			
K	0.013	0.025	0.05 – 0.13				.0005"	.001"	.002 – 0.005"			
L	0.025	0.025	0.05 – 0.13				.0010"	.001"	.002 – 0.005"			
M	0.08 – 0.18	0.130	0.05 – 0.13				.003 – 0.007"	.005"	.002 – 0.005"			
N	0.08 – 0.18	0.025	0.05 – 0.13				.003 – 0.007"	.001"	.002 – 0.005"			
U	0.05 – 0.38	0.130	0.05 – 0.13				.005 – 0.015"	.005"	.003 – 0.010"			

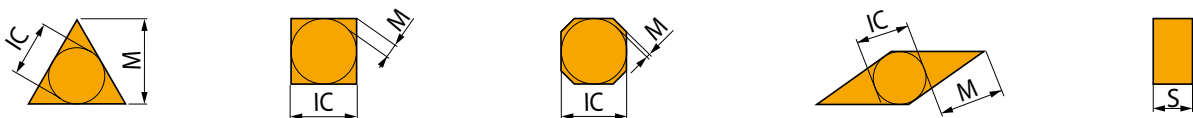



PLAQUETTES – CODIFICATION ISO

5	6	7	8	9	10
06	02	04	E		FM
5	6	7	8	9	10
2	1.5	1	E		FM

5		5											
Longueur de l'arête de coupe (taille de plaquette)													
d=IC	H	O	P	S	T	C	D	E	M	V	W	R	K
(mm)													
3.97				03	06		04			06	02		
4.76				04	08	04	05	04	04	08	L3		
5.56				05	09	05	06	05	05	09	03		
6.35	03	02	04	08	11	06	07	08	08	11	04	06	
7.94	04	03	05	07	13	08	09	06	07	13	05	07	
9.525	05	04	07	09	16	09	11	09	09	16	06	09	16
12.7	07	05	09	12	22	12	15	13	12	22	08	12	
15.875	09	06	11	15	27	16	19	16	15	27	10	15	
19.05	11	07	13	19	33	19	23	19	19	33	13	19	
25.40	14	10	18	25	44	25	31	26	25	44	17	25	
31.75	18	13	23	31	54	32	38	32	31	54	21	31	

6	
Épaisseur de la plaquette	
01	1.59 1/16"
T1	1.98 5/64"
02	2.38 3/32"
03	3.18 1/8"
T3	3.97 5.32"
04	4.76 3/16"
05	5.56 7/32"
06	6.35 1/4"
07	7.94 5/16"
09	9.52 3/8"

7	
Rayon de pointe de la plaquette	
	RE
	(mm) ("")
00	0 0"
02	0.2 1/128"
04	0.4 1/64"
08	0.8 1/32"
12	1.2 3/64"
16	1.6 1/16"
24	2.4 3/32"
32	3.2 1/8"
Plaquettes rondes	
d=I.C.	
(")	00
(mm)	M0

ANSI		
5	6	7
Cercle inscrit	Épaisseur de la plaquette	Rayon de pointe de la plaquette
Symbol	Symbol	Symbol
		RE
		(mm) ("")
1	1	0
1.2	1.2	0.099
1.5	1.5	0.198
1.8	1.8	0.397
2	2	0.794
2.5	2.5	1.191
3	3	1.588
3.5	3.5	1.984
4	4	2.381
5	5	2.778
6	6	3.175
7	7	3.572
8	8	3.969
10	10	4.366
12	12	4.763
		5.160
		5.557
		5.954
		6.351

8		8	
Configuration de l'arête de coupe			
	Arêtes vives		Arêtes arrondies
	Arêtes avec listel		Arêtes arrondies avec listel
	Arêtes avec double listel		Arêtes arrondies avec double listel

9		9	
Direction d'avance			
R		N	
L			
10		10	
Désignation du brise-copeaux (géométrie)			



CCGT



	IC	D1	L	S
	(mm)	(mm)	(mm)	(mm)
0602	6.350	2.80	6.40	2.38
0602-SF3	6.350	2.80	6.40	2.58
0803-AL	7.940	3.40	8.10	3.43
0803-SF3	7.940	3.40	8.10	3.43
09T3	9.525	4.40	9.70	3.97
09T3-SF3	9.525	4.40	9.70	4.22
1204	12.700	5.50	12.90	4.76
1204-SF3	12.700	5.50	12.90	5.01

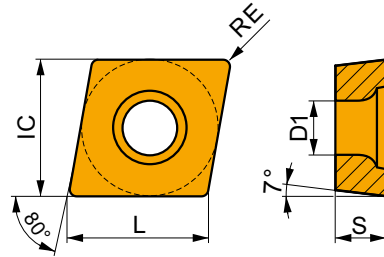

Adéquation et valeurs de départ pour la vitesse de coupe (vc), l'avance (f) et la profondeur de coupe (ap). Reportez-vous à notre application "Calculators" pour d'autres calculs.

Produit	RE	P			M			K			N			S			H		
		vc	f	ap	vc	f	ap	vc	f	ap	vc	f	ap	vc	f	ap	vc	f	ap
	(mm)	(m/min)	(mm/rev)	(mm)	(m/min)	(mm/rev)	(mm)	(m/min)	(mm/rev)	(mm)	(m/min)	(mm/rev)	(mm)	(m/min)	(mm/rev)	(mm)	(m/min)	(mm/rev)	(mm)



Géométrie AL avec une coupe très positive pour l'usinage de la finition fine à l'ébauche et pour les coupes continues à légèrement interrompues.

CCGT 060202F-AL	HF7	0.2	-	-	-	-	-	-	360	0.12	1.0	-	-	-	-	-	-	-	-
	T0315	0.2	-	-	-	-	-	-	360	0.12	1.0	-	-	-	-	-	-	-	-
CCGT 060204F-AL	HF7	0.4	-	-	-	-	-	-	300	0.24	1.0	-	-	-	-	-	-	-	-
	T0315	0.4	-	-	-	-	-	-	300	0.24	1.0	-	-	-	-	-	-	-	-
CCGT 080302F-AL	T0315	0.2	-	-	-	-	-	-	360	0.12	1.0	-	-	-	-	-	-	-	-
CCGT 080304F-AL	HF7	0.4	-	-	-	-	-	-	300	0.24	1.0	-	-	-	-	-	-	-	-
	T0315	0.4	-	-	-	-	-	-	300	0.24	1.0	-	-	-	-	-	-	-	-
CCGT 09T302F-AL	HF7	0.2	-	-	-	-	-	-	360	0.12	1.0	-	-	-	-	-	-	-	-
	T0315	0.2	-	-	-	-	-	-	360	0.12	1.0	-	-	-	-	-	-	-	-
CCGT 09T304F-AL	HF7	0.4	-	-	-	-	-	-	300	0.24	1.5	-	-	-	-	-	-	-	-
	T0315	0.4	-	-	-	-	-	-	300	0.24	1.5	-	-	-	-	-	-	-	-
CCGT 09T308F-AL	HF7	0.8	-	-	-	-	-	-	200	0.48	1.5	-	-	-	-	-	-	-	-
	T0315	0.8	-	-	-	-	-	-	200	0.48	1.5	-	-	-	-	-	-	-	-
CCGT 120404F-AL	HF7	0.4	-	-	-	-	-	-	300	0.24	2.4	-	-	-	-	-	-	-	-
	T0315	0.4	-	-	-	-	-	-	300	0.24	2.4	-	-	-	-	-	-	-	-
CCGT 120408F-AL	HF7	0.8	-	-	-	-	-	-	200	0.48	2.4	-	-	-	-	-	-	-	-
	T0315	0.8	-	-	-	-	-	-	200	0.48	2.4	-	-	-	-	-	-	-	-

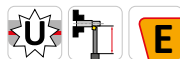
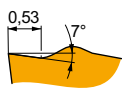

Géométrie FF2 avec une coupe positive pour l'usinage de la finition fine à la finition et pour les coupes continues à légèrement interrompues.

CCGT 09T302E-FF2	T7325	0.2	150	0.05	1.0	-	-	-	-	-	-	-	-	-	-	-	-	-	-
	T9325	0.2	150	0.05	1.0	-	-	-	115	0.05	1.0	-	-	-	-	-	-	-	-

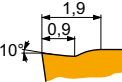

Géométrie NF1 avec une coupe positive pour l'usinage de la finition fine à moyen et pour les coupes continues.

CCGT 060204E-NF1	T6310	0.4	140	0.10	0.8	110	0.09	0.8	-	-	-	360	0.12	0.8	38	0.07	0.6	25	0.15	1.0
	T7325	0.4	140	0.10	0.8	110	0.09	0.8	-	-	-	-	-	-	45	0.07	0.6	-	-	-
CCGT 060208E-NF1	T6310	0.8	140	0.12	0.8	110	0.11	0.8	-	-	-	360	0.14	0.8	45	0.11	0.6	30	0.15	1.0
	T7325	0.8	140	0.12	0.8	110	0.11	0.8	-	-	-	-	-	-	45	0.11	0.6	-	-	-
CCGT 09T304E-NF1	T6310	0.4	140	0.10	1.2	110	0.09	1.2	-	-	-	360	0.12	1.2	38	0.07	1.0	25	0.15	1.0
	T7325	0.4	140	0.10	1.2	110	0.09	1.2	-	-	-	-	-	-	45	0.07	1.0	-	-	-
CCGT 09T308E-NF1	T6310	0.8	140	0.14	1.2	100	0.13	1.2	-	-	-	330	0.17	1.2	41	0.13	1.0	25	0.15	1.0
	T7325	0.8	140	0.14	1.2	100	0.13	1.2	-	-	-	-	-	-	45	0.13	1.0	-	-	-



Adéquation et valeurs de départ pour la vitesse de coupe (vc), l'avance (f) et la profondeur de coupe (ap). Reportez-vous à notre application "Calculators" pour d'autres calculs.

Produit	RE (mm)	P			M			K			N			S			H		
		vc (m/min)	f (mm/rev)	ap (mm)	vc (m/min)	f (mm/rev)	ap (mm)	vc (m/min)	f (mm/rev)	ap (mm)	vc (m/min)	f (mm/rev)	ap (mm)	vc (m/min)	f (mm/rev)	ap (mm)	vc (m/min)	f (mm/rev)	ap (mm)

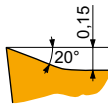

Géométrie SF3 avec une coupe fortement positive pour l'usinage de la finition fine à la finition et pour les coupes continues.

CCGT 060202E-SF3	H07	0.2	–	–	–	110	0.05	0.8	115	0.05	0.8	360	0.06	0.8	45	0.04	0.6	–	–	–
	T6310	0.2	150	0.05	0.8	110	0.05	0.8	115	0.05	0.8	360	0.06	0.8	45	0.04	0.6	30	0.15	1.0
	T8315	0.2	150	0.05	0.8	110	0.05	0.8	115	0.05	0.8	360	0.06	0.8	38	0.04	0.6	30	0.15	1.0
CCGT 060204E-SF3	H07	0.4	–	–	–	95	0.09	0.8	115	0.10	0.8	360	0.12	0.8	34	0.07	0.6	–	–	–
	T6310	0.4	140	0.10	0.8	110	0.09	0.8	115	0.10	0.8	360	0.12	0.8	38	0.07	0.6	26	0.15	1.0
	T8315	0.4	140	0.10	0.8	110	0.09	0.8	115	0.10	0.8	360	0.12	0.8	34	0.07	0.6	26	0.15	1.0
CCGT 080302E-SF3	T6310	0.2	150	0.05	0.8	110	0.05	0.8	115	0.05	0.8	360	0.06	0.8	45	0.04	0.6	30	0.15	1.0
	T8315	0.2	150	0.05	0.8	110	0.05	0.8	115	0.05	0.8	360	0.06	0.8	38	0.04	0.6	30	0.15	1.0
CCGT 080304E-SF3	H07	0.4	–	–	–	95	0.09	1.0	115	0.10	1.0	360	0.12	1.0	34	0.07	0.8	–	–	–
	T6310	0.4	140	0.10	1.0	110	0.09	1.0	115	0.10	1.0	360	0.12	1.0	38	0.07	0.8	26	0.15	1.0
	T8315	0.4	140	0.10	1.0	110	0.09	1.0	115	0.10	1.0	360	0.12	1.0	34	0.07	0.8	26	0.15	1.0
CCGT 09T302E-SF3	H07	0.2	–	–	–	110	0.05	0.8	115	0.05	0.8	360	0.06	0.8	45	0.04	0.6	–	–	–
	T6310	0.2	150	0.05	0.8	110	0.05	0.8	115	0.05	0.8	360	0.06	0.8	45	0.04	0.6	30	0.15	1.0
	T8315	0.2	150	0.05	0.8	110	0.05	0.8	115	0.05	0.8	360	0.06	0.8	38	0.04	0.6	30	0.15	1.0
CCGT 09T304E-SF3	H07	0.4	–	–	–	95	0.09	1.0	115	0.10	1.0	360	0.12	1.0	34	0.07	0.8	–	–	–
	T6310	0.4	140	0.10	1.0	110	0.09	1.0	115	0.10	1.0	360	0.12	1.0	38	0.07	0.8	26	0.15	1.0
	T8315	0.4	140	0.10	1.0	110	0.09	1.0	115	0.10	1.0	360	0.12	1.0	34	0.07	0.8	26	0.15	1.0
CCGT 09T308E-SF3	H07	0.8	–	–	–	110	0.09	1.0	115	0.10	1.0	360	0.12	1.0	41	0.08	0.8	–	–	–
	T6310	0.8	140	0.10	1.0	110	0.09	1.0	115	0.10	1.0	360	0.12	1.0	45	0.08	0.8	30	0.15	1.0
	T8315	0.8	140	0.10	1.0	110	0.09	1.0	115	0.10	1.0	360	0.12	1.0	41	0.08	0.8	34	0.15	1.0
CCGT 120408E-SF3	H07	0.8	–	–	–	105	0.12	1.0	110	0.12	1.0	360	0.14	1.0	38	0.11	0.8	–	–	–
	T6310	0.8	140	0.12	1.0	110	0.12	1.0	110	0.12	1.0	360	0.14	1.0	45	0.11	0.8	30	0.15	1.0
	T8315	0.8	140	0.12	1.0	110	0.12	1.0	110	0.12	1.0	360	0.14	1.0	38	0.11	0.8	30	0.15	1.0

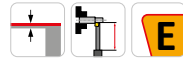
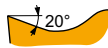

Géométrie EL-SI avec coupe positive à gauche pour l'usinage de finition fine et pour les coupes continues.

CCGT 060202EL-SI	T8330	0.2	140	0.10	0.8	110	0.09	0.8	115	0.10	0.8	–	–	–	38	0.08	0.6	–	–	–
	T8430	0.2	140	0.10	0.8	110	0.09	0.8	115	0.10	0.8	–	–	–	38	0.08	0.6	–	–	–
CCGT 060204EL-SI	T8315	0.4	140	0.12	0.8	110	0.11	0.8	110	0.12	0.8	–	–	–	41	0.10	0.6	–	–	–
	T8330	0.4	140	0.12	0.8	110	0.11	0.8	110	0.12	0.8	–	–	–	38	0.10	0.6	–	–	–
CCGT 09T304EL-SI	T8315	0.4	130	0.17	0.8	100	0.15	0.8	105	0.17	0.8	–	–	–	38	0.15	0.6	–	–	–
	T8330	0.4	130	0.17	0.8	100	0.15	0.8	105	0.17	0.8	–	–	–	34	0.15	0.6	–	–	–
CCGT 120408EL-SI	T8330	0.8	130	0.23	1.0	95	0.21	1.0	95	0.23	1.0	–	–	–	38	0.21	0.8	–	–	–
	T8430	0.8	130	0.24	1.0	95	0.22	1.0	95	0.24	1.0	–	–	–	34	0.22	0.8	–	–	–



CCGW CBN

PRAMET

	IC (mm)	D1 (mm)	L (mm)	S (mm)
0602	6.350	2.80	6.50	2.38
09T3	9.525	4.50	9.70	3.97

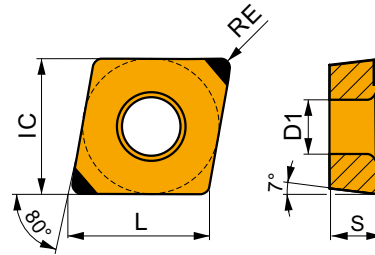

Adéquation et valeurs de départ pour la vitesse de coupe (vc), l'avance (f) et la profondeur de coupe (ap). Reportez-vous à notre application "Calculators" pour d'autres calculs.

Produit	RE (mm)	P			M			K			N			S			H		
		vc (m/min)	f (mm/rev)	ap (mm)	vc (m/min)	f (mm/rev)	ap (mm)	vc (m/min)	f (mm/rev)	ap (mm)	vc (m/min)	f (mm/rev)	ap (mm)	vc (m/min)	f (mm/rev)	ap (mm)	vc (m/min)	f (mm/rev)	ap (mm)

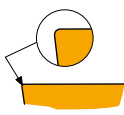

Pour l'usinage de finition.

CCGW 060204E-B	TB310	0.4	-	-	-	-	-	-	115	0.10	0.4	-	-	-	90	0.07	0.3	70	0.15	1.0
CCGW 09T304E-B	TB310	0.4	-	-	-	-	-	-	115	0.10	0.4	-	-	-	90	0.07	0.3	70	0.15	1.0

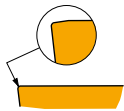

Pour l'usinage de finition.

CCGW 060204S01020B	TB310	0.4	-	-	-	-	-	-	115	0.10	0.4	-	-	-	90	0.07	0.3	70	0.15	1.0
CCGW 09T304S01020B	TB310	0.4	-	-	-	-	-	-	115	0.10	0.4	-	-	-	90	0.07	0.3	70	0.15	1.0

CCMT

PRAMET

	IC (mm)	D1 (mm)	L (mm)	S (mm)
0602	6.350	2.80	6.40	2.38
0803	7.940	3.40	8.10	3.18
09T3	9.525	4.40	9.70	3.97
1204	12.700	5.50	12.90	4.76

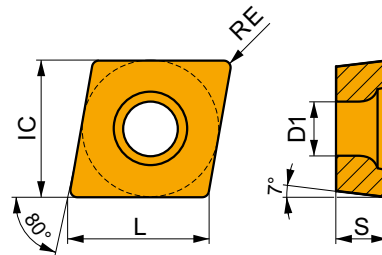

Adéquation et valeurs de départ pour la vitesse de coupe (vc), l'avance (f) et la profondeur de coupe (ap). Reportez-vous à notre application "Calculators" pour d'autres calculs.

Produit	RE (mm)	P			M			K			N			S			H		
		vc (m/min)	f (mm/rev)	ap (mm)	vc (m/min)	f (mm/rev)	ap (mm)	vc (m/min)	f (mm/rev)	ap (mm)	vc (m/min)	f (mm/rev)	ap (mm)	vc (m/min)	f (mm/rev)	ap (mm)	vc (m/min)	f (mm/rev)	ap (mm)

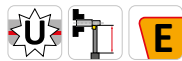
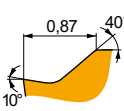

Géométrie FF avec une coupe positive pour l'usinage de finition fine et pour les coupes continues à légèrement interrompues.

CCMT 060202E-FF	T8330	0.2	140	0.10	1.0	110	0.09	1.0	-	-	-	-	-	-	-	-	-	-	-	-
	T8430	0.2	140	0.10	1.0	110	0.09	1.0	-	-	-	-	-	-	-	-	-	-	-	-
CCMT 060204E-FF	T8330	0.4	140	0.12	1.0	110	0.11	1.0	-	-	-	-	-	-	-	-	-	-	-	-
	T8430	0.4	140	0.12	1.0	110	0.11	1.0	-	-	-	-	-	-	-	-	-	-	-	-
CCMT 09T304E-FF	T8330	0.4	140	0.12	1.2	110	0.11	1.2	-	-	-	-	-	-	-	-	-	-	-	-
	T8430	0.4	140	0.12	1.2	110	0.11	1.2	-	-	-	-	-	-	-	-	-	-	-	-



Adéquation et valeurs de départ pour la vitesse de coupe (vc), l'avance (f) et la profondeur de coupe (ap). Reportez-vous à notre application "Calculators" pour d'autres calculs.

Produit	RE (mm)	P			M			K			N			S			H		
		vc (m/min)	f (mm/rev)	ap (mm)	vc (m/min)	f (mm/rev)	ap (mm)	vc (m/min)	f (mm/rev)	ap (mm)	vc (m/min)	f (mm/rev)	ap (mm)	vc (m/min)	f (mm/rev)	ap (mm)	vc (m/min)	f (mm/rev)	ap (mm)

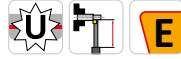
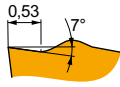

Géométrie FF2 avec une coupe positive pour l'usinage de la finition fine à la finition et pour les coupes continues à légèrement interrompues.

CCMT 060202E-FF2	T8330	0.2	150	0.05	0.8	-	-	-	115	0.05	0.8	-	-	-	-	-	-	-
	T8430	0.2	150	0.05	0.8	-	-	-	115	0.05	0.8	-	-	-	-	-	-	-
	T9325	0.2	150	0.05	0.8	-	-	-	115	0.05	0.8	-	-	-	-	-	-	-
	TT010	0.2	150	0.05	0.5	-	-	-	-	-	-	-	-	-	-	-	-	-
CCMT 060204E-FF2	T8330	0.4	140	0.12	1.0	-	-	-	110	0.12	1.0	-	-	-	-	-	-	-
	T8430	0.4	140	0.12	1.0	-	-	-	110	0.12	1.0	-	-	-	-	-	-	-
	T9325	0.4	140	0.12	1.0	-	-	-	110	0.12	1.0	-	-	-	-	-	-	-
	TT010	0.4	140	0.12	0.5	-	-	-	-	-	-	-	-	-	-	-	-	-
CCMT 080302E-FF2	T8330	0.2	150	0.05	0.8	-	-	-	115	0.05	0.8	-	-	-	-	-	-	-
	T8430	0.2	150	0.05	0.8	-	-	-	115	0.05	0.8	-	-	-	-	-	-	-
	T9325	0.2	150	0.05	0.8	-	-	-	115	0.05	0.8	-	-	-	-	-	-	-
	TT010	0.2	150	0.05	0.5	-	-	-	-	-	-	-	-	-	-	-	-	-
CCMT 080304E-FF2	T8330	0.4	140	0.12	1.0	-	-	-	110	0.12	1.0	-	-	-	-	-	-	-
	T8430	0.4	140	0.12	1.0	-	-	-	110	0.12	1.0	-	-	-	-	-	-	-
	T9325	0.4	140	0.12	1.0	-	-	-	110	0.12	1.0	-	-	-	-	-	-	-
	TT010	0.4	150	0.06	0.5	-	-	-	-	-	-	-	-	-	-	-	-	-
CCMT 080308E-FF2	T8330	0.8	130	0.17	1.0	-	-	-	105	0.17	1.0	-	-	-	-	-	-	-
	T8430	0.8	130	0.17	1.0	-	-	-	105	0.17	1.0	-	-	-	-	-	-	-
	T9325	0.8	130	0.17	1.0	-	-	-	105	0.17	1.0	-	-	-	-	-	-	-
CCMT 09T304E-FF2	T8330	0.4	140	0.12	1.2	-	-	-	110	0.12	1.2	-	-	-	-	-	-	-
	T8430	0.4	140	0.12	1.2	-	-	-	110	0.12	1.2	-	-	-	-	-	-	-
	T9325	0.4	140	0.12	1.2	-	-	-	110	0.12	1.2	-	-	-	-	-	-	-
	TT010	0.4	150	0.06	0.5	-	-	-	-	-	-	-	-	-	-	-	-	-
CCMT 09T308E-FF2	T8330	0.8	130	0.17	1.2	-	-	-	105	0.17	1.2	-	-	-	-	-	-	-
	T8430	0.8	130	0.17	1.2	-	-	-	105	0.17	1.2	-	-	-	-	-	-	-
	T9325	0.8	130	0.17	1.2	-	-	-	105	0.17	1.2	-	-	-	-	-	-	-
	TT010	0.8	140	0.10	0.8	-	-	-	-	-	-	-	-	-	-	-	-	-

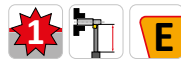

Géométrie FM pour l'usinage de la finition à la semi-ébauche et pour les coupes continues à légèrement interrompues.

CCMT 060202E-FM	T8330	0.2	140	0.10	1.0	110	0.09	1.0	115	0.10	1.0	360	0.12	1.0	-	-	-	-
	T8430	0.2	140	0.10	1.0	110	0.09	1.0	115	0.10	1.0	360	0.12	1.0	-	-	-	-
	T9325	0.2	140	0.10	1.0	110	0.09	1.0	115	0.10	1.0	-	-	-	-	-	-	-
CCMT 060204E-FM	T8330	0.4	140	0.15	1.0	100	0.14	1.0	110	0.15	1.0	330	0.18	1.0	-	-	-	-
	T8430	0.4	140	0.15	1.0	100	0.14	1.0	110	0.15	1.0	330	0.18	1.0	-	-	-	-
	T9325	0.4	140	0.15	1.0	100	0.15	1.0	110	0.15	1.0	-	-	-	-	-	-	-
CCMT 060208E-FM	T8330	0.8	130	0.20	1.0	100	0.18	1.0	100	0.20	1.0	300	0.24	1.0	-	-	-	-
	T8430	0.8	130	0.20	1.0	100	0.18	1.0	100	0.20	1.0	300	0.24	1.0	-	-	-	-
	T9325	0.8	130	0.20	1.0	100	0.18	1.0	100	0.20	1.0	-	-	-	-	-	-	-
CCMT 09T302E-FM	T8330	0.2	140	0.10	1.2	105	0.09	1.2	115	0.10	1.2	360	0.12	1.2	-	-	-	-
	T8430	0.2	140	0.10	1.2	110	0.09	1.2	115	0.10	1.2	360	0.12	1.2	-	-	-	-
	T9325	0.2	140	0.10	1.2	110	0.09	1.2	115	0.10	1.2	-	-	-	-	-	-	-
CCMT 09T304E-FM	T8330	0.4	140	0.15	1.2	100	0.14	1.2	110	0.15	1.2	330	0.18	1.2	-	-	-	-
	T8430	0.4	140	0.15	1.2	100	0.14	1.2	110	0.15	1.2	330	0.18	1.2	-	-	-	-
	T9325	0.4	140	0.15	1.2	100	0.15	1.2	110	0.15	1.2	-	-	-	-	-	-	-
CCMT 09T308E-FM	T8330	0.8	130	0.20	1.2	100	0.18	1.2	100	0.20	1.2	300	0.24	1.2	-	-	-	-
	T8430	0.8	130	0.20	1.2	100	0.18	1.2	100	0.20	1.2	300	0.24	1.2	-	-	-	-
	T9325	0.8	130	0.20	1.2	100	0.18	1.2	100	0.20	1.2	-	-	-	-	-	-	-
CCMT 120404E-FM	T8330	0.4	140	0.15	1.7	95	0.14	1.7	110	0.15	1.7	330	0.18	1.7	-	-	-	-
	T8430	0.4	140	0.15	1.7	100	0.14	1.7	110	0.15	1.7	330	0.18	1.7	-	-	-	-
	T9325	0.4	140	0.15	1.7	100	0.15	1.7	110	0.15	1.7	-	-	-	-	-	-	-
CCMT 120408E-FM	T8330	0.8	130	0.20	1.7	100	0.18	1.7	100	0.20	1.7	300	0.24	1.7	-	-	-	-
	T8430	0.8	130	0.20	1.7	100	0.18	1.7	100	0.20	1.7	300	0.24	1.7	-	-	-	-
	T9325	0.8	130	0.20	1.7	100	0.18	1.7	100	0.20	1.7	-	-	-	-	-	-	-



Adéquation et valeurs de départ pour la vitesse de coupe (vc), l'avance (f) et la profondeur de coupe (ap). Reportez-vous à notre application "Calculators" pour d'autres calculs.

Produit	RE (mm)	P			M			K			N			S			H		
		vc (m/min)	f (mm/rev)	ap (mm)	vc (m/min)	f (mm/rev)	ap (mm)	vc (m/min)	f (mm/rev)	ap (mm)	vc (m/min)	f (mm/rev)	ap (mm)	vc (m/min)	f (mm/rev)	ap (mm)	vc (m/min)	f (mm/rev)	ap (mm)

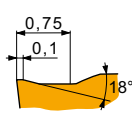

Géométrie FM2 pour l'usinage de la finition à moyen et pour des coupes continues à interrompues.

CCMT 080304E-FM2	T8330	0.4	140	0.12	1.0	95	0.11	1.0	110	0.12	1.0	-	-	-	-	-	-	-
	T8430	0.4	140	0.12	1.0	105	0.11	1.0	110	0.12	1.0	-	-	-	-	-	-	-
	T9325	0.4	140	0.12	1.0	110	0.11	1.0	110	0.12	1.0	-	-	-	-	-	-	-
CCMT 080308E-FM2	T8330	0.8	130	0.17	1.0	100	0.15	1.0	105	0.17	1.0	-	-	-	-	-	-	-
	T8430	0.8	130	0.17	1.0	100	0.15	1.0	105	0.17	1.0	-	-	-	-	-	-	-
	T9325	0.8	130	0.17	1.0	100	0.15	1.0	105	0.17	1.0	-	-	-	-	-	-	-
CCMT 09T304E-FM2	T8330	0.4	140	0.12	1.0	95	0.11	1.0	110	0.12	1.0	-	-	-	-	-	-	-
	T8430	0.4	140	0.12	1.0	105	0.11	1.0	110	0.12	1.0	-	-	-	-	-	-	-
	T9325	0.4	140	0.12	1.0	110	0.11	1.0	110	0.12	1.0	-	-	-	-	-	-	-
CCMT 09T308E-FM2	T8330	0.8	130	0.17	1.0	100	0.15	1.0	105	0.17	1.0	-	-	-	-	-	-	-
	T8430	0.8	130	0.17	1.0	100	0.15	1.0	105	0.17	1.0	-	-	-	-	-	-	-
	T9325	0.8	130	0.17	1.0	100	0.15	1.0	105	0.17	1.0	-	-	-	-	-	-	-
CCMT 120408E-FM2	T8330	0.8	130	0.20	1.5	95	0.18	1.5	100	0.20	1.5	-	-	-	-	-	-	-
	T8430	0.8	130	0.20	1.5	95	0.18	1.5	100	0.20	1.5	-	-	-	-	-	-	-
	T9325	0.8	130	0.20	1.5	100	0.18	1.5	100	0.20	1.5	-	-	-	-	-	-	-

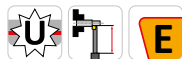

Géométrie NF2 avec une coupe positive pour l'usinage de la finition fine à la semi-ébauche et pour les coupes continues.

CCMT 060202E-NF2	T6310	0.2	140	0.10	0.8	110	0.09	0.8	115	0.10	0.8	360	0.12	0.8	38	0.08	0.6	-	-	-
	T9325	0.2	140	0.10	0.8	110	0.09	0.8	115	0.10	0.8	-	-	-	41	0.08	0.6	-	-	-
CCMT 060204E-NF2	H07	0.4	-	-	-	85	0.11	0.8	110	0.12	0.8	360	0.14	0.8	34	0.11	0.6	-	-	-
	T6310	0.4	140	0.12	0.8	110	0.11	0.8	110	0.12	0.8	360	0.14	0.8	38	0.11	0.6	-	-	-
CCMT 080304E-NF2	T9325	0.4	140	0.12	1.0	110	0.11	1.0	110	0.12	1.0	-	-	-	41	0.11	0.8	-	-	-
	T9325	0.8	130	0.17	1.0	100	0.15	1.0	105	0.17	1.0	-	-	-	41	0.14	0.8	-	-	-
CCMT 09T304E-NF2	H07	0.4	-	-	-	85	0.11	1.2	110	0.12	1.2	360	0.14	1.2	30	0.11	1.0	-	-	-
	T6310	0.4	140	0.12	1.2	110	0.11	1.2	110	0.12	1.2	360	0.14	1.2	34	0.11	1.0	-	-	-
	T9325	0.4	140	0.12	1.2	110	0.11	1.2	110	0.12	1.2	-	-	-	41	0.11	1.0	-	-	-
CCMT 09T308E-NF2	T6310	0.8	140	0.14	1.2	100	0.13	1.2	110	0.14	1.2	330	0.17	1.2	41	0.13	1.0	-	-	-
	T9325	0.8	140	0.14	1.2	100	0.13	1.2	110	0.14	1.2	-	-	-	45	0.13	1.0	-	-	-

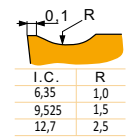

Géométrie RF pour l'usinage de la semi-ébauche à l'ébauche et pour les coupes continues à interrompues.

CCMT 060202E-RF	T7335	0.2	140	0.15	1.0	100	0.14	1.0	-	-	-	-	-	-	-	-	-	-	-	
CCMT 060204E-RF	T5315	0.4	140	0.15	1.0	-	-	-	110	0.15	1.0	-	-	-	-	-	-	35	0.15	1.0
	T7335	0.4	140	0.15	1.0	100	0.15	1.0	-	-	-	-	-	-	-	-	-	-	-	
CCMT 09T304E-RF	T7335	0.4	130	0.20	1.5	100	0.18	1.5	-	-	-	-	-	-	-	-	-	-	-	
CCMT 09T308E-RF	T5315	0.8	130	0.20	1.5	-	-	-	100	0.20	1.5	-	-	-	-	-	-	35	0.15	1.0
	T7335	0.8	130	0.20	1.5	100	0.18	1.5	-	-	-	-	-	-	-	-	-	-	-	
CCMT 120408E-RF	T5315	0.8	130	0.22	2.2	-	-	-	100	0.22	2.2	-	-	-	-	-	-	35	0.15	1.0
	T7335	0.8	130	0.22	2.2	95	0.22	2.2	-	-	-	-	-	-	-	-	-	-	-	

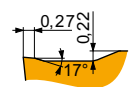
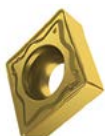

Géométrie RM pour l'usinage de la semi-ébauche à l'ébauche et pour les coupes continues à interrompues.

CCMT 09T304E-RM	T8330	0.4	120	0.27	2.2	80	0.24	2.2	95	0.27	2.2	-	-	-	26	0.19	1.8	20	0.15	1.0
	T8430	0.4	120	0.27	2.2	75	0.24	2.2	95	0.27	2.2	-	-	-	23	0.19	1.8	19	0.15	1.0
	T9325	0.4	120	0.27	2.2	95	0.24	2.2	95	0.27	2.2	-	-	-	30	0.19	1.8	-	-	-
CCMT 09T308E-RM	T8330	0.8	120	0.30	2.2	90	0.27	2.2	90	0.30	2.2	-	-	-	30	0.24	1.8	23	0.15	1.0
	T8430	0.8	120	0.30	2.2	90	0.27	2.2	90	0.30	2.2	-	-	-	26	0.24	1.8	23	0.15	1.0
	T9325	0.8	120	0.30	2.2	90	0.27	2.2	90	0.30	2.2	-	-	-	34	0.24	1.8	-	-	-



Adéquation et valeurs de départ pour la vitesse de coupe (vc), l'avance (f) et la profondeur de coupe (ap). Reportez-vous à notre application "Calculators" pour d'autres calculs.

Produit	RE (mm)	P			M			K			N			S			H		
		vc (m/min)	f (mm/rev)	ap (mm)	vc (m/min)	f (mm/rev)	ap (mm)	vc (m/min)	f (mm/rev)	ap (mm)	vc (m/min)	f (mm/rev)	ap (mm)	vc (m/min)	f (mm/rev)	ap (mm)	vc (m/min)	f (mm/rev)	ap (mm)

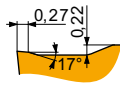
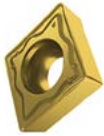

Géométrie RM pour l'usinage de la semi-ébauche à l'ébauche et pour les coupes continues à interrompues.

CCMT 120408E-RM	T8330	0.8	■	120	0.30	2.7	■	90	0.27	2.7	■	90	0.30	2.7	■	30	0.24	2.2	■	23	0.15	1.0
	T8430	0.8	■	120	0.30	2.7	■	90	0.27	2.7	■	90	0.30	2.7	■	26	0.24	2.2	■	23	0.15	1.0
	T9325	0.8	■	120	0.30	2.7	■	90	0.27	2.7	■	90	0.30	2.7	■	34	0.24	2.2	■	-	-	-

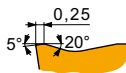

Géométrie RM3 pour l'usinage de la semi-ébauche à l'ébauche et pour les coupes continues à interrompues.

CCMT 120404E-RM3	T9325	0.4	■	120	0.25	2.5	■	95	0.25	2.5	■	95	0.25	2.5	■	-	-	-	■	-	-	-
CCMT 120408E-RM3	T6310	0.8	■	120	0.27	2.5	■	90	0.27	2.5	■	95	0.27	2.5	■	-	-	-	■	19	0.15	1.0
	T9325	0.8	■	120	0.27	2.5	■	90	0.27	2.5	■	95	0.27	2.5	■	-	-	-	■	-	-	-

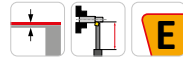
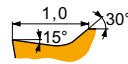

Géométrie UR pour l'usinage de la finition fine à la finition et pour les coupes continues à légèrement interrompues.

CCMT 060202E-UR	T8330	0.2	■	140	0.10	0.8	■	95	0.09	0.8	■	115	0.10	0.8	■	-	-	-	■	-	-	-
	TT310	0.2	■	140	0.10	0.5	■	110	0.09	0.5	■	-	-	-	■	-	-	-	■	-	-	-
CCMT 060204E-UR	T8330	0.4	■	140	0.15	1.0	■	90	0.14	1.0	■	110	0.15	1.0	■	-	-	-	■	-	-	-
	TT310	0.4	■	140	0.15	0.5	■	100	0.14	0.5	■	-	-	-	■	-	-	-	■	-	-	-
CCMT 060208E-UR	T8330	0.8	■	130	0.20	1.0	■	95	0.18	1.0	■	100	0.20	1.0	■	-	-	-	■	-	-	-
CCMT 09T302E-UR	TT310	0.2	■	140	0.10	1.0	■	110	0.09	1.0	■	-	-	-	■	-	-	-	■	-	-	-
CCMT 09T304E-UR	T8330	0.4	■	140	0.15	1.2	■	90	0.14	1.2	■	110	0.15	1.2	■	-	-	-	■	-	-	-
	TT310	0.4	■	140	0.15	1.2	■	100	0.14	1.2	■	-	-	-	■	-	-	-	■	-	-	-
CCMT 09T308E-UR	T8330	0.8	■	130	0.20	1.2	■	95	0.18	1.2	■	100	0.20	1.2	■	-	-	-	■	-	-	-
	TT310	0.8	■	130	0.20	1.2	■	100	0.18	1.2	■	-	-	-	■	-	-	-	■	-	-	-
CCMT 120404E-UR	T8330	0.4	■	140	0.15	1.7	■	80	0.14	1.7	■	110	0.15	1.7	■	-	-	-	■	-	-	-
CCMT 120408E-UR	T8330	0.8	■	130	0.20	1.7	■	90	0.18	1.7	■	100	0.20	1.7	■	-	-	-	■	-	-	-

CCMW



	IC (mm)	D1 (mm)	L (mm)	S (mm)
0602	6.350	2.80	6.40	2.38
09T3	9.525	4.40	9.70	3.97
1204	12.700	5.50	12.90	4.76

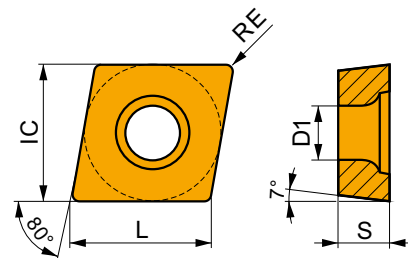

Adéquation et valeurs de départ pour la vitesse de coupe (vc), l'avance (f) et la profondeur de coupe (ap). Reportez-vous à notre application "Calculators" pour d'autres calculs.

Produit	RE (mm)	P			M			K			N			S			H		
		vc (m/min)	f (mm/rev)	ap (mm)	vc (m/min)	f (mm/rev)	ap (mm)	vc (m/min)	f (mm/rev)	ap (mm)	vc (m/min)	f (mm/rev)	ap (mm)	vc (m/min)	f (mm/rev)	ap (mm)	vc (m/min)	f (mm/rev)	ap (mm)

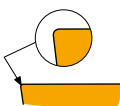

Pour l'usinage de la finition fine à la semi-ébauche et pour des coupes continues à légèrement interrompues.

CCMW 060204	T5315	0.4	■	-	-	-	■	-	-	-	■	115	0.10	2.0	■	-	-	-	■	30	0.15	1.0
CCMW 09T304	T5315	0.4	■	-	-	-	■	-	-	-	■	115	0.10	3.0	■	-	-	-	■	30	0.15	1.0
CCMW 09T308	T5315	0.8	■	-	-	-	■	-	-	-	■	100	0.20	3.0	■	-	-	-	■	26	0.15	1.0



Adéquation et valeurs de départ pour la vitesse de coupe (vc), l'avance (f) et la profondeur de coupe (ap). Reportez-vous à notre application "Calculators" pour d'autres calculs.

Produit	RE (mm)	P			M			K			N			S			H		
		vc (m/min)	f (mm/rev)	ap (mm)	vc (m/min)	f (mm/rev)	ap (mm)	vc (m/min)	f (mm/rev)	ap (mm)	vc (m/min)	f (mm/rev)	ap (mm)	vc (m/min)	f (mm/rev)	ap (mm)	vc (m/min)	f (mm/rev)	ap (mm)

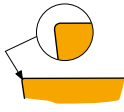

Pour l'usinage de la finition fine à la semi-ébauche et pour des coupes continues à légèrement interrompues.

CCMW 120404	T5315	0.4	-	-	-	-	-	-	115	0.10	4.0	-	-	-	-	-	-	26	0.15	1.0
CCMW 120408	T5315	0.8	-	-	-	-	-	-	100	0.20	4.0	-	-	-	-	-	-	26	0.15	1.0

CNGA CBN

PRAMET

	IC (mm)	D1 (mm)	L (mm)	S (mm)
1204	12.700	5.16	12.90	4.76

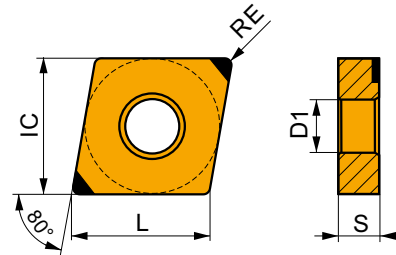

Adéquation et valeurs de départ pour la vitesse de coupe (vc), l'avance (f) et la profondeur de coupe (ap). Reportez-vous à notre application "Calculators" pour d'autres calculs.

Produit	RE (mm)	P			M			K			N			S			H		
		vc (m/min)	f (mm/rev)	ap (mm)	vc (m/min)	f (mm/rev)	ap (mm)	vc (m/min)	f (mm/rev)	ap (mm)	vc (m/min)	f (mm/rev)	ap (mm)	vc (m/min)	f (mm/rev)	ap (mm)	vc (m/min)	f (mm/rev)	ap (mm)

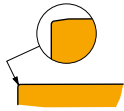

Pour l'usinage de finition et pour les coupes continues.

CNGA 120404S01020B	TB310	0.4	-	-	-	-	-	115	0.10	0.4	-	-	-	100	0.07	0.3	80	0.15	1.0
CNGA 120408S01020B	TB310	0.8	-	-	-	-	-	110	0.15	0.6	-	-	-	100	0.11	0.5	85	0.15	1.0



CNGG

	IC	D1	L	S
	(mm)	(mm)	(mm)	(mm)
1204	12.700	5.16	12.90	4.76

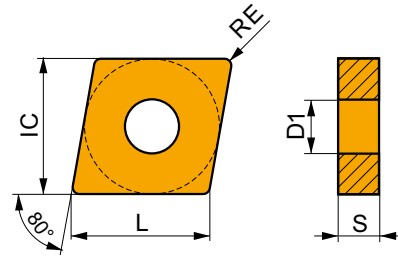

Adéquation et valeurs de départ pour la vitesse de coupe (vc), l'avance (f) et la profondeur de coupe (ap). Reportez-vous à notre application "Calculators" pour d'autres calculs.

Produit	RE	P			M			K			N			S			H		
		vc	f	ap	vc	f	ap	vc	f	ap	vc	f	ap	vc	f	ap	vc	f	ap
	(mm)	(m/min)	(mm/rev)	(mm)	(m/min)	(mm/rev)	(mm)	(m/min)	(mm/rev)	(mm)	(m/min)	(mm/rev)	(mm)	(m/min)	(mm/rev)	(mm)	(m/min)	(mm/rev)	(mm)

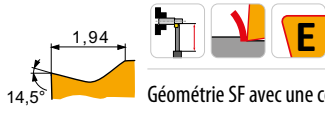

Géométrie SF avec une coupe positive pour l'usinage de finition des parois fines et pour les coupes continues.

CNGG 120402E-SF	H07	0.2	–	–	–	105	0.09	1.0	115	0.10	1.0	360	0.12	1.0	38	0.08	0.8	–	–	–
	T6310	0.2	140	0.10	1.0	110	0.09	1.0	115	0.10	1.0	360	0.12	1.0	41	0.08	0.8	26	0.15	1.0
	T8330	0.2	140	0.10	1.0	110	0.09	1.0	115	0.10	1.0	360	0.12	1.0	34	0.08	0.8	26	0.15	1.0
	T8430	0.2	140	0.10	1.0	110	0.09	1.0	115	0.10	1.0	360	0.12	1.0	34	0.08	0.8	30	0.15	1.0

CNMA

	IC	D1	L	S
	(mm)	(mm)	(mm)	(mm)
1204	12.700	5.16	12.90	4.76

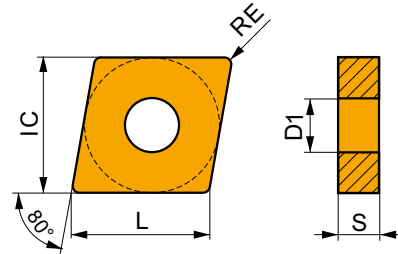

Adéquation et valeurs de départ pour la vitesse de coupe (vc), l'avance (f) et la profondeur de coupe (ap). Reportez-vous à notre application "Calculators" pour d'autres calculs.

Produit	RE	P			M			K			N			S			H		
		vc	f	ap	vc	f	ap	vc	f	ap	vc	f	ap	vc	f	ap	vc	f	ap
	(mm)	(m/min)	(mm/rev)	(mm)	(m/min)	(mm/rev)	(mm)	(m/min)	(mm/rev)	(mm)	(m/min)	(mm/rev)	(mm)	(m/min)	(mm/rev)	(mm)	(m/min)	(mm/rev)	(mm)

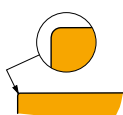

Pour l'usinage de la finition fine à la semi-ébauche et pour des coupes continues à légèrement interrompues.

CNMA 120404	T5315	0.4	–	–	–	–	–	–	115	0.10	4.0	–	–	–	–	–	–	30	0.15	1.0
CNMA 120408	T5315	0.8	–	–	–	–	–	–	100	0.20	4.0	–	–	–	–	–	–	30	0.15	1.0
CNMA 120412	T5315	1.2	–	–	–	–	–	–	90	0.30	4.0	–	–	–	–	–	–	25	0.15	1.0



CNMG

	IC	D1	L	S
	(mm)	(mm)	(mm)	(mm)
1204	12.700	5.16	12.90	4.76

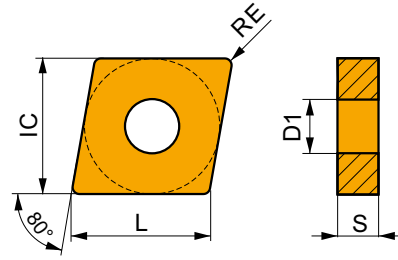

Adéquation et valeurs de départ pour la vitesse de coupe (vc), l'avance (f) et la profondeur de coupe (ap). Reportez-vous à notre application "Calculators" pour d'autres calculs.

Produit	RE	P			M			K			N			S			H		
		vc	f	ap	vc	f	ap	vc	f	ap	vc	f	ap	vc	f	ap	vc	f	ap
	(mm)	(m/min)	(mm/rev)	(mm)	(m/min)	(mm/rev)	(mm)	(m/min)	(mm/rev)	(mm)	(m/min)	(mm/rev)	(mm)	(m/min)	(mm/rev)	(mm)	(m/min)	(mm/rev)	(mm)

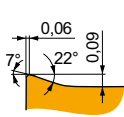
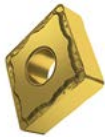

Géométrie FF avec une coupe fortement positive pour l'usinage de finition fine et pour les coupes continues à légèrement interrompues.

CNMG 120404E-FF	T7325	0.4	✓	140	0.12	1.0	■	110	0.11	1.0	—	—	—	—	—	—	—	—	—	—
	T8315	0.4	✓	140	0.12	1.0	■	110	0.11	1.0	✓	110	0.12	1.0	—	—	—	—	—	—
CNMG 120408E-FF	T7325	0.8	✓	140	0.15	1.0	■	100	0.14	1.0	—	—	—	—	—	—	—	—	—	—
	T8315	0.8	✓	140	0.15	1.0	■	100	0.14	1.0	✓	110	0.15	1.0	—	—	—	—	—	—

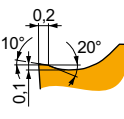

Géométrie FM avec une coupe positive pour l'usinage de la finition à la semi-ébauche et pour des coupes continues à légèrement interrompues.

CNMG 120404E-FM	T9325	0.4	■	130	0.20	2.1	✓	100	0.18	2.1	✓	100	0.20	2.1	—	—	—	✓	38	0.16	1.7	—	—	—
	TT310	0.4	■	130	0.20	2.1	✓	100	0.18	2.1	—	—	—	—	—	—	—	—	—	—	—	—	—	
CNMG 120408E-FM	T9325	0.8	■	130	0.20	2.1	✓	100	0.18	2.1	✓	100	0.20	2.1	—	—	—	✓	45	0.16	1.7	—	—	—
	TT310	0.8	■	130	0.20	2.1	✓	100	0.18	2.1	—	—	—	—	—	—	—	—	—	—	—	—	—	

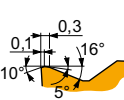

Géométrie M pour l'usinage de la finition à la semi-ébauche et pour les coupes continues à interrompues.

CNMG 120404E-M	T5315	0.4	✓	130	0.20	2.1	—	—	—	■	100	0.20	2.1	—	—	—	—	—	—	—	✓	35	0.15	1.0
	T9325	0.4	■	130	0.20	2.1	—	—	—	✓	100	0.20	2.1	—	—	—	—	—	—	—	—	—	—	—
CNMG 120408E-M	T5315	0.8	✓	120	0.32	2.1	—	—	—	■	90	0.32	2.1	—	—	—	—	—	—	—	✓	38	0.15	1.0
	T9325	0.8	■	120	0.32	2.1	—	—	—	✓	90	0.32	2.1	—	—	—	—	—	—	—	—	—	—	—

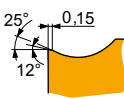

Géométrie NF avec une coupe fortement positive pour l'usinage de la finition fine à moyen et pour les coupes continues.

CNMG 120404E-NF	T7325	0.4	✓	130	0.18	1.7	■	100	0.16	1.7	—	—	—	—	—	—	—	✓	45	0.16	1.4	—	—	—	
	T8330	0.4	■	130	0.17	1.7	■	100	0.15	1.7	✓	105	0.17	1.7	✓	330	0.20	1.7	✓	34	0.14	1.4	—	—	—
	T8430	0.4	■	130	0.17	1.7	■	100	0.15	1.7	✓	105	0.17	1.7	✓	330	0.20	1.7	✓	30	0.14	1.4	—	—	—
CNMG 120408E-NF	T7325	0.8	✓	130	0.19	1.7	■	100	0.17	1.7	—	—	—	—	—	—	—	—	✓	45	0.15	1.4	—	—	—
	T8330	0.8	■	130	0.19	1.7	■	100	0.17	1.7	✓	100	0.19	1.7	✓	300	0.23	1.7	✓	38	0.15	1.4	—	—	—
	T8430	0.8	■	130	0.19	1.7	■	100	0.17	1.7	✓	100	0.19	1.7	✓	300	0.23	1.7	✓	34	0.15	1.4	—	—	—

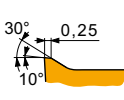

Géométrie NM avec une coupe fortement positive pour l'usinage de la finition fine, moyenne et jusqu'à l'ébauche, pour les coupes continues.

CNMG 120404E-NM	T7325	0.4	✓	130	0.20	2.1	■	100	0.18	2.1	—	—	—	—	—	—	—	—	—	—	✓	45	0.16	1.7	—	—	—
	T8330	0.4	■	130	0.20	2.1	■	100	0.18	2.1	—	—	—	✓	300	0.24	2.1	✓	30	0.16	1.7	—	—	—			
	T8430	0.4	■	130	0.20	2.1	■	100	0.18	2.1	—	—	—	✓	300	0.24	2.1	✓	30	0.16	1.7	—	—	—			



Adéquation et valeurs de départ pour la vitesse de coupe (vc), l'avance (f) et la profondeur de coupe (ap). Reportez-vous à notre application "Calculators" pour d'autres calculs.

Produit	RE (mm)	P			M			K			N			S			H		
		vc (m/min)	f (mm/rev)	ap (mm)	vc (m/min)	f (mm/rev)	ap (mm)	vc (m/min)	f (mm/rev)	ap (mm)	vc (m/min)	f (mm/rev)	ap (mm)	vc (m/min)	f (mm/rev)	ap (mm)	vc (m/min)	f (mm/rev)	ap (mm)

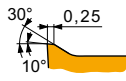

Géométrie NM avec une coupe fortement positive pour l'usinage de la finition fine, moyenne et jusqu'à l'ébauche, pour les coupes continues.

CNMG 120408E-NM	T7325	0.8	120	0.25	2.1	95	0.23	2.1	-	-	-	-	-	-	45	0.20	1.7	-	-	-
	T8330	0.8	120	0.25	2.1	95	0.23	2.1	-	-	-	270	0.30	2.1	34	0.20	1.7	-	-	-
	T8430	0.8	120	0.25	2.1	95	0.23	2.1	-	-	-	270	0.30	2.1	30	0.20	1.7	-	-	-

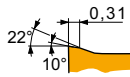

Géométrie NMR avec une coupe positive pour l'usinage moyen jusqu'à l'ébauche et pour les coupes continues.

CNMG 120404E-NMR	T7325	0.4	120	0.25	2.7	95	0.23	2.7	-	-	-	-	-	-	38	0.20	2.2	-	-	-
	T8330	0.4	120	0.25	2.0	80	0.23	2.0	-	-	-	-	-	-	26	0.20	1.6	-	-	-
	T8430	0.4	120	0.25	2.7	75	0.23	2.7	-	-	-	-	-	-	23	0.20	2.2	-	-	-
CNMG 120408E-NMR	T7325	0.8	120	0.35	2.7	90	0.32	2.7	-	-	-	-	-	-	41	0.25	2.2	-	-	-
	T8330	0.8	120	0.35	2.7	90	0.32	2.7	-	-	-	-	-	-	26	0.25	2.2	-	-	-
	T8430	0.8	120	0.35	2.7	80	0.32	2.7	-	-	-	-	-	-	23	0.25	2.2	-	-	-

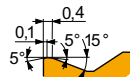

Géométrie R pour l'usinage de la semi-ébauche à l'ébauche et pour les coupes continues à interrompues.

CNMG 120408E-R	T5315	0.8	120	0.40	4.0	-	-	-	80	0.40	4.0	-	-	-	-	-	-	30	0.15	1.0
	T9325	0.8	120	0.40	4.0	-	-	-	80	0.40	4.0	-	-	-	-	-	-	-	-	-

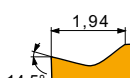

Géométrie SF avec une coupe positive pour l'usinage en finition des parois fines et pour les coupes continues.

CNMG 120404E-SF	H07	0.4	-	-	-	90	0.14	1.0	110	0.15	1.0	330	0.18	1.0	34	0.12	0.8	-	-	-
	T6310	0.4	140	0.15	1.0	100	0.14	1.0	110	0.15	1.0	330	0.18	1.0	38	0.12	0.8	26	0.15	1.0
CNMG 120408E-SF	H07	0.8	-	-	-	95	0.18	1.0	100	0.20	1.0	300	0.24	1.0	38	0.14	0.8	-	-	-
	T6310	0.8	130	0.20	1.0	100	0.18	1.0	100	0.20	1.0	300	0.24	1.0	45	0.14	0.8	30	0.15	1.0

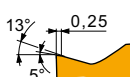

Géométrie SM avec une coupe positive pour l'usinage moyen et pour les coupes continues à interrompues.

CNMG 120404E-SM	T6310	0.4	130	0.22	2.0	95	0.20	2.0	100	0.22	2.0	300	0.26	2.0	34	0.20	1.6	23	0.15	1.0
	T7325	0.4	130	0.22	2.0	95	0.20	2.0	-	-	-	-	-	-	41	0.20	1.6	-	-	-
CNMG 120408E-SM	T6310	0.8	120	0.25	2.0	95	0.23	2.0	95	0.25	2.0	270	0.30	2.0	38	0.20	1.6	26	0.15	1.0
	T7325	0.8	120	0.25	2.0	95	0.23	2.0	-	-	-	-	-	-	45	0.20	1.6	-	-	-

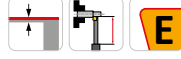
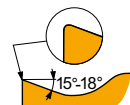

Géométrie EL-SI avec coupe positive à gauche pour l'usinage de la finition fine à la semi-ébauche et pour les coupes continues.

CNMG 120404EL-SI	T7325	0.4	130	0.20	1.7	100	0.18	1.7	-	-	-	-	-	-	45	0.18	1.4	-	-	-
	T8330	0.4	130	0.20	1.7	100	0.18	1.7	-	-	-	300	0.24	1.7	34	0.18	1.4	-	-	-
	T8430	0.4	130	0.20	1.7	100	0.18	1.7	-	-	-	300	0.24	1.7	34	0.18	1.4	-	-	-
CNMG 120408EL-SI	T7325	0.8	120	0.35	1.7	90	0.32	1.7	-	-	-	-	-	-	45	0.25	1.4	-	-	-
	T8330	0.8	120	0.35	1.7	90	0.32	1.7	-	-	-	220	0.42	1.7	34	0.25	1.4	-	-	-
	T8430	0.8	120	0.35	1.7	90	0.32	1.7	-	-	-	220	0.42	1.7	30	0.25	1.4	-	-	-



DCMT



	IC	D1	L	S
	(mm)	(mm)	(mm)	(mm)
11T3	9.525	4.40	11.60	3.97
1504	12.700	5.50	15.50	4.76

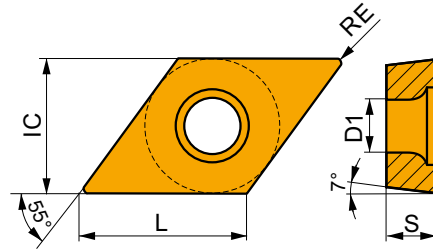

Adéquation et valeurs de départ pour la vitesse de coupe (vc), l'avance (f) et la profondeur de coupe (ap). Reportez-vous à notre application "Calculators" pour d'autres calculs.

Produit	RE	P			M			K			N			S			H		
		vc	f	ap	vc	f	ap	vc	f	ap	vc	f	ap	vc	f	ap	vc	f	ap
	(mm)	(m/min)	(mm/rev)	(mm)	(m/min)	(mm/rev)	(mm)	(m/min)	(mm/rev)	(mm)	(m/min)	(mm/rev)	(mm)	(m/min)	(mm/rev)	(mm)	(m/min)	(mm/rev)	(mm)

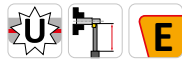
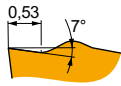

Géométrie FF2 avec une coupe positive pour l'usinage de la finition fine à la finition et pour les coupes continues à légèrement interrompues.

DCMT 11T308E-FF2	T7325	0.8	130	0.17	0.8	-	-	-	-	-	-	-	-	-	-	-	-	-	-
	T8330	0.8	130	0.17	0.8	-	-	-	105	0.17	0.8	-	-	-	-	-	-	-	-
	T8430	0.8	130	0.17	0.8	-	-	-	105	0.17	0.8	-	-	-	-	-	-	-	-

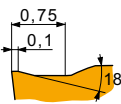

Géométrie FM2 pour l'usinage de la finition à moyen et pour des coupes continues à interrompues.

DCMT 150408E-FM2	T9325	0.8	130	0.20	1.5	100	0.18	1.5	100	0.20	1.5	-	-	-	-	-	-	-	-
	T9335	0.8	130	0.20	1.5	95	0.18	1.5	-	-	-	-	-	-	-	-	-	-	-

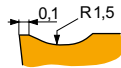

Géométrie RF pour l'usinage de la semi-ébauche à l'ébauche et pour les coupes continues à interrompues.

DCMT 11T308E-RF	T5315	0.8	130	0.20	0.8	-	-	-	100	0.20	0.8	-	-	-	-	-	-	30	0.15	1.0
	T7335	0.8	130	0.20	0.8	100	0.18	0.8	-	-	-	-	-	-	-	-	-	-	-	-



DCMW



	IC	D1	L	S
	(mm)	(mm)	(mm)	(mm)
11T3	9.525	4.40	11.60	3.97

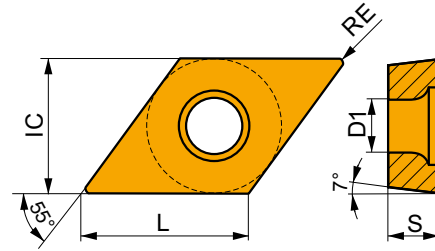

Adéquation et valeurs de départ pour la vitesse de coupe (vc), l'avance (f) et la profondeur de coupe (ap). Reportez-vous à notre application "Calculators" pour d'autres calculs.

Produit	RE (mm)	P			M			K			N			S			H		
		vc (m/min)	f (mm/rev)	ap (mm)	vc (m/min)	f (mm/rev)	ap (mm)	vc (m/min)	f (mm/rev)	ap (mm)	vc (m/min)	f (mm/rev)	ap (mm)	vc (m/min)	f (mm/rev)	ap (mm)	vc (m/min)	f (mm/rev)	ap (mm)

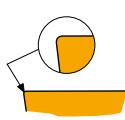

Pour l'usinage de la finition fine à la semi-ébauche et pour des coupes continues à légèrement interrompues.

DCMW 11T304	T5315	0.4	—	—	—	—	—	—	—	115	0.10	1.2	—	—	—	—	—	—	26	0.15	1.0
	T6310	0.4	—	—	—	—	—	—	—	80	0.10	1.2	—	—	—	—	—	—	15	0.15	1.0
DCMW 11T308	T5315	0.8	—	—	—	—	—	—	—	105	0.18	1.2	—	—	—	—	—	—	23	0.15	1.0
	T6310	0.8	—	—	—	—	—	—	—	80	0.18	1.2	—	—	—	—	—	—	15	0.15	1.0

DCMW PCD



	IC	D1	L	S
	(mm)	(mm)	(mm)	(mm)
11T3	9.525	4.40	11.60	3.97

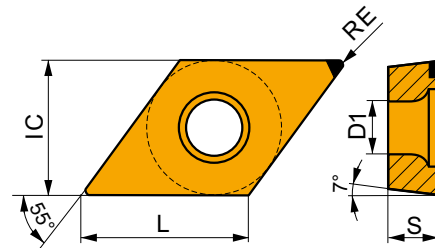

Adéquation et valeurs de départ pour la vitesse de coupe (vc), l'avance (f) et la profondeur de coupe (ap). Reportez-vous à notre application "Calculators" pour d'autres calculs.

Produit	RE (mm)	P			M			K			N			S			H		
		vc (m/min)	f (mm/rev)	ap (mm)	vc (m/min)	f (mm/rev)	ap (mm)	vc (m/min)	f (mm/rev)	ap (mm)	vc (m/min)	f (mm/rev)	ap (mm)	vc (m/min)	f (mm/rev)	ap (mm)	vc (m/min)	f (mm/rev)	ap (mm)

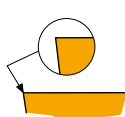
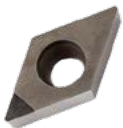

Pour l'usinage de finition, les vitesses élevées et les conditions d'usinage stables.

DCMW 11T304FN	PD1	0.4	—	—	—	—	—	—	—	360	0.12	0.5	—	—	—	—	—	—	—	—	—
DCMW 11T308FN	PD1	0.8	—	—	—	—	—	—	—	360	0.12	1.0	—	—	—	—	—	—	—	—	—



EPGX

	IC	D1	L	S
	(mm)	(mm)	(mm)	(mm)
0502	5.560	2.50	5.70	2.38

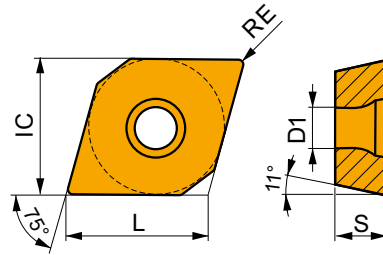

Adéquation et valeurs de départ pour la vitesse de coupe (vc), l'avance (f) et la profondeur de coupe (ap). Reportez-vous à notre application "Calculators" pour d'autres calculs.

Produit	RE	P			M			K			N			S			H		
		vc	f	ap	vc	f	ap	vc	f	ap	vc	f	ap	vc	f	ap	vc	f	ap
	(mm)	(m/min)	(mm/rev)	(mm)	(m/min)	(mm/rev)	(mm)	(m/min)	(mm/rev)	(mm)	(m/min)	(mm/rev)	(mm)	(m/min)	(mm/rev)	(mm)	(m/min)	(mm/rev)	(mm)

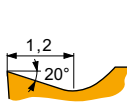

Géométrie FL-JZ avec coupe positive à gauche pour l'usinage de finition fine et pour les coupes continues.

EPGX 050202FL-JZ	TT010	0.2	150	0.06	0.5	110	0.05	0.5	-	-	-	-	-	-	-	-	-	-	-
------------------	-------	-----	-----	------	-----	-----	------	-----	---	---	---	---	---	---	---	---	---	---	---

EPMT

	IC	D1	L	S
	(mm)	(mm)	(mm)	(mm)
0502	5.560	2.50	5.70	2.38

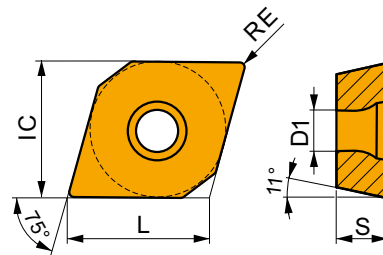

Adéquation et valeurs de départ pour la vitesse de coupe (vc), l'avance (f) et la profondeur de coupe (ap). Reportez-vous à notre application "Calculators" pour d'autres calculs.

Produit	RE	P			M			K			N			S			H		
		vc	f	ap	vc	f	ap	vc	f	ap	vc	f	ap	vc	f	ap	vc	f	ap
	(mm)	(m/min)	(mm/rev)	(mm)	(m/min)	(mm/rev)	(mm)	(m/min)	(mm/rev)	(mm)	(m/min)	(mm/rev)	(mm)	(m/min)	(mm/rev)	(mm)	(m/min)	(mm/rev)	(mm)

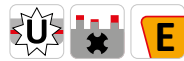

Géométrie NF2 avec une coupe positive pour l'usinage de la finition fine à la semi-ébauche et pour les coupes continues.

EPMT 050202E-NF2	H07	0.2	-	-	-	80	0.09	0.8	115	0.10	0.8	360	0.12	0.8	30	0.07	0.6	-	-	-
	T7325	0.2	150	0.07	0.8	110	0.06	0.8	-	-	-	-	-	-	45	0.06	0.6	-	-	-
	T7335	0.2	150	0.07	0.8	110	0.06	0.8	-	-	-	-	-	-	45	0.06	0.6	-	-	-
	T9315	0.2	150	0.05	0.8	-	-	-	115	0.05	0.8	-	-	-	-	-	-	-	-	-
	T9325	0.2	150	0.07	0.8	110	0.06	0.8	115	0.07	0.8	-	-	-	45	0.06	0.6	-	-	-
	T9335	0.2	140	0.10	0.8	110	0.09	0.8	-	-	-	-	-	-	34	0.07	0.6	-	-	-
	TT010	0.2	150	0.05	0.5	110	0.05	0.5	-	-	-	-	-	-	-	-	-	-	-	-



TCGT



	IC (mm)	D1 (mm)	L (mm)	S (mm)
06T1	3.970	2.20	6.90	1.98
0902	5.560	2.50	9.60	2.38
1102-SF3	6.350	2.80	11.00	2.58
16T3	9.525	4.40	16.50	3.97
16T3-SF3	9.525	4.40	16.50	4.22

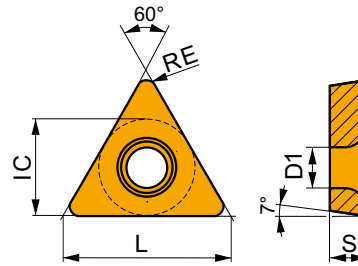

Adéquation et valeurs de départ pour la vitesse de coupe (vc), l'avance (f) et la profondeur de coupe (ap). Reportez-vous à notre application "Calculators" pour d'autres calculs.

Produit	RE (mm)	P			M			K			N			S			H		
		vc (m/min)	f (mm/rev)	ap (mm)	vc (m/min)	f (mm/rev)	ap (mm)	vc (m/min)	f (mm/rev)	ap (mm)	vc (m/min)	f (mm/rev)	ap (mm)	vc (m/min)	f (mm/rev)	ap (mm)	vc (m/min)	f (mm/rev)	ap (mm)



Géométrie AL avec une coupe très positive pour l'usinage de la finition fine à l'ébauche et pour les coupes continues à légèrement interrompues.

TCGT 090202F-AL	HF7	0.2	-	-	-	-	-	-	-	360	0.12	1.0	-	-	-	-	-	-
	T0315	0.2	-	-	-	-	-	-	-	360	0.12	1.0	-	-	-	-	-	-
TCGT 090204F-AL	HF7	0.4	-	-	-	-	-	-	-	300	0.24	1.0	-	-	-	-	-	-
	T0315	0.4	-	-	-	-	-	-	-	300	0.24	1.0	-	-	-	-	-	-
TCGT 16T304F-AL	HF7	0.4	-	-	-	-	-	-	-	300	0.24	2.4	-	-	-	-	-	-
	T0315	0.4	-	-	-	-	-	-	-	300	0.24	2.4	-	-	-	-	-	-
TCGT 16T308F-AL	HF7	0.8	-	-	-	-	-	-	-	200	0.48	2.4	-	-	-	-	-	-
	T0315	0.8	-	-	-	-	-	-	-	200	0.48	2.4	-	-	-	-	-	-

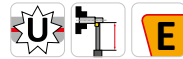
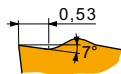

Géométrie FF2 avec une coupe positive pour l'usinage de la finition fine à la finition et pour les coupes continues à légèrement interrompues.

TCGT 06T102E-FF2	T8330	0.2	150	0.05	0.8	-	-	-	115	0.05	0.8	-	-	-	-	-	-	-
	T8430	0.2	150	0.05	0.8	-	-	-	115	0.05	0.8	-	-	-	-	-	-	-
	TT010	0.2	150	0.05	0.5	-	-	-	-	-	-	-	-	-	-	-	-	-
TCGT 090202E-FF2	TT010	0.2	150	0.05	0.5	-	-	-	-	-	-	-	-	-	-	-	-	-

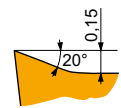

Géométrie SF3 avec une coupe fortement positive pour l'usinage de la finition fine à la finition et pour les coupes continues.

TCGT 110204E-SF3	H07	0.4	-	-	-	80	0.09	0.8	115	0.10	0.8	360	0.12	0.8	30	0.07	0.6	-	-	-
	T6310	0.4	140	0.10	0.8	110	0.09	0.8	115	0.10	0.8	360	0.12	0.8	34	0.07	0.6	23	0.15	1.0
TCGT 16T308E-SF3	H07	0.8	-	-	-	90	0.09	1.2	115	0.10	1.2	360	0.12	1.2	34	0.08	1.0	-	-	-
	T6310	0.8	140	0.10	1.2	110	0.09	1.2	115	0.10	1.2	360	0.12	1.2	38	0.08	1.0	26	0.15	1.0



TCMT

	IC	D1	L	S
	(mm)	(mm)	(mm)	(mm)
06T1	3.970	2.20	6.90	1.98
0902	5.560	2.50	9.60	2.38
16T3	9.525	4.40	16.50	3.97

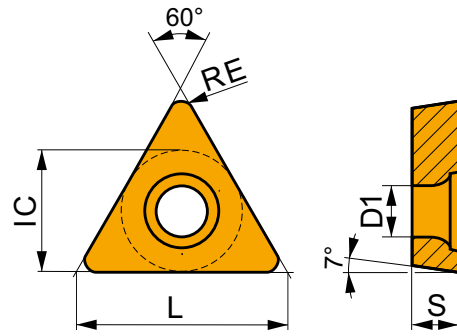

Adéquation et valeurs de départ pour la vitesse de coupe (vc), l'avance (f) et la profondeur de coupe (ap). Reportez-vous à notre application "Calculators" pour d'autres calculs.

Produit	RE	P			M			K			N			S			H		
		vc	f	ap	vc	f	ap	vc	f	ap	vc	f	ap	vc	f	ap	vc	f	ap
	(mm)	(m/min)	(mm/rev)	(mm)	(m/min)	(mm/rev)	(mm)	(m/min)	(mm/rev)	(mm)	(m/min)	(mm/rev)	(mm)	(m/min)	(mm/rev)	(mm)	(m/min)	(mm/rev)	(mm)

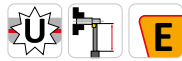
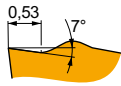

Géométrie FF2 avec une coupe positive pour l'usinage de la finition fine à la finition et pour les coupes continues à légèrement interrompues.

TCMT 06T102E-FF2	T8330	0.2	█	150	0.05	0.8	█	–	–	–	█	115	0.05	0.8	–	–	–	–	–	–
	T8430	0.2	█	150	0.05	0.8	█	–	–	–	█	115	0.05	0.8	–	–	–	–	–	–
	T9315	0.2	█	150	0.05	0.8	█	–	–	–	█	115	0.05	0.8	–	–	–	–	–	–
TCMT 06T104E-FF2	T8330	0.4	█	140	0.12	0.8	█	–	–	–	█	110	0.12	0.8	–	–	–	–	–	–
	T8430	0.4	█	140	0.12	0.8	█	–	–	–	█	110	0.12	0.8	–	–	–	–	–	–
	T9325	0.4	█	140	0.12	0.8	█	–	–	–	█	110	0.12	0.8	–	–	–	–	–	–
TCMT 090204E-FF2	T8330	0.4	█	140	0.12	1.0	█	–	–	–	█	110	0.12	1.0	–	–	–	–	–	–
	T8430	0.4	█	140	0.12	1.0	█	–	–	–	█	110	0.12	1.0	–	–	–	–	–	–
	T9325	0.4	█	140	0.12	1.0	█	–	–	–	█	110	0.12	1.0	–	–	–	–	–	–
TCMT 16T304E-FF2	T8330	0.4	█	140	0.12	0.8	█	–	–	–	█	110	0.12	0.8	–	–	–	–	–	–
	T8430	0.4	█	140	0.12	0.8	█	–	–	–	█	110	0.12	0.8	–	–	–	–	–	–
	T9325	0.4	█	140	0.12	0.8	█	–	–	–	█	110	0.12	0.8	–	–	–	–	–	–
TCMT 16T308E-FF2	TT010	0.4	█	150	0.06	0.5	█	–	–	–	–	–	–	–	–	–	–	–	–	–
	T8330	0.8	█	130	0.17	0.8	█	–	–	–	█	105	0.17	0.8	–	–	–	–	–	–
	T8430	0.8	█	130	0.17	0.8	█	–	–	–	█	105	0.17	0.8	–	–	–	–	–	–
T9325	0.8	█	130	0.17	0.8	█	–	–	–	█	105	0.17	0.8	–	–	–	–	–	–	–

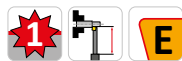

Géométrie FM pour l'usinage de la finition à la semi-ébauche et pour les coupes continues à légèrement interrompues.

TCMT 16T304E-FM	T7325	0.4	█	130	0.19	1.7	█	100	0.17	1.7	–	–	–	–	–	–	–	–	–	–	
	T8330	0.4	█	140	0.12	1.7	█	90	0.11	1.7	█	110	0.12	1.7	█	360	0.14	1.7	–	–	–
	T8430	0.4	█	140	0.12	1.7	█	90	0.11	1.7	█	110	0.12	1.7	█	360	0.14	1.7	–	–	–

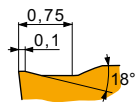

Géométrie FM2 pour l'usinage de la finition à moyen et pour des coupes continues à interrompues.

TCMT 16T308E-FM2	T8330	0.8	█	130	0.20	1.0	█	85	0.18	1.0	█	100	0.20	1.0	–	–	–	–	–	–
	T8430	0.8	█	130	0.20	1.0	█	85	0.18	1.0	█	100	0.20	1.0	–	–	–	–	–	–
	T9325	0.8	█	130	0.20	1.0	█	100	0.18	1.0	█	100	0.20	1.0	–	–	–	–	–	–

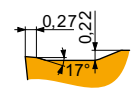

Géométrie RM pour l'usinage de la semi-ébauche à l'ébauche et pour les coupes continues à interrompues.

TCMT 16T308E-RM	T5315	0.8	█	120	0.27	1.9	█	–	–	–	█	95	0.27	1.9	–	–	–	–	–	–	
	T8330	0.8	█	120	0.27	1.9	█	85	0.24	1.9	█	95	0.27	1.9	–	–	–	█	26	0.19	1.5
	T8430	0.8	█	120	0.27	1.9	█	85	0.24	1.9	█	95	0.27	1.9	–	–	–	█	23	0.19	1.5



Adéquation et valeurs de départ pour la vitesse de coupe (vc), l'avance (f) et la profondeur de coupe (ap). Reportez-vous à notre application "Calculators" pour d'autres calculs.

Produit	RE (mm)	P			M			K			N			S			H		
		vc (m/min)	f (mm/rev)	ap (mm)	vc (m/min)	f (mm/rev)	ap (mm)	vc (m/min)	f (mm/rev)	ap (mm)	vc (m/min)	f (mm/rev)	ap (mm)	vc (m/min)	f (mm/rev)	ap (mm)	vc (m/min)	f (mm/rev)	ap (mm)

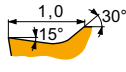

Géométrie UR pour l'usinage de la finition fine à la finition et pour les coupes continues à légèrement interrompues.

TCMT 16T304E-UR	T8330	0.4	135	0.12	0.8	80	0.11	0.8	110	0.12	0.8	-	-	-	-	-	-	-	-
	T8430	0.4	140	0.12	0.8	85	0.11	0.8	110	0.12	0.8	-	-	-	-	-	-	-	-
	T9325	0.4	130	0.18	0.8	100	0.16	0.8	105	0.18	0.8	-	-	-	-	-	-	-	-
TCMT 16T308E-UR	TT310	0.4	140	0.12	0.8	110	0.11	0.8	-	-	-	-	-	-	-	-	-	-	-
	T8330	0.8	130	0.17	0.8	90	0.15	0.8	105	0.17	0.8	-	-	-	-	-	-	-	-
	T8430	0.8	130	0.17	0.8	90	0.15	0.8	105	0.17	0.8	-	-	-	-	-	-	-	-
	T9325	0.8	130	0.17	0.8	100	0.15	0.8	105	0.17	0.8	-	-	-	-	-	-	-	-

TCMW



	IC (mm)	D1 (mm)	L (mm)	S (mm)
16T3	9.525	4.40	16.50	3.97

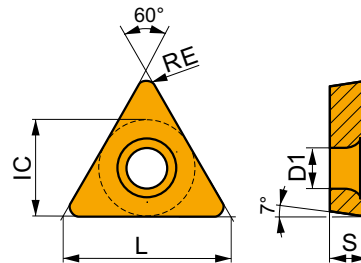

Adéquation et valeurs de départ pour la vitesse de coupe (vc), l'avance (f) et la profondeur de coupe (ap). Reportez-vous à notre application "Calculators" pour d'autres calculs.

Produit	RE (mm)	P			M			K			N			S			H		
		vc (m/min)	f (mm/rev)	ap (mm)	vc (m/min)	f (mm/rev)	ap (mm)	vc (m/min)	f (mm/rev)	ap (mm)	vc (m/min)	f (mm/rev)	ap (mm)	vc (m/min)	f (mm/rev)	ap (mm)	vc (m/min)	f (mm/rev)	ap (mm)

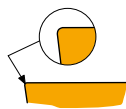

Pour l'usinage de la finition fine à la semi-ébauche et pour des coupes continues à légèrement interrompues.

TCMW 16T304	T5305	0.4	-	-	-	-	-	-	115	0.10	1.5	-	-	-	-	-	-	30	0.15	1.0
	T5315	0.4	-	-	-	-	-	-	115	0.10	1.5	-	-	-	-	-	-	26	0.15	1.0
	T6310	0.4	-	-	-	-	-	-	85	0.10	1.5	-	-	-	-	-	-	15	0.15	1.0
TCMW 16T308	T5305	0.8	-	-	-	-	-	-	105	0.18	1.5	-	-	-	-	-	-	30	0.15	1.0
	T5315	0.8	-	-	-	-	-	-	105	0.18	1.5	-	-	-	-	-	-	26	0.15	1.0
	T6310	0.8	-	-	-	-	-	-	85	0.18	1.5	-	-	-	-	-	-	15	0.15	1.0



ATTACHEMENTS



DÉSIGNATION DE L'ATTACHEMENT

1	2	3	4	5
AS 3	30	022	100	R

1		2	3	4		5	
Type d'attachement		Cône	Taille	Longueur PM		Version	
AS 3	DIN 69871	30	022	055	55 mm	R	Arrosage interne
BT 3	MAS BT	40	027	100	100 mm		
HSK	HSK	63A	032				
OTT 3	DIN 2080	50	042				
3	MORSE	05	054				
B	WELDON	25	068				
P	EXTENSION		085				
R	RÉDUCTION		100				
ADT	ADAPTATEUR		200				
			300				
			400				
			500				



69871-BS





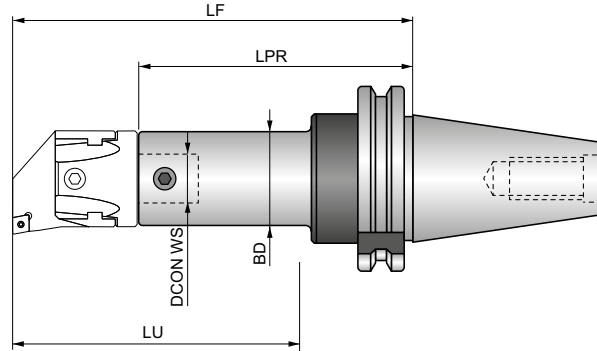

Attachement avec accouplement DIN 69871 pour têtes d'alésage

Attachement très rigide DIN 69871 (pour ATC) pour têtes d'alésage, disponible avec arrosage centralisé et avec cônes 30, 40 et 50. Différentes longueurs d'arbre disponibles. Les tailles d'accouplement de 22 à 160 mm peuvent être utilisées avec les extensions EXT-BS, les réducteurs RED-BS et les adaptateurs agrandisseurs LA-BS. Pour les applications nécessitant une précision et une répétabilité élevées.



Produit		CZC MS	BD	DCON WS	LF	LPR	LU			
AS 330 022 100 R	30	22	22.00	12.00	138.00	104	100.00	✓	US 0608	0.72
AS 330 027 055 R	30	27	27.00	15.00	90.00	48	55.00	✓	US 0609	0.56
AS 330 027 100 R	30	27	27.00	15.00	138.00	96	100.00	✓	US 0609	0.68
AS 330 032 060 R	30	32	32.00	20.00	96.00	51	60.00	✓	US 0810	0.51
AS 330 032 100 R	30	32	32.00	20.00	138.00	93	100.00	✓	US 0810	0.74
AS 340 022 080 R	40	22	22.00	12.00	118.00	84	80.00	✓	US 0608	1.14
AS 340 022 100 R	40	22	22.00	12.00	138.00	104	100.00	✓	US 0608	1.24
AS 340 027 055 R	40	27	27.00	15.00	90.00	48	55.00	✓	US 0609	1.05
AS 340 027 100 R	40	27	27.00	15.00	138.00	96	100.00	✓	US 0609	1.30
AS 340 027 130 R	40	27	27.00	15.00	168.00	126	130.00	✓	US 0609	1.43
AS 340 032 060 R	40	32	32.00	20.00	96.00	51	60.00	✓	US 0810	1.10
AS 340 032 100 R	40	32	32.00	20.00	138.00	93	100.00	✓	US 0810	1.35
AS 340 032 130 R	40	32	32.00	20.00	168.00	123	130.00	✓	US 0810	1.52
AS 340 042 075 R	40	42	42.00	24.00	112.00	56	75.00	✓	US 1014	1.16
AS 340 042 160 R	40	42	42.00	24.00	182.00	126	160.00	✓	US 1014	1.90
AS 340 042 200 R	40	42	42.00	24.00	222.00	166	200.00	✓	US 1014	2.37
AS 340 054 120 R	40	54	54.00	28.00	142.00	76	120.00	✓	US 1219	1.58
AS 340 054 160 R	40	54	54.00	28.00	182.00	116	160.00	✓	US 1219	2.28
AS 340 054 200 R	40	54	54.00	28.00	222.00	156	200.00	✓	US 1219	2.93
AS 340 068 160 R	40	68	68.00	36.00	183.00	97	160.00	✓	US 1625	2.36
AS 340 068 200 R	40	68	68.00	36.00	223.00	137	200.00	✓	US 1625	3.50
AS 340 085 200 R	40	85	85.00	50.00	224.00	124	200.00	✓	US 1630	3.96
AS 340 100 200 R	40	100, 200	100.00	60.00	224.00	124	200.00	✓	US 2032	5.21
AS 350 022 080 R	50	22	22.00	12.00	118.00	84	80.00	✓	US 0608	3.43
AS 350 022 100 R	50	22	22.00	12.00	138.00	104	100.00	✓	US 0608	3.40
AS 350 027 055 R	50	27	27.00	15.00	90.00	48	55.00	✓	US 0609	3.30
AS 350 027 100 R	50	27	27.00	15.00	138.00	96	100.00	✓	US 0609	3.48
AS 350 027 130 R	50	27	27.00	15.00	168.00	126	130.00	✓	US 0609	3.48
AS 350 032 060 R	50	32	32.00	20.00	96.00	51	60.00	✓	US 0810	2.98
AS 350 032 130 R	50	32	32.00	20.00	168.00	123	130.00	✓	US 0810	3.71
AS 350 032 160 R	50	32	32.00	20.00	198.00	153	160.00	✓	US 0810	3.95
AS 350 042 075 R	50	42	42.00	24.00	112.00	56	75.00	✓	US 1014	3.32
AS 350 042 160 R	50	42	42.00	24.00	198.00	142	160.00	✓	US 1014	4.26
AS 350 042 200 R	50	42	42.00	24.00	238.00	182	200.00	✓	US 1014	4.74



Produit		CZC MS	BD	DCON WS	LF	LPR	LU			
			(mm)	(mm)	(mm)	(mm)	(mm)			
AS 350 054 090 R	50	54	54.00	28.00	128.00	62	90.00	✓	US 1219	3.39
AS 350 054 160 R	50	54	54.00	28.00	198.00	132	160.00	✓	US 1219	4.74
AS 350 054 200 R	50	54	54.00	28.00	238.00	172	200.00	✓	US 1219	5.48
AS 350 068 115 R	50	68	68.00	36.00	151.00	65	115.00	✓	US 1625	3.66
AS 350 068 200 R	50	68	68.00	36.00	223.00	137	200.00	✓	US 1625	5.81
AS 350 068 260 R	50	68	68.00	36.00	283.00	197	260.00	✓	US 1625	7.48
AS 350 085 200 R	50	85	85.00	50.00	224.00	124	200.00	✓	US 1630	6.21
AS 350 085 260 R	50	85	85.00	50.00	284.00	184	260.00	✓	US 1630	8.91
AS 350 085 320 R	50	85	85.00	50.00	344.00	244	320.00	✓	US 1630	11.50
AS 350 100 190 R	50	100, 200	100.00	60.00	214.00	114	190.00	✓	US 2032	6.52
AS 350 100 260 R	50	100, 200	100.00	60.00	284.00	184	260.00	✓	US 2032	10.85
AS 350 100 320 R	50	100, 200	100.00	60.00	344.00	244	320.00	✓	US 2032	14.47
AS 550 160	50	300, 400, 500	100.00	60.00	160.00	70	125.00	–	US 1240	5.55



BT-BS





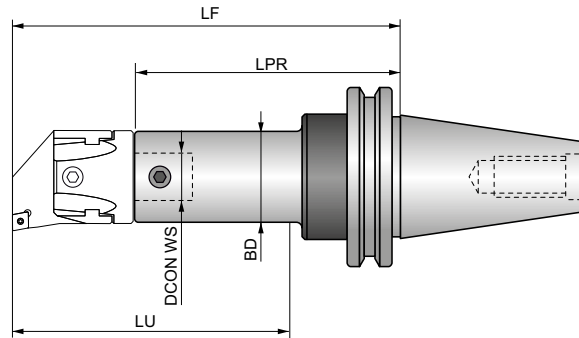

Attachement avec accouplement MAS-403-BT pour têtes d'alésage

Attachement très rigide MAS 403-BT (pour ATC) pour têtes d'alésage, disponible avec arrosage centralisé et avec cônes 30, 40 et 50. Différentes longueurs d'arbre disponibles. Les tailles d'accouplement de 22 à 160 mm peuvent être utilisées avec les extensions EXT-BS, les réducteurs RED-BS et les adaptateurs agrandisseurs LA-BS. Pour les applications nécessitant une précision et une répétabilité élevées.



Produit		CZC MS	BD	DCON WS	LF	LPR	LU			
BT 330 022 100 R	30	22	22.00	12.00	125.00	91	100.00	✓	US 0608	0.56
BT 330 027 055 R	30	27	27.00	15.00	77.00	35	55.00	✓	US 0609	0.41
BT 330 027 100 R	30	27	27.00	15.00	125.00	83	100.00	✓	US 0609	0.69
BT 330 032 060 R	30	32	32.00	20.00	83.00	38	60.00	✓	US 0810	0.47
BT 330 032 100 R	30	32	32.00	20.00	125.00	80	100.00	✓	US 0810	0.70
BT 330 042 075 R	30	42	42.00	24.00	100.00	44	75.00	✓	US 1014	0.56
BT 340 022 050 R	40	22	22.00	12.00	80.00	46	50.00	✓	US 0608	1.02
BT 340 022 080 R	40	22	22.00	12.00	110.00	76	80.00	✓	US 0608	1.16
BT 340 022 100 R	40	22	22.00	12.00	130.00	96	100.00	✓	US 0608	1.14
BT 340 027 055 R	40	27	27.00	15.00	82.00	40	55.00	✓	US 0609	1.06
BT 340 027 100 R	40	27	27.00	15.00	130.00	88	100.00	✓	US 0609	1.26
BT 340 027 130 R	40	27	27.00	15.00	160.00	118	130.00	✓	US 0609	1.39
BT 340 032 060 R	40	32	32.00	20.00	88.00	43	60.00	✓	US 0810	1.00
BT 340 032 100 R	40	32	32.00	20.00	130.00	85	100.00	✓	US 0810	1.31
BT 340 032 130 R	40	32	32.00	20.00	160.00	115	130.00	✓	US 0810	1.50
BT 340 042 075 R	40	42	42.00	24.00	104.00	48	75.00	✓	US 1014	1.14
BT 340 042 160 R	40	42	42.00	24.00	190.00	134	160.00	✓	US 1014	2.05
BT 340 042 200 R	40	42	42.00	24.00	230.00	174	200.00	✓	US 1014	2.39
BT 340 054 090 R	40	54	54.00	28.00	120.00	54	90.00	✓	US 1219	1.13
BT 340 054 160 R	40	54	54.00	28.00	190.00	124	160.00	✓	US 1219	2.55
BT 340 054 200 R	40	54	54.00	28.00	230.00	164	200.00	✓	US 1219	3.10
BT 340 068 160 R	40	68	68.00	36.00	181.00	95	160.00	✓	US 1625	2.46
BT 340 068 200 R	40	68	68.00	36.00	221.00	135	200.00	✓	US 1625	3.64
BT 340 085 200 R	40	85	85.00	50.00	220.00	120	200.00	✓	US 1630	4.04
BT 340 100 200 R	40	100	100.00	60.00	220.00	120	200.00	✓	US 2032	4.95
BT 350 022 080 R	50	22	22.00	12.00	121.00	87	80.00	✓	US 0608	3.95
BT 350 022 100 R	50	22	22.00	12.00	141.00	107	100.00	✓	US 0608	3.50
BT 350 027 055 R	50	27	27.00	15.00	93.00	51	55.00	✓	US 0609	3.68
BT 350 027 100 R	50	27	27.00	15.00	141.00	99	100.00	✓	US 0609	4.00
BT 350 027 130 R	50	27	27.00	15.00	171.00	129	130.00	✓	US 0609	4.14
BT 350 032 060 R	50	32	32.00	20.00	99.00	54	60.00	✓	US 0810	3.67
BT 350 032 130 R	50	32	32.00	20.00	171.00	126	130.00	✓	US 0810	4.24
BT 350 032 160 R	50	32	32.00	20.00	201.00	156	160.00	✓	US 0810	4.56
BT 350 042 075 R	50	42	42.00	24.00	115.00	59	75.00	✓	US 1014	3.84



Produit		CZC MS	BD	DCON WS	LF	LPR	LU			
			(mm)	(mm)	(mm)	(mm)	(mm)			
BT 350 042 160 R	50	42	42.00	24.00	201.00	145	160.00	✓	US 1014	4.89
BT 350 042 200 R	50	42	42.00	24.00	241.00	185	200.00	✓	US 1014	5.25
BT 350 054 090 R	50	54	54.00	28.00	131.00	65	90.00	✓	US 1219	3.90
BT 350 054 160 R	50	54	54.00	28.00	201.00	135	160.00	✓	US 1219	5.39
BT 350 054 200 R	50	54	54.00	28.00	241.00	175	200.00	✓	US 1219	5.98
BT 350 068 115 R	50	68	68.00	36.00	154.00	68	115.00	✓	US 1625	4.09
BT 350 068 200 R	50	68	68.00	36.00	242.00	156	200.00	✓	US 1625	6.66
BT 350 068 260 R	50	68	68.00	36.00	302.00	216	260.00	✓	US 1625	8.18
BT 350 085 200 R	50	85	85.00	50.00	242.00	142	200.00	✓	US 1630	7.40
BT 350 085 260 R	50	85	85.00	50.00	302.00	202	260.00	✓	US 1630	9.89
BT 350 085 320 R	50	85	85.00	50.00	362.00	262	320.00	✓	US 1630	12.76
BT 350 100 170 R	50	100, 200	100.00	60.00	195.00	95	170.00	✓	US 2032	5.71
BT 350 100 260 R	50	100, 200	100.00	60.00	302.00	202	260.00	✓	US 2032	12.34
BT 350 100 320 R	50	100, 200	100.00	60.00	362.00	262	320.00	✓	US 2032	14.50
BT 550 160	50	300, 400, 500	100.00	60.00	160.00	70	125.00	–	US 1240	6.05



HSK-BS



Attachement avec accouplement HSK pour têtes d'alésage

Attachement HSK très rigide (pour ATC) pour têtes d'alésage, disponible avec arrosage centralisé et avec cônes 50A, 63A ou 100A. Les tailles d'accouplement de 22 à 160 mm peuvent être utilisées en combinaison avec les extensions EXT-BS, les réducteurs RED-BS et les adaptateurs agrandisseurs LA-BS. Pour les applications nécessitant une précision et une répétabilité élevées.

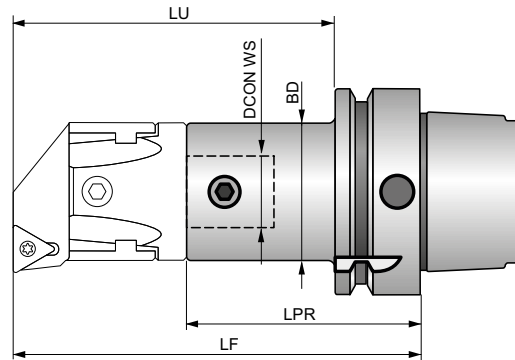

Produit		CZC MS	BD	DCON WS	LF	LPR	LU			
HSK 050A 022 055	50	22	22.00	12.00	81.00	47	55.00	—	US 0608	0.49
HSK 050A 027 065	50	27	27.00	15.00	91.00	49	65.00	—	US 0609	0.49
HSK 050A 032 075	50	32	32.00	20.00	101.00	56	75.00	—	US 0810	0.66
HSK 050A 042 090	50	42	42.00	24.00	116.00	60	90.00	—	US 1014	0.71
HSK 063A 022 055	63	22	22.00	12.00	81.00	47	55.00	—	US 0608	0.07
HSK 063A 027 065	63	27	27.00	15.00	91.00	49	65.00	—	US 0609	0.76
HSK 063A 032 075	63	32	32.00	20.00	101.00	56	75.00	—	US 0810	0.82
HSK 063A 042 090	63	42	42.00	24.00	116.00	60	90.00	—	US 1014	0.96
HSK 063A 054 110	63	54	54.00	28.00	136.00	70	110.00	—	US 1219	1.26
HSK 063A 068 145	63	68	68.00	36.00	171.00	85	145.00	—	US 1625	1.81
HSK 100A 022 055	100	22	22.00	12.00	89.00	55	55.00	—	US 0608	2.28
HSK 100A 027 065	100	27	27.00	15.00	99.00	57	65.00	—	US 0609	2.34
HSK 100A 032 075	100	32	32.00	20.00	104.00	59	75.00	—	US 0810	2.73
HSK 100A 042 090	100	42	42.00	24.00	119.00	63	90.00	—	US 1014	2.45
HSK 100A 054 110	100	54	54.00	28.00	139.00	73	110.00	—	US 1219	2.79
HSK 100A 068 145	100	68	68.00	36.00	174.00	88	145.00	—	US 1625	3.52
HSK 100A 085 165	100	85	85.00	50.00	194.00	94	165.00	—	US 1630	4.15
HSK 100A 100 185	100	100, 200	100.00	60.00	214.00	114	185.00	—	US 2032	5.63
HSK 550 160	100	300, 400, 500	100.00	60.00	170.00	80	140.00	—	US 1240	5.24



2080-BS

PRAMET





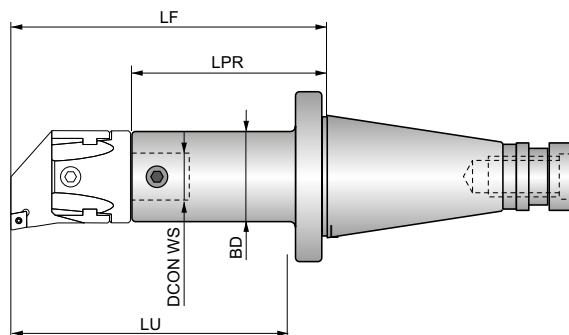

Attachement avec accouplement DIN 2080 pour têtes d'alésage

Attachement très rigide DIN 2080 (pour MTC) pour têtes d'alésage, disponible avec arrosage centralisé et avec cônes 40 et 50. Différentes longueurs d'arbre disponibles. Les tailles d'accouplement de 22 à 160 mm peuvent être utilisées en combinaison avec les extensions EXT-BS, les réducteurs RED-BS et les adaptateurs agrandisseurs LA-BS. Pour les applications nécessitant une précision et une répétabilité élevées.



Produit		CZC MS	BD	DCON WS	LF	LPR	LU			
OTT 340 022 080 R	40	22	22.00	12.00	95.00	61	80.00	✓	US 0608	0.88
OTT 340 022 100 R	40	22	22.00	12.00	115.00	81	100.00	✓	US 0608	0.94
OTT 340 027 055 R	40	27	27.00	15.00	67.00	25	55.00	✓	US 0609	0.86
OTT 340 027 100 R	40	27	27.00	15.00	115.00	73	100.00	✓	US 0609	1.00
OTT 340 027 130 R	40	27	27.00	15.00	145.00	103	130.00	✓	US 0609	1.12
OTT 340 032 060 R	40	32	32.00	20.00	73.00	28	60.00	✓	US 0810	0.90
OTT 340 032 100 R	40	32	32.00	20.00	115.00	70	100.00	✓	US 0810	1.10
OTT 340 032 130 R	40	32	32.00	20.00	145.00	100	130.00	✓	US 0810	1.22
OTT 340 042 075 R	40	42	42.00	24.00	89.00	33	75.00	✓	US 1014	0.89
OTT 340 042 160 R	40	42	42.00	24.00	175.00	119	160.00	✓	US 1014	1.73
OTT 340 042 200 R	40	42	42.00	24.00	215.00	159	200.00	✓	US 1014	2.30
OTT 340 054 090 R	40	54	54.00	28.00	105.00	39	90.00	✓	US 1219	1.08
OTT 340 054 160 R	40	54	54.00	28.00	175.00	109	160.00	✓	US 1219	2.23
OTT 340 054 200 R	40	54	54.00	28.00	215.00	149	200.00	✓	US 1219	3.06
OTT 340 068 160 R	40	68	68.00	36.00	175.00	90	160.00	✓	US 1625	2.40
OTT 340 068 200 R	40	68	68.00	36.00	216.00	130	200.00	✓	US 1625	3.73
OTT 340 085 200 R	40	85	85.00	50.00	211.00	111	200.00	✓	US 1630	4.03
OTT 340 100 200 R	40	100, 200	100.00	60.00	211.00	111	200.00	✓	US 2032	5.05
OTT 350 022 080 R	50	22	22.00	12.00	99.00	65	80.00	✓	US 0608	2.98
OTT 350 022 100 R	50	22	22.00	12.00	119.00	85	100.00	✓	US 0608	2.97
OTT 350 027 055 R	50	27	27.00	15.00	71.00	29	55.00	✓	US 0609	2.93
OTT 350 027 100 R	50	27	27.00	15.00	119.00	77	100.00	✓	US 0609	3.01
OTT 350 027 130 R	50	27	27.00	15.00	149.00	107	130.00	✓	US 0609	3.10
OTT 350 032 060 R	50	32	32.00	20.00	77.00	32	60.00	✓	US 0810	2.81
OTT 350 032 130 R	50	32	32.00	20.00	149.00	104	130.00	✓	US 0810	3.24
OTT 350 032 160 R	50	32	32.00	20.00	179.00	134	160.00	✓	US 0810	3.26
OTT 350 042 075 R	50	42	42.00	24.00	93.00	37	75.00	✓	US 1014	2.74
OTT 350 042 160 R	50	42	42.00	24.00	179.00	123	160.00	✓	US 1014	3.64
OTT 350 042 200 R	50	42	42.00	24.00	219.00	163	200.00	✓	US 1014	4.05
OTT 350 054 090 R	50	54	54.00	28.00	109.00	43	90.00	✓	US 1219	3.02
OTT 350 054 160 R	50	54	54.00	28.00	179.00	113	160.00	✓	US 1219	4.15
OTT 350 054 200 R	50	54	54.00	28.00	219.00	153	200.00	✓	US 1219	5.08
OTT 350 068 115 R	50	68	68.00	36.00	132.00	46	115.00	✓	US 1625	3.20
OTT 350 068 200 R	50	68	68.00	36.00	220.00	134	200.00	✓	US 1625	5.54



Produit		CZC MS	BD	DCON WS	LF	LPR	LU			
			(mm)	(mm)	(mm)	(mm)	(mm)			
OTT 350 068 260 R	50	68	68.00	36.00	280.00	194	260.00	✓	US 1625	7.22
OTT 350 085 200 R	50	85	85.00	50.00	221.00	121	200.00	✓	US 1630	6.21
OTT 350 085 260 R	50	85	85.00	50.00	281.00	181	260.00	✓	US 1630	9.07
OTT 350 085 320 R	50	85	85.00	50.00	341.00	241	320.00	✓	US 1630	11.84
OTT 350 100 170 R	50	100, 200	100.00	60.00	193.00	93	170.00	✓	US 2032	5.60
OTT 350 100 260 R	50	100, 200	100.00	60.00	281.00	181	260.00	✓	US 2032	10.78
OTT 350 100 320 R	50	100, 200	100.00	60.00	341.00	241	320.00	✓	US 2032	15.10
OTT 550 160	50	300, 400, 500	100.00	60.00	160.00	70	125.00	–	US 1240	5.90



MOR-BS



Attachement cône Morse pour têtes d'alésage

Attachement cône morse n°5 très rigide pour têtes d'alésage. Différentes longueurs d'arbre disponibles avec arrosage centralisé. Les tailles d'accouplement de 22 à 160 mm peuvent être utilisées en combinaison avec les extensions EXT-BS, les réducteurs RED-BS et les adaptateurs agrandisseurs LA-BS. Pour les applications nécessitant une précision et une répétabilité élevées.

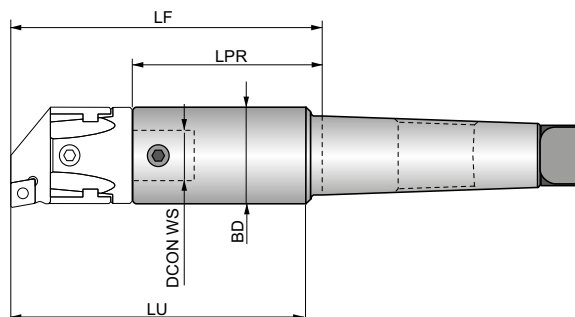

Produit	CCTMS	CZC MS	BD	DCON WS	LF	LPR	LU			
			(mm)	(mm)	(mm)	(mm)	(mm)			
305 022 100	5	22	22.00	12.00	112.00	78	100.00	–	US 0608	1.64
305 022 130	5	22	22.00	12.00	142.00	108	130.00	–	US 0608	1.76
305 027 055	5	27	27.00	15.00	65.00	23	55.00	–	US 0609	1.58
305 027 100	5	27	27.00	15.00	113.00	71	100.00	–	US 0609	1.69
305 027 130	5	27	27.00	15.00	143.00	101	130.00	–	US 0609	1.84
305 032 060	5	32	32.00	20.00	70.00	25	60.00	–	US 0810	1.54
305 032 130	5	32	32.00	20.00	143.00	98	130.00	–	US 0810	1.95
305 032 160	5	32	32.00	20.00	173.00	128	160.00	–	US 0810	2.13
305 042 075	5	42	42.00	24.00	83.00	27	75.00	–	US 1014	1.50
305 042 130	5	42	42.00	24.00	188.00	86	130.00	–	US 1014	2.18
305 042 160	5	42	42.00	24.00	218.00	116	160.00	–	US 1014	2.51
305 054 160	5	54	54.00	28.00	172.00	106	160.00	–	US 1219	3.00
305 054 200	5	54	54.00	28.00	212.00	146	200.00	–	US 1219	3.63
305 068 140	5	68	68.00	36.00	146.00	60	140.00	–	US 1625	2.53
305 068 200	5	68	68.00	36.00	212.00	126	200.00	–	US 1625	4.47
305 068 260	5	68	68.00	36.00	272.00	186	260.00	–	US 1625	6.20
305 085 200	5	85	85.00	50.00	216.00	116	200.00	–	US 1630	5.40
305 085 260	5	85	85.00	50.00	276.00	176	260.00	–	US 1630	8.45
305 085 320	5	85	85.00	50.00	336.00	236	320.00	–	US 1630	0.01
305 100 260	5	100, 200	100.00	60.00	276.00	176	260.00	–	US 2032	7.95
305 100 320	5	100, 200	100.00	60.00	336.00	236	320.00	–	US 2032	11.39
505 160	5	300, 400, 500	100.00	60.00	146.00	56	140.00	–	US 2032	4.70



WEL-BS



Attachement avec accouplement WELDON pour têtes d'alésage

Attachement Weldon très rigide pour têtes d'alésage, diamètres de queue de 20 à 40 mm. Porte-outils de différentes longueurs disponibles avec arrosage centralisé. Les accouplements de 22 à 42 mm peuvent être utilisés en combinaison avec les extensions EXT-BS et les réducteurs RED-BS. Pour les applications nécessitant une précision et une répétabilité élevées.

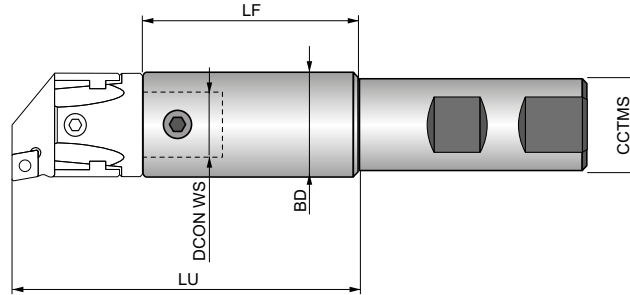

Produit	CCTMS	CZC MS	BD	DCON WS	LU			
			(mm)	(mm)	(mm)			
B 020 022 050	20	22	22.00	12.00	50.00	–	US 0608	0.17
B 020 022 100	20	22	22.00	12.00	100.00	–	US 0608	0.34
B 025 027 055	25	27	27.00	15.00	55.00	–	US 0609	0.17
B 025 027 100	25	27	27.00	15.00	95.00	–	US 0609	0.46
B 032 032 060	32	32	32.00	20.00	60.00	–	US 0810	0.43
B 032 032 100	32	32	32.00	20.00	100.00	–	US 0810	0.69
B 032 032 160	32	32	32.00	20.00	160.00	–	US 0810	1.11
B 032 042 090	32	32	32.00	24.00	90.00	–	US 0810	0.71
B 040 042 090	40	42	42.00	24.00	90.00	–	US 1014	0.98
B 040 042 160	40	42	42.00	24.00	160.00	–	US 1014	1.79



EXT-BS

PRAMET



Extension EXT-BS pour montage de tête d'alésage

Extension pour tête d'alésage. Tailles d'accouplement de 22 à 200 mm et différentes longueurs disponibles avec ou sans arrosage centralisé. Convient à toutes les applications nécessitant une précision et une répétabilité élevées.

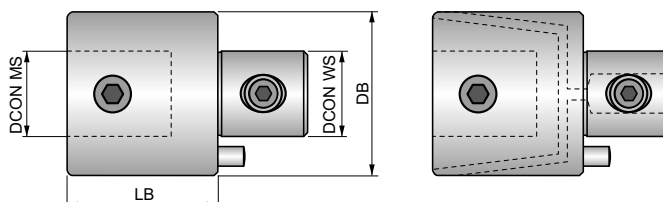

Produit	CZC MS	BD	DCON MS	DCON WS	LB			
		(mm)	(mm)	(mm)	(mm)			
P 022 030 R	22	22.00	12.00	12.00	30.00	✓	US 0608	0.09
P 027 030 R	27	27.00	15.00	15.00	30.00	✓	US 0609	0.13
P 032 035 R	32	32.00	20.00	20.00	35.00	✓	US 0810	0.20
P 042 040 R	42	42.00	24.00	24.00	40.00	✓	US 1014	0.40
P 054 050 R	54	54.00	28.00	28.00	50.00	✓	US 1219	0.85
P 068 060 R	68	68.00	36.00	36.00	60.00	✓	US 1625	1.61
P 085 070 R	85	85.00	50.00	50.00	70.00	✓	US 1630	2.88
P 100 080 R	100, 200	100.00	60.00	60.00	80.00	✓	US 2032	4.48
P 022 020	22	22.00	12.00	12.00	20.00	–	US 0608	0.06
P 022 030	22	22.00	12.00	12.00	30.00	–	US 0608	0.09
P 027 030	27	27.00	15.00	15.00	30.00	–	US 0609	0.13
P 027 045	27	27.00	15.00	15.00	45.00	–	US 0609	0.19
P 032 035	32	32.00	20.00	20.00	35.00	–	US 0810	0.20
P 032 052	32	32.00	20.00	20.00	52.00	–	US 0810	0.30
P 042 040	42	42.00	24.00	24.00	40.00	–	US 1014	0.40
P 042 060	42	42.00	24.00	24.00	60.00	–	US 1014	0.60
P 054 050	54	54.00	28.00	28.00	50.00	–	US 1219	0.87
P 054 075	54	54.00	28.00	28.00	75.00	–	US 1219	1.30
P 068 060	68	68.00	36.00	36.00	60.00	–	US 1625	1.63
P 068 090	68	68.00	36.00	36.00	90.00	–	US 1625	2.44
P 085 070	85	85.00	50.00	50.00	70.00	–	US 1630	2.86
P 085 105	85	85.00	50.00	50.00	105.00	–	US 1630	4.46
P 100 080	100, 200	100.00	60.00	60.00	80.00	–	US 2032	4.44
P 100 120	100, 200	100.00	60.00	60.00	120.00	–	US 2032	6.91



RED-BS



Réducteur RED-BS pour montage de tête d'alésage

Réducteur pour tête d'alésage. Tailles d'accouplement de 27 à 100 mm et en différentes longueurs disponibles. Arrosage externe uniquement. Convient à toutes les applications nécessitant une précision et une répétabilité élevées.

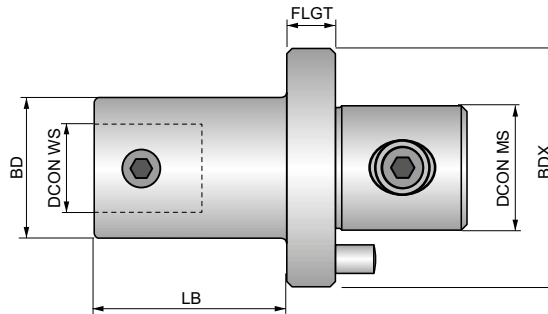

Produit	CZC MS	BDX	DCON MS	BD	DCON WS	LB	FLGT			
		(mm)	(mm)	(mm)	(mm)	(mm)	(mm)			
R 027 022 036	22	27.00	15.00	22	12.00	26.00	10	—	US 0608	0.11
R 042 022 058	22	42.00	24.00	22	12.00	48.00	10	—	US 0608	0.31
R 032 022 040	22	32.00	20.00	22	12.00	30.00	10	—	US 0608	0.17
R 054 022 086	22	54.00	28.00	22	12.00	76.00	10	—	US 0608	0.51
R 068 022 102	22	68.00	36.00	22	12.00	90.00	12	—	US 0608	0.90
R 054 027 080	27	54.00	28.00	27	15.00	70.00	10	—	US 0609	0.63
R 032 027 034	27	32.00	20.00	27	15.00	24.00	10	—	US 0609	0.18
R 042 027 050	27	42.00	24.00	27	15.00	40.00	10	—	US 0609	0.33
R 068 027 095	27	68.00	36.00	27	15.00	83.00	12	—	US 0609	0.97
R 042 032 046	32	42.00	24.00	32	20.00	36.00	10	—	US 0810	0.36
R 054 032 076	32	54.00	28.00	32	20.00	66.00	10	—	US 0810	0.63
R 068 032 090	32	68.00	36.00	32	20.00	78.00	12	—	US 0810	1.08
R 054 042 070	42	54.00	28.00	42	24.00	60.00	10	—	US 1014	0.81
R 068 042 082	42	68.00	36.00	42	24.00	70.00	12	—	US 1014	1.26
R 085 042 095	42	85.00	50.00	42	24.00	83.00	12	—	US 1014	2.06
R 068 054 072	54	68.00	36.00	54	28.00	60.00	12	—	US 1219	1.51
R 085 054 090	54	85.00	50.00	54	28.00	78.00	12	—	US 1219	2.44
R 085 068 100	68	85.00	50.00	68	36.00	88.00	12	—	US 1625	3.32
R 100 085 100	85	100.00	60.00	85	50.00	88.00	12	—	US 1630	5.05



LA-BS



Adaptateur LA-BS agrandisseur de tête d'alésage

Adaptateur agrandisseur de tête d'alésage. Disponible en taille d'accouplement 100 mm et en différentes longueurs pour augmenter la polyvalence. Arrosage externe uniquement. Convient à toutes les applications nécessitant une précision et une répétabilité élevées.

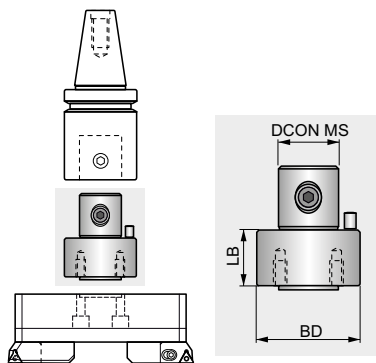

Produit	CZC MS	BD (mm)	DCON MS (mm)	LB (mm)			
ADT 100 050	300, 400, 500	100.00	60.00	50.00	–	US 1240	4.35



KITS D'ALÉSAGE



DÉSIGNATION DES KITS D'ALÉSAGE

1	2	3	4	5
BS	54	KIT	RC	8-43

1		2	3		4		5
Type d'outil		Taille	Type		Type de barre ISO		Plage de diamètre d'alésage
BS	Type d'outil	54	KIT	Set d'outils	RC	pour forme plaquette C $\kappa = 95^\circ$	
						pour forme plaquette T $\kappa = 90^\circ$	
					TC	8 – 43 (mm)	
						8 – 100 (mm)	
					TC	8 – 170 (mm)	
						8 – 210 (mm)	

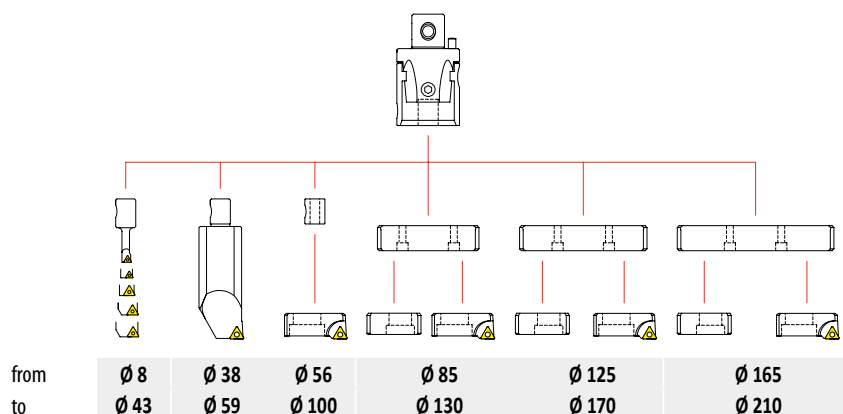

Plage	Composants				Référence	
Ø 8 ~ Ø 43					BS 54 KIT RC 8-043	420
					BS 54 KIT TC 8-043	424
Ø 8 ~ Ø 100					BS 54 KIT RC 8-100	421
					BS 54 KIT TC 8-100	425
Ø 8 ~ Ø 170					BS 54 KIT RC 8-170	422
					BS 54 KIT TC 8-170	426
Ø 8 ~ Ø 210					BS 54 KIT RC 8-210	423
					BS 54 KIT TC 8-210	427



BS 54 KIT RC 8-100

KITS D'ALÉSAGE

Ø 8 – 100

RÉFÉRENCE:



	Description	Marquage	Plaquette	Piè.
1	Tête d'alésage	BS 054 16	-	1
2	Barre d'alésage 6 mm	BS 06 16 R02	EP.. 0502..	1
	Barre d'alésage 8 mm	BS 08 16 R03	CC.. 0602..	1
	Barre d'alésage 10 mm	BS 10 16 R03	CC.. 0602..	1
	Barre d'alésage 12 mm	BS 12 16 R03	CC.. 0602..	1
	Barre d'alésage 16 mm	BS 16 16 R04	CC.. 09T3..	1
3	Barre d'alésage 34 mm	BS 34 16 R04	CC.. 09T3..	2
4	Cartouche	BS 2CT R04	CC.. 09T3..	1
5	Manchon de positionnement	BS 16 M10	-	1
6	Clé hexagonale 3	HK 03	-	1
	Clé hexagonale 5	HK 05	-	1
	Clé hexagonale 6	HK 06	-	1
	Clé hexagonale 8	HK 08	-	1
7	Clé Torx 7	TK07	-	1
	Clé Torx 8	TK08	-	1
	Clé Torx 15	TK15	-	1
8	Vis de cartouche	CS 10 25	-	1



BS 54 KIT RC 8-170

KITS D'ALÉSAGE

Ø 8 – 170

RÉFÉRENCE:

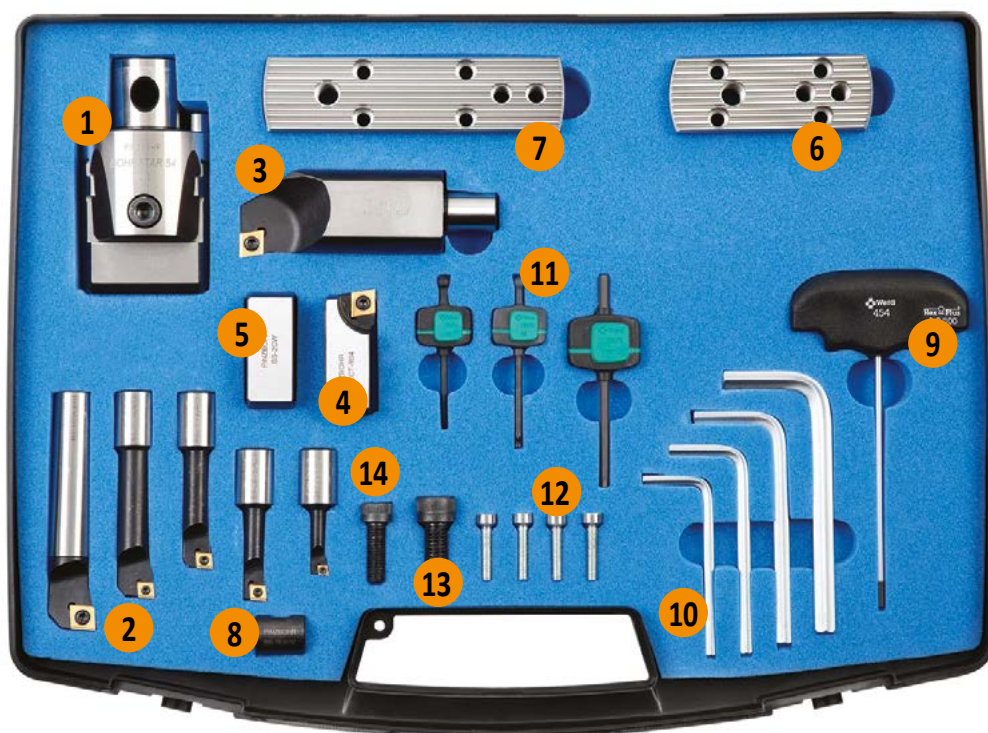

	Description	Marquage	Plaquette	Piè.
1	Tête d'alésage	BS 054 16	-	1
2	Barre d'alésage 6 mm	BS 06 16 R02	EP.. 0502..	1
	Barre d'alésage 8 mm	BS 08 16 R03	CC.. 0602..	1
	Barre d'alésage 10 mm	BS 10 16 R03	CC.. 0602..	1
	Barre d'alésage 12 mm	BS 12 16 R03	CC.. 0602..	1
	Barre d'alésage 16 mm	BS 16 16 R04	CC.. 09T3..	1
3	Barre d'alésage 34 mm	BS 34 16 R04	CC.. 09T3..	2
4	Cartouche	BS 2CT R04	CC.. 09T3..	1
5	Contrepoids	BS 2CW	-	1
6	Petite plaque	BS SP 85 130	-	1
7	Plaque moyenne	BS SP 125 170	-	1
8	Manchon de positionnement	BS 16 M10	-	1
9	Clé de réglage	AK 03	-	1
10	Clé hexagonale 4	HK 04	-	1
	Clé hexagonale 5	HK 05	-	1
	Clé hexagonale 6	HK 06	-	1
	Clé hexagonale 8	HK 08	-	1
11	Clé Torx 7	TK07	-	1
	Clé Torx 8	TK08	-	1
	Clé Torx 15	TK15	-	1
12	Vis de fixation de plaque	D 27 21	-	4
13	Vis de cartouche	CS 10 25	-	1
14	Vis de contrepois	CS 08 25	-	1

∅ 8 – 210

RÉFÉRENCE:

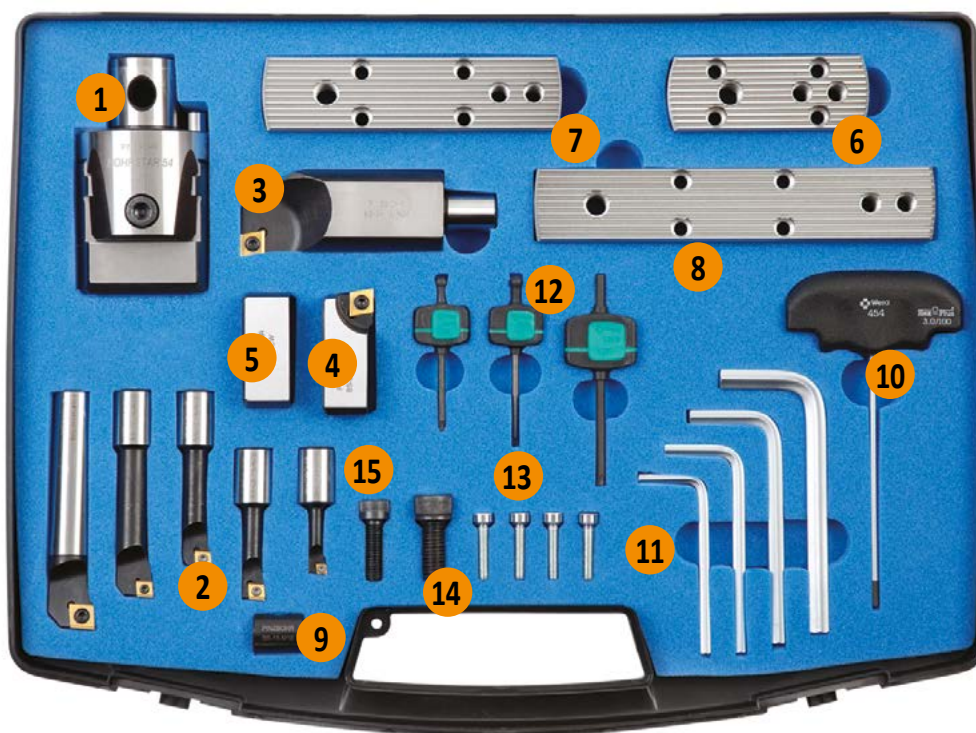

	Description	Marquage	Plaquette	Piè.
1	Tête d'alésage	BS 054 16	-	1
2	Barre d'alésage 6 mm	BS 06 16 R02	EP.. 0502..	1
	Barre d'alésage 8 mm	BS 08 16 R03	CC.. 0602..	1
	Barre d'alésage 10 mm	BS 10 16 R03	CC.. 0602..	1
	Barre d'alésage 12 mm	BS 12 16 R03	CC.. 0602..	1
	Barre d'alésage 16 mm	BS 16 16 R04	CC.. 09T3..	1
3	Barre d'alésage 34 mm	BS 34 16 R04	CC.. 09T3..	2
4	Cartouche	BS 2CT R04	CC.. 09T3..	1
5	Contrepoids	BS 2CW	-	1
6	Petite plaque	BS SP 85 130	-	1
7	Medium plate	BS SP 125 170	-	1
8	Longue plaque	BS SP 165 210	-	1
9	Manchon de positionnement	BS 16 M10	-	1
10	Clé de réglage	AK 03	-	1
11	Clé hexagonale 4	HK 04	-	1
	Clé hexagonale 5	HK 05	-	1
	Clé hexagonale 6	HK 06	-	1
	Clé hexagonale 8	HK 08	-	1
12	Clé Torx 7	TK07	-	1
	Clé Torx 8	TK08	-	1
	Clé Torx 15	TK15	-	1
13	Vis de fixation de plaque	D 27 21	-	4
14	Vis de cartouche	CS 10 25	-	1
15	Vis de contrepoids	CS 08 25	-	1

BS 54 KIT TC 8-043

KITS D'ALÉSAGE

Ø 8 – 43

RÉFÉRENCE:

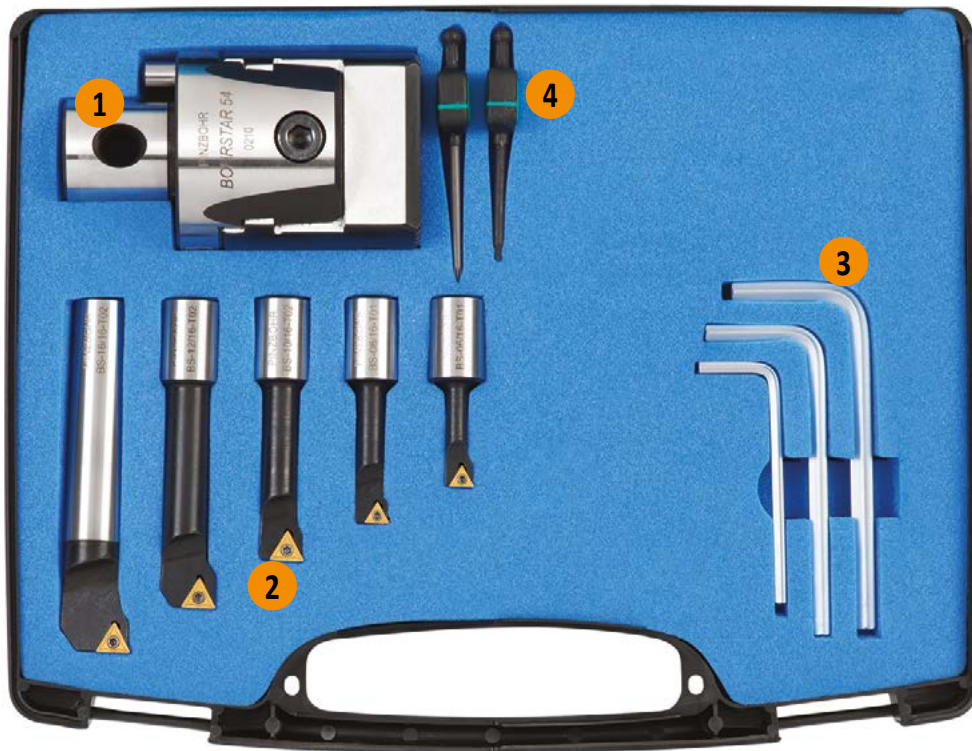

	Description	Marquage	Plaquette	Piè.
1	Tête d'alésage	BS 054 16	-	1
2	Barre d'alésage 6 mm	BS 06 16 T01	TC.. 06T1..	1
	Barre d'alésage 8 mm	BS 08 16 T01	TC.. 06T1..	1
	Barre d'alésage 10 mm	BS 10 16 T02	TC.. 0902..	1
	Barre d'alésage 12 mm	BS 12 16 T02	TC.. 0902..	1
	Barre d'alésage 16 mm	BS 16 16 T02	TC.. 0902..	1
3	Clé hexagonale 3	HK 03	-	1
	Clé hexagonale 5	HK 05	-	1
	Clé hexagonale 6	HK 06	-	1
4	Clé Torx 6	TK06	-	1
	Clé Torx 7	TK07	-	1

Ø 8 – 100

RÉFÉRENCE:



	Description	Marquage	Plaquette	Piè.
1	Tête d'alésage	BS 054 16	-	1
2	Barre d'alésage 6 mm	BS 06 16 T01	TC.. 06T1..	1
	Barre d'alésage 8 mm	BS 08 16 T01	TC.. 06T1..	1
	Barre d'alésage 10 mm	BS 10 16 T02	TC.. 0902..	1
	Barre d'alésage 12 mm	BS 12 16 T02	TC.. 0902..	1
	Barre d'alésage 16 mm	BS 16 16 T02	TC.. 0902..	1
3	Barre d'alésage 34 mm	BS 34 16 T04	TC.. 16T3..	1
4	Cartouche	BS 2CT T04	TC.. 16T3..	1
5	Manchon de positionnement	BS 16 M10	-	1
6	Clé hexagonale 3	HK 03	-	1
	Clé hexagonale 5	HK 05	-	1
	Clé hexagonale 6	HK 06	-	1
	Clé hexagonale 8	HK 08	-	1
7	Clé Torx 6	TK06	-	1
	Clé Torx 7	TK07	-	1
	Clé Torx 15	TK15	-	1
8	Vis de cartouche	CS 10 25	-	1

Ø 8 – 170

RÉFÉRENCE:

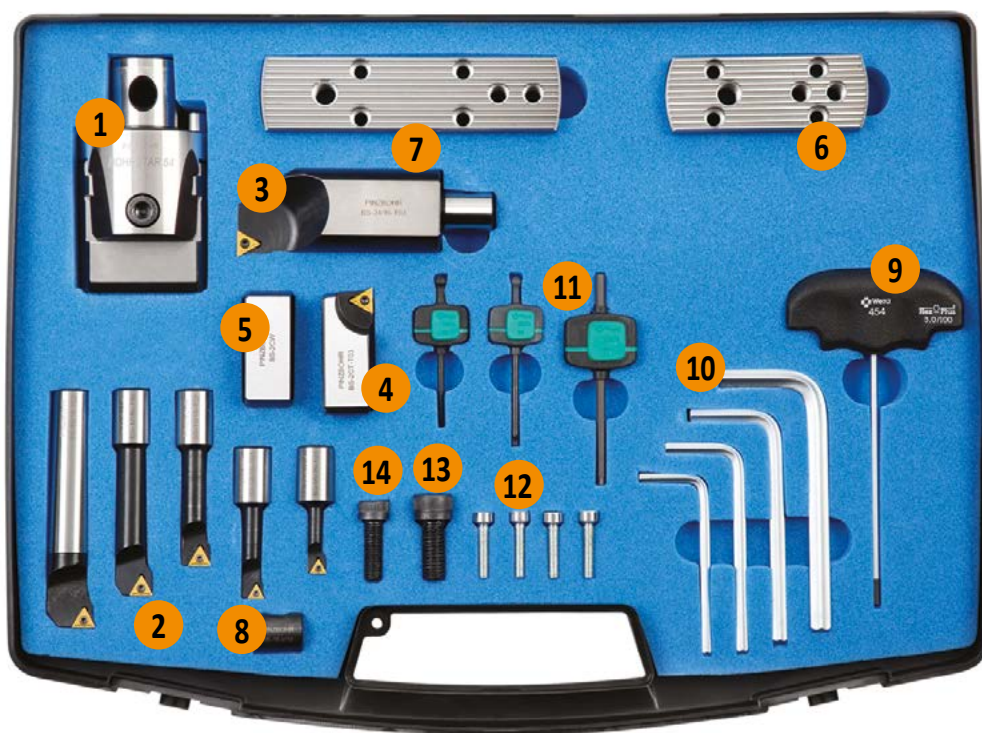

	Description	Marquage	Plaquette	Piè.
1	Tête d'alésage	BS 054 16	-	1
2	Barre d'alésage 6 mm	BS 06 16 T01	TC.. 06T1..	1
	Barre d'alésage 8 mm	BS 08 16 T01	TC.. 06T1..	1
	Barre d'alésage 10 mm	BS 10 16 T02	TC.. 0902..	1
	Barre d'alésage 12 mm	BS 12 16 T02	TC.. 0902..	1
	Barre d'alésage 16 mm	BS 16 16 T02	TC.. 0902..	1
3	Barre d'alésage 34 mm	BS 34 16 T04	TC.. 16T3..	1
4	Cartouche	BS 2CT T04	TC.. 16T3..	1
5	Contrepoids	BS 2CW	-	1
6	Petite plaque	BS SP 85 130	-	1
7	Plaque moyenne	BS SP 125 170	-	1
8	Manchon de positionnement	BS 16 M10	-	1
9	Clé de réglage	AK 03	-	1
10	Clé hexagonale 4	HK 04	-	1
	Clé hexagonale 5	HK 05	-	1
	Clé hexagonale 6	HK 06	-	1
	Clé hexagonale 8	HK 08	-	1
11	Clé Torx 6	TK06	-	1
	Clé Torx 7	TK07	-	1
	Clé Torx 15	TK15	-	1
12	Vis de fixation de plaque	D 27 21	-	4
13	Vis de cartouche	CS 10 25	-	1
14	Vis de contrepoids	CS 08 25	-	1

Ø 8 – 210

RÉFÉRENCE:

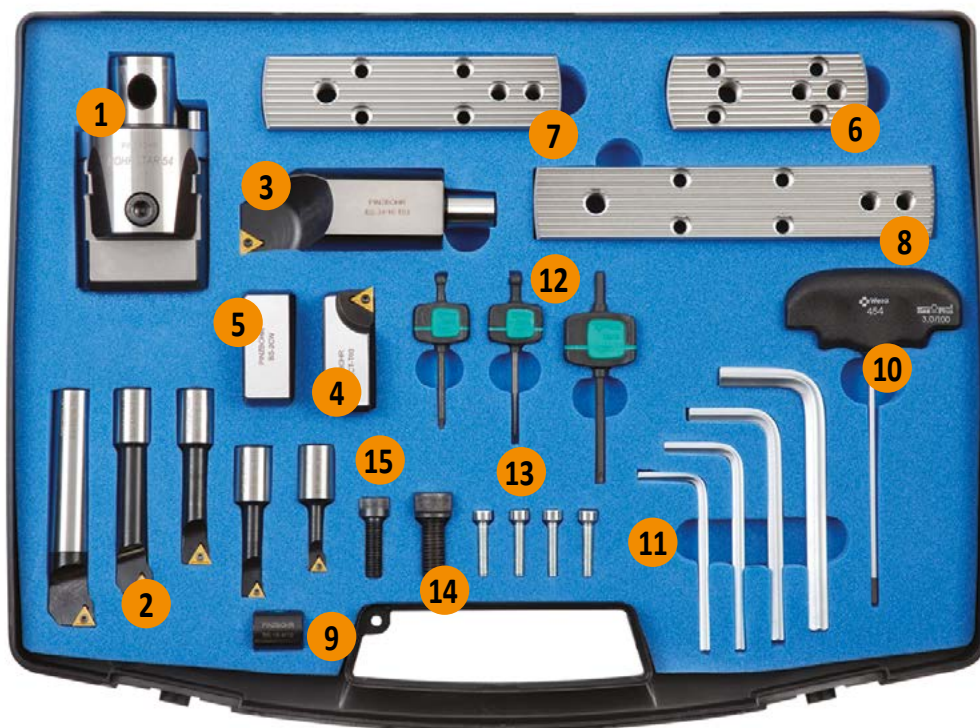

	Description	Marquage	Plaquette	Piè.
1	Tête d'alésage	BS 054 16	-	1
2	Barre d'alésage 6 mm	BS 06 16 T01	TC.. 06T1..	1
	Barre d'alésage 8 mm	BS 08 16 T01	TC.. 06T1..	1
	Barre d'alésage 10 mm	BS 10 16 T02	TC.. 0902..	1
	Barre d'alésage 12 mm	BS 12 16 T02	TC.. 0902..	1
	Barre d'alésage 16 mm	BS 16 16 T02	TC.. 0902..	1
3	Barre d'alésage 34 mm	BS 34 16 T04	TC.. 16T3..	1
4	Cartouche	BS 2CT T04	TC.. 16T3..	1
5	Contrepoids	BS 2CW	-	1
6	Petite plaque	BS SP 85 130	-	1
7	Plaque moyenne	BS SP 125 170	-	1
8	Large plate	BS SP 165 210	-	1
9	Manchon de positionnement	BS 16 M10	-	1
10	Clé de réglage	AK 03	-	1
11	Clé hexagonale 4	HK 04	-	1
	Clé hexagonale 5	HK 05	-	1
	Clé hexagonale 6	HK 06	-	1
	Clé hexagonale 8	HK 08	-	1
12	Clé Torx 6	TK06	-	1
	Clé Torx 7	TK07	-	1
	Clé Torx 15	TK15	-	1
13	Vis de fixation de plaque	D 27 21	-	4
14	Vis de cartouche	CS 10 25	-	1
15	Vis de contrepoids	CS 08 25	-	1



DORMER PRAMET



TOUJOURS CONNECTÉ

Pas de connexion wifi ou internet? La calculatrice d'usage fonctionne parfaitement même lorsque vous n'êtes pas connecté, ce qui vous assure qu'elle est toujours disponible quand vous en avez besoin. **Simply Reliable.**

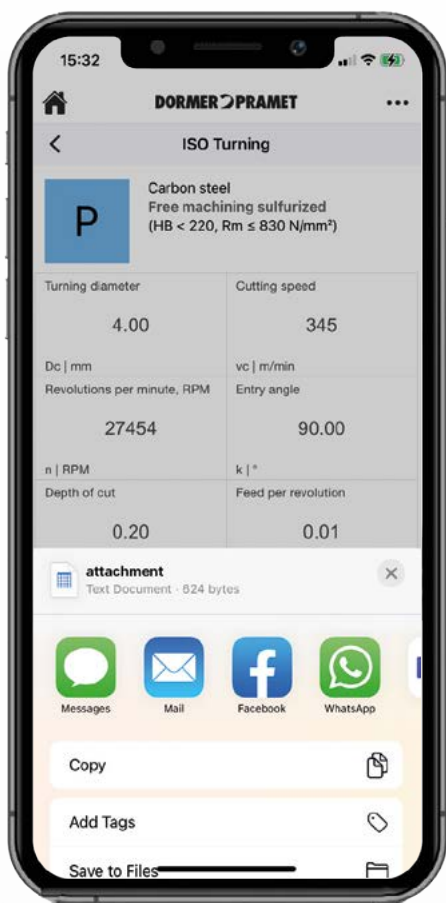



ALÉSAGE
INFORMATIONS TECHNIQUES



GROUPES DE MATÉRIAUX À USINER (WMG)

ISO Pour sélectionner une nuance et une géométrie convenant à une large gamme de matériaux à usiner

Définition générale
acier, acier inoxydable, etc.

P **M** **K** **N** **S** **H**

Sous-groupe Pour parcourir et choisir un outil adapté à une gamme plus spécifique de matériaux à usiner

Définition en fonction de la structure/composition
acier simple au carbone, acier spécial, etc.

P **M** **K** **N** **S** **H**

P1

P2

P3

P4

WMG Pour choisir et respecter des conditions de coupe données avec une marge de $\pm 10\%$

Définition en fonction de la dureté/résistance à la traction max.
160 < 220 HB, 620 < 900 n/mm²; etc.

P

P1 **P1.1** **P1.2** **P1.3**

P2 **P2.1** **P2.2** **P2.3**

P3 **P3.1** **P3.2** **P3.3**

P4 **P4.1** **P4.2** **P4.3**

À PROPOS DE LA CLASSIFICATION DES MATÉRIAUX À USINER DE DORMER PRAMET

Les groupes de matériaux à usiner (WMG pour Workpiece Material Groups) permettent de choisir plus facilement et en toute assurance le bon outil de coupe avec les valeurs de départ adaptées aux conditions d'un usinage particulier.

Dormer Pramet classe les matériaux à usiner en six groupes de couleurs différentes :

- **Bleu**: aciers et aciers moulés (groupe P)
- **Jaune**: aciers inoxydables (groupe M)
- **Rouge**: fontes (groupe K)
- **Vert**: métaux non ferreux (groupe N)
- **Brun** : alliages haute température (groupe S)
- **Gris**: matériaux durs (groupe H)

Chacun de ces groupes se divise en sous-groupes en fonction de la structure et/ou de la composition des matériaux. Par exemple, les aciers et aciers moulés du groupe P sont classés en quatre sous-groupes, comme suit :

- **P1: acier de décolletage**
- **P2: acier simple au carbone**
- **P3: acier allié**
- **P4: acier à outil**

Un dernier classement se fait en fonction des propriétés du matériau, comme sa dureté et sa résistance à la traction maximale. Nos clients peuvent ainsi choisir l'outil le mieux adapté à leur application et ils disposent des valeurs de vitesse de coupe et d'avance initiales.

Le tableau de la page suivante comprend une description de chaque groupe de matériaux à usiner ainsi que des exemples, avec des désignations courantes.



GROUPES DE MATÉRIAUX À USINER (WMG)

Groupes de matériaux à usiner (WMG)	k_{vc}	Exemples de matériaux (AISI, EN, DIN, ČSN, GB, SS, STN, BS, UNE, AFNOR, ASTM, GOST, UNS, UNI, etc.)
P1	P1.1	Acier de décolletage au carbone et manganèse d'une dureté < 240 HB
	P1.2	Acier de décolletage au carbone, manganèse et phosphore d'une dureté < 180 HB
	P1.3	Acier de décolletage au carbone, manganèse, phosphore et plomb d'une dureté < 180 HB
P2	P2.1	Acier simple à faible teneur en carbone < 0,25 % d'une dureté < 180 HB
	P2.2	Acier simple à teneur moyenne en carbone < 0,55 % d'une dureté < 240 HB
	P2.3	Acier simple à forte teneur en carbone < 0,55 % d'une dureté < 300 HB
P3	P3.1	Acier allié d'une dureté < 180 HB
	P3.2	Acier allié d'une dureté 180-260 HB
	P3.3	Acier allié d'une dureté 260-360 HB
P4	P4.1	Acier à outil d'une dureté < 26 HRC
	P4.2	Acier à outil d'une dureté 26-39 HRC
	P4.3	Acier à outil d'une dureté 39-45 HRC

P
Acier et acier moulé
(aciers avec une teneur en alliage ≤ 10 % et d'une dureté < 45 HRC)



GROUPES DE MATÉRIAUX À USINER (WMG)

Groupes de matériaux à usiner (WMG)	k _{vg}	Exemples de matériaux (AISI, EN, DIN, ČSN, GB, SS, STN, BS, UNE, AFNOR, ASTM, GOST, UNS, UNI, etc.)
M1 Acier inoxydable ferritique (alliages non durcissables au chrome droit)	M1.1	Acier inoxydable, ferritique d'une dureté < 160 HB 1.22
	M1.2	Acier inoxydable, ferritique d'une dureté 160-220 HB 1.03
	M2.1	Acier inoxydable, martensitique d'une dureté < 200 HB 1.08
M2 Acier inoxydable martensitique (alliages durcissables au chrome droit)	M2.2	Acier inoxydable, martensitique d'une dureté 200-280 HB 0.89
	M2.3	Acier inoxydable, martensitique d'une dureté 280-380 HB 0.75
	M3.1	Acier inoxydable, austénitique d'une dureté < 200 HB 1.00
M3 Acier inoxydable austénitique (alliages chrome-nickel et chrome-nickel-manganèse)	M3.2	Acier inoxydable, austénitique d'une dureté 200-260 HB 0.86
	M3.3	Acier inoxydable, austénitique d'une dureté 260-300 HB 0.77
	M4.1	Acier inoxydable, austénitique-ferritique ou super-austénitique d'une dureté < 300 HB 0.75
M4 Acier inoxydable super-austénitique (duplex) à durcissement par précipitation (alliages austénitiques > 20 % Ni, micro-structure austéno-ferritique ou durci par précipitation)	M4.2	Acier inoxydable, austénitique à durcissement par précipitation d'une dureté 300-380 HB 0.64

M
Acier inoxydable
(aciers résistants à la corrosion avec une teneur en chrome ≥ 11 %)



GROUPES DE MATÉRIAUX À USINER (WMG)

Groupes de matériaux à usiner (WMG)	k _{nc}	Exemples de matériaux (AISI, EN, DIN, ČSN, GB, SS, STN, BS, UNE, AFNOR, ASTM, GOST, UNS, UNI, etc.)
K1 Fonte grise (GG) (pièces moulées en fer-carbone avec micro-structure graphite lamellaire)	K1.1	Fonte grise, ferritique ou ferritique-perlitique d'une dureté < 180 HB
	K1.2	Fonte grise, ferritique-perlitique ou perlitique d'une dureté 180-240 HB
	K1.3	Fonte grise, perlitique d'une dureté 240-280 HB
K2 Fonte malléable (GTS/GTW) (pièces moulées en fer-carbone thermotraitée avec micro-structure sans graphite)	K2.1	Fonte malléable, ferritique d'une dureté < 160 HB
	K2.2	Fonte malléable, ferritique ou perlitique d'une dureté 160-200 HB
	K2.3	Fonte malléable, perlitique d'une dureté 200-240 HB
K3 Fonte malléable (GGG) (pièces moulées en fer-carbone avec micro-structure en graphite nodulaire)	K3.1	Fonte malléable (nodulaire/sphéroïdale), ferritique d'une dureté < 180 HB
	K3.2	Fonte malléable (nodulaire/sphéroïdale), ferritique ou perlitique d'une dureté 180-220 HB
	K3.3	ou perlitique, perlitique d'une dureté 220-260 HB
K4 Fonte malléable austénitique ou à trempe étagée (rés. Ni/ADI) (alliage fer-carbone avec micro-structure austénitique ou ausferritique)	K4.1	Fonte austénitique d'une dureté < 180 HB
	K4.2	Fonte austénitique d'une dureté 180-240 HB
	K4.3	Fonte malléable à trempe étagée d'une dureté 240-280 HB
	K4.4	Fonte malléable à trempe étagée d'une dureté 280-320 HB
	K4.5	Fonte malléable à trempe étagée d'une dureté 320-360 HB
K5 Fonte à graphite vermiculaire compactée (CGI) (pièces moulées en fer-carbone avec structure graphite vermiculaire)	K5.1	Fonte à graphite vermiculaire compactée d'une dureté < 180 HB
	K5.2	Fonte à graphite vermiculaire compactée d'une dureté 180-220 HB
	K5.3	Fonte à graphite vermiculaire compactée d'une dureté 220-260 HB



GROUPES DE MATÉRIAUX À USINER (WMG)

Groupes de matériaux à usiner (WMG)	k _{vg}	Exemples de matériaux (AISI, EN, DIN, ČSN, GB, SS, STN, BS, UNE, AFNOR, ASTM, GOST, UNS, UNI, etc.)
N1 Aluminium corroyé	N1.1	Aluminium pur et alliages d'aluminium moulés d'une dureté < 60 HB
	N1.2	Alliages d'aluminium corroyé d'une dureté 60-100 HB
	N1.3	Alliages d'aluminium corroyé d'une dureté 100-150 HB
N2 Aluminium moulé	N2.1	Alliages d'aluminium moulé d'une dureté < 75 HB
	N2.2	Alliages d'aluminium moulé d'une dureté 75-90 HB
	N2.3	Alliages d'aluminium moulé d'une dureté 90 < 140 HB
N3 Cuivre ou alliages de cuivre	N3.1	Alliages de cuivre de décolletage avec d'excellentes propriétés d'usinage
	N3.2	Alliages de cuivre à copeaux courts avec des propriétés d'usinage bonnes à moyennes
	N3.3	Alliages de cuivre à longs copeaux et cuivre électrolytique avec des propriétés d'usinage moyennes à moyennes
N4 Polymères (matériaux synthétiques ou semi-synthétiques)	N4.1	Polymères et thermoplastiques
	N4.2	Polymères thermodurcissables
	N4.3	Polymères renforcés ou composites
N5 Graphite	N5.1	



GROUPES DE MATÉRIAUX À USINER (WMG)

Groupes de matériaux à usiner (WMG)	k_{vc}	Exemples de matériaux (AISI, EN, DIN, ČSN, GB, SS, STN, BS, UNE, AFNOR, ASTM, GOST, UNS, UNI, etc.)
S1 Titane ou alliages de titane	S1.1	Titane ou alliages de titane d'une dureté < 200 HB 1.94
	S1.2	Alliages de titane d'une dureté 200-280 HB 1.72
	S1.3	Alliages de titane d'une dureté 280-360 HB 1.44
S2 Alliages à base de fer haute température	S2.1	Alliages à base de fer haute température d'une dureté < 200 HB 1.33
	S2.2	Alliages à base de fer haute température d'une dureté 200-280 HB 1.17
S3 Alliages à base de nickel haute température	S3.1	Alliages à base de nickel haute température d'une dureté < 280 HB 1.00
	S3.2	Alliages à base de nickel haute température d'une dureté 280-360 HB 0.83
S4 Alliages à base de cuivre haute température	S4.1	Alliages à base de cuivre haute température d'une dureté < 240 HB 0.78
	S4.2	Alliages à base de cuivre haute température d'une dureté 240-320 HB 0.67

Alliages haute température

(superalliages dont la résistance thermique et à la corrosion est supérieure à celle de l'acier inoxydable)

S



GROUPES DE MATÉRIAUX À USINER (WVG)

Groupe ISO	Sous-groupe	Groupes de matériaux à usiner (WVG)	k_{vg}	Exemples de matériaux (AISI, EN, DIN, ČSN, GB, SS, STN, BS, UNE, AFNOR, ASTM, GOST, UNS, UNI, etc.)
H Matériaux trempés (tout métal d'ingénierie ayant une dureté > 45 HRC)	H1 Fonte en coquille	H1.1 Fonte en coquille d'une dureté < 440 HB	1.52	UNS F45001, EN-GJS-1050-6, DIN 5.3406, SS 0512, BS Grade 2A
		H2.1 Fonte trempée d'une dureté < 55 HRC	0.90	UNS F45003, EN-GJS-1400-1, DIN 5.3405, SS 0457, BS Grade 3D
	H2 Fonte trempée	H2.2 Fonte trempée d'une dureté > 55 HRC	0.77	UNS F45003, EN G-X260NiCr4-2, DIN 0.9620, SS 0466, BS Grade S
		H3.1 Acier trempé d'une dureté < 51 HRC	1.00	AISI 4135, EN 34CrMo4, DIN 1.7220, SS 2234, STN 415131, BS 198, UNE F.1250, GB 35CrMo, AFNOR 35CD4, GOST AC38XTM, UNI 35CrMo4KB
	H3 Acier trempé < 55 HRC	H3.2 Acier trempé d'une dureté 51-55 HRC	0.82	AISI 4135, EN 34CrMo4, DIN 1.7220, SS 2234, STN 415131, BS 198, UNE F.1250, GB 35CrMo, AFNOR 35CD4, GOST AC38XTM, UNI 35CrMo4KB
		H4.1 Acier trempé d'une dureté 55-59 HRC	0.64	UNS T31501, EN 100MnCrW4, DIN 1.2510, SS 2140, STN 419413, BS B01, UNE F.5220, GB 9CrWMn, AFNOR 90MnWCrV5, GOST 9XBТ, UNI 95MnWCr5KU
	H4 Acier trempé > 55 HRC	H4.2 Acier trempé d'une dureté > 59 HRC	0.54	UNS T31501, EN 100MnCrW4, DIN 1.2510, SS 2140, STN 419413, BS B01, UNE F.5220, GB 9CrWMn, AFNOR 90MnWCrV5, GOST 9XBТ, UNI 95MnWCr5KU

GÉOMÉTRIE DE COUPE DES PLAQUETTES NÉGATIVES – DÉSIGNATION SERRAGE ISO P, M, D

FF

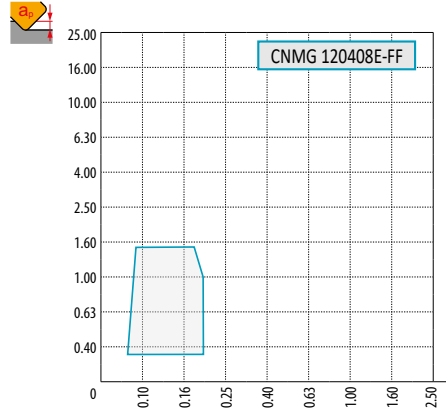
P	M	K	N	S	H
■	■	▣	■	■	■
f		0.06 – 0.25			
a _p		0.2 – 1.6			

? CNMG, DNMG, TNMG, VNMG, WNMG

FM

P	M	K	N	S	H
■	▣	■	■	▣	■
f		0.1 – 0.5			
a _p		0.4 – 5.0			

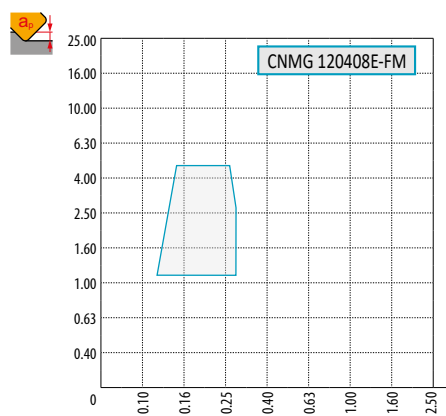
? CNMG, DNMG, SNMG, TNMG, VNMG, WNMG

M

P	M	K	N	S	H
■	■	■	■	■	▣
f		0.17 – 0.80			
a _p		0.8 – 8.0			

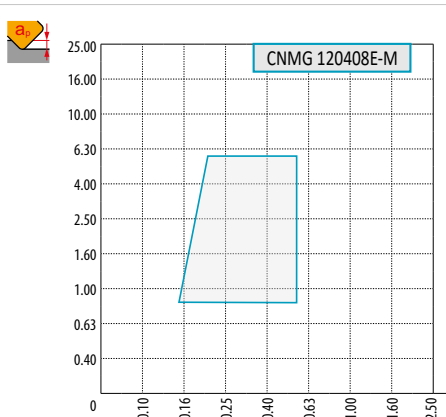
? CNMG, DNMG, SNMG, TNMG, VNMG, WNMG

NF

P	M	K	N	S	H
■	■	▣	▣	▣	■
f		0.1 – 0.35			
a _p		0.4 – 4.0			

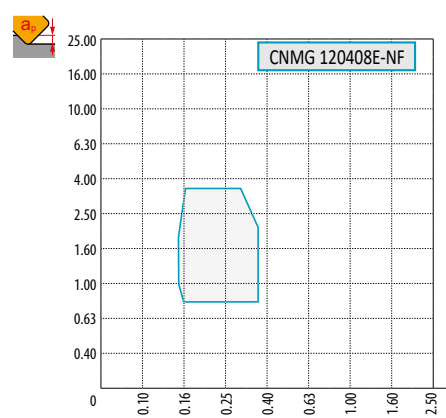
? CNMG, DNMG, SNMG, TNMG, VNMG, WNMG



GÉOMÉTRIE DE COUPE DES PLAQUETTES NÉGATIVES – DÉSIGNATION SERRAGE ISO P, M, D

NM



30° 0,25
10°

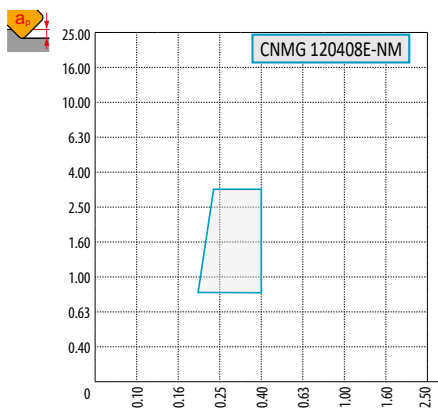

CNMG 120408E-NM

P	M	K	N	S	H
■	■	■	▣	■	■
f		0.15 – 0.55			
a _p		0.5 – 8.0			

?

CNMG, DNMG, TNMG, VNMG, WNMG

NMR



22° 0,31
10°

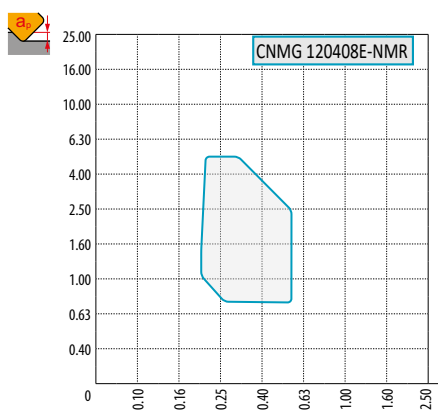

CNMG 120408E-NMR

P	M	K	N	S	H
■	■	■	▣	■	■
f		0.18 – 0.70			
a _p		0.4 – 8.0			

?

CNMG, DNMG, SNMG, TNMG, VNMG, WNMG

R



0,4
0,1 5° 15°
5°

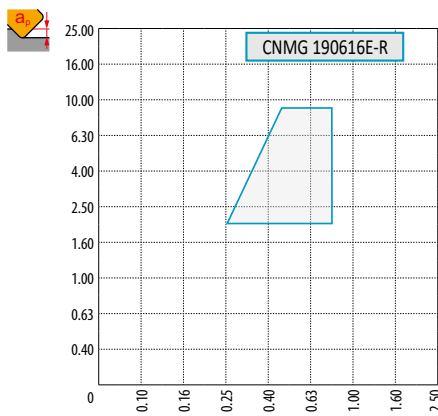

CNMG 190616E-R

P	M	K	N	S	H
■	■	■	▣	■	▣
f		0.25 – 0.80			
a _p		2.0 – 9.0			

?

CNMG, DNMG, SNMG, TNMG, WNMG

SF



1,94
14,5°

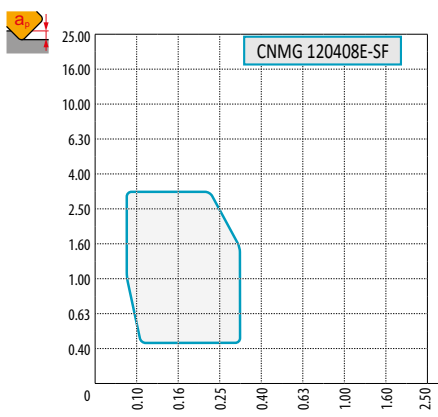

CNMG 120408E-SF

P	M	K	N	S	H
■	■	■	▣	■	■
f		0.08 – 0.35			
a _p		0.2 – 3.5			

?

CNMG, DNMG, SNMG, TNMG, VNMG, WNMG

GÉOMÉTRIE DE COUPE DES PLAQUETTES NÉGATIVES – DÉSIGNATION SERRAGE ISO P, M, D

SI



15°-18°

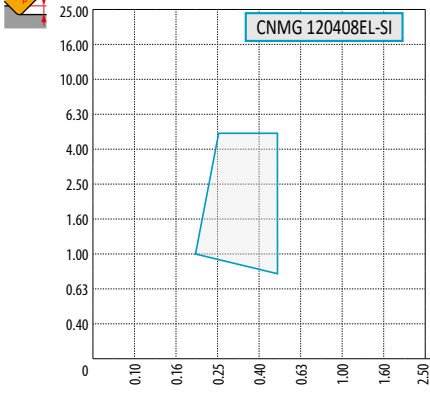

CNMG 120408EL-SI

P	M	K	N	S	H
■	■	■	▣	▣	▣
f	0.20 – 0.50				
a_p	0.8 – 5.0				



? CNMG, DNMG, TNMG, WNMG

SM



13° 0.25 5°

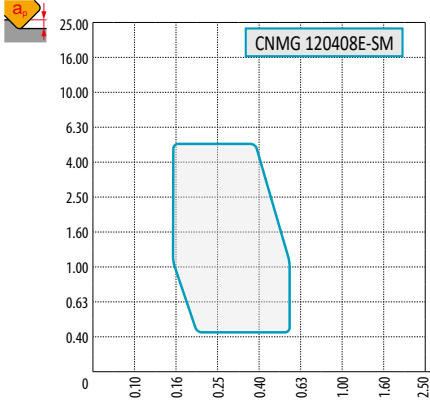

CNMG 120408E-SM



P	M	K	N	S	H
■	■	■	▣	■	▣
f	0.15 – 0.55				
a_p	0.4 – 6.0				





? CNMG, DNMG, SNMG, TNMG, VNMG, WNMG

GÉOMÉTRIE DE COUPE DES PLAQUETTES POSITIVES – DÉSIGNATION SERRAGE ISO S

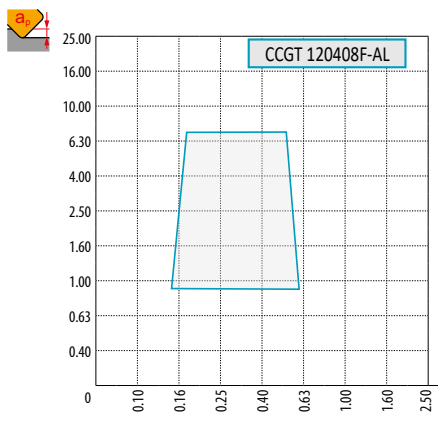

AL

P	M	K	N	S	H
			■	▣	
f	0.05 – 0.60				
a _e	0.2 – 7.0				
					
					
 CCGT, DCGT, SCGT, RCGT, TCGT, VCGT, WCGT					

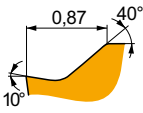
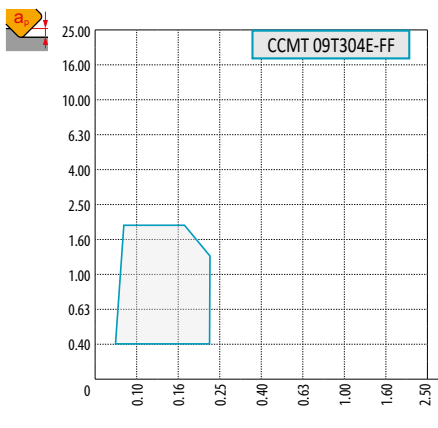

FF



P	M	K	N	S	H
■	▣				
f	0.05 – 0.23				
a _e	0.2 – 2.0				
					
					
 CCMT, DCMT					

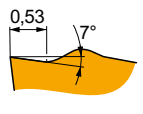
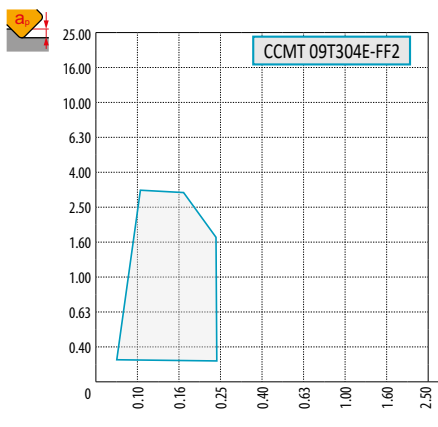

FF2

P	M	K	N	S	H
■		■			
f	0.02 – 0.28				
a _e	0.20 – 3.0				
					
					
 CCMT, CCGT, DCGT, DCMT, SCMT, TCGT, TCMT, VBMT, VCGT, VCGX, WCGT					

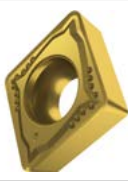
FM

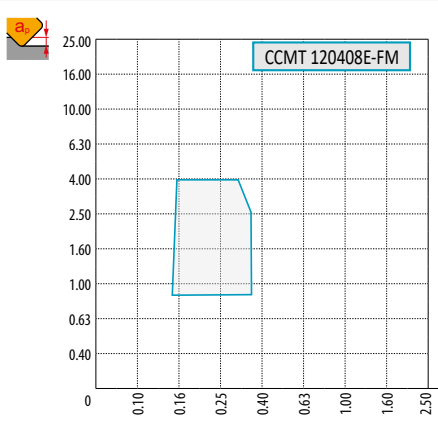
P	M	K	N	S	H
■	■	▣	▣		
f	0.05 – 0.45				
a _e	0.2 – 4.0				
					
					
 CCMT, DCMT, SCMT, TCMT, VBMT, WCMT					

GÉOMÉTRIE DE COUPE DES PLAQUETTES POSITIVES – DÉSIGNATION SERRAGE ISO S

FM2

P	M	K	N	S	H
■	▣	■	■	■	■

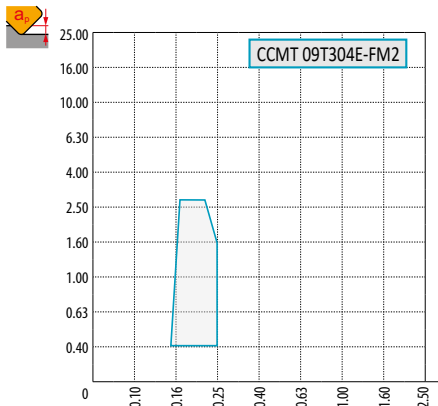
f 0.04 – 0.4

a_p 0.2 – 4.0



? CCMT, DCMT, ECMT, SCMT, TCMT, VBMT, VCGT

NF1

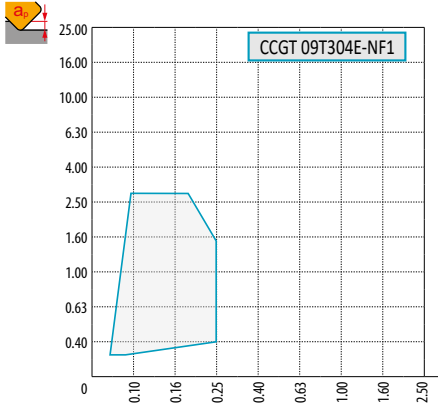
P	M	K	N	S	H
■	■	■	▣	■	▣

f 0.04 – 0.35

a_p 0.3 – 3.5



? CCGT, DCGT, SCGT, TCGT

NF2

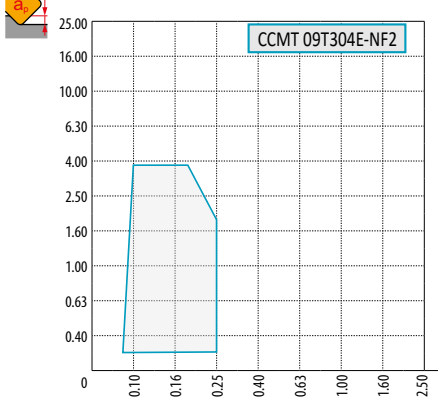
P	M	K	N	S	H
▣	■	▣	▣	■	■

f 0.05 – 0.45

a_p 0.2 – 4.0



? CCMT, EPMT, SCMT, TCMT, VCGT

RF



I. C.	R
6,35	1,0
9,525	1,5
12,7	2,5

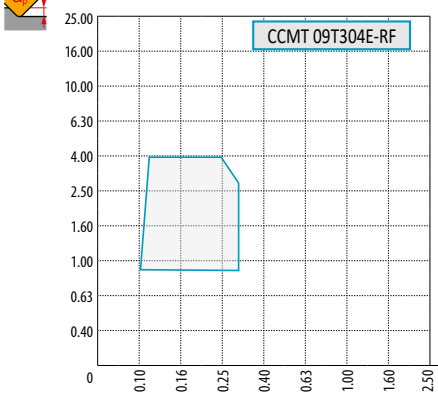

P	M	K	N	S	H
■	▣	■	■	■	▣

f 0.10 – 0.60

a_p 0.8 – 8.0







? CCMT, DCMT, SCMT, TCMT, WCMT



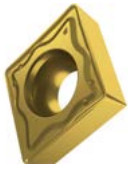
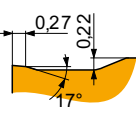

GÉOMÉTRIE DE COUPE DES PLAQUETTES POSITIVES – DÉSIGNATION SERRAGE ISO S



RM

P	M	K	N	S	H
■	■	■	■	■	■
f 0.10 – 0.50					
a _p 0.8 – 4.5					
					
					
 CCMT, DCMT, SCMT, TCMT, VBMT					

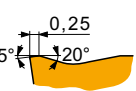

RM3

P	M	K	N	S	H
■	■	■	■	■	■
f 0.15 – 0.90					
a _p 0.4 – 6.00					
					
					
 CCMT, SCMT, TCMT, RCMT					

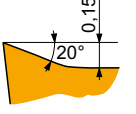
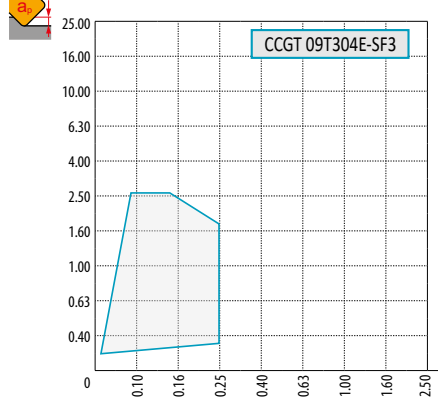

SF3

P	M	K	N	S	H
■	■	■	■	■	■
f 0.02 – 0.35					
a _p 0.2 – 4.00					
					
					
 CCGT, DCGT, ECGT, SCGT, TCGT, VCGT					

SI

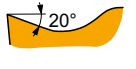
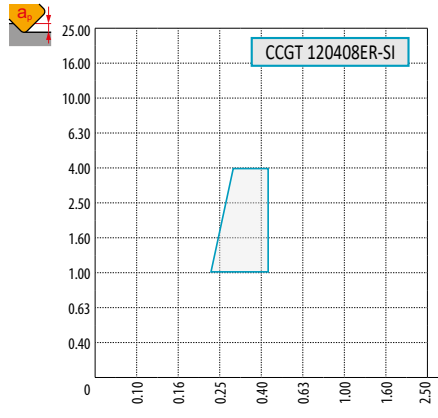



P	M	K	N	S	H
■	■	■	■	■	■
f 0.08 – 0.45					
a _p 0.4 – 4.0					
					
					
 CCGT, TCGT					

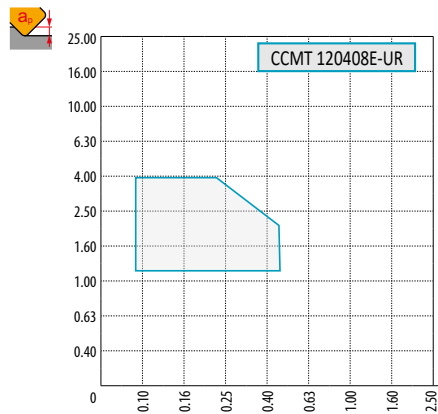
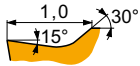
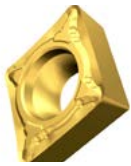

GÉOMÉTRIE DE COUPE DES PLAQUETTES POSITIVES – DÉSIGNATION SERRAGE ISO S

UR



P	M	K	N	S	H
■	▣	■	■	■	■
	0.10 – 0.40				
	1.0 – 4.0				
	CCMT, DCMT, RCMT, SCMT, TCMT, VCMT, VBMT, WCMT				

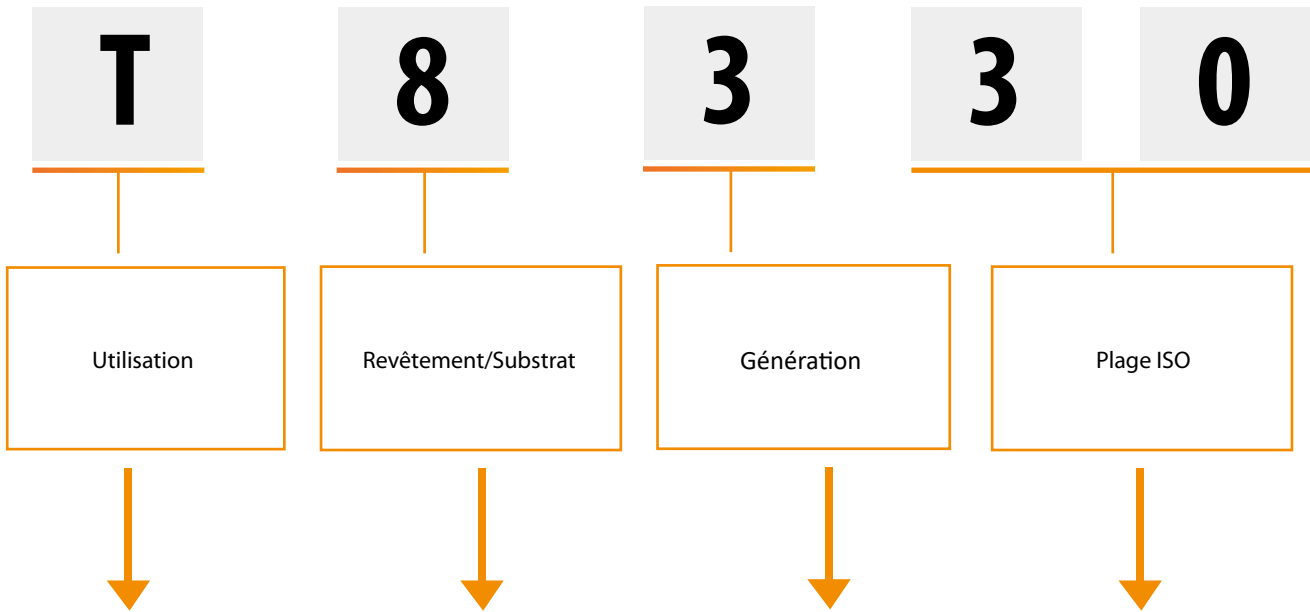

D	Perçage
M	Fraisage
T	Tournage
G	Tronçonnage et gorges

0 PVD 1 CVD	Application spéciale
2 PVD 3 CVD	Libre
4 PVD 5 CVD	Groupes K, H
6 PVD 7 CVD	Groupes M, S
8 PVD 9 CVD	Universel
B	CBN
C	Céramique
D	PCD
T	Cermet

1 - 9

01 - 50	
	01 - 05
	05 - 10
	10 - 20
	20 - 30
	30 - 40
	40 - 50



NUANCES PLAQUETTES D'ALÉSAGE

Identification de la nuance	Domaine d'application	Application	Avance	Vitesse de coupe	Résistance en conditions de travail compliquées	Revêtement	Couleur	Substrat	Bénéfice arrosage	Description de la nuance
T9315	P05 - P25	■				MT-CVD		FGM	++	Une nuance polyvalente avec d'excellentes propriétés de résistance à l'usure, même dans des conditions de coupe intenses. Elle convient également aux opérations de coupes interrompues. Avec des propriétés équilibrées, cette nuance est un excellent choix pour une large gamme d'opérations de tournage. Elle ne convient pas pour des opérations à vitesse de coupe lente.
	K05 - K25	▣	▣	▣						
	H10 - H20	▣								
T9325	P15 - P35	■				MT-CVD		FGM	++	D'un point de vue technologique, il s'agit d'une nuance extrêmement polyvalente. Présentant une résistance élevée aux dommages mécaniques dans des conditions de coupe difficiles, elle conserve une excellente résistance à l'usure. Cette nuance nécessite des vitesses de coupe élevées.
	M10 - M30	▣	▣	▣						
	K15 - K35	▣								
	S10 - S20	▣								
T9335	P20 - P45	■				MT-CVD		FGM	+++	L'une des nuances les plus résistantes ; elle est particulièrement adaptée aux conditions de coupe difficiles, à des avances moyennes à élevées et à des vitesses de coupe moyennes. Par rapport à ses prédécesseurs (M15 – M40), elle est non seulement plus robuste, mais aussi plus résistante à l'abrasion. Elle convient donc aux conditions de coupe intenses.
	M15 - M40	▣	▣	▣						
	S15 - S25	▣								
T7325	P15 - P35	▣				MT-CVD		FGM	+++	L'une des nuances de tournage les plus universelles. Spécialement conçue pour l'usinage de l'acier inoxydable. Elle offre un équilibre optimal entre résistance à l'usure et fiabilité des performances. Elle convient à une grande variété d'applications de tournage.
	M10 - M25	▣	▣	▣						
	S10 - S25	▣								
T7335	P20 - P40	▣				MT-CVD		FGM	+++	Nuance avec substrat à gradient fonctionnel, présentant une très grande fiabilité opérationnelle et une très bonne résistance à l'usure. Elle convient parfaitement à l'usinage de matériaux très tenaces de type M20 – M40.
	M20 - M40	▣	▣	▣						
	S15 - S25	▣								
T5305	P05 - P15	▣				MT-CVD		H	+	Nuance présentant une très haute résistance à l'usure chimique ; elle convient aux opérations de finition à vitesse de coupe élevée. Grâce à sa grande résistance à l'abrasion, elle est également adaptée à l'usinage productif de matériaux trempés et traités, K01 – K15.
	K01 - K15	▣	▣	▣						
	H05 - H15	▣								
T5315	P10 - P25	▣				MT-CVD		H	+	Nuance destinée principalement à des usinages productifs. Elle présente une résistance élevée à l'abrasion et une bonne fiabilité opérationnelle. Grâce à ses propriétés, elle est particulièrement adaptée aux opérations d'ébauche et de finition dans des conditions de coupe bonnes à légèrement défavorables.
	K10 - K25	▣	▣	▣						
	H15 - H25	▣								
T0315	N05 - N20	■	▣	▣	▣	PVD			++	Nuance submicronique pour le tournage des métaux non ferreux et de leurs alliages, offrant un équilibre entre résistance à l'usure et ténacité. Elle est dotée d'un revêtement unique présentant d'excellentes propriétés anti-frottement.
T6310	P01 - P15	■				PVD		ultra submicron H	+++	Nuance de tournage hautement résistante à l'usure avec revêtement de surface PVD. Elle convient aux opérations de finition et aux applications pour lesquelles une arête de coupe aiguisée et une résistance élevée à l'usure en dépouille sont d'une grande importance.
	M01 - M15	▣	▣	▣						
	K05 - K20	▣								
	N05 - N20	▣								
	S01 - S15	▣								
T8315	P05 - P20	▣				PVD		submicron H	++	Offrant une excellente résistance à l'abrasion tout en maintenant une fiabilité opérationnelle supérieure à la moyenne, cette nuance est adaptée aux usinages à des vitesses de coupe moyennes à élevées dans des matériaux durs à copeaux courts.
	M05 - M20	▣	▣	▣						
	K05 - K25	▣								
	N05 - N25	▣								
	S05 - S15	▣								



NUANCES PLAQUETTES D'ALÉSAGE

Identification de la nuance	Domaine d'application	Application	Avance	Vitesse de coupe	Résistance en conditions de travail compliquées	Revêtement	Couleur	Substrat	Bénéfice arrosage	Description de la nuance
T8330	P25 - P40	■				PVD	■	submicron H	+++	Sans aucun doute le matériau de coupe le plus polyvalent : cette nuance convient à l'usinage de tous les types de matériaux et pratiquement à tous les types d'opérations de tournage. Ses principaux avantages sont sa grande fiabilité opérationnelle et ses très bonnes propriétés anti-frottement ; elle convient donc aux applications à des vitesses de coupe moyennes et basses.
	M20 - M35	■								
	K20 - K40	■								
	N15 - N30	■								
	S15 - S25	■								
	H15 - H25	■								
T8430	P20 - P40	■				PVD	■	submicron H	+++	Sans aucun doute le matériau de coupe le plus polyvalent : cette nuance convient à l'usinage de tous les types de matériaux et pratiquement à tous les types d'opérations de tournage. Ses principaux avantages sont sa grande fiabilité opérationnelle et ses très bonnes propriétés anti-frottement ; elle convient donc aux applications à des vitesses de coupe moyennes et basses.
	M20 - M35	■								
	K25 - K40	■								
	N15 - N30	■								
	S15 - S25	■								
	H15 - H25	■								
HF7	M10 - M20	■				×	■	submicron H	++	Nuance non revêtue qui est principalement destinée à l'usinage des métaux non ferreux ; elle convient également à d'autres matériaux usinés (sauf l'acier). Ce matériau peut être utilisé pour le tournage, le fraisage et même l'alésage.
	K10 - K25	■								
	N10 - N25	■								
H07	M05 - M15	■				×	■	submicron H	++	Nuance de tournage non revêtue convenant aux applications d'usinage où la résistance à l'oxydation n'est pas le critère dominant de la durée de vie de l'outil. Elle est conçue pour l'usinage d'alliages de Ti. Cette nuance présente une résistance élevée de l'arête de coupe ainsi qu'une bonne résistance à l'usure.
	K10 - K25	■								
	N10 - N30	■								
	S01 - S20	■								
TT310	P10 - P25	■				PVD	■	Cermet	+ / -	Cermet revêtu utilisé pour le tournage de précision et de finition des aciers au carbone et alliés (y compris les aciers inoxydables). Ses excellentes propriétés anti-frottement sont encore améliorées par le revêtement de type PVD.
	M15 - M25	■								
TT010	P01 - P10	■				×	■	Cermet	+ / -	Cermet non revêtu qui convient à l'usinage fin de tous les types d'acier (y compris l'acier inoxydable) à des vitesses d'avance très faibles. Son principal avantage est le rayon minime de l'arête de coupe et sa grande résistance à l'usure physique et à l'usure chimique.
	M01 - M10	■								
PD1	N05 - N25	■				×	■	PCD	--	La nuance PKD convient au tournage des métaux non ferreux. C'est un choix idéal pour travailler à des vitesses de coupe élevées et avance faible dans des conditions de travail stables.
TB310	K01 - K10	■				×	■	CBN	--	Nuance CBN pour l'usinage de matériaux trempés. Elle convient aux usinages à des vitesses de coupe élevées et avance faible dans des conditions de travail stables.
	S05 - S10	■								
	H01 - H10	■								

Substrat

H	Substrat de base WC-Co
submicron H	Substrat à grains fins base WC-Co (< 1 µm)
ultra submicron H	Substrat à grains très fins base WC-Co (< 0,5 µm)
FGM	Substrat gradient fonctionnel
Cermet	Carbure cémenté sans WC
PCD	Diamant polycristallin
CBN	Nitrure de Bore cubique

Revêtement

MT-CVD	Méthode de revêtement par dépôt chimique à moyenne température
PVD	Méthode de revêtement par dépôt physique à basse température
×	Nuance non revêtue

Bénéfices de l'arrosage

+++	L'utilisation de l'arrosage est essentielle
++	Arrosage fortement recommandé
+/-	L'arrosage peut être une option
--	Ne pas utiliser l'arrosage



TABLEAU DES CONDITIONS DE COUPE POUR L'ALÉSAGE

Les plaquettes de tournage standard sont utilisées avec des outils à aléser, mais les conditions recommandées pour le tournage ne s'appliquent pas ici (données indiquées sur les boîtes). Veuillez donc sélectionner les conditions de coupe selon le tableau suivant.

Matériau	Alésage de finition (avec une plaquette)				Alésage d'ébauche (avec deux plaquettes)								
	Diamètre	Vitesse de coupe v_c	Avance f_z	Profondeur de coupe a_p	Diamètre	Vitesse de coupe v_c	Avance f_z	Prof. de coupe max a_p					
P	24 – 30	110 – 140	0.05 – 0.15	0.05 – 0.30	24 – 30	110 – 140	0.15 – 0.25	4.2					
	29 – 40				105 – 140				0.15 – 0.30	5.7			
	39 – 50										105 – 150	0.20 – 0.30	6.3
	49 – 102	0.25 – 0.35											
	100 – 220		0.30 – 0.40										
	220 – 500												
M	24 – 30	70 – 110	0.07 – 0.15	0.12 – 0.35	24 – 30	69 – 90	0.12 – 0.20	4.2					
	29 – 40				80 – 110				0.10 – 0.20	0.20 – 0.50	70 – 100	0.15 – 0.25	5.7
	39 – 50												
	49 – 102												
	100 – 220												
	220 – 500												
K	24 – 30	70 – 110	0.07 – 0.15	0.12 – 0.35	24 – 30	60 – 110	0.20 – 0.30	4.2					
	29 – 40				80 – 115				0.20 – 0.50	70 – 100	0.25 – 0.35	5.7	
	39 – 50												0.12 – 0.20
	49 – 102												
	100 – 220												
	220 – 500												
N	24 – 30	150 – 300	0.05 – 0.15	0.12 – 0.35	24 – 30	120 – 300	0.20 – 0.30	4.2					
	29 – 40				150 – 360				0.10 – 0.20	0.20 – 0.50	150 – 370	0.25 – 0.35	5.7
	39 – 50												
	49 – 102												
	100 – 220												
	220 – 500												
S	24 – 30	30 – 40	0.07 – 0.15	0.12 – 0.35	24 – 30	25 – 35	0.12 – 0.20	4.2					
	29 – 40				30 – 45				0.20 – 0.50	30 – 40	0.15 – 0.25	5.7	
	39 – 50												0.10 – 0.20
	49 – 102												
	100 – 220												
	220 – 500												
H	24 – 30	30 – 40	0.07 – 0.15	0.12 – 0.35	24 – 30	25 – 35	0.12 – 0.20	4.2					
	29 – 40				30 – 45				0.20 – 0.50	30 – 40	0.15 – 0.25	5.7	
	39 – 50												0.10 – 0.20
	49 – 102												
	100 – 220												
	220 – 500												

INSTRUCTIONS D'UTILISATION

Instructions de réglage – têtes d'ébauche

- Équiper l'outil de plaquettes neuves.
- Déserrer la/les vis de blocage du coulisseau et la/les serrer très légèrement.
- Tourner la vis de réglage pour déplacer le coulisseau en dessous du diamètre visé.
- Inverser la rotation de la vis de réglage pour positionner le coulisseau au diamètre visé.
- Le réglage peut s'effectuer l'outil monté sur la machine, hors de la machine ou sur un banc de pré-réglage.
- Serrer la/les vis de fixation sur un banc de pré-réglage.

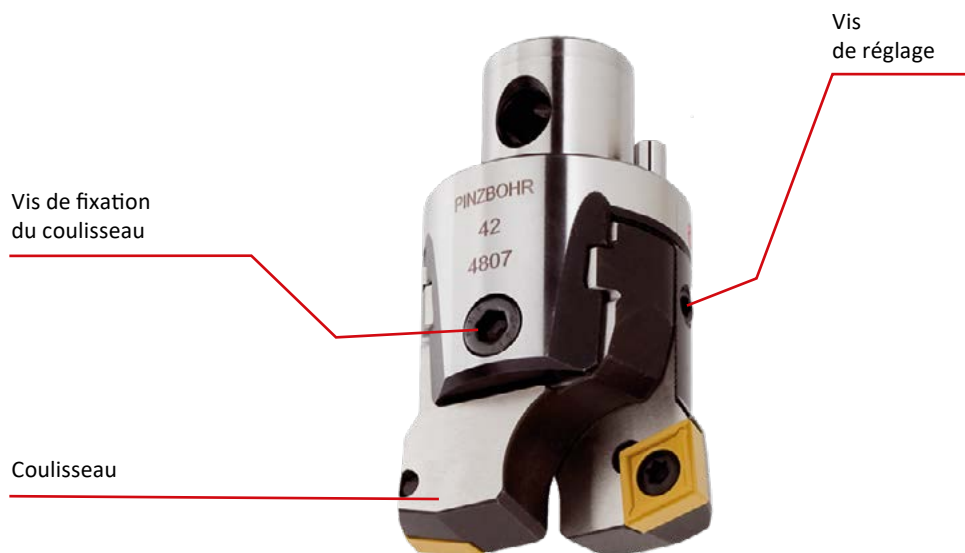

Pour les têtes de 68 et plus (à cartouches)

- Les cartouches ont des vis individuelles de réglage radial.
- Desserrer la vis de fixation de l'une des deux cartouches.
- En tournant la vis de réglage micrométrique, positionner le cartouche jusqu'à ce que les 2 plaquettes soient centrées ($R1 = R2$).

Instructions de réglage – têtes de finition

- Toutes les têtes de finition et de micro-alésage possèdent un réglage micrométrique avec une graduation de 0.002 mm.
- Équiper l'outil de plaquettes neuves.
- Le réglage doit être fait de préférence au comparateur ou sur un banc de pré-réglage.
- Desserrer la/les vis de blocage du coulisseau et la serrer très légèrement.
- Tourner la vis de réglage pour déplacer le coulisseau en dessous du diamètre visé.
- Inverser la rotation de la vis de réglage pour positionner le coulisseau en alignement de la pointe de la plaquette au diamètre visé.
- Serrer la/les vis de fixation.
- Pour les applications qui nécessitent une tolérance de trou particulière et difficile à obtenir, nous recommandons de régler la tête à un diamètre légèrement inférieur, de réaliser un alésage et de le mesurer. Ensuite régler de nouveau la valeur d'écart mesurée en utilisant le micromètre de la tête et faire une nouvelle passe.



Choix de l'angle d'attaque

75°



- Trous débouchants
- Ébauche lourde avec des avances élevées
- Tendance à suivre le trou existant
- Trous profonds - outils d'alésage longs (l'auto-centrage facilite l'entrée!)

90°



- Trous borgnes
- Alésages étagés avec épaulements à 90°
- Trous peu profonds - outils d'alésage courts (redresser et repositionner les trous décalés)
- Alésage avec cartouches décalés (taille 68 et plus)

Ces types de têtes d'alésage peuvent être équipées avec un cartouche symétrique et un cartouche décalé. Notez que les cartouches décalés ont la lettre "S" à la fin de leur désignation.

Exemples: 2CT 90 402 N S; 2CT 90 300 S; 2CT 90 402 S.

Alésage symétrique

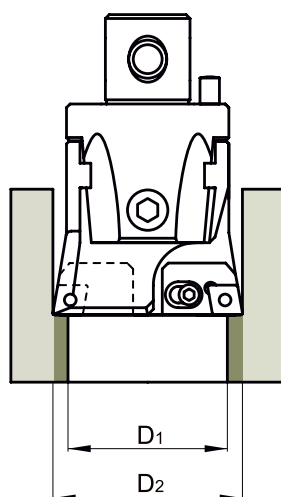

2CT □□ □□□ + 2CT □□ □□□
3CT □□ □□□ + 3CT □□ □□□

Alésage décalé

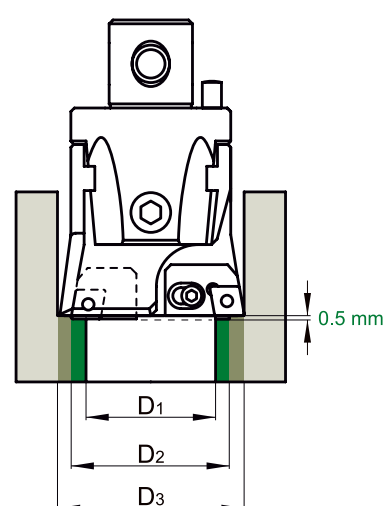

2CT □□ □□□ S + 2CT □□ □□□
3CT □□ □□□ S + 3CT □□ □□□

L'alésage décalé permet d'enlever plus de matière en une passe entre les diamètres D1 et D3, approximativement 4 à 6 mm comparé avec l'alésage symétrique.

Notez que pour l'alésage décalé l'avance par minute doit être calculée comme pour un outil ayant **une seule dent**.

SYSTÈME D'ASSEMBLAGE POUR GRANDES TÊTES À ALÉSER

Attention: Pendant le processus de montage, la vis de blocage (pos. 2) doit être desserrée.

Mise en place de la grande tête à aléser sur le mandrin

Retirer les vis de positionnement (pos. 1) pousser les coulisseaux jusqu'à ce que les quatre vis d'assemblage apparaissent. Assembler la face de mandrin avec les quatre vis sur l'arrière de la tête, puis installer et serrer les 4 vis d'assemblage.

FINITION

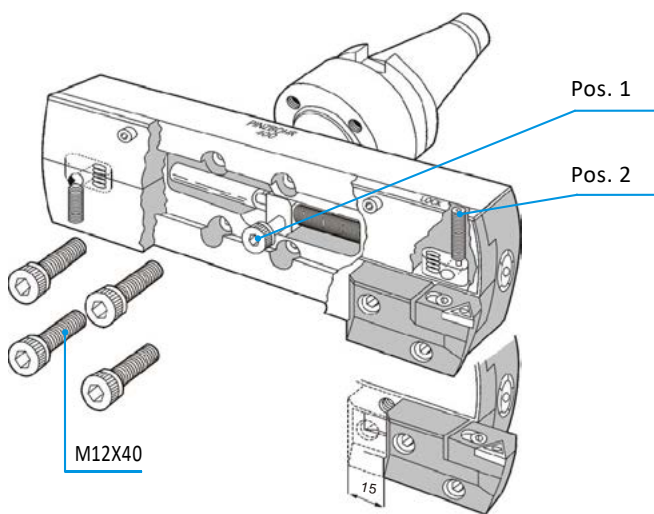

Vitesses et avances

Les vitesses et les avances ultimes ou optimales dépendront de la matière à enlever, de la machine et des conditions de réglage, ainsi que du porte-à-faux de l'outil.

Profondeur d'alésage – porte-à-faux de l'outil pour l'ébauche et la finition

Dans les conditions indiquées pour des outillages en carbure on peut atteindre des profondeurs de $5 \times \varnothing$ pour l'alésage d'ébauche et $3 \times \varnothing$ pour l'alésage de finition fine. En augmentant le porte-à-faux, la stabilité mécanique du corps de l'outil diminue. Les outils de grande longueur auront une tendance à la déviation et à une vibration harmonique. Une vibration harmonique peut provoquer le déplacement des composants réglés dans la tête à aléser avec pour conséquence un trou hors-dimension ou conique. Dans beaucoup de cas la vibration harmonique peut être atténuée en augmentant l'avance et/ou en diminuant la vitesse de coupe.

Notez que le comportement de la tête à aléser changera aussi lorsqu'on écartera les coulisseaux. Il faudra alors ajuster la vitesse de coupe et l'avance.

Profondeur d'alésage - porte-à-faux de l'outil pour les têtes de micro-alésage

La profondeur maximum d'alésage avec des barres d'alésage en acier ne devrait pas dépasser 5 fois le diamètre de la barre et 7 fois le diamètre pour les barres d'alésage en carbure. Nous recommandons de réduire au maximum le porte-à-faux de la barre conformément à la profondeur d'alésage exigée.

Pour une ébauche lourde on devra sélectionner le plus grand rayon de plaquette possible, sauf cas spécifiques.

Pour un alésage de finition avec un faible enlèvement de matière, le plus petit rayon de plaquette disponible est plus avantageux pour mi-450

Installation des coulisseaux sur la tête

Insérer les deux coulisseaux dans les guides en V, les pousser jusqu'à les aligner avec les trous filetés d'écrou. Mettre en place les vis (pos. 1) et serrer fermement. Ces vis ont une double fonction, car elles fixent le coulisseau dans les guides en V et relient le coulisseau et l'écrou en bronze. Enfin, vérifier que le coulisseau (coulisseaux d'ébauche) glisse doucement.

ÉBAUCHE

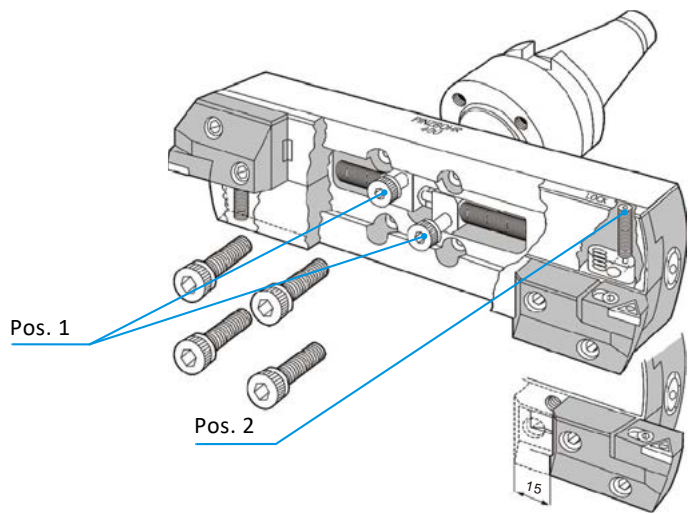

minimiser la déviation latérale de l'outil. Ceci est d'autant plus important pour des applications avec des porte-à-faux très longs.

Tête pour alésage d'ébauche à 75° vs 90°

La tête pour alésage d'ébauche à 75° devra être utilisée lorsqu'on devra enlever beaucoup de matière et quand le trou borgne ou étagé ne comprendra aucun épaulement.

La tête à 75° aura tendance à s'auto-centrer dans le trou pré-existant et, par conséquent, coupera de façon stable. Si le trou pré-existant est désaxé, il est alors recommandé d'utiliser la tête à aléser à 90° car l'angle d'attaque à 90° aura moins tendance à suivre le trou pré-existant.

Quantité d'enlèvement de matière

La quantité maximum de matière à enlever en alésage d'ébauche devra être diminuée dans les matériaux tenaces, des porte-à-faux ou des écartements de coulisseaux importants.

Rayon de pointe de la plaquette

Pour une ébauche lourde on devra sélectionner le plus grand rayon de plaquette possible, sauf cas spécifiques.

Pour un alésage de finition avec un faible enlèvement de matière, le plus petit rayon de plaquette disponible est indiqué pour minimiser la déviation latérale de l'outil. Ceci est d'autant plus important pour des applications avec des porte-à-faux très longs.

4 arêtes de coupe par plaquette

La plaquette rhombique à 80° possède normalement deux arêtes de coupe. Cependant on peut utiliser les 4 arêtes si l'on utilise des têtes pour alésage lourd à 75° et à 90° dans la même gamme de dimensions. La même chose est possible entre une tête pour alésage lourd à 75° et une tête pour alésage léger à 90°.

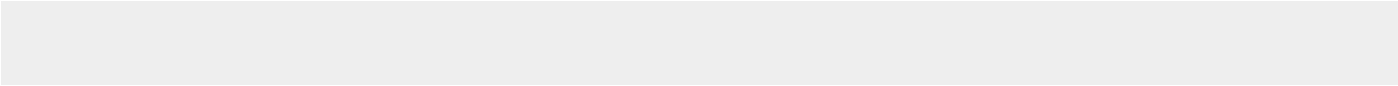

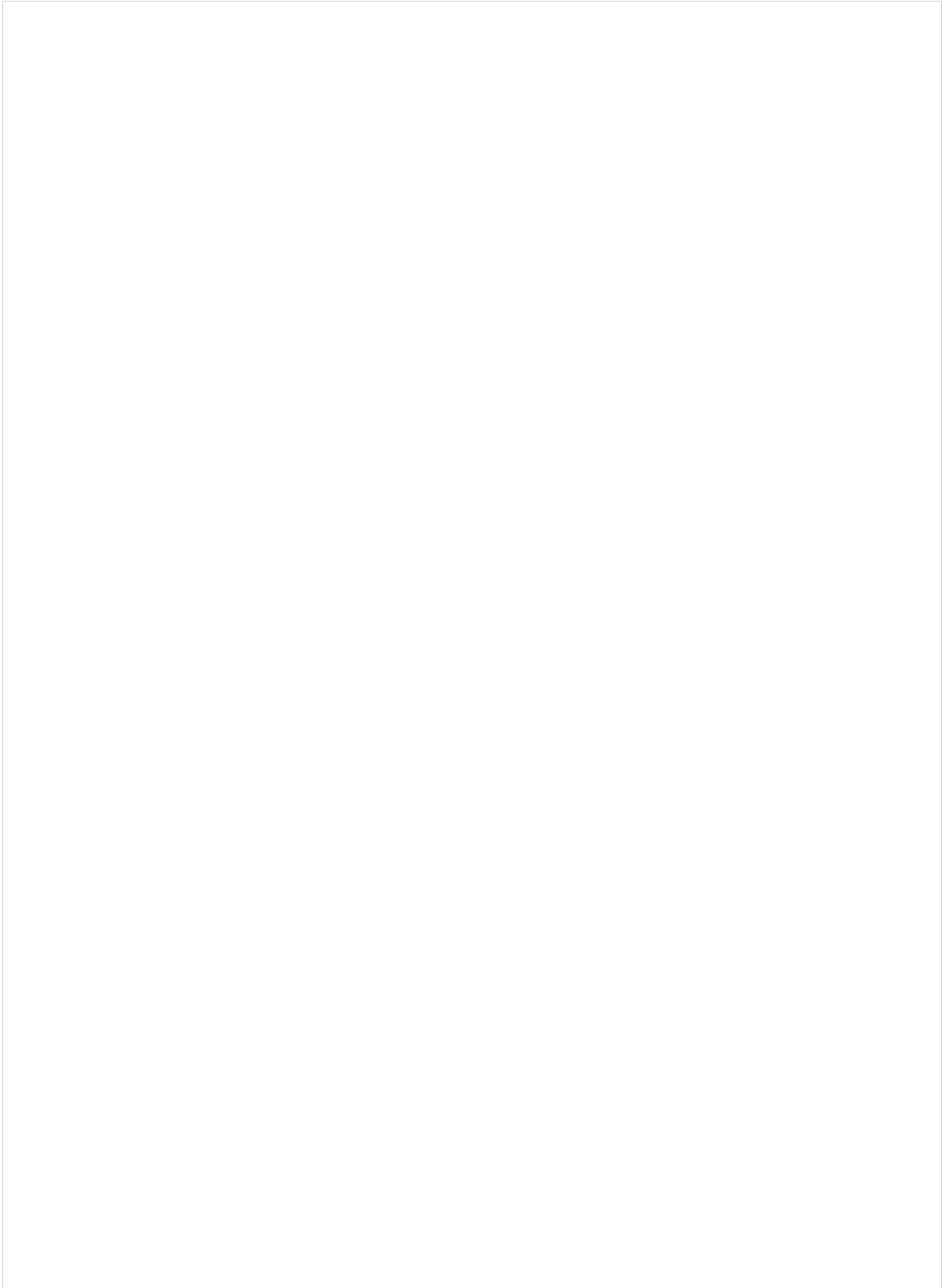
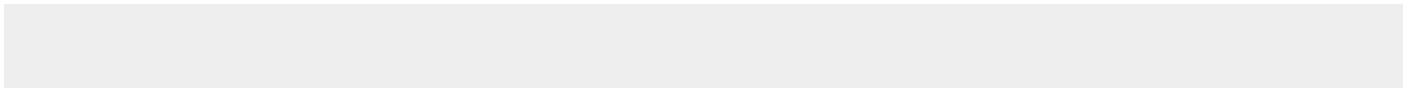

SIMPLY RELIABLE

Un copeau peut vous raconter une histoire de part sa forme et son fractionnement. En tant que professionnel, vous pouvez juger de la qualité d'un usinage rien qu'en le regardant. Le copeau envoie un message clair et évident, c'est pourquoi nous l'avons choisi comme symbole, **efficace tout simplement.**

DORMER PRAMET

Austria

T: +31 10 2080 240
info.at@dormerpramet.com

Belgium & Luxembourg

T: +32 3 440 59 01
info.be@dormerpramet.com

Brazil

T: +55 11 5660 3000
info.br@dormerpramet.com

Canada

T: (888) 336 7637
En Français: (888) 368 8457
cs.canada@dormerpramet.com

China

T: +86 21 2416 0508
info.cn@dormerpramet.com

Croatia

T: +385 98 407 489
info.hr@dormerpramet.com

Czech Republic

T: +420 583 381 111
info.cz@dormerpramet.com

Denmark

T: 808 82106
info.se@dormerpramet.com

Finland

T: 0205 44 7003
info.fi@dormerpramet.com

France

T: +33 (0)2 47 62 57 01
info.fr@dormerpramet.com

Germany

T: +49 9131 933 08 70
info.de@dormerpramet.com

Hungary

T: +36-96 / 522-846
info.hu@dormerpramet.com

India

T: +91 11 4601 5686
info.in@dormerpramet.com

Italy

T: +39 02 30 70 54 44
info.it@dormerpramet.com

Kazakhstan

T: +7 771 305 11 45
info.kz@dormerpramet.com

Mexico

T: +52 (555) 7293981
cs.mexico@dormerpramet.com

Netherlands

T: +31 10 2080 240
info.nl@dormerpramet.com

Norway

T: 800 10 113
info.se@dormerpramet.com

Poland

T: +48 32 78-15-890
info.pl@dormerpramet.com

Portugal

T: +351 21 424 54 21
info.pt@dormerpramet.com

Romania

T: +4(0)730 015 885
info.ro@dormerpramet.com

Russia

T: +7 (495) 775 10 28
info.ru@dormerpramet.com

Slovakia

T: +421 (41) 764 54 60
info.sk@dormerpramet.com

Slovenia

T: +385 98 407 489
info.si@dormerpramet.com

Spain

T: +34 935717722
info.es@dormerpramet.com

Sweden

responsible for Iceland
T: +46 35 16 52 96
info.se@dormerpramet.com

Switzerland

T: +31 10 2080 240
info.ch@dormerpramet.com

Turkey

T: +90 533 212 45 47
info.tr@dormerpramet.com

Ukraine

T: +38 067 566 38 80
T: +38 067 566 81 51
info.ua@dormerpramet.com

United Kingdom

responsible for Ireland
T: 0870 850 4466
info.uk@dormerpramet.com

United States of America

T: (800) 877-3745
cs@dormerpramet.com

Other countries

South America

T: +55 11 5660 3000
info.br@dormerpramet.com

Adria

T: +420 583 381 527
info.rcee@dormerpramet.com

Rest of the World

Dormer Pramet International UK
T: +44 1246 571338
info.int@dormerpramet.com

Dormer Pramet International CZ
T: +420 583 381 520
info.int.cz@dormerpramet.com

DP-CAT-HOLEMAKING-2021-FR

FOLLOW US...



www.dormerpramet.com



youtube.com/dormerpramet



facebook.com/dormerprametsocial



linkedin.com/company/dormerpramet



instagram.com/dormerprametsocial



twitter.com/dormerpramet