

EUROMAC



V.01 CATALOGUE COFFRETS
IMPRESSION 3D PERSONNALISEE

COFFRETS D'OUTILS

Sets - Juegos - Assortimenti - Sätze



Coffrets conçus par Euromac et imprimés en 3D en France à partir de matériaux renouvelables. Photos non-contractuelles.

EN : Boxes designed by Euromac and 3D-printed in France from renewable materials. Non-contractual photographs.

ES : Cajas diseñadas por Euromac e impresas en 3D en Francia. Fotografías no contractuales.

IT : Scatole concepite da Euromac e stampate in 3D in Francia con materiali rinnovabili. Fotografie non contrattuali.

DE : Von Euromac hergestellt und in Frankreich mit erneuerbaren Materialien 3D-gedruckte Schachteln. Nicht vertragliche Fotografien.

COFECHO-5	Fraises/Endmills/Fresas/Frese/Schaftfräser <i>Carbure/Carbide/VHM/MD - 5 dimensions</i>	Page 3
COF210-8	Alésoirs/Reamers/Escariadores/Alesatori/Reibahlen <i>HSS-E cobalt - DIN 212 - 8 dimensions H7</i>	Page 4
COF212-30	Alésoirs/Reamers/Escariadores/Alesatori/Reibahlen <i>HSS-E cobalt - DIN 212 - 30 dimensions tol. 0/+0.004</i>	Page 5
COF700-8	Alésoirs/Reamers/Escariadores/Alesatori/Reibahlen <i>Carbure/Carbide/VHM/MD - 8 dimensions H7</i>	Page 6
COF740-30	Alésoirs/Reamers/Escariadores/Alesatori/Reibahlen <i>Carbure/Carbide/VHM/MD - 30 dimensions tol. 0/+0.004</i>	Page 7
COF702-8	Alésoirs/Reamers/Escariadores/Alesatori/Reibahlen <i>Carbure/Carbide/VHM/MD - DIN 212 - 8 dimensions H7</i>	Page 8
COF742-30	Alésoirs/Reamers/Escariadores/Alesatori/Reibahlen <i>Carbure/Carbide/VHM/MD - DIN 212 - 30 dimensions tol. 0/+0.004</i>	Page 9

FRAISES DOUBLE HELICE 30/33° ANTIVIBRATOIRES

Série courte - Bout droit - Z4 - 2 dents au centre - Revêtues

EN : Solid carbide short endmills - Square nose - Double helix 30/33° - 4 flutes - 2 flutes until the center - Coated

ES : Fresas rectas cortas MD integral - Doble hélice 30/33° - 4 labios - 2 labios al centro - Con recubrimiento

IT : Frese dritte corte MD integrale - Doppia elica 30/33° - 4 taglienti - 2 taglienti al centro - Rivestite

DE : VHM kurze Schafffräser - Doppelhelix 30/33° - 4 Schneiden - 2 Zähne zur Mitte - Beschichtet



COFECHO-5

5 dimensions

Ø 4-5-6-8-10

Avec revêtement

99.90€

0/-0.05



h6



Ø	d	L	l	Z
4	4	40	12	4
5	5	50	14	4
6	6	57	16	4
8	8	60	20	4
10	10	70	22	4



Revêtement pour aciers trempés et fontes, avec ou sans lubrification

EN : Coating for tempered steels and cast iron, with or without cooling

ES : Recubrimiento para aceros templados y fundición, con o sin refrigeración

IT : Rivestimento per acciai temprati e ghisa, con o sin lubrificazione

DE : Beschichtung für gehärtete Stähle und Gusseisen, mit oder ohne Kühlung

ALESOIRS MACHINE HSS-E DIN 212 H7

Forme B - Taille hélicoïdale pour trous débouchants

EN : HSS-E machine reamers DIN 212 - Left hand helix for through holes - H7

ES : Escariadores de máquina HSSE DIN 212 - Hélice a izquierda para agujeros pasantes - H7

IT : Alesatori a macchina HSSE DIN 212 - Spirale sinistra per fori passanti - H7

DE : HSS-E Maschinenreibahlen DIN 212 - Linksspiralgenutet für Durchgangsloch - H7



COF210-8

8 dimensions

Ø 2-3-4-5-6-8-10-12

TOLERANCE H7

215€

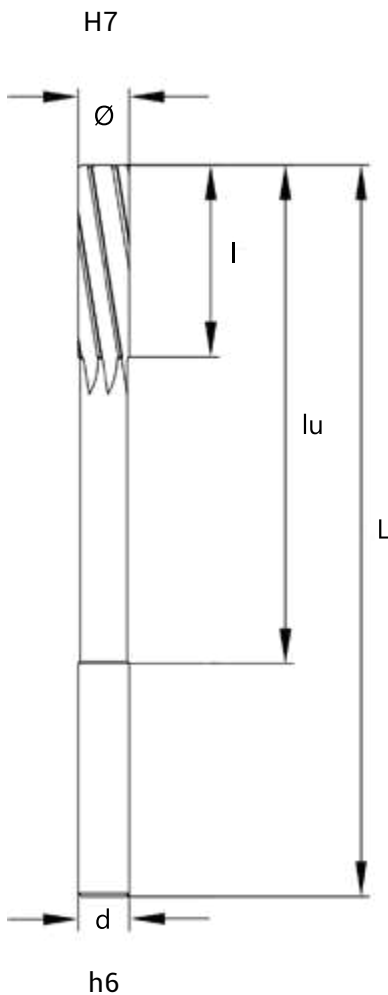

Ø	d	L	l	lu	Z
2	2	49	11	24	4
3	3	61	15	33	6
4	4	75	19	47	6
5	5	86	23	58	6
6	6	93	26	57	6
8	8	117	33	81	6
10	10	133	38	93	6
12	10	151	44	111	6

ALESOIRS MACHINE HSS-E DIN 212 PAR 1/100

Forme B - Taille hélicoïdale pour trous débouchants

EN : HSS-E machine reamers DIN 212 - Left hand helix for through holes

ES : Escariadores de máquina HSSE DIN 212 - Hélice a izquierda para agujeros pasantes

IT : Alesatori a macchina HSSE DIN 212 - Spirale sinistra per fori passanti

DE : HSS-E Maschinenreibahlen DIN 212 - Linksspiralgenutet für Durchgangsloch



885€

COF212-30

30 dimensions

- Ø 2.98-3.98-4.98-5.98-7.98-9.98
- 2.99-3.99-4.99-5.99-7.99-9.99
- 3.00-4.00-5.00-6.00-8.00-10.00
- 3.01-4.01-5.01-6.01-8.01-10.01
- 3.02-4.02-5.02-6.02-8.02-10.02

TOLERANCE 0/+0.004

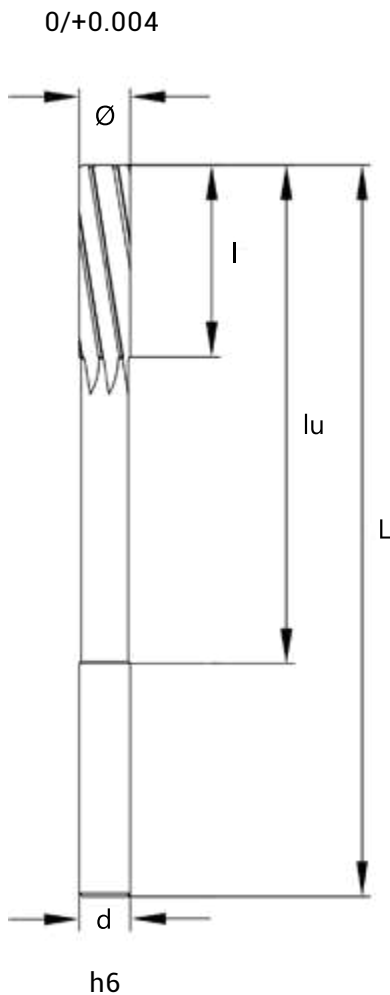

Ø	0.01 mm	d	L	I	lu	Z
2.98 → 3.00		3	61	15	33	6
3.01 & 3.02		4	65	16	37	6
3.98 → 4.02		4	75	19	47	6
4.98 → 5.02		5	86	23	58	6
5.98 → 6.00		6	93	26	57	6
6.01 & 6.02		6	101	28	65	6
7.98 → 8.02		8	117	33	81	6
9.98 → 10.02		10	133	38	93	6

ALESOIRS MACHINE TAILLE HELICOIDALE SERIE COURTE H7

Pour trous débouchants

EN : Solid carbide short machine reamers - Left hand helix for through holes

ES : Escariadores cortos MD integral - Hélice a izquierda para agujeros pasantes

IT : Alesatori corti MD integrale - Spirale sinistra per fori passanti

DE : VHM kurze Maschinenreibahlen - Linksspiralgenutet für Durchgangsloch



0/+0.004

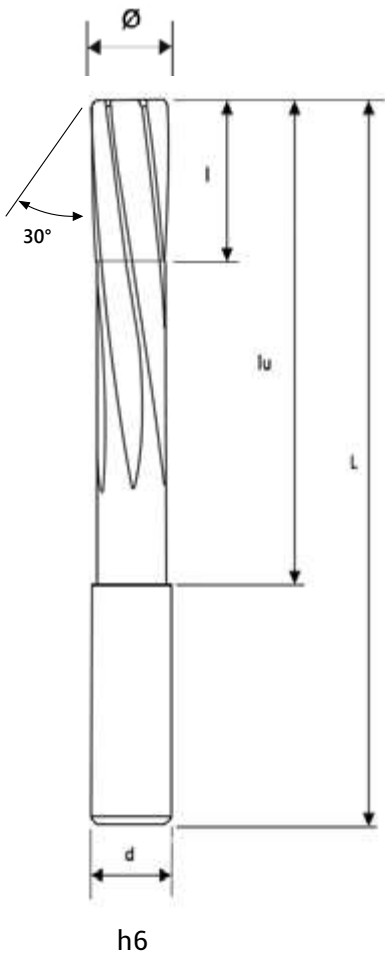

COF700-8

8 dimensions

\varnothing 2-3-4-5-6-8-10-12

TOLERANCE H7

510€



\varnothing	d	L	l	l_u	Z
2	2	49	10	30	3
3	3	61	12	36	4
4	4	75	12	47	4
5	5	86	16	56	4
6	6	86	16	56	4
8	8	86	16	56	6
10	10	90	20	60	6
12	12	95	20	60	6

ALESOIRS MACHINE TAILLE HELICOIDALE SERIE COURTE

Pour trous débouchants

EN : Solid carbide short machine reamers - Left hand helix for through holes

ES : Escariadores cortos MD integral - Hélice a izquierda para agujeros pasantes

IT : Alesatori corti MD integrale - Spirale sinistra per fori passanti

DE : VHM kurze Maschinenreibahlen - Linksspiralgenutet für Durchgangsloch



1960€

COF740-30

30 dimensions

Ø 2.98-3.98-4.98-5.98-7.98-9.98

2.99-3.99-4.99-5.99-7.99-9.99

3.00-4.00-5.00-6.00-8.00-10.00

3.01-4.01-5.01-6.01-8.01-10.01

3.02-4.02-5.02-6.02-8.02-10.02

TOLERANCE 0/+0.004

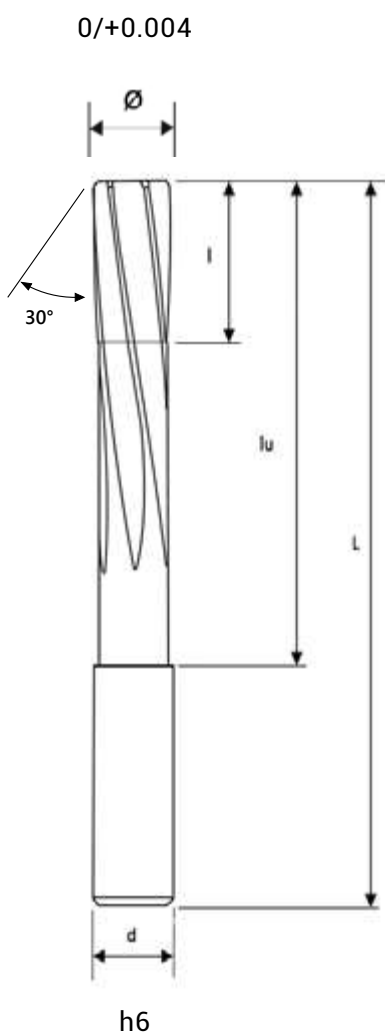

Ø	0.01 mm	d	L	l	lu	Z
2.98	→ 3.02	3	61	12	36	4
3.98	→ 4.02	4	75	12	47	4
4.98	→ 5.02	5	86	16	56	4
5.98	→ 6.02	6	86	16	56	4
7.98	→ 8.02	8	86	16	56	6
9.98	→ 10.02	10	90	20	60	6

ALESOIRS MACHINE TAILLE HELICOIDALE DIN 212 H7

Pour trous débouchants

EN : Solid carbide machine reamers DIN 212 - Left hand helix for through holes - H7

ES : Escariadores MD integral DIN 212 - Hélice a izquierda para agujeros pasantes - H7

IT : Alesatori MD integrale DIN 212 - Spirale sinistra per fori passanti - H7

DE : VHM Maschinenreibahlen DIN 212 - Linksspiralgenutet für Durchgangsloch - H7



0/+0.004

COF702-8

8 dimensions

Ø 2-3-4-5-6-8-10-12

TOLERANCE H7

630€

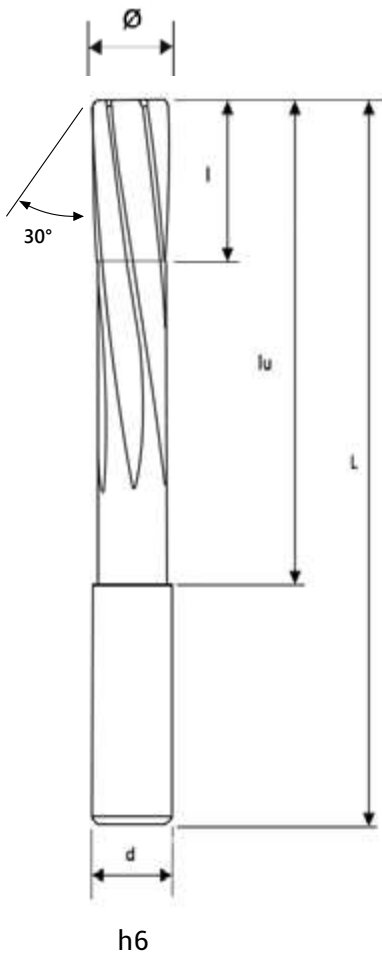

Ø	d	L	l	lu	Z
2	2	49	10	30	3
3	3	61	12	36	4
4	4	75	12	47	4
5	5	86	16	56	4
6	6	101	28	65	6
8	8	117	33	81	6
10	10	133	38	93	6
12	12	151	44	111	6

ALESOIRS MACHINE TAILLE HELICOIDALE DIN 212

Pour trous débouchants

EN : Solid carbide machine reamers DIN 212 - Left hand helix for through holes

ES : Escariadores MD integral DIN 212 - Hélice a izquierda para agujeros pasantes

IT : Alesatori MD integrale DIN 212 - Spirale sinistra per fori passanti

DE : VHM Maschinenreibahlen DIN 212 - Linksspiralgenutet für Durchgangsloch



2120€

COF742-30

30 dimensions

Ø 2.98-3.98-4.98-5.98-7.98-9.98

2.99-3.99-4.99-5.99-7.99-9.99

3.00-4.00-5.00-6.00-8.00-10.00

3.01-4.01-5.01-6.01-8.01-10.01

3.02-4.02-5.02-6.02-8.02-10.02

TOLERANCE 0/+0.004

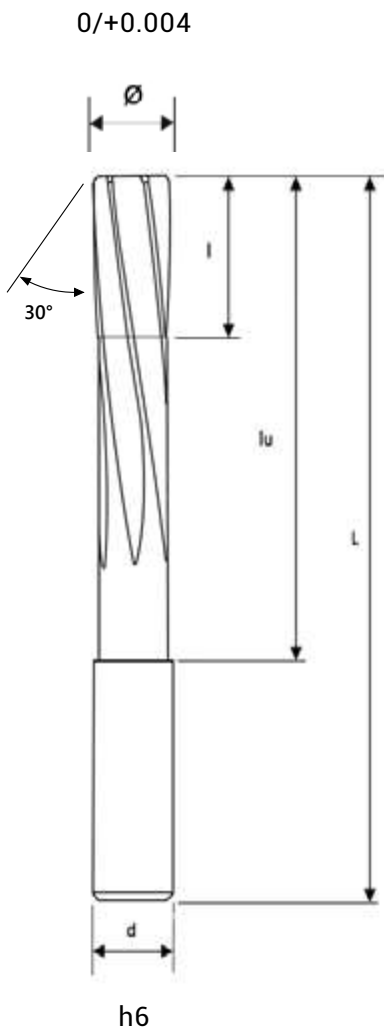

Ø	0.01 mm	d	L	l	lu	Z
2.98	→ 3.02	3	61	12	36	4
3.98	→ 4.02	4	75	12	47	4
4.98	→ 5.02	5	86	16	56	4
5.98	→ 6.02	6	101	28	65	6
7.98	→ 8.02	8	117	33	81	6
9.98	→ 10.02	10	133	38	93	6

EUROMAC

7 route de Sainte Montaine
Z. I. Les Pointards, 18410
Brinon-sur-Sauldre, France



TEL: +33 (0) 2 48 81 51 00
euromac@euromac.tools
euromac-cuttingtools.com

Distributeur



Cliquez sur les images pour voir nos autres catalogues

